



# **New NAVIGATOR**

## **Operator's Manual**

67020803 (10/04)

HARDI® reserves the right to make changes in design, material, or specification without notice thereof. HARDI® and other product names are registered trademarks of HARDI® Inc. in the U.S. and in other countries.

# Table of Contents

<b>Introduction</b> .....	<b>4</b>	<b>Adding Chemicals</b> .....	<b>21</b>
<b>Description</b> .....	<b>5</b>	Filling through the tank lid .....	21
Frame .....	5	Filling with the HARDI® chemical filler (optional) .	21
Adjustable wheel spacing.....	5	Operating with Liquid-based chemicals .....	21
Suspension (optional) .....	5	Operating with Powder-based chemicals .....	22
Tank .....	5	<b>Use of flush tank and rinse nozzles (optional) .....</b>	<b>23</b>
Pump.....	5	Technical residue .....	23
HARDI® SMART VALVE MANIFOLD system.....	5	Draining tanks .....	23
ECP operating unit.....	5	<b>Nozzle Selection</b> .....	<b>24</b>
ECPC operating unit .....	5	<b>Calibration</b> .....	<b>26</b>
Filters (standard and optional) .....	5	<b>Maintenance - rules of thumb</b> .....	<b>27</b>
Booms .....	5	Cleaning the sprayer .....	27
<b>Safety Instructions</b> .....	<b>6</b>	Guidelines .....	27
Operating the sprayer safely .....	6	Cleaning the tank .....	28
Handling chemical products safely.....	7	Cleaning and maintenance of filters.....	28
Local poison information center .....	7	<b>Lubrication</b> .....	<b>29</b>
<b>Connection</b> .....	<b>8</b>	About lubricants .....	29
Support jack .....	8	Recommended lubricants .....	29
Bottom step (optional).....	8	Lubrication schedule .....	30
<b>P.T.O. Shaft</b> .....	<b>9</b>	<b>Service and Maintenance Intervals</b> .....	<b>33</b>
P.T.O. shaft operator safety .....	9	10 hours service.....	33
Installation of P.T.O. shaft .....	9	50 hours service.....	34
<b>Wheel Spacing Adjustment</b>		250 hours service.....	34
<b>(Suspended and Non-suspended axle) .....</b>	<b>10</b>	1000 hours service.....	35
<b>Axle Clearance Adjustment</b>		Occasional maintenance.....	35
<b>(Suspended and Non-suspended axle) .....</b>	<b>10</b>	Pump valves and diaphragms replacement	
<b>Tires</b> .....	<b>11</b>	(363/463 pumps) .....	35
<b>Hydraulic System</b> .....	<b>11</b>	Pump valves and diaphragms replacement	
Connection requirements.....	11	(1302 pumps) .....	36
Hydraulics - standard joystick handle.....	12	Cone check/replacement ECP/ECPC	
Direct Acting Hydraulic system (D.H.).....	12	operating unit .....	37
Connecting electric controls.....	13	Cone check/replacement ECP/ECPC	
Disconnecting sprayer.....	13	distribution valve.....	37
Before operating sprayer .....	13	Wear bushing replacement, boom lift.....	37
<b>Transport</b> .....	<b>13</b>	Shock absorbers .....	37
Roadworthiness .....	13	Level indicator adjustment.....	38
Rear lights.....	13	Cord replacement, level indicator.....	38
Transport bracket settings .....	14	Nozzle tubes and fittings .....	38
Adjusting boom transport position.....	14	<b>Off-Season Storage</b> .....	<b>39</b>
<b>ECP Plumbing Diagram</b> .....	<b>15</b>	Preparation after off season storage.....	39
<b>ECPC Plumbing Diagram</b> .....	<b>16</b>	<b>Equipment and Accessories</b> .....	<b>40</b>
<b>Operation</b> .....	<b>17</b>	<b>Troubleshooting</b> .....	<b>43</b>
Operation of spraying functions .....	17	<b>Emergency Operation of the Sprayer</b> .....	<b>48</b>
Filling tanks with water .....	17	<b>Technical Specifications</b> .....	<b>49</b>
Tank capacities .....	17	Overall measurements .....	49
Filling through tank lids .....	17	Weight .....	49
<b>Quick Fill (optional)</b> .....	<b>18</b>	Filters and nozzles .....	50
General Quick Filling guidelines.....	18	Temperature and pressure ranges .....	50
<b>ECP &amp; ECPC Operating Unit</b> .....	<b>19</b>	Electrical connections - Rear lights.....	50
Controls adjustment.....	19	Electrical connections for ECP/ECPC	
Adjustment of constant pressure .....	19	operating unit .....	50
Operating the control unit while spraying .....	19	EAGLE™ boom hydraulics SPB-HZ and SPC-HZ .	51
Emergency operation .....	20	EAGLE™ boom hydraulics SPB-HY and SPC-HY .	51
Remote 4" pressure gauge (optional) .....	20	DH Hydraulics .....	52
Filters .....	20	<b>Warranty Policy and Conditions</b> .....	<b>53</b>
Self cleaning filter (ECP only) .....	20	<b>Notes</b> .....	<b>55</b>



Dear Owner,

Thank you for purchasing a HARDI® product and welcome to the ever- increasing family of HARDI® sprayer owners.

Our sprayers and accessories are rapidly becoming a familiar sight on North American farms. We believe that this results from growers becoming increasingly conscious of crop protection input costs and the vital need for cost effective spray application equipment.

Please take the time to thoroughly read the Operator's Manual before using your equipment. You will find many helpful hints as well as important safety and operation information.

Some of the features on your HARDI® New NAVIGATOR sprayer were suggested by growers. There is no substitute for "on farm" experience and we invite your comments and suggestions. If any portion of this instruction book remains unclear after reading it, contact your HARDI® dealer or service personnel for further explanation before using the equipment.

**For Product, Service or Warranty Information:**

- Please contact your local HARDI® dealer.

**To contact HARDI® directly:**

- Please use the HARDI® Customer Service number: 1-866-770-7063

- Or send your email to [CUSTSERV@hardi-us.com](mailto:CUSTSERV@hardi-us.com)

**HARDI® INC.**

**Visit us online at: [www.hardi-us.com](http://www.hardi-us.com)**

**HARDI® MIDWEST**

1500 West 76th St.

Davenport, Iowa 52806

Phone: (563) 386-1730

Fax: (563) 386-1710

**HARDI® GREAT LAKES**

290 Sovereign Rd.

London, Ontario N6M 1B3

Phone: (519) 659-2771

Fax: (519) 659-2821

**HARDI® WEST COAST**

8550 W. Roosevelt Avenue

Visalia, California 93291

Phone: (559) 651-4016

Fax: (559) 651-4160

Sincerely,

A handwritten signature in black ink, appearing to read "Tom L. Kinzenbaw".

Tom L. Kinzenbaw  
President

# Introduction

We congratulate you for choosing a HARDI® plant protection product. The reliability and efficiency of this product depends upon your care. The first step is to carefully read and pay attention to this instruction book. It contains essential information for the efficient use and long life of this quality product.

The New Navigator 1100 trailer sprayer consists of a powder coated frame with a tank, diaphragm or centrifugal pump, ECP control (Electric Control Plus) for diaphragm pump system or ECPC control (Electric Control Plus Centrifugal) for centrifugal pump system, HARDI® Smart Valve Manifold system, Self-Cleaning Filter (diaphragm only), Paralift™ Boom Lift System, and a 45', 50', 60', or 66' EAGLE™ SPB series spray boom. The 1100 trailer sprayers also offer an 80', 88', 90', or 100' EAGLE™ SPC series spray boom.



**New NAVIGATOR 1100 gallon with 100' Eagle™ SPC (HZ) boom**

# Description



## Description

### Frame

The frame is all steel construction. It has a strong chemical and weather resistant powder coat. Screws, nuts, etc. have been electrochemically treated to be resistant to corrosion.

### Adjustable wheel spacing

Allows infinite wheel spacing adjustment of 60" to 120".



**WARNING!** Use extreme caution with narrower wheel spacing (close to 60"). Always slow down before entering a curve, especially when turning on uneven ground or on a hillside.

**Note:** The wider the wheel spacing, the better the stability of the sprayer and boom.

### Suspension (optional)

Suspended axle systems are available featuring swing arms, dual coil springs and gas shock absorbers.

### Tank

The tanks, made of impact proof and chemical resistant polyethylene, have a purposeful design with rounded contours which allows for efficient cleaning and draining. The tanks are designed with a large deep sump, so that they can be completely emptied even when the sprayer is used on slopes up to 15% inclination. A remote operated drain valve is fitted for efficient draining. Available tank size - 1100 gallon.

### Pump

The HARDI® diaphragm pumps have low maintenance requirements and guaranteed pump life. The bearings and crankshaft are grease lubricated and are therefore protected from spray solution if any diaphragm fails in service. A drain hole is in the base of the crank case to facilitate the draining of any foreign matter. The diaphragm pumps are self priming and can be run dry without damage. Centrifugal pumps and plumbing systems are also available.

### HARDI® SMART VALVE MANIFOLD system

All functions of the spray circuit are selected via the centrally located simple, logical and functional MANIFOLD valves, featuring color coding and clear symbols for easy operation.

### ECP operating unit

The ECP operating unit consists of: control box, adjustable pressure agitation, pressure filter, HARDIMATIC mechanical rate controller (within same gear), 2-1/2" pressure gauge and individual boom feed valve featuring constant pressure device for unchanged application rate even if one or more boom sections are shut off. The master on/off switch on the control box operates by shutting off all boom sections regardless of whether individual boom switches are on or off.

### ECPC operating unit

The ECPC operating unit consists of: control box, adjustable pressure agitation, 2-1/2" pressure gauge and individual boom feed valves featuring constant pressure device for unchanged application rate even if one or more boom sections are shut off. The master on/off switch on the control box operates by shutting off all boom sections regardless of whether individual boom switches are on or off.

### Filters (standard and optional)

With the self-cleaning filter (ECP only), the impurities that exist in the spray liquid will pass the filter and be re-circulated back to the tank via the return flow. When the tank is emptied, the impurities are then flushed out through the drain. In-line filters and nozzle filters are standard to ensure the sprayer will have minimal nozzle blockages. Suction filter and filling filter are optional.

### Booms

The HARDI® New NAVIGATOR boom options are as follows:

#### New NAVIGATOR 1100

- 45', 50', 60', 66' Eagle™ SPB booms
- 80', 88', 90', 100' Eagle™ SPC booms

All of the booms are suspended in a strong, stable parallelogram boom lift - Paralift™.

Booms feature trapeze/pendulum suspension and an integrated spring suspension system with shock absorber dampening.

Please refer to the *EAGLE™ BOOM Operator's Manual* for more information.

# Safety Instructions

## SAFETY INFORMATION

### WARNING



**ALWAYS READ OPERATOR'S MANUAL BEFORE USING EQUIPMENT**

**DO NOT REMOVE ANY SAFETY DEVICES OR SHIELDS. NEVER SERVICE, CLEAN OR REPAIR A MACHINE WHILE IT IS OPERATING**

### WARNING



**ALWAYS WATCH FOR THIS SYMBOL TO POINT OUT IMPORTANT SAFETY PRECAUTIONS**

**IT MEANS ATTENTION! BECOME ALERT! YOUR SAFETY IS INVOLVED!**

## RECOGNIZE SAFETY INFORMATION



**This is the Safety-alert symbol. When you see this symbol on your machine or in this manual, be alert to the potential for personal injury.**

**Follow recommended precautions and safe operating practices.**

### Follow safety instructions

- Carefully read all the safety messages in this manual and the safety labels fitted to the machine. Keep safety labels in good condition. Replace missing or damaged safety labels. Be sure that new equipment components include any current safety labels. Replacement safety labels are available from your authorized HARDI® dealer.
- Learn how to operate the sprayer and how to use the controls properly. Do not let anyone operate the machine without proper instructions.

- Keep your sprayer in proper working condition. Unauthorized modifications or use may impair the function and/or safety and affect the machine's life.
- If you do not understand any part of this manual and need assistance, please contact your authorized HARDI® dealer.

### Operating the sprayer safely

1. Read the complete manual carefully and become familiar with the operation of the equipment before initial operation in each spraying season. Failure to do so may result in possible over or under application of spray solution which may drastically affect crop production and lead to personal injury.
2. Before starting the engine on the tractor unit, be sure all operating controls are in the off or neutral position, including (but not limited to) the P.T.O. shaft and/or spray controls. Be sure the tractor power train is disengaged.
3. Operate spray and boom functions only when seated in the operator's seat.
4. One of the most frequent causes of personal injury or death results from persons falling off or being run over. Do not permit others to ride on or in. Only one person should be working the machine when in operation.
5. Before leaving the tractor seat, stop the engine, put all controls in neutral, and put the transmission control lever in the park position or neutral with the brakes locked. Read the tractor operation manual for added safety precautions.
6. P.T.O. driven equipment can cause serious injury. Before working on or near the P.T.O. shaft, servicing or cleaning the equipment, put P.T.O. lever in the DISENGAGE position and stop the engine.
7. Do not fold or unfold boom near overhead wires. Serious injury or death could result if contact is made with electric wires.
8. Keep hands, feet & clothing away from moving parts.
9. Wear relatively tight and belted clothing to prevent from being caught on some part of the machine.
10. Slow down when turning, especially with boom unfolded.
11. Always keep children away from your sprayer and/or tractor unit.

# Safety Instructions

12. Before transporting the sprayer, ensure that the boom is fully folded and fully locked into transport position. Ensure all locking devices are fully engaged, whether hydraulic or mechanical.
13. Slow moving tractors and spray equipment can create a hazard when on public roads. Avoid personal injury or death resulting from any accidents by using flashing lights. Local regulations may require installation of flashing warning lights.
14. Avoid injuries from high pressure fluids penetrating the skin by relieving system pressure before disconnecting hydraulics or other lines. Ensure all fittings are tight before applying pressure to the system.
15. Understand service procedures before undertaking any maintenance. Never lubricate, service, or adjust the machine while it's moving. Securely support any components before working on them.
16. Keep all parts in good condition and properly installed. Fix damaged parts immediately. Replace worn or broken parts. Remove excessive buildup of grease, oil or debris.
5. Decontaminate equipment used in mixing, transferring and applying chemicals after use. Follow the instructions on the chemical label for the correct procedure required. Wash spray residue from outside of the sprayer to prevent corrosion.
6. Extreme care should be taken in measuring spray products. Powders should be used in suitable sized packages or weighed accurately. Liquids should be poured into a suitable graduated container. Keep chemical containers low when pouring. Wear a filtered respirator and let the wind blow away from you to avoid dust and/or splashes contacting the skin or hair.
7. Store chemicals in a separate, plainly marked locked building. Keep the chemical in its original container with the label intact.
8. Dispose all empty containers after rinsing in accordance with local regulations & by-laws. Dispose of all unused chemicals and left over fertilizer in an approved manner.
9. Keep a first aid kit and fire extinguisher available at all times when handling chemicals.

## Handling chemical products safely

1. Direct exposure to hazardous chemicals can cause serious injury. These chemicals can include lubricants, coolants, paints, adhesives and agricultural chemicals. Material Safety Data Sheets (M.S.D.S.) are available for all hazardous chemicals which inform the user of specific details including: physical and health hazards, safety procedures, and emergency response techniques.
2. Protective clothing such as rubber gloves, goggles, coveralls and respirator must be worn while handling chemicals. All protective clothing should be kept in excellent condition and cleaned regularly or discarded.
3. If chemicals come in contact with any exposed skin areas, wash immediately with clean water and detergent. Never place nozzle tips or any other components that have been exposed to chemicals to lips to blow out obstructions. Use a soft brush to clean spray nozzles.
4. Dedicate an area to fill, flush, calibrate and decontaminate sprayer where chemicals will not drift or run off to contaminate people, animals, vegetation, water supply, etc. Locate this area where there is no chance of children coming in contact with this residue.

## Local poison information center

If you live anywhere in the United States, the following toll free number will connect you to your Local Poison Information Center.

**PHONE NO. 1 - 8 0 0 - 2 2 2 - 1 2 2 2**

If you live outside the United States, find the number for the poison control center in your phone book and write it in the space below:

**PHONE NO.** \_\_\_\_\_ - \_\_\_\_\_ - \_\_\_\_\_

Keep a list, in the space provided below, of all the chemicals that you have in use.

1. \_\_\_\_\_
2. \_\_\_\_\_
3. \_\_\_\_\_
4. \_\_\_\_\_
5. \_\_\_\_\_
6. \_\_\_\_\_
7. \_\_\_\_\_
8. \_\_\_\_\_
9. \_\_\_\_\_
10. \_\_\_\_\_

# Sprayer Setup

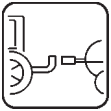

## Connection

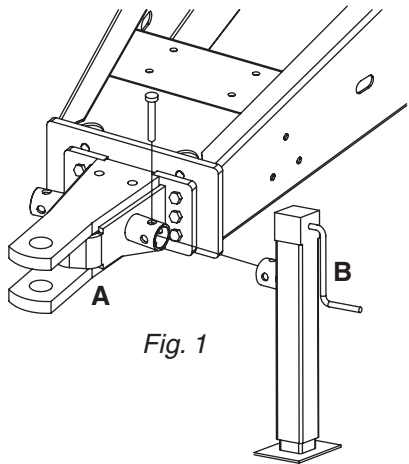

Fig. 1

Connect the sprayer to the tractor, adjusting the hitch mounting height (A Fig. 1) on the drawbar so that the sprayer is level.



**WARNING!** The drawbar bolts must be re-tightened to the specified torque every 8 hours of work until the torque is stabilized, and then at intervals stated in the service scheme (p. 34).



**WARNING!** Ensure the drawbar is secured to the tractor and cannot be accidentally disconnected. Safety chains are recommended when towing the sprayer.



**WARNING!** Your tractor will have decreased braking efficiency with the sprayer connected, particularly when the tank is full.

## Support jack

To remove support jack (B Fig. 1): lift leg, remove securing pin and pull out support jack. When sprayer is attached to the tractor, support jack is stored in a bracket on the left side of the frame (Fig. 2).

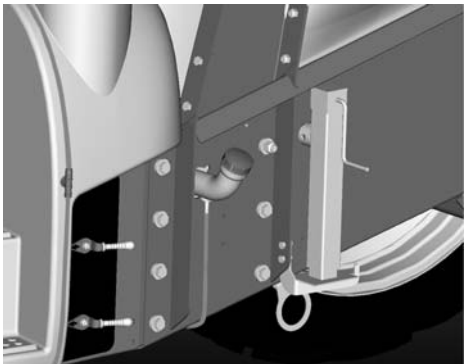

Fig. 2



**WARNING!** The support jack is not designed for lifting a full sprayer or supporting the trailer for extended periods if the sprayer is full of water.

## Bottom step (optional)

To access the front platform, pull the step lock pin out and lower the step (Fig. 3). Always lift up and push the step in to the locked position before driving. The step will lock automatically when it is lifted up.



LOCK PIN



LOCK PIN

Fig. 3



**WARNING!** Ensure the molded steps on the Flush Tank are kept clear of mud and debris to optimize their slip-resistant properties.



**WARNING!** Always ensure the Flush Tank tie-down strap is secured before moving sprayer or climbing onto steps (Fig. 4).

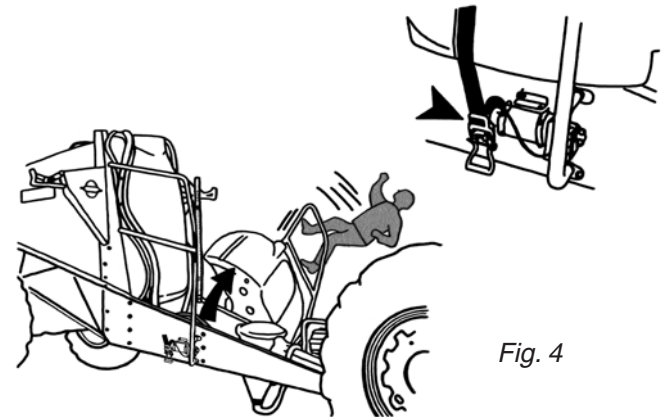

Fig. 4



Tie-down strap in secured position.



# Sprayer setup

## P.T.O. shaft operator safety



**WARNING: ALWAYS STOP ENGINE BEFORE ATTACHING THE TRANSMISSION SHAFT TO TRACTOR P.T.O. MOST TRACTOR P.T.O. SHAFTS CAN BE ROTATED BY HAND TO FACILITATE SPLINE ALIGNMENT WHEN ENGINE IS STOPPED.**

When attaching the shaft, make sure that the snap lock is FULLY ENGAGED - push and pull shaft until it locks.



**WARNING: ROTATING TRANSMISSION SHAFTS WITHOUT PROTECTION GUARDS ARE FATAL.**

Always keep protection guards and chains intact and make sure that the guards cover all rotating parts, including CV-joints at each end of the shaft. Do not use without protection guard.

Do not touch or stand on the transmission shaft when it is rotating - safety distance: min 5' (1.5 meters). Prevent protection guards from rotating by attaching the chains, allowing sufficient slack for turns.

Make sure that protection guards around the tractor P.T.O. and implement shaft are intact. Always STOP ENGINE and remove the ignition key before carrying out maintenance or repairs to the transmission shaft or implement.

## Installation of P.T.O. shaft



**WARNING: THE P.T.O. SHAFT ANGLE WILL CHANGE WHEN RAISING AND LOWERING THE CLEVIS. TO PREVENT EXCESSIVE LOADING AND BINDING ON THE P.T.O. SHAFT, IT MAY BE ADVISABLE TO LEAVE THE P.T.O. SHAFT DISCONNECTED UNTIL THE CLEVIS ADJUSTMENT IS COMPLETED. THEN THE P.T.O. SHAFT ADJUSTMENTS CAN BE MADE.**

Initial installation of the shaft is done as follows:

1. Attach sprayer to tractor and set sprayer in the position with shortest distance between the tractor and sprayer pump P.T.O. shafts.
2. Stop engine and remove ignition key.
3. If P.T.O. shaft must be shortened, the shaft is pulled apart. Fit the two shaft parts at tractor and sprayer pump and measure how much it is necessary to shorten the shaft. Mark the protection guards.

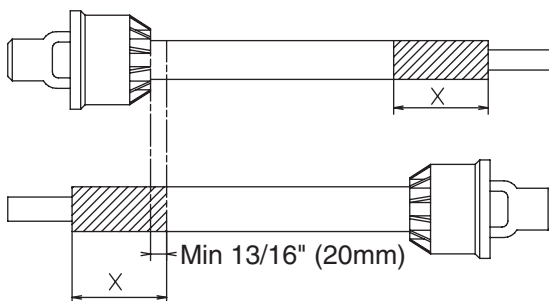

**Note:** The minimum allowable overlap for the shaft depends on the pump model.

### Pump with 6 splines (540 r.p.m.)

The shaft must always have a minimum overlap of 1/3 the length.

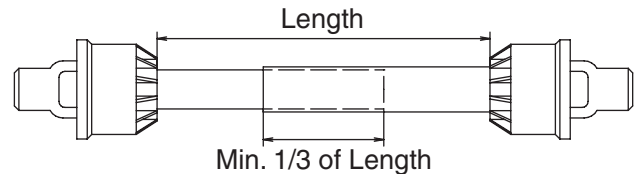

### Pump with 21 splines (1000 r.p.m.)

The shaft must always have a minimum overlap of 2/3 the length.

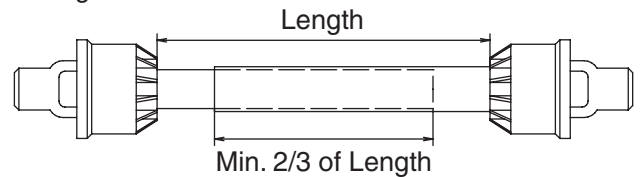

4. The two parts are shortened equally. Use a saw, and file the profiles afterwards to remove burrs.

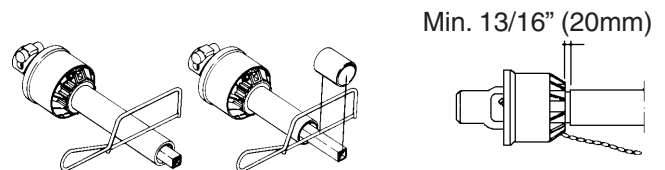

5. Grease the profiles, and assemble male and female parts again.
6. Fit the shaft to tractor and sprayer pump.

**Note:** Female part towards tractor. Fit chains to prevent the protection guards from rotating with the shaft.

7. To ensure long life of the P.T.O. shaft, try to avoid working angles greater than 15°.

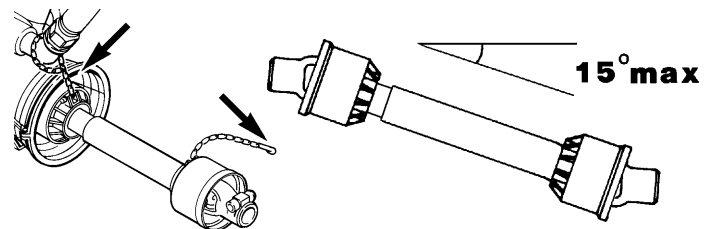

# Sprayer Setup

## Wheel Spacing Adjustment (Suspended and Non-suspended Axle)

Wheel spacing can be infinitely adjusted from 60" to 120" with suspended or non-suspended axle systems.

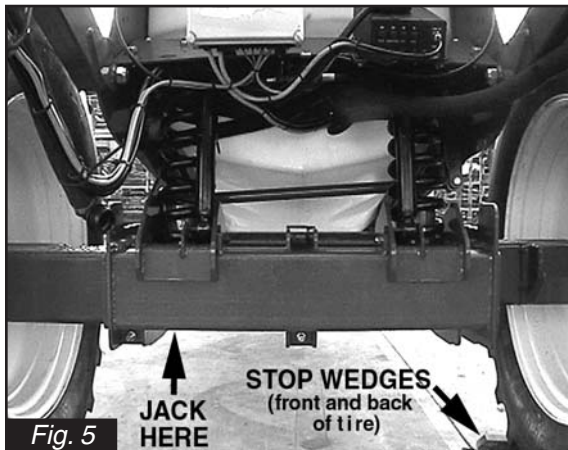
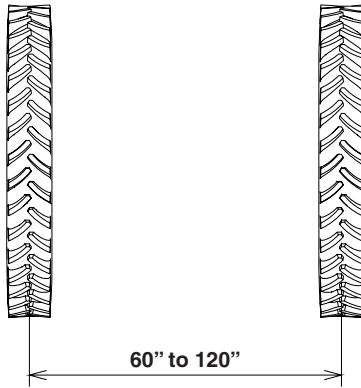

- 1 Measure the correct wheel spacing (Center of right hand tire to center of left hand tire). Each side must be extended or retracted half the desired alteration.
- 2 Attach sprayer to the tractor and engage tractor parking brake.
- 3 Place stop wedges in front of and behind the right hand wheel (Fig 5). Using suitable heavy duty equipment, jack up the left hand wheel. Ensure secure support for the sprayer body.
- 4 To release axle wedge for the left hand wheel axle and extend or retract the axle:  
Turn Nut (C Fig 6) counterclockwise to allow approx. 1" clearance. With an open-ended wrench, turn Nut (D Fig 6) against anchor plate until hold on axle is released. Shift axle to measured position.
- 5 To tighten axle wedge and secure axle at required width:  
Turn Nut (D Fig 6) counterclockwise to allow movement of stop wedge. Turn Nut (C Fig 6) clockwise against anchor plate to draw stop wedge up against the axle and hold it in position. Tighten to torque of 100 Ft/lb (135 Nm), then lock by re-tightening Nut (D Fig 6).

- 6 If the wheels were reversed and exchanged, remember to tighten the wheel nuts to the specified torque - rim plate to hub 120 Ft./lb (180 Nm).
- 7 Repeat the procedure on the right hand wheel.
- 8 Check the distance from the center of the tire to the center of the tank, to make sure the distance is equal from left to right.
- 9 Re-tighten the clamp bolts and wheel nuts to the specified torque after 8 hours of work.

**IMPORTANT!** Always place a jack under axle and lift the wheel to remove the load from the clamps before tightening the clamp bolts.

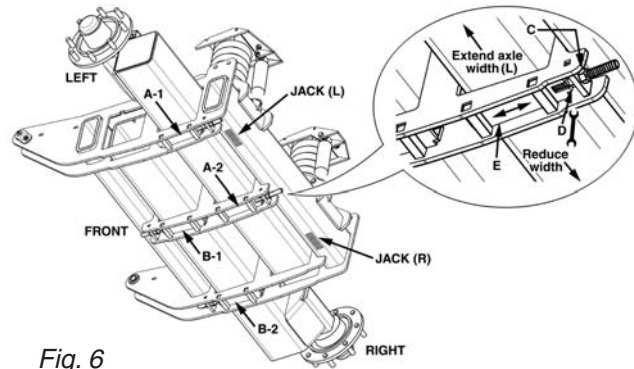

Fig. 6



**WARNING!** Use extreme caution with narrower wheel spacing (close to 60"). Always slow down before entering a curve, especially when turning on uneven ground or on a hillside.

**Note:** The wider the wheel spacing, the better the stability of the sprayer and boom.

## Axle Clearance Adjustment (Suspended and Non-suspended Axle)

The two axle inserts are equipped with offset spindles allowing for a "low" or "high" clearance setting. To change axle clearance:

- 1 Follow steps 1-4 in "Wheel spacing adjustment" section to release left axle insert.
- 2 Slide axle insert completely out and rotate 90°.

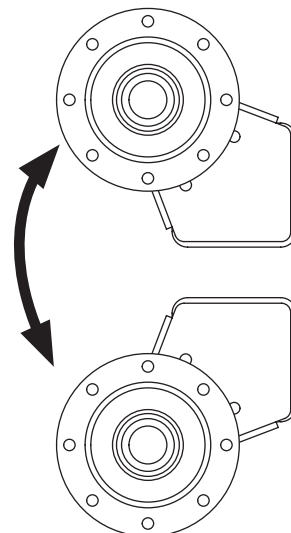

# Sprayer Setup

**Note:** Make sure the left axle offset faces the front of the sprayer and the right axle offset faces the rear of the sprayer so the axles are aligned.

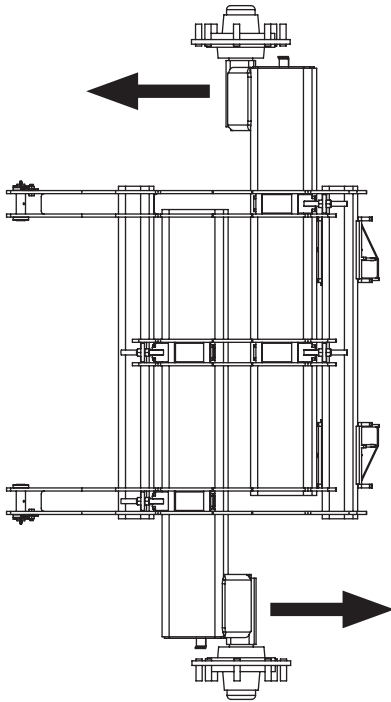

**BOTTOM VIEW**

- 3 Re-insert axle insert and follow steps 5-9 in "Wheel spacing adjustment" section to tighten.
- 4 Repeat procedure for right axle insert.

## Tires

Equal pressure in both tires is essential. Pressure should be kept as low as practical. For recommended pressures see *Tire pressures* (p. 34).



**WARNING!** Never inflate tires above the specified pressures. Over-inflated tires can explode and cause severe personal injuries.

**Note:** Sprayers fitted with rate controllers/monitors must always maintain the same tire pressure as when calibrated.

## Hydraulic System

### Connection requirements

Connection requirements for *EAGLE™* booms are:

- One single acting outlet for the lift function of the spray boom.
- One double acting outlet for the folding and/or tilt function of the spray boom.

**Note:** The hydraulic system requires an oil capacity of approximately 0.8 GPM (3 liters) and a minimum pressure of 1,950 PSI (130 bar).



**BE SURE TO HOOK UP HYDRAULIC LINES PROPERLY!**

**ENSURE HYDRAULIC LINES HAVE NOT BEEN DAMAGED DURING SHIPPING.**

**ESCAPING HYDRAULIC FLUID UNDER PRESSURE CAN PENETRATE THE SKIN CAUSING SERIOUS INJURY. AVOID THIS HAZARD BY RELIEVING PRESSURE BEFORE DISCONNECTING HYDRAULIC LINES.**

**ENSURE ALL CONNECTIONS ARE TIGHT BEFORE APPLYING PRESSURE, SEARCH FOR LEAKS WITH A PIECE OF CARDBOARD NOT YOUR HANDS!**

**IMPROPER HOOK-UP CAN CAUSE DANGEROUS BOOM MOVEMENTS AND/OR DAMAGE TO THE SPRAYER HYDRAULICS.**

**DO NOT ALLOW ANYONE NEAR A HYDRAULIC BOOM IN OPERATION.**

**ALWAYS SHUT TRACTOR OFF WHEN CONNECTING, SERVICING OR ADJUSTING BOOM.**

Make sure that the hydraulic couplers are clean before connecting to the tractor's remote outlets.

**IMPORTANT!** Due to the variation in tractor hydraulic systems and capacities, care should be exercised when initially operating the sprayer hydraulic cylinders. It is advisable to adjust the hydraulic flow control down to the minimum rate before operating the system. Adjust/increase the flow control after the system is bled of any air, if necessary.

# Sprayer Setup

## Hydraulics - standard joystick handle

### Installation of handle

1. Attach the control handle/joystick (A Fig 9) to the hydraulic lever that operates the double acting outlet to be used. The universal mounting bracket (B Fig 9) is very flexible and a number of different mounting positions can be used.
2. Connect the plug (C Fig 9) to the tractor's 12V power system. Try to hook-up the handle as close as possible to the battery power supply. HARDI® recommends using an electric distribution box (ref. no. 817925) to ensure a good power supply to various 12V attachments.

**Note:** Check with your dealer or tractor operator's manual for the best location to hook up the 12V system.

### Note polarity:

BROWN wire = Positive (+)  
BLUE wire = Negative (-)

3. Connect electric plug (D Fig 9) from sprayer's hydraulics to plug (E Fig 9) on handle.

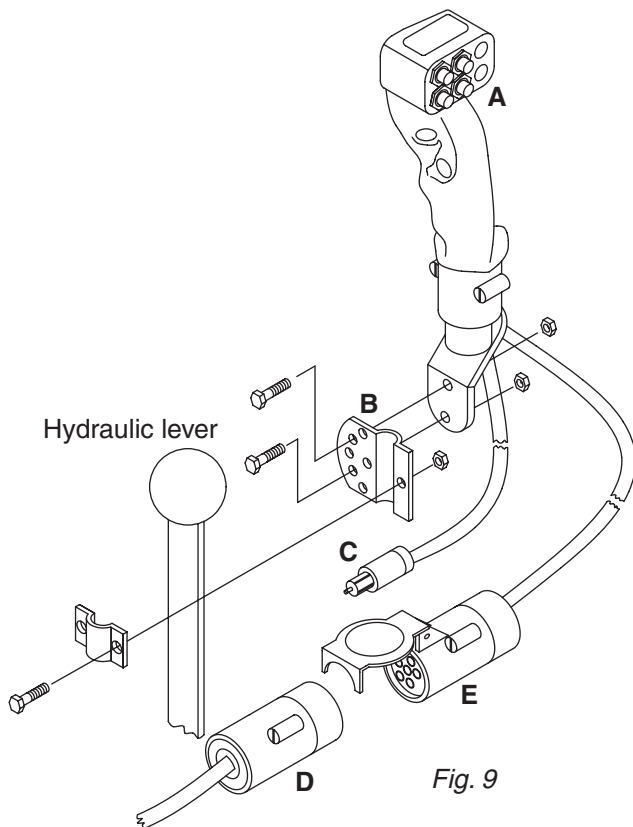

## Direct Acting Hydraulic system (D.H.)

### Installation of control box

1. Connect the plug (A Fig 10) to the tractor's 12V power system. Try to hook up the handle as close as possible to the battery power supply. HARDI® recommends using an electric distribution box (ref. no. 817925) to ensure a good power supply to various 12V attachments.

**Note:** Check with your dealer or tractor operator's manual for the best location to hook up the 12V system.

**Note polarity:** BROWN wire = Positive (+)  
BLUE wire = Negative (-)

2. Route the cable, with the 7 pins, from the hydraulic mount plate to the tractor.
3. Mount the hydraulic control box (B Fig 10) in a suitable location in the tractor cabin.
4. Connect the female 7 pin plug (C Fig 10) from the switch box to the 7 pin male plug (D Fig 10) from the sprayer.

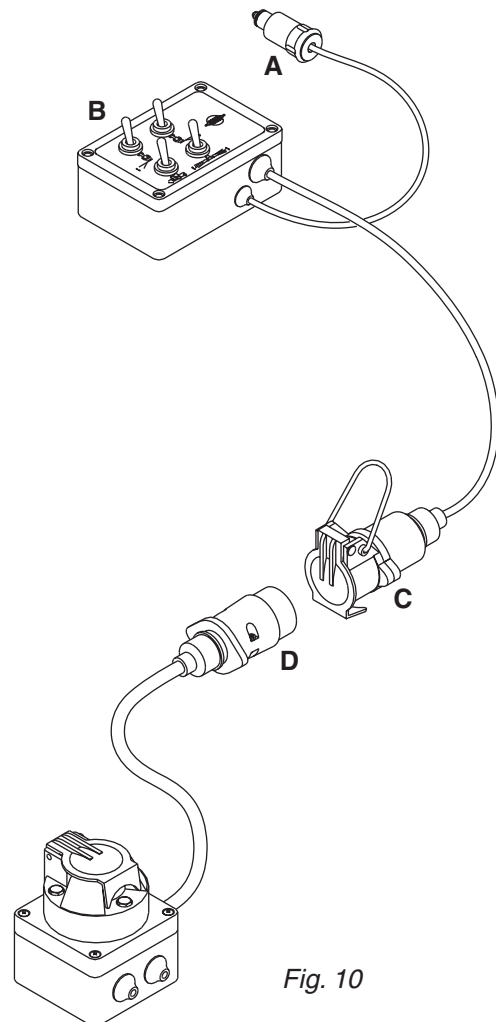

# Sprayer Setup

## Connecting electric controls

The control box for ECP or ECPC controls should be mounted at a convenient place in the tractor cab. The control box has 4 screw holes in the back cover which need to be drilled out for mounting on a flat surface (using the mount plate, bracket and hardware furnished with the sprayer).

There should be a minimum of 8 amp fuse protecting this circuit. Power requirement is 12 volt DC.

### Note polarity:

Brown pos. (+)

Blue neg. (-)

The wires must have a cross-sectional area of at least 12wg (4mm<sup>2</sup>) to ensure sufficient power supply. The boxes must be fused according to the following table. Use the optional HARDI® Electric 12 volt outlet box (#817925 - Fig 11) if more than one power outlet is needed.



Fig. 11

## Disconnecting sprayer

Always clean the sprayer inside and outside before disconnecting and parking it. See *Cleaning* (pp. 28-29).

Before disconnecting the sprayer from the tractor, make sure the support jack is properly fitted.



**WARNING!** To prevent the sprayer from tipping over, do not disconnect the sprayer from the tractor with the boom unfolded, unless the boom is securely supported.

Place stop wedges in front of and behind wheels. Remember to disconnect all hoses and cables from the tractor.



**WARNING!** If the sprayer is parked unattended, avoid unauthorized persons, children and animals having access to the sprayer.

## Before operating sprayer

Although the sprayer has had a strong and protective surface treatment applied to steel parts, bolts, etc. in the factories, it is recommended to apply a thin layer of anti-corrosion oil to all metal parts, hoses and tires.

There are many factors that affect the selection of protective oils, such as temperature and humidity, and exposure to UV, salt and chemicals. Your local distributor of oil products will be able to advise on the best specific formula for you local conditions. If this is done before the sprayer is put into operation for the first time, it will always be easy to clean the sprayer, avoid chemicals discoloring the protective coating, and keep the coatings shiny for many years.

This treatment should be carried out every time the protective film is washed off.

## Transport Roadworthiness

Slow moving tractors and spray equipment can create a hazard when on public roads. Make sure the S.M.V. sign is in place and clearly visible from the rear of the sprayer (Fig 12).

**NOTE!** Max. driving speed is 15 mph (25 km/h).

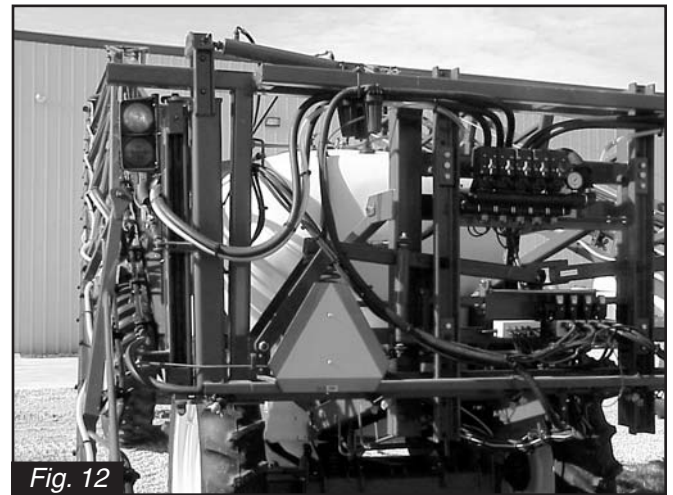

Fig. 12

## Rear lights

Local regulations may require the use of flashing warning lights. Connect plug for rear lights to the tractor's 7-pin socket, and check function of rear lights, stop lights and direction indicators on both sides before driving.

# Sprayer Setup

## Transport bracket settings

The transport brackets on the New Navigator for the Eagle™ SPB and SPC booms are installed at the factory and have no adjustment.

The rear transport lock is adjustable, but is set at the factory according to the boom installed on the sprayer. This should not need adjustment unless a different boom is installed on the sprayer.



**WARNING!** Always measure the actual total height of your sprayer to be sure that there is plenty of clearance at all times while transporting the sprayer.

## Adjusting boom transport position

If the boom wings do not rest accurately in the transport brackets, the hydraulic fold cylinders can be adjusted so the wings stop at the right position above the transport brackets (*Fig 13*).



*Fig. 13*  
Eagle™ Transport bracket

The cylinders can be adjusted as described below:

1. Lift the boom all the way to the top.
2. Fold the boom into transport position. With the fold cylinder pressurized, determine if the boom wings need to be adjusted inwards or outwards.
3. Relieve the pressure from the fold cylinder by unfolding the boom a few inches.

If the boom rests too far in on the transport brackets, loosen the nut (**B** *Fig 14*) and adjust collar (**A** *Fig 14*) in towards the cylinder housing.

If the boom rests too far out on the transport brackets, the collar (**A** *Fig 14*) has to go out from the cylinder housing.

4. Secure jam nut (**B** *Fig 14*).
5. Pressurize the cylinder to see if the boom is properly adjusted. If not, repeat the above procedure until it is correctly adjusted.

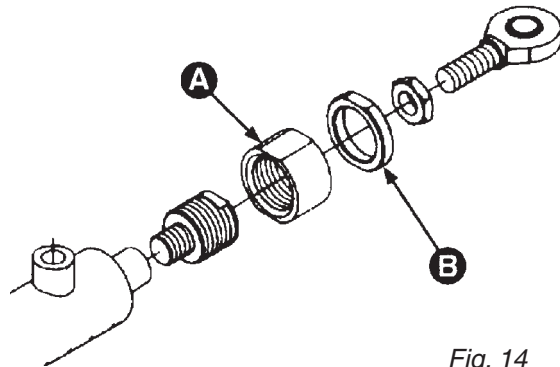
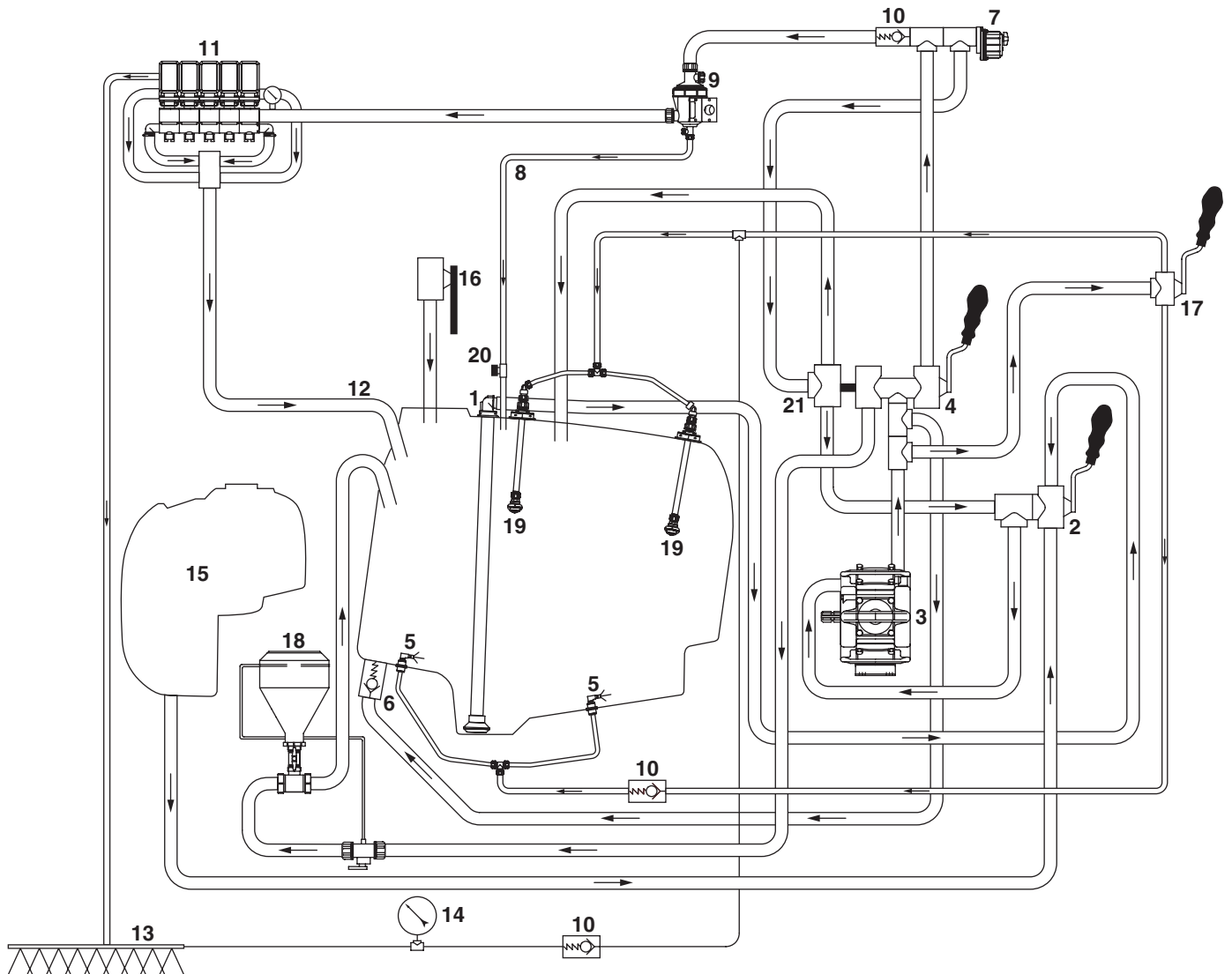

*Fig. 14*

# Operation

The HARDI® New NAVIGATOR trailer sprayer is available with either diaphragm or centrifugal plumbing systems. Take time to review and study the plumbing diagram for your sprayer. By following the flow through the diagram, you will better understand the various functions of your sprayer system.

## ECP PLUMBING DIAGRAM (for diaphragm pump systems)



- |                                       |                                   |
|---------------------------------------|-----------------------------------|
| 1. Suction filter                     | 12. Pressure equalization return  |
| 2. Suction manifold                   | 13. Boom                          |
| 3. Pump                               | 14. Boom pressure gauge           |
| 4. Pressure manifold                  | 15. Flush tank                    |
| 5. Agitation                          | 16. Quick fill                    |
| 6. Safety valve                       | 17. Variable Agitation manifold   |
| 7. HARDI-MATIC                        | 18. HARDI® chemical inductor      |
| 8. Return line (Self-cleaning filter) | 19. Tank rinse nozzles            |
| 9. Self-cleaning filter               | 20. Self-cleaning filter shut-off |
| 10. Check valves                      | 21. Return by-pass                |
| 11. Boom section valves               |                                   |

# Operation

The HARDI® New NAVIGATOR trailer sprayer is available with either diaphragm or centrifugal plumbing systems. Take time to review and study the plumbing diagram for your sprayer. By following the flow through the diagram, you will better understand the various functions of your sprayer system.

## ECPC PLUMBING DIAGRAM (for centrifugal pump systems)

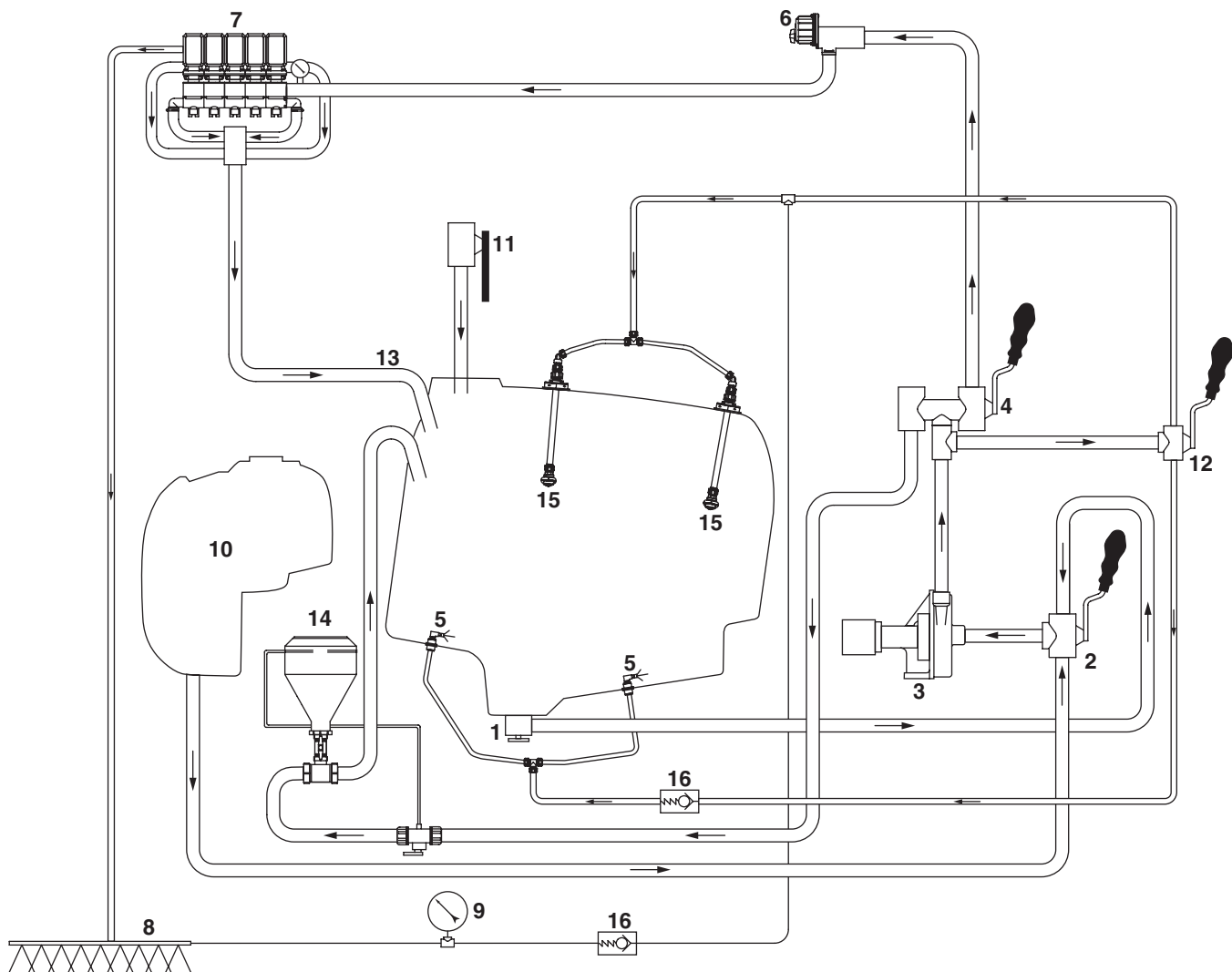

1. Bottom Suction Valve
2. Suction manifold
3. Pump
4. Pressure manifold
5. Agitation
6. HARDI-MATIC
7. Boom section valves
8. Boom

9. Boom pressure gauge
10. Flush tank
11. Quick fill
12. Variable Agitation manifold
13. Pressure equalization return
14. HARDI® chemical inductor
15. Tank rinse nozzles
16. Check valves



# Operation



## Operation

The HARDI® SMART VALVE system is located on the left hand side of the sprayer. This 3-part plumbing control system permits easy operation of the HARDI® NAVIGATOR sprayer.

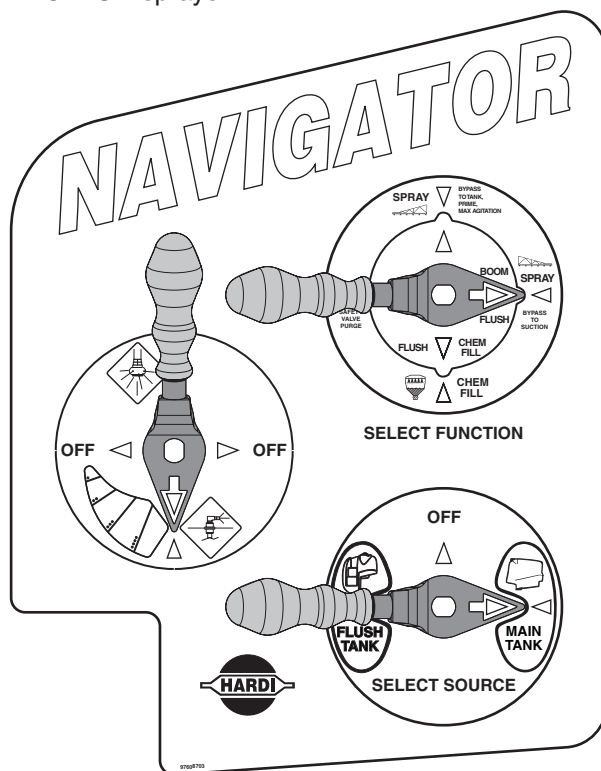

### Operation of spraying functions:

- Use the SELECT FUNCTION handle (upper right) to select the desired function. Note that function icons shown within the Green outer ring (e.g. SPRAY MAX AGITATION), indicates the source of fluid is the Main Tank. Function icons within the Blue inner ring indicate fluid supplied from the Flush Tank (optional system).
- Use the SELECT SOURCE handle (lower right) to select the correct source of the water and/or chemical solution. Note the color coding: Green for main tank and Blue for flush tank (optional system).
- Use the Variable Agitation handle (left) to control the amount of flow through the agitation nozzles. It also operates the Rinse nozzles (optional).

**IMPORTANT!** Always ensure the indicator arrows on the handles are carefully aligned with the corresponding arrows on the decal. Misalignment may result in incorrect fluid movement.

**NOTE!** All fluid system options are shown in this manual. If your sprayer is not equipped with all options, some of the selections shown may not be possible on your sprayer without adding additional equipment (e.g. HARDI® Chemical filler).

### Filling tanks with water



**WARNING!** Do not overfill any tank as this may cause chemical spillage out of the tank.

### Tank capacities

	(U.S. Gallons)	(Liters)
Main Tank	1100	4000
Foam Marker Tank	20 or 40	75 or 150
Flush Tank	130 (Nav 1100)	500 (Nav 5000)
Clean Water Tank	4	15

Water can be filled into the tanks in the following ways:

- 1 Filled through tank lids (All tanks).
- 2 Filled by external water supply through the quick fill system (main tank only).

The main tank should normally be filled with 25% of the required spraying water before adding the chemicals.

**IMPORTANT!** Always read the instructions on the chemical container.

**IMPORTANT!** The clean water handwash tank is filled separately to ensure that there is no risk of chemical solution moving from the valve system into handwash water.

**IMPORTANT!** It is recommended to use water as clean as possible for spraying purposes.

### Filling through tank lids Handwash (clean water) tank

Screw open the clean water tank lid and fill with clean water only.

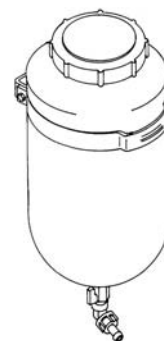

**IMPORTANT!** The water from this tank is only for hand washing, cleaning blocked nozzles, etc.



**WARNING!** Although the Handwash tank is only filled with clean water, the water must never be used for drinking, due to the small risk of contamination while filling, etc.

# Operation

## Flush tank (optional system)

Screw open the flush tank lid and fill with water.



## Foam marker tank (optional)

The fill inlet for the foam marker tank is found to the right of the Hardi® Navigator Smart Valve Control Panel as shown in (Fig 15).



Fig. 15

## Main tank

Screw open the main tank lid and fill with water through the strainer to prevent rust or other particles entering the tank.

An overhead tank will allow high filling capacity.



**WARNING!** Do not let the filling hose etc., enter any tank. Keep it outside the tank, pointing towards the filling hole. If the end of the hose is beneath the surface of the tank contents, and the water pump at the water supply plant stops, chemicals could be siphoned back and contaminate water supply lines.

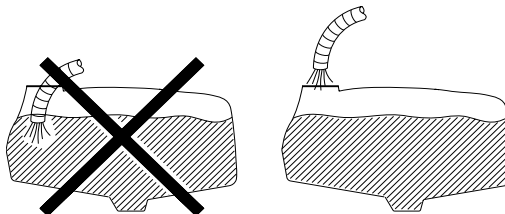

## Quick Fill (Optional)

The optional QUICK FILL allows the operator to connect a hose from a water supply (i.e. overhead fill tank), and fill the main tank.



**WARNING!** Do not fill tank so rapidly that air cannot escape - tank may rupture.

## General Quick Filling guidelines

- 1 Remove the camlock plug from the front of the quick fill valve (Fig 16).



Fig. 16

- 2 Connect the filling hose from the water supply.
- 3 Open the quick fill valve and fill tank to desired level.
- 4 Close the quick fill valve and remove filling hose.
- 5 Remember to re-fit the camlock plug to the quick fill coupler when filling is complete.

# Operation

## ECP/ECPC Remote control box

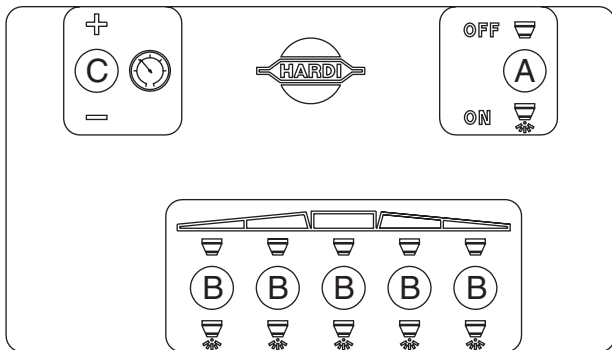

Fig 17

- A. Master ON/OFF switch for distribution valves.
- B. Individual ON/OFF switches for distribution valves.
- C. Pressure regulating switch

## ECP Operating unit (ECPC similar)

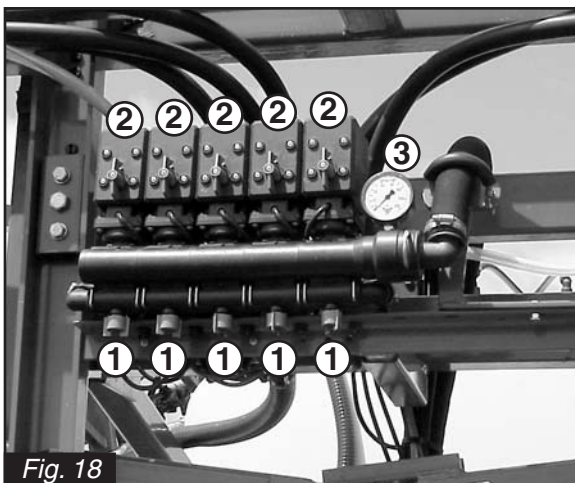

Fig. 18

## Pressure control valve

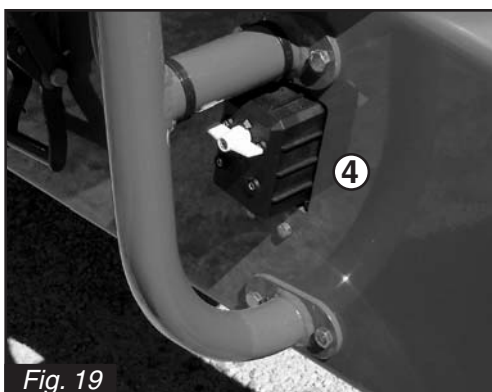

Fig. 19

- 1. Adjustment screw for constant boom pressure
- 2. Distribution valves
- 3. System pressure gauge
- 4. Pressure control valve

## ECP & ECPC OPERATING UNIT

### Controls adjustment

Before spraying, adjust the ECP or ECPC operating unit using clean water (without chemicals).

1. Choose the correct nozzle (pp. 24-25). Make sure that all nozzles are the same type and capacity.
2. Put the tractor in neutral and adjust the P.T.O. r.p.m. until the number of revolutions of the pump corresponds to the intended traveling speed. Remember the number of revolutions on the P.T.O. must be kept between 300-600 r.p.m. (540 r.p.m. pump) or 650-1100 (1000 r.p.m. pump) to ensure correct operation of the HARDI-MATIC system.
3. On-off switch (A Fig 17) is "ON" against green symbol (down position).
4. All distribution valve switches (B Fig 17) are also "ON" against green symbol (down position).
5. Hold pressure regulating switch (C Fig 17) down (-) until handle on pressure control valve (4 Fig 19) stops rotating. This will be the "minimum pressure" setting.
6. Hold pressure regulating switch (C Fig 17) up (+) until desired pressure is shown on the boom pressure gauge.

### Adjustment of constant pressure

**Note:** Adjust the constant distribution boom pressure one section at a time as follows: (Start with the valve turned closed before adjusting).

1. Shut-off the first boom distribution valve switch (B Fig 17).
2. Turn the adjusting screw (1 Fig 18) until the pressure gauge again shows the same pressure as in step 6 (above). (Turn the screw clockwise for higher pressure, counterclockwise for lower pressure).
3. Turn the first boom distribution valve switch (B Fig 17) back on.
4. Repeat steps 1 through 3 for the remaining boom section valves.

**Note:** Hereafter, adjustment of the constant boom pressure will only be needed if you change to nozzles with other capacities, but not required if only changing pressure or application rate using the same nozzles.

### Operating the control unit while spraying

In order to shut off the entire boom, flip on-off switch (A Fig 17) to the "OFF" (red) symbol (up position). This returns all the pump outputs to the main tank through the return system. The diaphragm anti-drip valves ensure instantaneous closing of all nozzles.

In order to shut off one or more sections of the boom, switch one or more unneeded boom section valves (B Fig 17) to off position. The constant pressure system ensures that the pressure does not increase in the sections which are still open.

# Operation

## Emergency operation

In case of electrical failure, it is still possible to manually override all functions of the operating unit. To operate manually, disconnect the multiplug from the ECP or ECPC control box first and operate the handles by hand. It is possible to change pressure and turn booms on or off.

**Note:** Since the ON/OFF switch normally operates by shutting off all boom distribution valves, you will need to manually shut off all distribution valves to shut off the complete control unit manually.

**IMPORTANT!** When the sprayer is stored, the ECP or ECPC control box and the multiplug must be protected against moisture and dirt. A plastic bag may be used to protect the multi plug. Store the control box in a clean dry place.

## Remote 4" pressure gauge (optional)

The remote pressure gauge is located on the front handrail (Fig 20). This gauge measures the working pressure in the boom tubes as close to the nozzles as possible. This pressure reading will always be slightly lower than the reading at the operating unit pressure gauge.

The outputs stated in the nozzle charts are always based on the pressures measured at the nozzle.

Always adjust pressure when calibrating and spraying according to readings at the Remote pressure gauge.

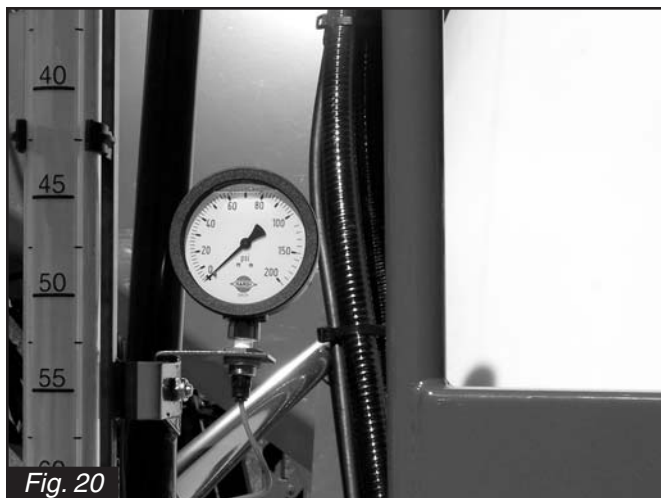

## Filters

Filters should always be used, and their function checked regularly. The mesh size of the filter should always be smaller than the flow average of the nozzles used. Therefore, pay attention to the correct combination of filters and mesh size. The recommended suction filter is 50 mesh - this allows good flow to the pump with little restriction. The standard self cleaning filter is 100 mesh.

Refer to the chart below for correct filter recommendations.

ISO Flat Spray Nozzle Size	Suction Filter	Self Cleaning Filter	In-Line Filter	Nozzle Filter
075-01-015-02	50	100	100	100
025-03	50	80	80	80 (50)
04 and larger	30	80 (50)	50	50

Suction filter screens do wear from dirt and chemical particles. If nozzle filters continually block with chemical particles, then use the next size coarse nozzle filter.

## Self cleaning filter (ECP only)

**IMPORTANT!** Note direction of restrictor in (Fig 21).

### Correct restrictor choice

It is important to have a large flow through the filter. This is achieved by choosing restrictor size in relation to the liquid consumption of the spray boom and pump output.

Four restrictors are supplied. Use the green one (largest orifice) first.

Disconnect the hose (Fig 21) at the self cleaning filter, place the restrictor in the hose and reconnect.

If the required working pressure cannot be obtained, the restrictor is too large. Choose a smaller one; Starting with black, then white and finally red.

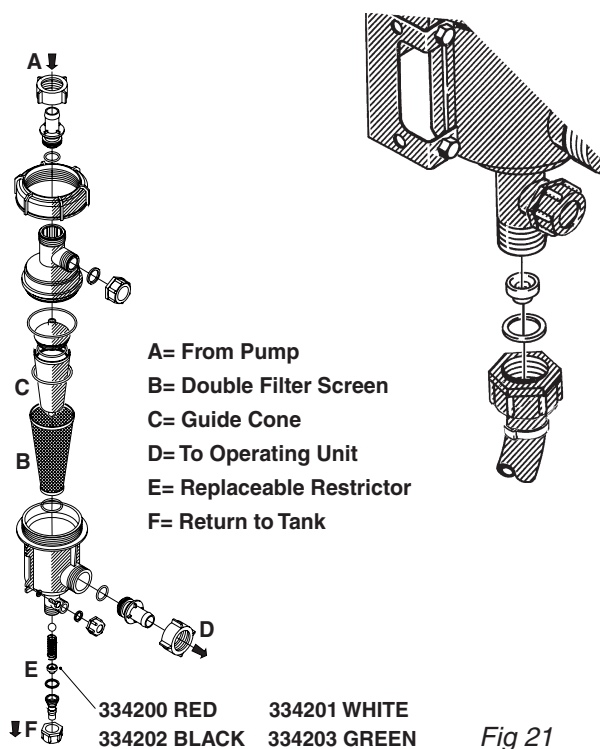

Fig 21

# Operation

## ADDING CHEMICALS

Chemicals can be filled into the tank two different ways:

1. Through the tank lid.
2. By using the HARDI® CHEMICAL FILLER device.



**WARNING!** Be careful not to slip or splash chemicals when carrying chemicals up to the tank lid.



**WARNING!** Always use the personal protection stated on the chemical container and as a minimum, always use gloves, face protection shield and coveralls.

## Filling through the tank lid

The chemicals are filled through the tank lid - Note instructions on the chemical container!

- 1 Fill the main tank with clean water, allowing space for the addition of chemicals. See *Filling tanks with water* (pp. 17-18).
- 2 Make sure the ECP operating unit main on/off switch is in the off position.
- 3 Turn the Select Source handle to MAIN TANK. Turn the Select Function handle to SPRAY MAX AGITATION, and turn the Variable Agitation handle straight down for maximum flow through the agitation nozzles (Fig 22).

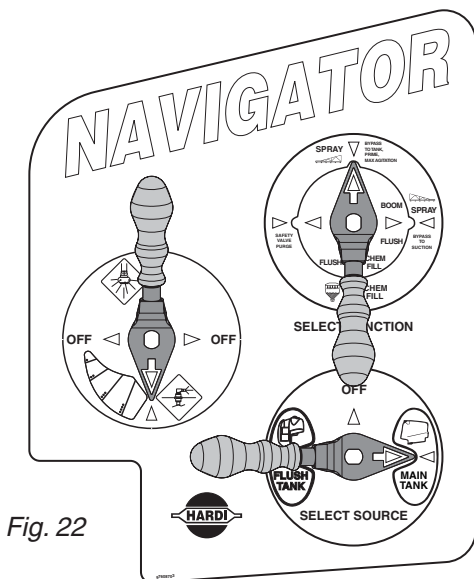

Fig. 22

- 4 Engage the pump and set P.T.O. revolutions to 540 r.p.m. or 1000 r.p.m. (depending on pump model).
- 5 Add the chemicals through the main tank hole.
- 6 When the spray liquid is well mixed, it may be sprayed on the crop. Leave the Select Function handle pointing to the SPRAY MAX AGITATION arrow and turn the Variable Agitation handle down so the spray liquid is continuously agitated while spraying (Fig 22).

## Filling with the HARDI® chemical filler (optional)

The HARDI® CHEMICAL FILLER is located directly in front of the flush tank / working platform.



Fig. 23

## Operating with Liquid-based chemicals

- 1 Make sure the ECP operating unit main on/off switch is in the off position.
- 2 Fill the flush tank with clean water and fill the main tank at least 1/3 with clean water (unless something else is stated on the chemical container label). See *Filling tanks with water* (pp. 17-18).
- 3 Turn the Select Source handle to MAIN TANK. Turn the Select Function handle to CHEM FILL and turn the Variable Agitation handle straight down for maximum flow through the agitation nozzles (Fig 24).

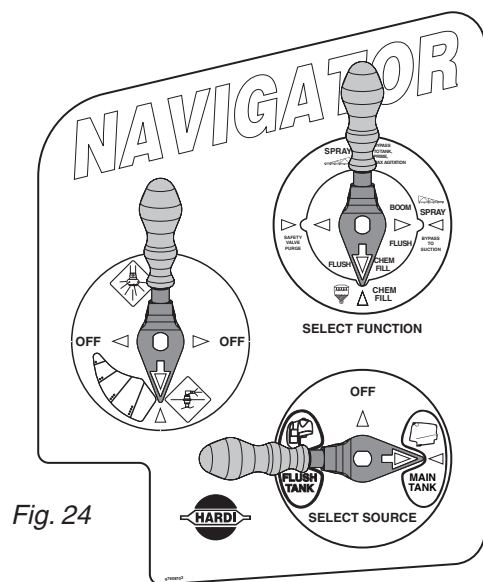

Fig. 24

# Operation

- 4 Make sure the bottom valve (**A** Fig 25) is closed on the HARDI® CHEMICAL FILLER.
- 5 Engage the pump and set P.T.O. revolutions to 540 r.p.m. or 1000 r.p.m. (depending on pump model).
- 6 Open the HARDI® CHEMICAL FILLER lid.
- 7 Measure the correct quantity of chemical and fill it into the hopper.

**Note:** The measuring scale in the hopper can only be used if the sprayer is parked on level ground. It is recommended to use a measuring jug for best accuracy.

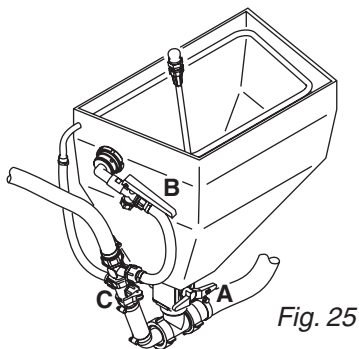

Fig. 25

- 8 Open the bottom valve (**A** Fig 25) to transfer the chemical to the main tank.
- 9 If the chemical container is empty, it can be rinsed by using the Bag & Bottle Rinse (optional). Place the container over the multi-hole nozzle and press the lever (**B** Fig 25).



**WARNING!** Do not press lever (**B** Fig 25) unless the multi-hole nozzle is covered by a container to avoid spray liquid hitting the operator.

**IMPORTANT!** If the Select Source handle is turned to MAIN TANK, the Bag & Bottle Rinse uses diluted spray solution from the main tank to rinse containers of concentrated chemicals. Always rinse the chemical containers with clean water several times until they are clean before disposal. Turn the Select Source handle to FLUSH TANK (optional) to use clean water to rinse the chemical containers.

- 10 Engage the hopper rinsing device by opening valve (**C** Fig 25).
- 12 Close valve (**C** Fig 25) again when the hopper is rinsed.

**IMPORTANT!** If the Select Source handle is turned to MAIN TANK, the hopper rinsing device uses diluted spray solution from the main tank to rinse the hopper of concentrated chemicals. Always rinse the hopper with clean water when finished spraying. Turn the Select Source handle to FLUSH TANK (optional) to use clean water to rinse the hopper.

- 13 Close valve (**A** Fig 25) and the chemical hopper lid. Turn the Select Function handle to SPRAY MAX AGITATION and turn the Variable Agitation handle down to mix the chemicals in the main tank. Leave the Smart Valves in this configuration so the spray liquid is continuously agitated while spraying.

## Operating with Powder-based chemicals

- 1 Make sure the ECP operating unit main on/off switch is in the off position.
- 2 Fill the flush tank with clean water and fill the main tank at least 1/2 with clean water (unless something else is stated on the chemical container label). See *Filling tanks with water* (pp. 17-18).
- 3 Turn the Select Source handle to MAIN TANK. Turn the Select Function handle to CHEM FILL and turn the Variable Agitation handle straight down for maximum flow through the agitation nozzles (Fig 26).

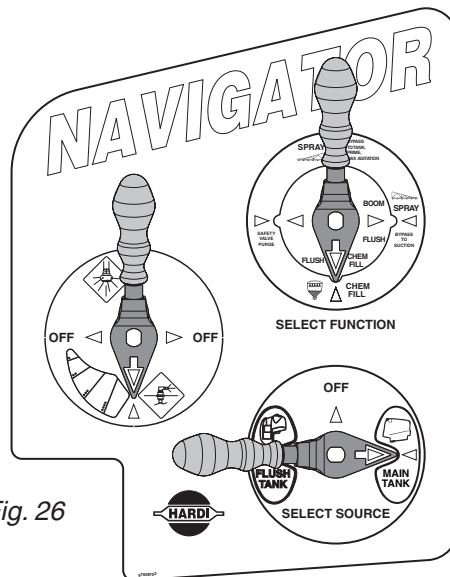

Fig. 26

- 4 Engage the pump and set P.T.O. revolutions to 540 r.p.m. or 1000 r.p.m. (depending on pump model).
- 5 Open the bottom valve (**A** Fig 27) on the HARDI® CHEMICAL FILLER and open the lid.

- 6 Engage the hopper rinsing device by opening valve (**C** Fig 27).
- 7 Measure the correct quantity of chemical and sprinkle it into the hopper as fast as the rinsing device can flush it down.

- 8 If the chemical container is empty, it can be rinsed by using the Bag & Bottle Rinse (optional). Fit the bag bracket and place the powder bag over the multi-hole nozzle and press the lever (**B** Fig 27).

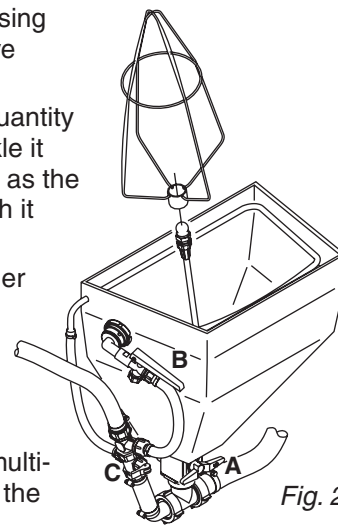

Fig. 27



**WARNING!** Do not press lever (**B** Fig 27) unless the multi-hole nozzle is covered by a container to avoid spray liquid hitting the operator.

# Operation

**IMPORTANT!** If the Select Source handle is turned to MAIN TANK, the Bag & Bottle Rinse uses diluted spray solution from the main tank to rinse containers of concentrated chemicals. Always rinse the chemical containers with clean water several times until they are clean before disposal. Turn the Select Source handle to FLUSH TANK (optional) to use clean water to rinse the chemical containers.

- 9 Close valve (C Fig 27) again when the hopper is rinsed.

**IMPORTANT!** If the Select Source handle is turned to MAIN TANK, the hopper rinsing device uses diluted spray solution from the main tank to rinse the hopper of concentrated chemicals. Always rinse the hopper with clean water when finished spraying. Turn the Select Source handle to FLUSH TANK (optional) to use clean water to rinse the hopper.

- 10 Close valve (A Fig 27) and the chemical hopper lid. Turn the Select Function handle to SPRAY MAX AGITATION to mix the chemicals in the main tank. When the spray liquid is well mixed, it may be sprayed on the crop. Leave the Select Function handle pointing to the SPRAY MAX AGITATION arrow and the Variable Agitation handle pointing down so the spray liquid is continuously agitated while spraying.

## Use of flush tank and rinse nozzles (optional)

The incorporated flush tank can be used for two different purposes.

**A.** In-field diluting of remaining spray liquid residue in the spraying circuit for spraying the liquid in the field, before cleaning the sprayer.

1. In order to empty the sprayer as much as possible, turn the Select Source handle turned to MAIN TANK, turn the Select Function handle to SPRAY BYPASS TO SUCTION and turn the Variable Agitation handle to OFF. Spray until air comes out of all nozzles.



**IMPORTANT!** If the sprayer is equipped with a centrifugal pump (ECPC), do not run pump dry for longer than 3 seconds. Otherwise severe damage to the pump will occur.

2. Remove the tank filter basket.
3. Turn the Select Source handle to FLUSH TANK and turn the Variable Agitation handle to TANK RINSE.
4. Engage and set the pump at approx. 300 r.p.m.
5. When rinsing water corresponding to approx. 10 times the spray liquid residue is used, turn Select Source handle to MAIN TANK and operate all valves, so all hoses and components are rinsed.
6. Turn the Variable Agitation handle to OFF, turn the Select Function handle to BYPASS TO SUCTION. Spray liquid in the field you have just sprayed.
7. Repeat steps 3-6 until the flush tank is empty.

**B.** Rinsing the pump, operating unit, spray lines, etc. in case of interruption in spraying before main tank is empty (e.g. due to rain, etc.).

1. Turn the Select Source handle to FLUSH TANK, turn the Select Function handle to BOOM FLUSH and turn the Variable Agitation handle to OFF.
2. Engage the pump and spray water from flush tank in the field until all nozzle tubes/nozzles are flushed with clean water.
3. Disengage pump and turn Select Source valve to the OFF position.



**WARNING!** The rinse nozzles cannot always guarantee a 100% cleaning of the tank. Always clean manually with a brush afterwards, especially if crops sensitive to the chemical just sprayed are going to be sprayed afterwards.

## Technical residue

Inevitably a quantity of spray liquid will remain in the system (which cannot be sprayed properly on the crop) as the pump takes in air when the tank is about to be empty. The technical residue is defined as the remaining liquid quantity in the system as the first clear pressure drop on the pressure gauge is read.

The dilutable residue must be diluted with 10 times the amount of clean water and sprayed onto the crop just sprayed before cleaning the sprayer - see *Cleaning* (pp. 27-28).

## Draining tanks

### Main tank drain valve

Pull the string at the left hand side of the tank to open the drain valve. The valve is spring-loaded to close it, but can be kept open by pulling the string out and upwards in the V-shaped slot (Fig 28).

To release and close the drain valve again, pull the string downwards and the valve will close automatically.

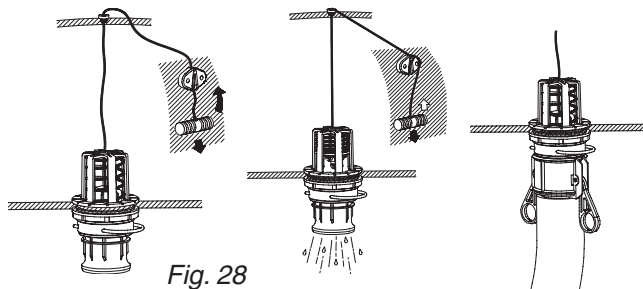
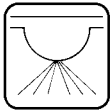

Fig. 28

If draining a residue (e.g. liquid fertilizer) into a container, a 2 1/2" snap-coupler with hose can rapidly be connected to the drain valve, and the liquid safely drained.

# Nozzle Selection



## Nozzle Selection

Correct selection of nozzle and calibration of the sprayer are critical to achieve accurate and cost effective use of farm crop protection products.

Your HARDI® sprayer has been supplied with 110° flat spray Red ISO Color Tips™ that will apply approximately 20 U.S. GPA at 30 PSI and 5 MPH.

The 110° flat spray nozzle was chosen rather than the 80 degree nozzle for two reasons: 1- It may be used at a lower minimum height which reduces the risk of wind drift; 2- it's greater overlap permits better uniformity of spray distribution, particularly if boom height varies on rough ground. Normal boom height setting with 110° nozzles is 18" to 20" above the crop or weeds, whichever is taller.

Should you wish a different application rate or different type of nozzle, HARDI® manufactures a nozzle for virtually every need.



**IMPORTANT: Always consult your chemical supplier for recommended chemical rate and water application rate. Always wear protective gloves when handling nozzles.**

The following tables show what types of spray nozzles are suitable for different applications. It is important to use the correct nozzle.

	<p>HARDI® ISO COLOR TIPS™ 110 degree flat fan, one piece cap and nozzle; color coded for flow rate selection. For herbicides, insecticides, and fertilizer applications. 50, 80, and 100 mesh screens are normally used.</p>	<p>F110</p>
	<p>HARDI® ISO LowDrift COLOR TIPS™ 110 degree flat fan, one piece cap and nozzle, 1553 solid stream nozzle; color coded for flow rate selection.</p>	<p>LD110</p>
	<p>HARDI® INJET™ Nozzles; air inclusion nozzles with removable restrictor. Color coded for flow rate selection. In-Line Filters will normally be used.</p>	
	<p>FLAT SPRAY NOZZLES in 65 degree, 80 degree, and 110 degree spray angles. For herbicides, insecticides, and fertilizer applications. 50, 80, and 100 mesh screens are normally used.</p>	<p>4665-65 degree 2080-80 degree 4110-110 degree  Part # 330013- O-ring</p>
	<p><b>FLOOD NOZZLES</b> set at 40" spacing. Designed for high volume application.</p>	<p>4598</p>



# Nozzle Selection

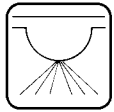

The following tables show what types of spray nozzles are suitable for different applications. It is important to use the correct nozzle.

	<p><b>HOLLOW CONE NOZZLES</b> for high pressure and high volume insecticide application in row crops. 1553 nozzles are ALWAYS used with swirl plates shown below EXCEPT when used as solid stream nozzles. 50,80, or 100 mesh screens are normally used with these nozzles.</p>	<p>1553 Must add swirl to produce hollow cone pattern</p>
	<p><b>SWIRL PLATE</b> used in conjunction with cone nozzle to create desired spray pattern. These swirls work with 1553 series cone nozzles. Grey, blue, or black swirls are used to create hollow cone effect. White swirls are used to create full cone effect.</p>	<p>Grey Blue Black White</p>
	<p><b>HOLLOW CONE CERAMIC NOZZLES</b> for high pressure and high volume fungicide and insecticide application.</p>	<p>1299</p>
	<p><b>LARGE DROPLET HOLLOW CONE NOZZLE</b> for use where drift must be kept to a minimum. These nozzles must always be fitted with 1553 nozzles and grey swirl plates. 50,80 or 100 mesh screens are normally used with these nozzles.</p>	<p>371077</p>
	<p><b>LARGE DROPLET FLAT SPRAY TIP IN 150 DEGREE SPRAY ANGLE.</b> Always used in conjunction with 1553-14-16-18 or 20 cone nozzle. 50,80 or 100 mesh screens are normally used with these nozzles.</p>	<p>371551</p>
	<p><b>SOLID STREAM NOZZLE</b> for high volume liquid fertilizer application. In this application, the 1553 nozzle is always used with 330013 o-ring and 50,80 or 100 mesh screens.</p>	<p>1553 less swirl</p>
	<p><b>HARDI® QUINTASTREAM - 5 HOLE LIQUID FERTILIZER NOZZLE</b> Five streams of liquid are distributed at different angles and flows. Highest flow is from the middle stream and lowest in the outer; overlapping streams. This allows for boom movements that do not influence distribution. Boom heights of 20" can be used as safely as 30".</p>	<p>372011 thru 372019</p>

# Calibration



## Calibration



**WARNING: ALWAYS CALIBRATE YOUR SPRAYER WITH CLEAN WATER ONLY! IN ADDITION, WEAR PROTECTIVE CLOTHING WHEN CALIBRATING YOUR SPRAYER!**

### Why must you calibrate a sprayer?

A nozzle selection chart will tell you what application rate you should expect. Variations due to nozzle wear, errors in pressure adjustment, and tractor speedometer can result in a possible error in application rate.

### How do you calibrate a sprayer?

Calibration kits are available from HARDI®, #818493 for US gallons & #818492 for metric calibration.

Following are some tips to remember when using the calibration kit method:

- When determining the length of time required to drive the recommended distance, drive in actual field conditions with a half-full tank.
- Repeat the test several times, each time avoiding the tracks from the previous test. Take the average of the times recorded.
- Calibration of the sprayer should be completed at the beginning of the season and repeated after every 2 to 3 full days of spraying, and every time you change volume rate or use new nozzles.
- Before you calibrate, check the flow of each nozzle. If it puts out more than 10% of its original volume, replace it.

Select your calibration method- Ounce method or Formula method.

Then follow the steps described below:

### Ounce Method

1. Determine how long it takes you to cover the test strip. Use the following chart to determine the length of your test strip. Row width for broadcast application is equal to your nozzle spacing. For your drop nozzle or band application, use row spacing.

Row width or nozzle spacing (in.)	Distance (ft.)
40	102
38	107
36	113
34	120
32	127
30	136
28	146
26	157
24	170

Row width or nozzle spacing (in.)	Distance (ft.)
22	185
20	204
18	227
16	255
14	291

2. Measure the amount of time it takes you to travel the test strip when throttle is set at spraying speed.
3. In a container (with oz. measurements), catch the spray from one nozzle for that amount of time. For drop or band nozzles, catch the spray from all nozzles for the row.
4. Read the ounces in the container. That is the actual U.S. GPA applied (ounces = GPA).

### Formula Method

1. Check your spraying speed. Measure a test strip of at least 200 feet (300 feet is ideal). Travel the distance at the speed you plan on spraying and record the time it takes to travel the distance. Read from the chart or use the formula to find your exact travel speed.

### Travel Time (in seconds)

Speed in MPH	200 ft.	300 ft.
3.0	45	68
3.5	39	58
4.0	34	51
4.5	30	45
5.0	27	41
6.0	23	34
7.0	19	29
7.5	18	27
8.0	17	26
9.0	15	23

### Formula:

$$\frac{\text{distance (ft.)} \times 0.68}{\text{seconds}} = \text{MPH}$$

2. Calculate the required nozzle output. Use either the nozzle wheel (if nozzle spacing is 20 inches), or this formula:

### Formula:

$$\text{GPM} = \frac{\text{GPA} \times \text{MPH} \times \text{W (in.)}}{5940}$$

### Formula:

$$\text{GPM} = \frac{10 \times 7 \times 20}{5940} = .24 \text{ GPM}$$

### Note:

- W=
- Nozzle spacing (in inches) for broadcast application.
  - Row spacing (in inches) divided by number of nozzles per row for drop nozzle application.
  - Sprayed band width or swath width (in inches) for band application divided by number of nozzles per band.
  - Note that on the nozzle wheel, W = 20 inches.

# Calibration / Maintenance



3. Set correct pressure. Read the required pressure from the nozzle table in the nozzle catalogue or nozzle wheel. With clean water in the tank and line, turn on the sprayer and set the target pressure. Collect the spray from one nozzle for one minute in a container. Adjust pressure until you collect the precise GPM called for.

## Calibration for carriers other than water

Use the following water rate conversion chart to determine the right conversion factor. When you've determined the new converted GPM or GPA, you can follow the steps on either the pressure or ounce method of calibration.

Weight of solution	Specific Gravity	Conversion Factors
7.00 lbs/gal.	0.84	0.92
8.00 lbs/gal.	0.96	0.98
8.34 lbs/gal-water	1.00	1.00
9.00 lbs/gal	1.08	1.04
10.00 lbs/gal	1.20	1.10
10.65 lbs/gal-28% N	1.28	1.13
11.00 lbs/gal	1.32	1.15
12.00 lbs/gal	1.44	1.20
14.00 lbs/gal	1.68	1.30

Example: 20 GPA of 28% N

Then GPA (solution) x conversion factor = GPA (water)

20 GPA (28% N) x 1.13 = 22.6 GPA (water)

Calibrate for 22.6 GPA of water

For conversion to Imperial gallons per acre,  
multiply U.S. GPA by .833

For conversion to liters per hectare,  
multiply U.S. GPA by 9.34

For conversion to liters per acre,  
multiply U.S. GPA by 3.78

Formula for tractor speed:  $\frac{\text{Distance (in feet)}}{\text{Second}} \times .682 = \text{MPH}$

## Maintenance - rules of thumb

In order to derive full benefit from the sprayer for many years, the following service and maintenance program should be followed.



**IMPORTANT!** Always read the individual paragraphs. Read instructions for service/maintenance jobs carefully before starting on the job. If any portion remains unclear or requires facilities which are not available, then for safety reasons please leave the job to your HARDI® dealer's workshop.

## Cleaning the sprayer

### Guidelines

1. Read the whole chemical label. Take note of any particular instructions regarding recommended protective clothing, deactivating agents, etc. Read the detergent and deactivating agent labels. If cleaning procedures are given, follow them closely.
2. Be familiar with local legislation regarding disposal of pesticides washings, mandatory decontamination methods, etc. Contact the appropriate department, e.g. Dept. of Agriculture.
3. Pesticide washings can usually be sprayed out on a soakaway. This is an area of ground that is not used for cropping. You must avoid seepage or runoff of residue into streams, water courses, ditches, wells, springs, etc. The washings from the cleaning area must not enter sewers. Drainage must lead to an approved soakaway.
4. Cleaning starts with the calibration, as a well calibrated sprayer will ensure the minimal amount of remaining spray liquid.
5. It is good practice to clean the sprayer immediately after use and thereby rendering the sprayer safe and ready for the next pesticide application. This also prolongs the life of the components.
6. It is sometimes necessary to leave spray liquid in the tank for short periods, e.g. overnight, or until the weather becomes suitable for spraying again. Unauthorized persons and animals must not have access to the sprayer under these circumstances.
7. If the product applied is corrosive, it is recommended to coat all metal parts of the sprayer before and after use with a suitable rust inhibitor.

### Remember:

**Clean sprayers are safe sprayers.  
Clean sprayers are ready for action.  
Clean sprayers cannot be damaged by pesticides and their solvents.**

# Maintenance

## Cleaning the tank

1. Dilute remaining spray liquid in the tank with at least 10 parts of water and spray the liquid out in the field you have just sprayed - See "Use of flush tank and rinsing nozzles" (p. 23).

**Note:** It is advisable to increase the forward speed (double if possible) and reduce the pressure to 20 psi (1.5 bar).

2. Select and use the appropriate protective clothing. Select detergent suitable for cleaning and suitable deactivating agents if necessary.
3. Rinse and clean sprayer and tractor externally. Use detergent if necessary.
4. Remove tank filters and suction filters and clean. Be careful not to damage the mesh. Replace suction filter top. Replace filters when the sprayer is completely clean.
5. With the pump running, rinse the inside of the tank. Remember the tank roof. Rinse and operate all components and any equipment that has been in contact with the chemical.

Before opening the distribution valves and spraying the liquid out, decide whether this should be done in the field again or on the soakaway.

6. After spraying the liquid out, stop the pump and fill at least  $\frac{1}{5}$  of the tank with clean water. Note that some chemicals require the tank to be completely filled. Add appropriate detergent and/or deactivating agent, e.g. washing soda or Triple ammonia.

**Note:** If a cleaning procedure is given on the chemical label, follow it closely.

7. Start the pump and operate all controls enabling the liquid to come in contact with all the components.

**Note:** The Safety Valve (ECP only) should be "purged" with clean water every time the tank is cleaned. This is done by turning the Select Function handle to the SAFETY VALVE PURGE arrow for several seconds while the pump is running.

Leave the distribution valves until last. Some detergents and deactivating agents work best if left in the tank for a short period. Check the label. The Self-Cleaning Filter can be flushed by removing the by-pass hose from the bottom of the filter. Stop the pump and remove the hose. Start the pump for a few seconds to flush filter. Be careful not to lose the restrictor nozzle.

8. Drain the tank and let the pump run dry. Rinse inside of the tank, again letting the pump run dry.



**IMPORTANT!** If the sprayer is equipped with a centrifugal pump (ECPC), do not run pump dry for longer than 3 seconds. Otherwise severe damage to the pump will occur.

9. If the pesticides used have a tendency to block nozzles and filters, remove and clean them now.
10. Replace all the filters and nozzles and store the sprayer. If, from previous experiences, it is noted that the solvents in the pesticide are particularly aggressive, store the sprayer with the tank lid open.

**Note:** If the sprayer is cleaned with a high pressure cleaner lubrication of the entire machine is recommended.

## Cleaning and maintenance of filters

Clean filters ensure:

- Sprayer components such as valves, diaphragms and operating unit are not hindered or damaged during operation.
- Nozzle blockages do not occur while spraying.
- Long life of the pump. A blocked suction filter will result in pump cavitation.

The main filter protecting sprayer component is the suction filter at the top of the tank. Check it regularly.

**Note:** The HARDI® Flush & Rinse system is available on the New NAVIGATOR sprayers. It offers both the flushing of internal components and also a highly effective internal rinsing system of the sprayer tank.



# Maintenance

## Lubrication

### About lubricants

- Always store lubricants clean, dry and cool - preferably at a constant temperature - to avoid contamination from dirt and water condensation.
- Keep oil filling jugs, hoppers and grease guns clean, and clean the lubricating points thoroughly before lubricating.
- Avoid skin contact with oil products for longer periods.
- **Note:** If the sprayer is cleaned with a high pressure cleaner or fertilizer has been used, lubrication of all sections is recommended.

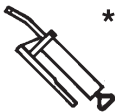
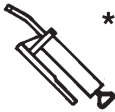
### Recommended lubricants

Lubricating points		Lubricant	
Ball bearings		A	Universal Lithium grease, NLGI No. 2
Slide bearings		B	Lithium grease with Molybdenumdisulphide or graphite
Oil lubricating points		C	SAE 80W/90 Gear oil CASTROL EPX 80/W90 SHELL SPIRAX 80W/90 MOBIL MOBILUBE 80W/90

#### \* Guidelines - greasing

- Pump grease into zerks until new grease becomes visible.

# Maintenance

## Lubrication schedule

**B - 50h**

Operating hours

Type of lubricant

**5**

Position on the sprayer

**6**



**1**  
**2**  
**3**

**4**

**5**



**7**

# Maintenance

1

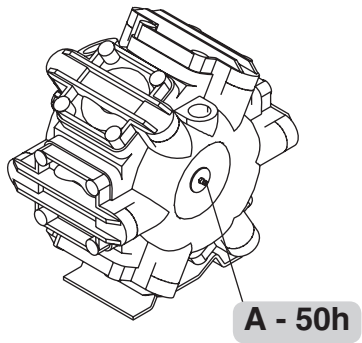

2

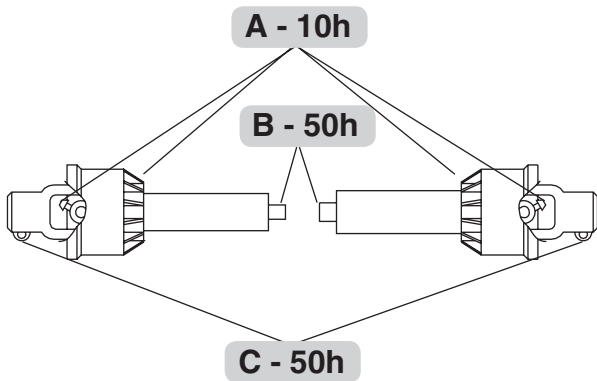

3

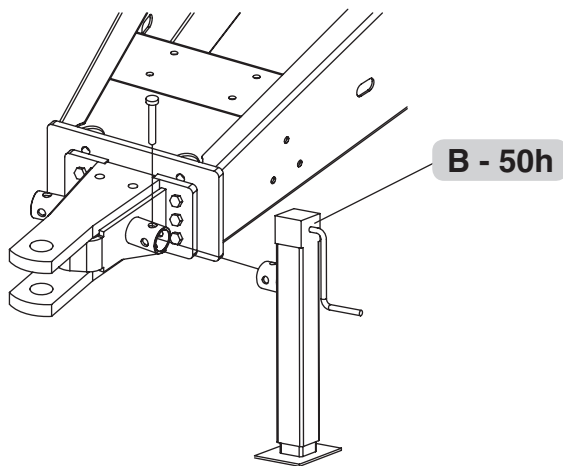

4

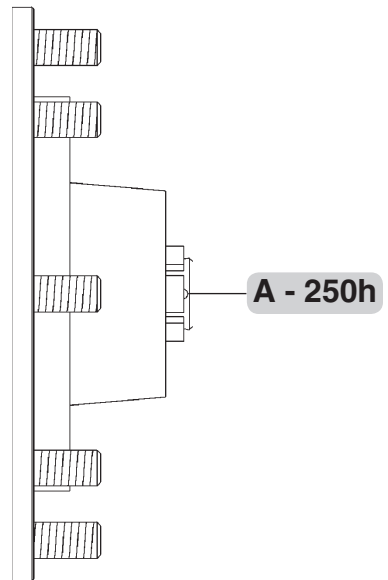

5

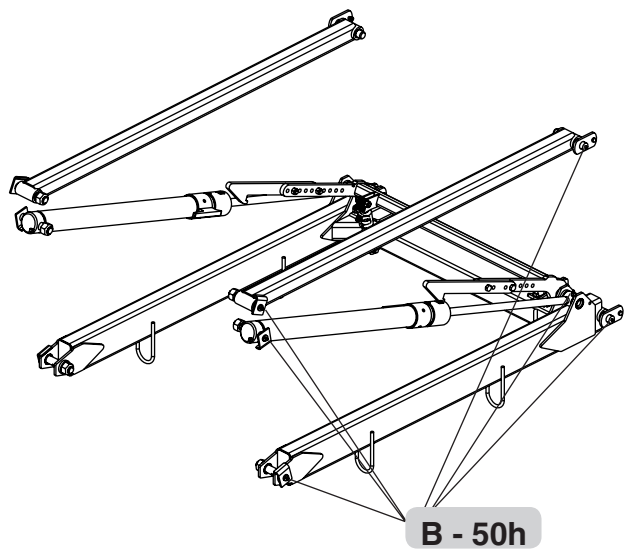

# Maintenance

6

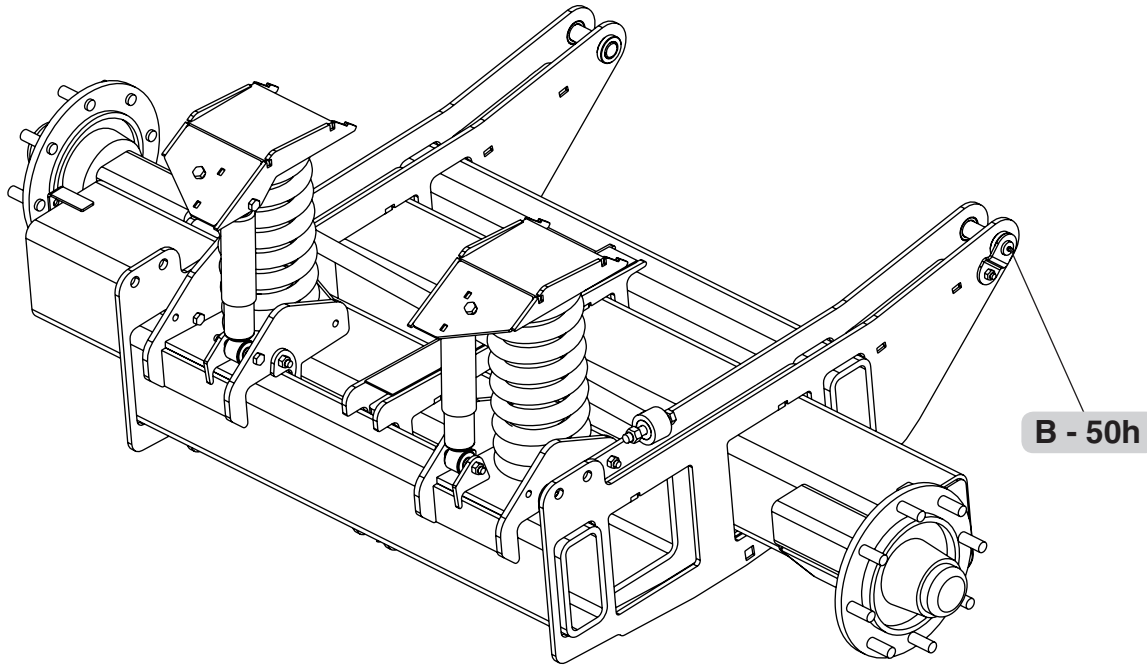

7

C - 500h

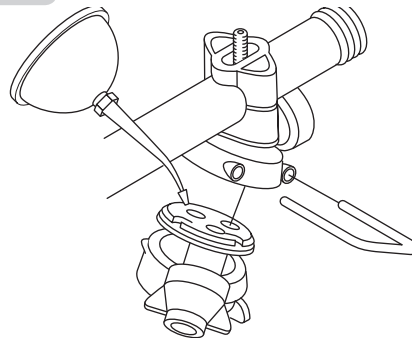



# Maintenance

## Service and maintenance intervals

Service and maintenance intervals for HARDI® New NAVIGATOR.

### 10 Hours or Daily (Whichever occurs first)

- 1 Suction filter: Clean.
- 2 Self cleaning filter: Check and clean filter element, if necessary.
- 3 In-Line filters (If fitted): Clean.
- 4 Nozzle filters: Clean.
- 5 Spraying circuit: Check for leaks.
- 6 P.T.O. Shaft: Grease as in diagram (p. 31).

### 50 Hours or Weekly (Whichever occurs first)

#### Do all previous +

- 7 Wheel studs and nuts: Re-tighten.
- 8 Drawbar bolts: Re-tighten.
- 9 Tires: Check pressure.
- 10 P.T.O. shaft: Check condition of protection guards. Lubricate as in diagram (p. 31).
- 11 Pump: Grease as in diagram (p. 31).
- 12 Hitch: Grease as in diagram (p. 31).

### 250 Hours or Monthly (Whichever occurs first)

#### Do all previous +

- 13 Wheel bearings: Check, grease (p.31) and adjust if necessary.
- 14 Hoses and tubes: Check for possible damage and proper attachment.
- 15 Support Leg: Grease as in diagram (p. 31).

### 1000 Hours or Yearly (Whichever occurs first)

#### Do all previous +

- 16 Wheel bearings: Dismantle, check, grease and adjust.
- 17 P.T.O. shaft: Replace protection guard bearings.

### 10 Hours / Daily Service

#### Suction filter

To service the suction filter:

- 1 Pull the steel clip (**A Fig 29**) out.
- 2 Lift suction hose fitting (**B Fig 29**) from the housing.
- 3 The filter guide and filter (**C Fig 29**) can now be removed.

To reassemble:

- 1 Press the guide onto the filter end.
- 2 Place filter into the housing with the guide facing up.
- 3 Ensure the O-ring (**D Fig 29**) on the hose fitting is in good condition and lubricated.
- 4 Refit suction hose (**B Fig 29**) and steel clip (**A Fig 29**).

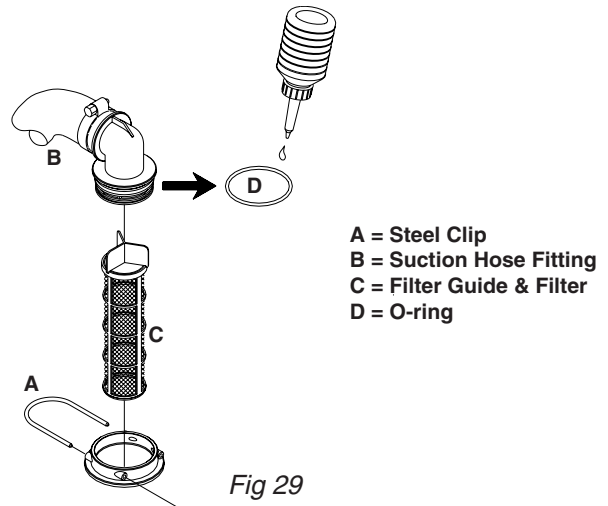

Fig 29

#### Self cleaning filter (ECP only)

Read Self cleaning filter (Page 20) before continuing.

- 1 Unscrew the filter nut (**A Fig 30**) and open the filter.
- 2 Check the filter element (**B Fig 30**), clean if necessary and check there are no residues on any part of the filter hoses.
- 3 Lubricate the O-ring (**C Fig 30**).
- 4 Reassemble the filter.

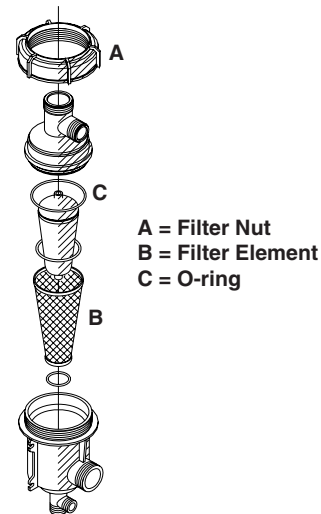

Fig 30

#### In-Line filters (If fitted)

If the sprayer is equipped with In-line filters, unscrew the filter bowl to inspect and clean a filter (Fig 31). Lubricate O-rings.

Alternative filter elements are available. Refer to *Filters*, (p. 20).

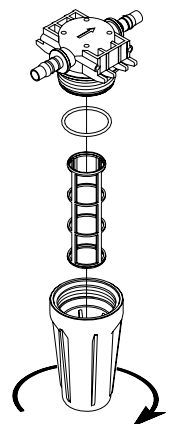

Fig 31

# Maintenance

## Nozzle filters

- 1 Remove the nozzle (Fig 32).
- 2 Check the nozzle and the filter.
- 3 Clean the filter.
- 4 Refit filter and nozzle. Repeat for each nozzle.



Fig 32

## Spraying circuit

Fill with clean water, operate all functions and check for leaks, use higher spray pressure than normal. Check nozzle spray patterns visually using clean water.

### 50 Hours / Weekly Service

## Wheel studs and nuts

Tighten wheel studs and nuts as follows with the following torque wrench settings:

Wheel hub to rim plate: 362 Ft/lb (490 Nm)

Rim plate to rim: 230 Ft/lb (310 Nm)

Tightening sequence (Fig 33):

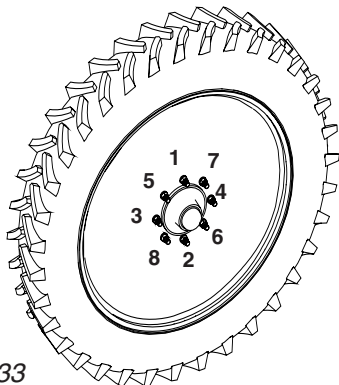

Fig 33

## Draw bar bolts

The draw bar bolts must be tightened as follows:

- 1 Jack up chassis so there is no load on the drawbar.
- 2 Tighten the chassis bolts (A Fig 34) - 554 Ft/lb (750 Nm)
- 3 Tighten the hitch bolts (B Fig 34) - 162 Ft/lb (220 Nm)

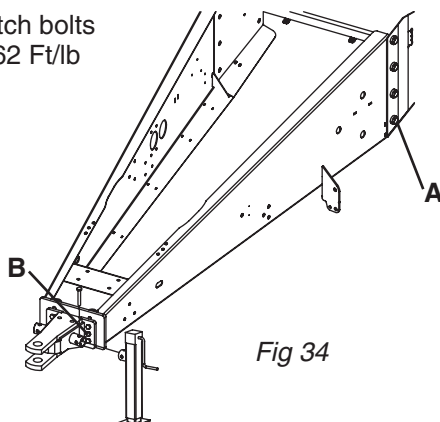

Fig 34

## Tires

Check the tire pressures according to the table below.

Tire Size	Recommended Inflation Pressure
	PSI (kPa)
12.4 x 42	25 (175)
11.2 x 38	35 (240)



**WARNING!** Never inflate tires more than to the pressure specified in the table. Over-inflated tires can explode and cause severe personal injuries.

## P.T.O. shaft

Check function and condition of the P.T.O. shaft's protection guards. Replace any damaged parts immediately.

### 250 Hours / Monthly Service

## Wheel bearings

Check for play in the wheel bearings:

- 1 Place stop wedges in front of and behind the left hand wheel and jack up the right hand wheel.
- 2 Rock the right hand wheel to discover possible play in the bearings.
- 3 If there is any play, support the wheel axle to prevent the trailer from falling down from the jack.
- 4 Remove the hub cap (A Fig 35) and cotter pin (B Fig 35). Turn the wheel and tighten castle nut (C Fig 35) until slight resistance in wheel rotation is felt.
- 5 Loosen castle nut until first notch - horizontal or vertical - is aligned with cotter pin hole in the shaft.
- 6 Fit a new cotter pin and bend it.
- 7 Fill the hub cap with fresh grease and press it on to the hub again.
- 8 Repeat the procedure on the left hand wheel.

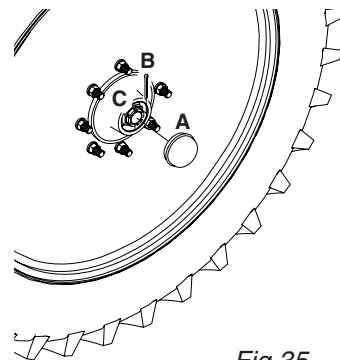

Fig 35

# Maintenance

## Hoses and tubes

Check all hoses and tubes for possible damage and proper attachment. Replace damaged hoses or tubes.

### 1000 Hours / Yearly Service

## Wheel bearings

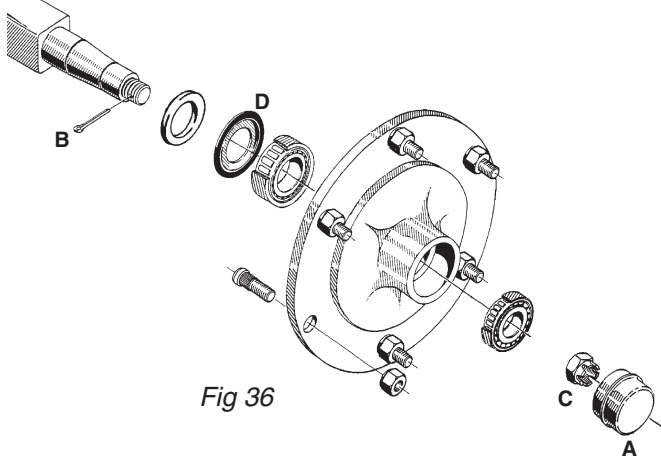

Fig 36

Check the condition of the bearings the following way:

- 1 Place stop wedges in front of and behind the left hand wheel and jack up the right hand wheel.
- 2 Support the trailer with axle stands.
- 3 Remove the wheel.
- 4 Remove the hub cap (**A Fig 36**), cotter pin (**B Fig 36**) and castle nut (**C Fig 36**).
- 5 Pull off wheel hub. Use a wheel puller if necessary.
- 6 Check roller bearings for discoloration and wear - replace if worn or damaged.
- 7 Assemble the hub and bearings using a new sealing ring (**D Fig 36**).
- 8 Fill the hub and bearings with fresh grease before fitting to the shaft.
- 9 Fit castle nut. Rotate hub and tighten the castle nut until a slight rotation resistance is felt.
- 10 Loosen the castle nut again until the first notch is aligned with the cotter pin hole in the shaft.
 

**NOTE!** The shaft has a vertical and a horizontal cotter pin hole. Use the one first aligned with the notch when loosening the castle nut.
- 11 Fit a new cotter pin and bend it.
- 12 Fill the hub cap with fresh grease and carefully press it onto the hub.
- 13 Fit the wheel again and tighten the wheel nuts. (Refer *50 Hours / Weekly Service* (Page 34) for torque wrench setting. Tighten all bolts to half the specified torque first, then to the full specified torque.
- 14 Tighten again after 10 hours of work. Check the torque every day until it is stabilized.
- 15 If you do not feel totally confident changing wheel bearings, contact your HARDI® dealer's workshop.

## Occasional maintenance

Maintenance and replacement intervals for the next points depend very much on conditions under which sprayer operates, and are therefore impossible to specify.

## Pump valves and diaphragms replacement (363/463 pumps)

**NOTE!** It is recommended that if one or more diaphragms and/or valves need replacing they all should be replaced

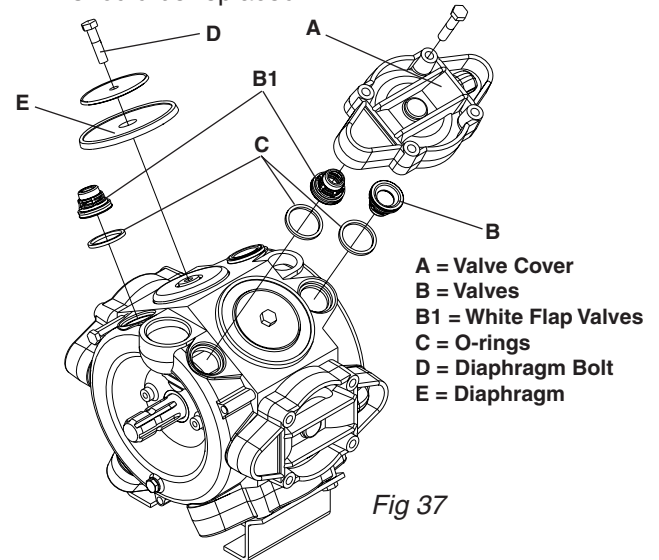

Fig 37

Diaphragm pump overhaul kit (valves, seals, diaphragms, etc.)

Pump model	HARDI® part No.
363	750342
463	750343

## Changing valves

- 1 Remove the valve covers (**A Fig 37**). Before changing the valves (**B & B1 Fig 37**) note their orientation so they are replaced correctly.
- 2 The two white flap valves (**B1 Fig 37**) must be placed in the valve openings as shown. It is recommended to use new O-rings (**C Fig 37**) when changing or checking the valves.

## Changing diaphragms

- 1 With the valve covers removed as explained above, remove the diaphragm bolts (**D Fig 37**).
- 2 The diaphragms (**E Fig 37**) may now be changed.
- 3 If fluids have reached the crankcase, re-grease the pump thoroughly. Also check the drain hole at the bottom of the pump is not blocked.

# Maintenance

**NOTE!** When tightening diaphragm cover it must be ensured that diaphragm is **in neutral or out**. If the diaphragm is in negative, the edge of the diaphragm is not seated correctly in the diaphragm cover. This will damage the diaphragm so it cannot seal correctly after having been dismantled and re-assembled.

You must rotate the pump until the diaphragm is neutral or out.

- 4 Reassemble with torque settings shown in *Torque settings* (below).

**IMPORTANT!** Before tightening the 4 bolts for the diaphragm cover (**A Fig 37, D Fig 39**) the diaphragm must be positioned between center and top to ensure correct sealing between diaphragm pump housing and diaphragm cover (*Fig 38*). Turn crank shaft if necessary.

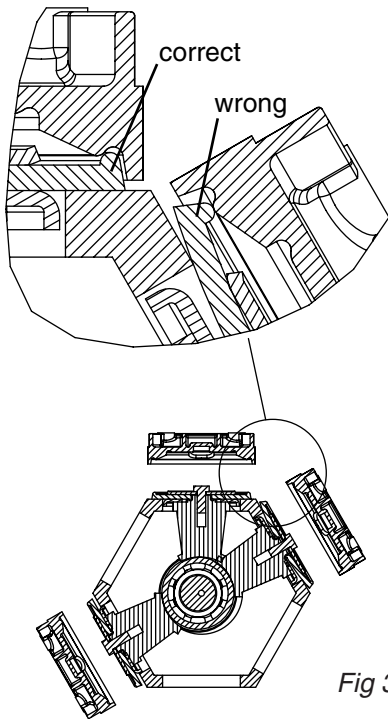

Fig 38

## Torque Settings for 363/463 pumps

Pump Model	Valve Cover Ft/lb(Nm)	Diaphragm Bolt Ft/lb(Nm)
363	50 (70)	45 (60)
463	65 (90)	60 (80)

1 Ft/lb = 1.36 Nm

## Pump valves and diaphragms replacement (1302 pumps)

**NOTE!** It is recommended that if one or more diaphragms and/or valves need replacing they all should be replaced.

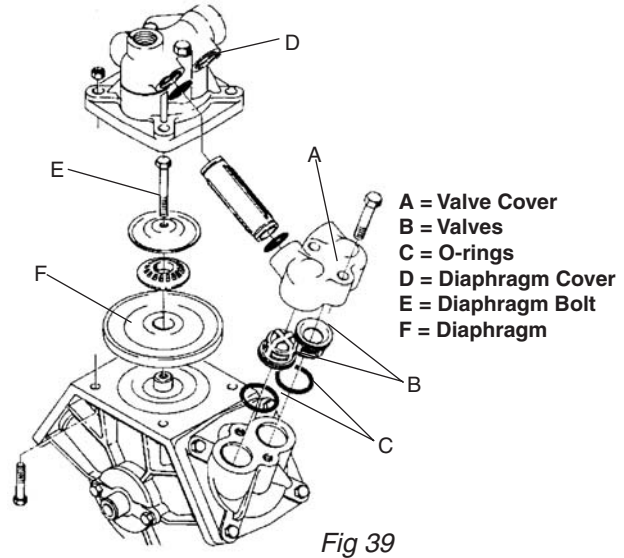

Fig 39

Diaphragm pump overhaul kit (valves, seals, diaphragms, etc.)

Pump model	HARDI® part No.
1302	750175

## Changing valves

- 1 Remove the valve covers (**A Fig 39**). Before changing the valves (**B Fig 39**) note their orientation so they are replaced correctly. It is recommended to use new O-rings (**C Fig 39**) when changing or checking the valves.

## Changing diaphragms

- 1 Remove the diaphragm covers (**D Fig 39**).
- 2 Remove the diaphragm bolts (**E Fig 39**).
- 3 The diaphragms (**F Fig 39**) may now be changed.
- 4 If fluids have reached the crankcase, re-grease the pump thoroughly. Also check the drain hole at the bottom of the pump is not blocked.
- 5 Reassemble with torque settings shown below.

## Torque Settings for 1302 pumps

Pump Model	Valve Cover Ft/lb(Nm)	Diaphragm Bolt Ft/lb(Nm)	Diaphragm Cover
1302	45 (60)	45 (60)	50 (70)

1 Ft/lb = 1.36 Nm

# Maintenance

## Cone check/replacement ECP/ECPC operating unit

If it becomes difficult to build up sufficient pressure or if pressure fluctuations occur, it may be necessary to replace the cone and cylinder. A HARDI® kit is available for this purpose. Ref. no. 741293.

1. Remove 4 x screws (A Fig 40) and remove the housing.
2. Remove 4 x screws (B Fig 40).

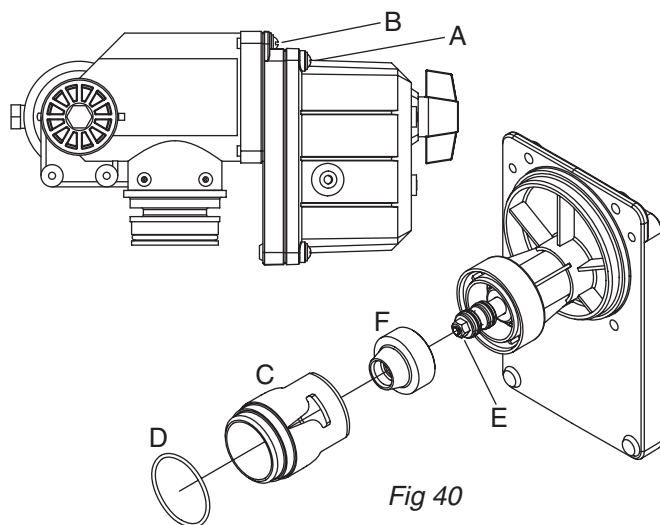

3. Replace cylinder (C Fig 40) and O-ring (D Fig 40).
4. Loosen the nut (E Fig 40), remove and replace the cone (F Fig 40).
5. Reassemble in reverse order.

## Cone check/replacement, ECP/ECPC distribution valve

Periodically check the distribution valves for proper sealing. Do this by running the sprayer with clean water and open all distribution valves.

Cautiously remove the clip (A Fig 41) and pull out the hose (B Fig 41) for the pressure equalization device. When the housing is drained, there should be no liquid flow through the pressure equalization device. If there is any leakage, the valve cone (E Fig 41) must be changed.

Remove the clip (C Fig 41) and lift the motor housing off the valve housing. Then unscrew the screw (D Fig 41) and replace the valve cone (E Fig 41). Reassemble in reverse order.

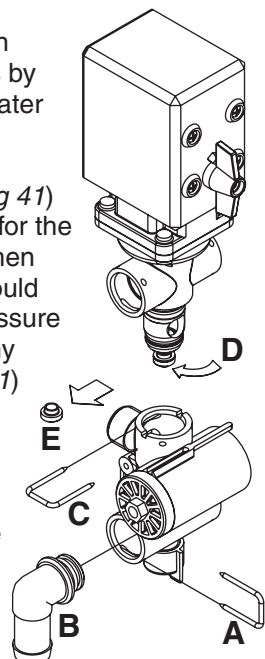

Fig 41

## Wear bushing replacement, boom lift

The wear bushings are inspected and replaced before they are worn through.

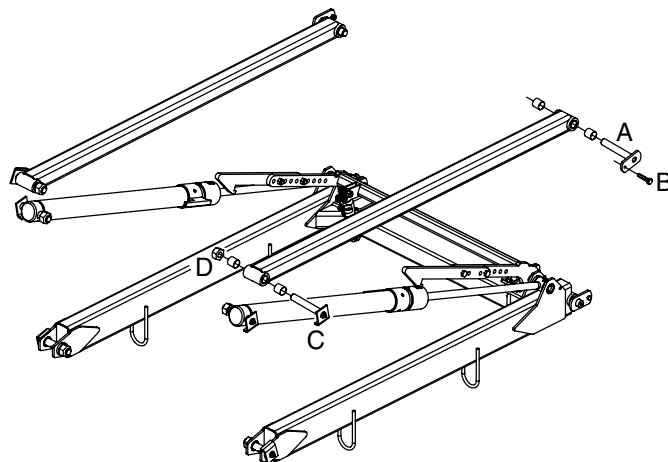

Fig 42

1. Connect the trailer to a tractor and unfold the booms to working position.
2. Lift the boom center frame with a lifting device and support it until the load is taken off the Paralift™ arms.
3. Remove pin (A Fig 42) by removing anchor bolt (B Fig 42). Remove pin (C Fig 42) by removing nut (D Fig 42). Remove the upper Paralift™ arm and replace the wear bushings.
4. Refit the arm.
5. Repeat this on the other upper arm.
6. The lower arms must be disconnected simultaneously. Grease all grease nipples.
7. Remove the lifting gear again.

## Shock absorbers

If the shock absorbers loose their efficiency or start leaking oil, they should be replaced.

# Maintenance

## Level indicator adjustment

The level indicator reading should be checked regularly.

When the tank is empty, the float should lie on the stop pin of the rod, and the O-ring on the indicator should be positioned at the top position line (A Fig 43).

If any deviation is found, pull out the plug (B Fig 43), loosen screws (C Fig 43), and adjust the length of the cord.

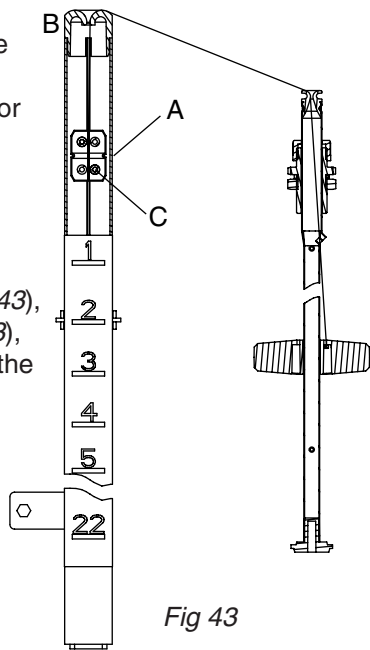

Fig 43

## Cord replacement, level indicator

If the cord on the level indicator has to be changed, the float guide pole is removed:

1. Remove the tank drain valve (see paragraph "Main tank drain valve") and loosen the fitting holding the pole in position.
2. Pull the pole down through the drain valve hole till it is free in the top of the tank.
3. The pole can now be taken out of the tank through the filling hole.



**DANGER!** Do not attempt to enter the tank - the float pole can be removed from outside the tank!

## Seal replacement, drain valve

If the main tank drain valve leaks, the seal and seat can be changed the following way.



**DANGER!** Do not enter the inside of the tank - the parts can be changed from underneath the tank!



**WARNING!** Use eye / face protection mask when dismantling the tank drain valve!

1. Make sure the tank is empty and clean.
2. The valve must be closed and the string loose.

3. Pull out the clip (A Fig 44) and pull down connecting piece (B Fig 44). The entire valve assembly can now be pulled out.
4. Check cord and valve flap assembly (C Fig 44) for wear, replace seal (D Fig 44) and assemble again.
5. Assemble the valve assembly again using a new valve seat (E Fig 44). Lubricate O-rings (F Fig 44) before assembly.
6. Fit clip (A Fig 44) again.

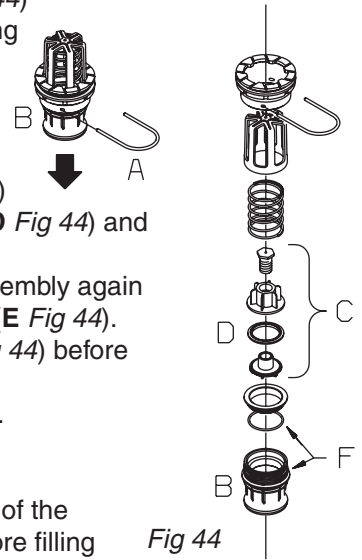

Fig 44

NOTE! Check the function of the valve with clean water before filling chemicals into the tank.

## Nozzle tubes and fittings

Poor seals are usually caused by:

- missing O-rings or gaskets
- damaged or incorrectly seated O-rings
- dry or deformed O-rings or gaskets
- foreign bodies

In case of leaks:

### DO NOT overtighten.

Disassemble, check condition and position of O-ring or gasket. Clean, lubricate and reassemble.

The O-ring must be lubricated **ALL THE WAY ROUND** before fitting on to the nozzle tube. Use non-mineral lubricant.

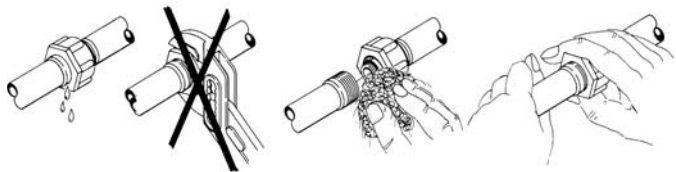
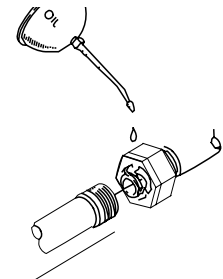

For **RADIAL** connections only hand-tighten them.

For **AXIAL** connections, a little mechanical leverage may be used.

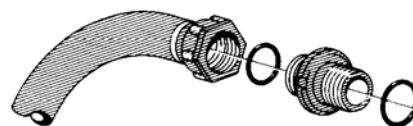

# Maintenance

## Off-season storage

When the spraying season is over, you should devote some extra time to the sprayer. If chemical residues are left over in the sprayer for long periods, it can reduce the life of the individual components. To preserve the sprayer and protect the components, carry out the following off-season storage program:

1. Clean the sprayer completely - inside and outside - as described under "Cleaning of the sprayer". Make sure that all valves, hoses and auxiliary equipment have been cleaned with detergent and flushed with clean water afterwards, so no chemical residues are left in the sprayer.
2. Replace any damaged seals and repair any leaks.
3. Empty the sprayer completely and let the pump work for a few minutes. Operate all valves and handles to drain as much water out of the spraying circuit as possible. Let the pump run until air is coming out of all nozzles. Remember to drain the flush tank also.
4. Pour appr. 13 gal. (50 liters) anti-freeze mixture consisting of 1/3 automotive anti-freeze and 2/3 water into the tank.
5. Engage the pump and operate all valves and functions on the MANIFOLD system, ECP unit, CHEM FILLER, etc. allowing the anti-freeze mixture to be distributed around the entire circuit. Activate the ECP main on/off switch and distribution valves so the anti-freeze is sprayed through the nozzles as well. The anti-freeze will also prevent O-rings, seals, diaphragms, etc. from drying out.
6. When the sprayer is dry, remove rust from any scratches or damages in the paint and touch up the paint.
7. Lubricate all lubricating points according to the lubricating scheme - regardless of intervals stated.
8. Remove the glycerine-filled pressure gauges and store them in a vertical position in frost free conditions.
9. Apply a thin layer of anti-corrosive oil (e.g. SHELL ENSIS FLUID, CASTROL RUSTILLO or similar) on all metal parts. Avoid oil on rubber parts, hoses and tires.
10. Fold the boom in transport position and relieve pressure from all hydraulic functions.
11. All electric plugs and sockets are to be stored in a dry plastic bag to protect them against moisture, dirt and corrosion.
12. Remove all the control boxes (including any rate controller/monitor control box and display) from the tractor and store them in a dry and clean location.
13. Wipe hydraulic snap-couplers clean and fit the dust caps.
14. Apply grease on all hydraulic ram piston rods which are not fully retracted in the barrel to protect against corrosion.
15. Jack up the axle and place wooden blocks under the wheels to prevent moisture damage and deformation of the tires. Tire black can be applied to the tire side walls to preserve the rubber.
16. To protect against dust, the sprayer can be covered by a tarpaulin. Ensure ventilation to prevent condensation.

## Preparation after off-season storage

After a storage period, the sprayer should be prepared for the next season the following way:

1. Remove the cover. (If fitted)
2. Remove the blocks from under the wheels and adjust the tire pressure.
3. Wipe off the grease from hydraulic ram piston rods.
4. Fit the pressure gauges again. Seal with Teflon tape.
5. Connect the sprayer to the tractor, including hydraulics and electrics.
6. Check all hydraulic and electric functions.
7. Empty the tank for remaining anti-freeze.
8. Rinse the entire liquid circuit on the sprayer with clean water.
9. Fill with clean water and check all functions.

# Equipment and Accessories

## Equipment - Standard and Optional

### Platform

The working platform also serves as an optional flush tank. In order to utilize the platform as a flush tank, a special flush tank accessory hose kit can be ordered.



Working Platform / Flush Tank

The combined flush tank & working platform can be easily tilted to one side in order to provide complete access for general cleaning, inspection, service or maintenance of fluid components, fittings and accessories, etc.



Working Platform tilted for access

### Step (optional)

The fold-down step provides easy and safe access to the working platform, and can be folded up during field applications for less crop damage.



Step down



Step Locked Up

### Tank Level Indicator

The actual tank level in the main tank can be observed on the tank level indicator located at the front of the sprayer.



### 4" Boom Pressure Gauge

A large and easy to read 4" boom pressure gauge is available to replace the standard 2-1/2" gauge. This gauge is to be mounted on the front handrail allowing the operator to monitor the boom pressure for more accurate control of the application rate.

### Quick Fill System (optional)

The Quick Fill System allows filling of the main tank and (optional) Flush Tank from an overhead fill tank or other water supply source. An optional filling filter is also available.



Quick Fill



# Equipment and Accessories

## Foam marker system (optional)



Foam Marker Tank



Foam Marker Drop Assembly

The Foam Marker helps prevent skipping or overlapping during spray application of spray solution, which can be costly. HARDI® Foam Marker features a trailer mounted compressor, poly tank, extruded foamer hoses and in-cab electrical controls providing right or left drop selection and the rate/quality of foam droplets. The Foam Marker is available with 20 gal. (75 Liter) tank or 40 gal. (150 Liters) tank. Refer to the Foam Marker Operator's Manual for complete instructions.

## Flush System (optional)

Flush system provides a means to be able to flush the pump, controls, boom feed lines and complete boom and nozzles with clean water from a 130 gallon tank. Refer to the Flush & Rinse System™ Operator's Manual for complete operational instructions.



Flush Tank

The Rinse system can be added to the flush system. This provides a means to rinse the main tank using pressurized water to spray the inside of the tank through specially designed spinning nozzles. See the Flush & Rinse™ Operator's Manual for complete operational instructions.



Rinse Nozzles

# Equipment and Accessories

## HARDI® Monitor 1500 (optional)



The HARDI® Monitor 1500 monitors the application rate. When used with the electric control unit switch box, correct area covered and up to 8 spray boom section control is possible.

## HARDI® Controller 2500 (optional)



The HARDI® Controller 2500 permits automatic control of the application rate. This allows you to concentrate on driving as the rate is automatically maintained by the HC 2500. Press the “up” or “down” arrow keys to change the application rate. Easy, quick and simple. Up to 8 spray boom section control is possible.

## Mustang 3500 Controller (optional)



The Mustang 3500 Controller offers fully integrated boom controls (3 - 7 sections), integrated foam marker controls, integrated TWIN FORCE controls, 3 possible preprogrammed application rate settings, 9 different field counters, DGPS compatible, prepared for communication with Precision Farming Terminals and pocket PC's (iPAQ - models: 3650, 3670), variable rate application, rain & dust proof and 3 year warranty.

# Troubleshooting

---

## Operational problems

In cases where breakdowns have occurred, the same factors always seem to be in question:

1. Minor leaks on the suction side of the pump will reduce the pump capacity or stop the suction completely.
2. A clogged suction filter will hinder or prevent suction so that the pump does not operate satisfactorily.
3. Clogged up pressure filters will result in increasing pressure at the pressure gauge but lower pressure at the nozzles.
4. Foreign bodies stuck in the pump valves with the result that these cannot close tightly against the valve seat. This reduces pump efficiency.
5. Poorly reassembled pumps, especially diaphragm covers, will allow the pump to suck air resulting in reduced or no capacity.
6. Hydraulic components that are contaminated with dirt result in rapid wear to the hydraulic system.

Therefore ALWAYS check:

1. Suction, pressure and nozzle filters are clean.
2. Hoses for leaks and cracks, paying particular attention to suction hoses.
3. Gaskets and O-rings are present - and in good condition.
4. Pressure gauge is in good working order. Correct dosage depends on it.
5. Operating unit works properly. Use clean water to check.
6. Hydraulic components are maintained clean.

# Troubleshooting

## Liquid system

FAULT	PROBABLE CAUSE	CONTROL/REMEDY
No spray from boom when turned on.	Air leak on suction line.	Check if suction filter O-ring is sealing. Check suction tube and fittings. Check tightness of pump diaphragm and valve covers.
	Air in system (ECPC).	Bleed air from centrifugal pump.
	Suction/pressure filters clogged.	Clean filters. Check yellow suction pipe is not obstructed or placed too near the tank bottom.
Lack of pressure.	Incorrect assembly.	Restrictor nozzle in Self-Cleaning Filter not fitted. Safety valve spring for Self-Cleaning Filter not tight. Too little distance between yellow suction pipe and tank bottom.
	Pump valves blocked or worn.	Check for obstructions and wear.
	Defect pressure gauge.	Check for dirt at inlet of gauge.
Pressure dropping.	Filters clogging.	Clean all filters. Fill with cleaner water. If using powders, make sure agitation is on.
	Nozzles worn.	Check flow rate and replace nozzles if it exceeds 10%.
	Tank is air tight.	Check vent is clear.
	Sucking air towards end of tank load.	Lower pump r.p.m.
Pressure increasing	Pressure filters beginning to clog.	Clean all filters.
Formation of foam.	Air is being sucked into system.	Check tightness / gaskets / O-rings of all fittings on suction side.
	Excessive liquid agitation.	Reduce pump r/min. Check safety valve for Self-Cleaning Filter is tight. Ensure returns inside tank are present. Use foam damping additive.
Liquid leaks from bottom of pump.	Damaged diaphragm.	Replace. See Changing of valves and diaphragms.
Excessive hose vibrations.	Suction side air leak.	Check for cracked hose, loose clamps or bad suction valve.

# Troubleshooting

## Hydraulic system

FAULT	PROBABLE CAUSE	CONTROL/REMEDY
Boom slow/erratic.	Air in system	Loosen ram connection and activate hydraulics until oil flow has no air in it (not whitish).
	Tractor hydraulic flow control	Open or close until desired speed is achieved
	Insufficient hydraulic pressure	Remember oil must be at operating temperature.
	Insufficient amount of oil in tractor reservoir	Check output pressure of tractor hydraulics. Minimum for sprayer is 2000 psi (130 bar).
	Restrictor or regulation valve blocked	Check and top up if needed.
Ram not functioning.	Power supply	Secure boom Dismantle and clean.
Hydraulic system fold/tilt functions will not operate	Various	Check for proper 12V power supply
One function (fold or tilt) will not operate	Various	Check for defective switch(es). Check continuity of cables. Check for operation of applicable solenoid (coil not activating or plunger stuck). Check for short circuit in wiring junction box at rear of sprayer. Dirt in the restrictor port of the cylinder.
Multiple hydraulic functions with one switch activated		Check for correct solenoid electric/hydraulic hook-up. Check for short circuit in wiring in the junction box at rear of sprayer.

# Troubleshooting

## ECP/ECPC Operating unit

FAULT	PROBABLE CAUSE	CONTROL/REMEDY
Operating unit not functioning	Blown fuse(s).	Check mechanical function of microswitches. Use cleaning/lubricating agent if the switch does not operate freely.  Check motor. 450-500 milli-Amperes max. Change motor, if over.
	Wrong polarity.	Brown - pos. (+). Blue - neg. (-).
	Valves not closing properly.	Check valve seals for obstructions.  Check microswitch plate position. Loosen screws holding plate a 1/2 turn.
	No power.	Wrong polarity. Check that brown is pos. (+), Blue is neg. (-).  Check print plate for dry solders or loose connections.  Check fuse holder are tight around fuse.

## Foam marker problems

FAULT	PROBABLE CAUSE	CONTROL/REMEDY
Compressor will not run.	Various	Short in electrical system or bad compressor. 12 volt supply not connected or bad connection. Weak power supply. Fuse blown. Defective switch in control box.
Compressor runs, but will not make foam.	Various	Solenoid not working. Not enough foam concentrate. Solenoid valve plugged. Weak power supply.
Will not make enough foam.	Various	Line leak or line pinched. Solenoid valve plugged. Weak foam concentrate mixture. Water too hard (add water softener).
Foam drops will not last.	Various	Not enough foam concentrate. Frequency valve not opened enough. Weak foam concentrate. Water too hard (add water softener).
Keeps blowing fuses	Various	Short in electrical system or bad compressor. Weak power supply. Tank filter plugged.

# Troubleshooting

## Flush & Rinse™ System problems

FAULT	PROBABLE CAUSE	CONTROL/REMEDY
System will not flush (pump, control, and boom)	Various	Flush valve not in correct position. P.T.O. not engaged
System will flush, but not rinse.	Rinse valve	Rinse valve not in correct position.
Rinse nozzle has poor output.	Various	Bad flush valve or suction side air leak. Rinse valve not in correct position. Chemical filler pressure selection not in correct position (if so equipped).

## Chemical Filler problems

FAULT	PROBABLE CAUSE	CONTROL/REMEDY
Filler hopper will not empty.	Various	Pressure selection valve not in correct position. Sprayer pump not running.
Filler hopper empties too slow.	Various	Bottom tank discharge valve not open all the way. Restrictor cone from pump supply not the correct size: Black - 1302 & 363 pump White - 463 pump
Filler hopper backfills when bottom tank discharge valve is open.	Various	Restrictor cone from pump supply not the correct size: Black - 1302 & 363 pump White - 463 pump Restrictor cone missing. Restrictor cone on wrong side of the valve. Pump not at full r.p.m.

# Emergency operation

## Emergency operation of the sprayer ECP/ECPC operating unit

In case of electrical failure, it is still possible to manually override all functions of the operating unit. To operate manually, disconnect the multiplug from the ECP or ECPC control box first and operate the handles by hand. It is possible to change pressure and turn booms on or off.

The problem may be due to a blown fuse. An extra fuse is placed inside the box.

**Note:** Since the on-off switch normally operates by shutting off all boom distribution valves, you will need to manually shut off all distribution valves to shut off the complete control unit manually.

Fuse type: 6.3 A

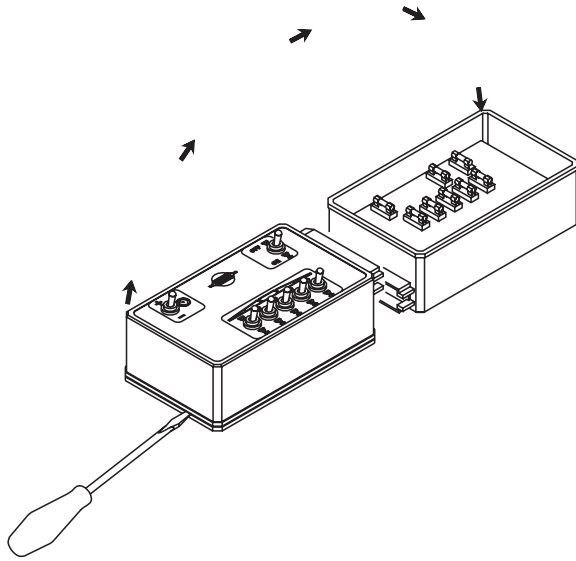



# Technical specifications

## Technical specifications

Overall measurements:

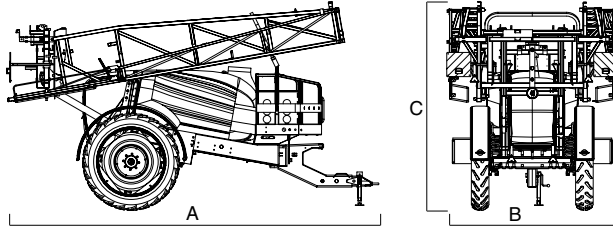

			A	B	C
Tank size	Boom model	Boom Size	Total Length	Total Width	Total Height
1100 Gallon (4160 Liter)	Eagle™ SPB	60' (18 m)	244" (6200 mm)	10.8 ft. (3270 mm)	120" (3050 mm)
1100 Gallon (4160 Liter)	Eagle™ SPC	100' (30 m)	336" (8530 mm)	11.5 ft. (3500 mm)	153" (3880 mm)

SPECIFICATIONS	1100
Main tank capacity	1100 Gallon (4160 Liter)
Flush tank capacity	130 Gallon (500 Liter)
Foam marker tank capacity	20 or 40 gallon (75 or 150 Liter)
<b>Weight:</b>	
60' (18m) Eagle™ boom - Total weight empty	N/A
60' (18m) Eagle™ boom - Tongue weight empty	N/A
100' (30m) Eagle™ boom - Total weight empty	5495 lbs (2494 kg)
100' (30m) Eagle™ boom - Tongue weight empty	935 lbs (425 kg)

Diaphragm pump models:	1302-540	363-540	363-1000	463-540	463-540 HC	463-1000	463-1000 HC
Max. Pump capacity	30 GPM (114 l/min)	49 GPM (182 l/min)	49 GPM (182 l/min)	69 GPM (262 l/min)	85 GPM (322 l/min)	69 GPM (262 l/min)	77 GPM (292 l/min)
Max. working pressure:	0-220 PSI (0-15 bar)	0-220 PSI (0-15 bar)	0-220 PSI (0-15 bar)	0-220 PSI (0-15 bar)	0-220 PSI (0-15 bar)	0-220 PSI (0-15 bar)	0-220 PSI (0-15 bar)

Centrifugal pump models:	ACE 206 & ACE 304
Max. Pump capacity	output will vary with PSI and usage
Max. working pressure:	output will vary with PSI and usage

Note: 463 High Capacity (HC) diaphragm pump fluid systems only for 80'- 100' (24m- 30m) Eagle™ SPC booms.

Note: All weight measurements are approximate values with booms in transport position, flush tank & working platform, clean water tank, chemical inductor and foam marker.

N/A = Not Available

# Technical specifications

## Filters and nozzles

### Filter gauze width

- 30 mesh: 0.023" (0.58 mm)
- 50 mesh: 0.012" (0.30 mm)
- 80 mesh: 0.007" (0.18 mm)
- 100 mesh: 0.006" (0.15 mm)

## Temperature and pressure ranges

Operating temperature range:  
36°F to 104°F (2° to 40° C.)

Operating pressure for safety valve:  
220 psi (15 bar)

## Electrical connections

### Rear lights

#### Position

1. Ground
2. Work lamps
3. LH flashing & turn indicator
4. Free
5. RH flashing & turn indicator
6. Free
7. Free

#### Wire color

- White
- Black
- Yellow
- Red
- Green
- Brown
- Blue

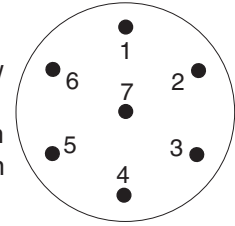

The wiring is in accordance with ANSI/SAE S279.11.

## Electrical connections for ECP/ECPC operating unit

20 pole plug with cable

Number of distribution valve							
6 & 5	4	3 & 2		2 & 3	4	5 & 6	
Wire number or color code							
13	9	9		10	10	14	
G/Y	G/Y	G/Y		11	11	15	
1	1				2	2	
3	3	1		2	4	4	
5		3		4		6	
7	5	5		6	6	8	
9	7				8	10	
11						12	

G/Y = green/yellow

## ECP/ECPC

Number of distribution valves			
	3/4	5/6	7
Valve	Wire number or color code		
B1	1-2	1-2	1-11
B2	3-4	3-4	2-12
B3	5-6	5-6	3-13
B4	7-8	7-8	4-14
B5		9-10	5-15
B6		11-12	6-16
B7			7-17
REG	9-10	13-14	9-10
B8			
G/Y = Green/Yellow			

# Technical Specifications

## EAGLE™ boom hydraulics SPB-HZ and SPC-HZ

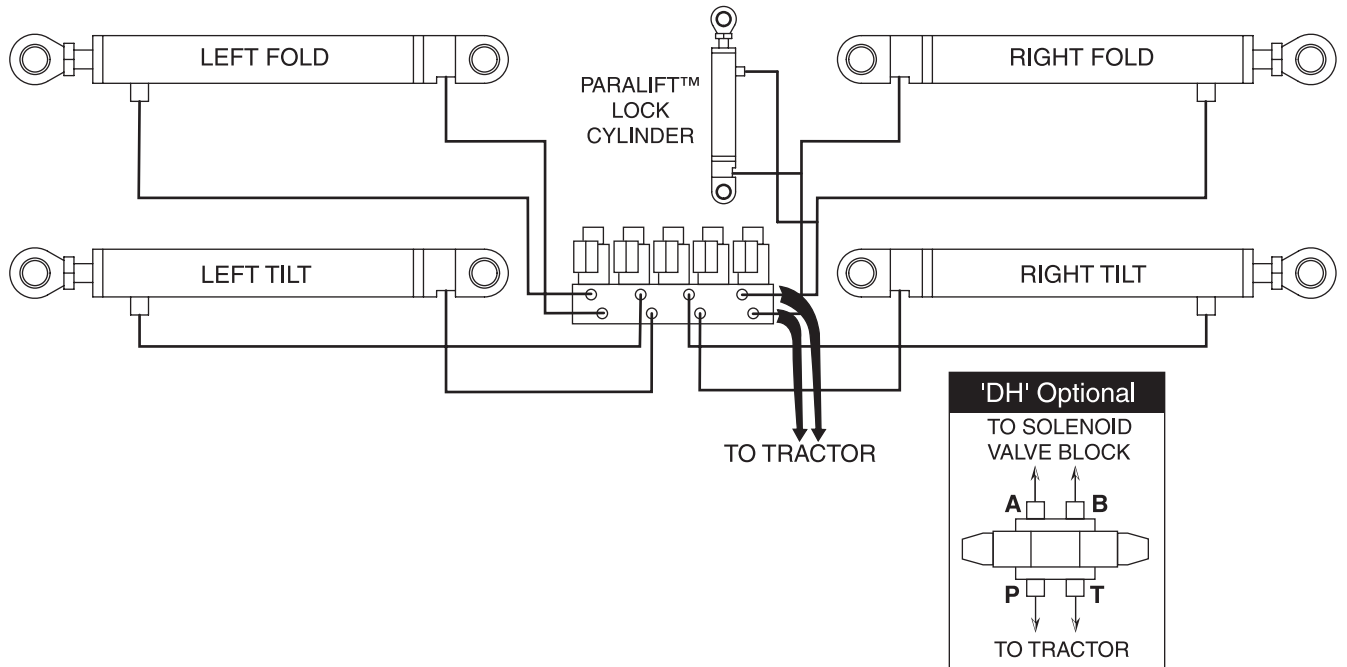

## EAGLE™ boom hydraulics SPB-HY and SPC-HY

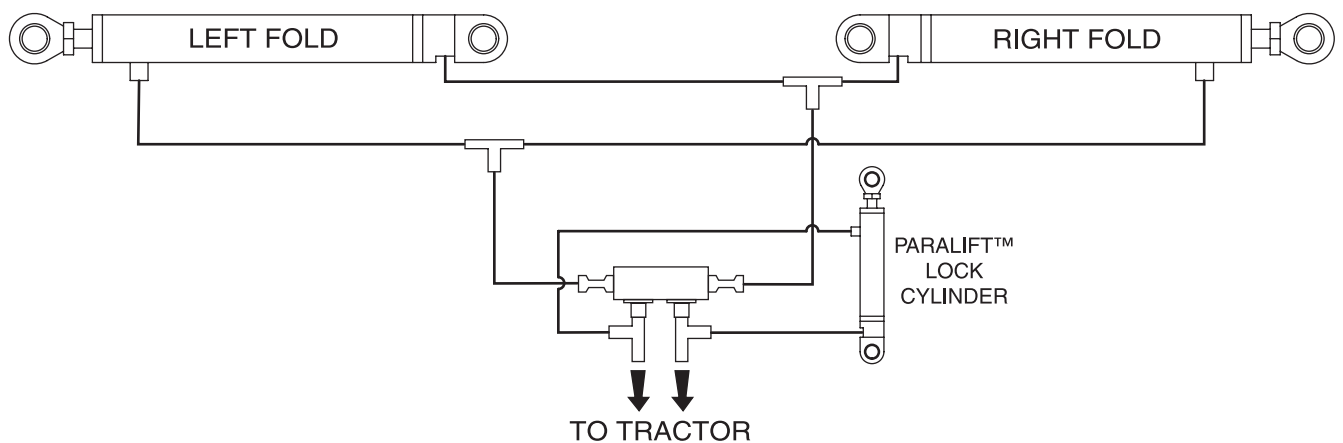

# Technical specifications

## DH Hydraulics

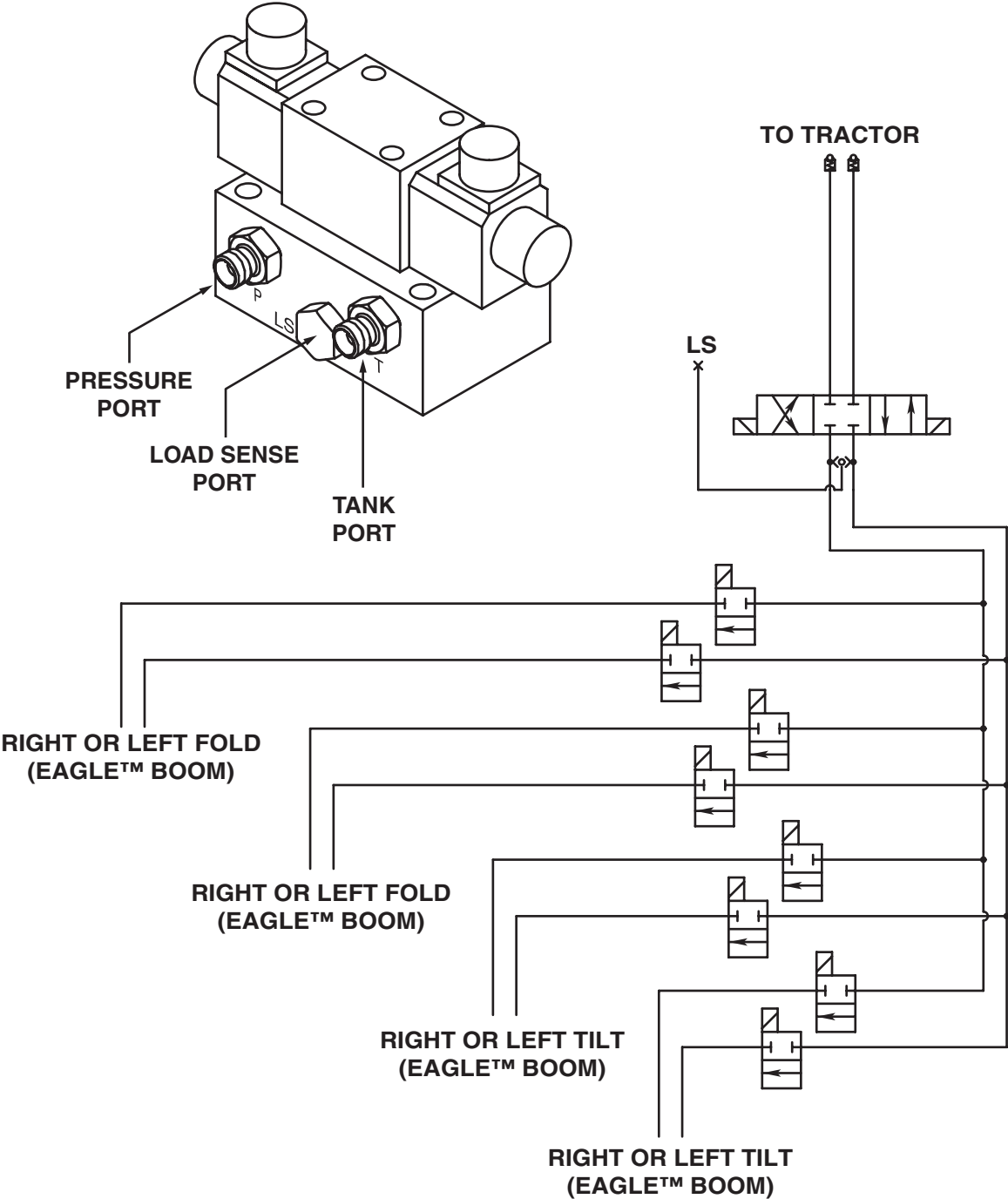

# WARRANTY POLICY AND CONDITIONS

---

HARDI® INC. , 1500 West 76th Street, Davenport, Iowa, USA; 8550 W. Roosevelt Avenue, Visalia, California, USA and 290 Sovereign Road, London, Ontario, Canada hereinafter called "HARDI®", offers the following limited warranty in accordance with the provisions below to each original retail purchaser of HARDI® new equipment of its own manufacturer, from an authorized HARDI® dealer, that such equipment is at the time of delivery to such purchaser, free from defects in material and workmanship and that such equipment will be warranted for a period of one year from the date of delivery to the end user providing the machine is used and serviced in accordance with the recommendations in the Operator's Manual and is operated under normal farm conditions.

1. This limited warranty is subject to the following exceptions:
  - a)Parts of the machine not manufactured by HARDI®, (i.e. engines, tires, tubes, electronic controls, and other components or trade accessories, etc.) are not covered by this warranty but are subject to the warranty of the original manufacturer. Any claim falling into this category will be taken up with the manufacturer concerned.
  - b)This warranty will be withdrawn if any equipment has been used for purposes other than for which it was intended or if it has been misused, neglected, or damaged by accident, let out on hire or furnished by a rental agency. Nor can claims be accepted if parts other than those manufactured by HARDI® have been incorporated in any of our equipment. Further, HARDI® shall not be responsible for damage in transit or handling by any common carrier and under no circumstances within or without the warranty period will HARDI® be liable for damages of loss of use, or damages resulting from delay or any consequential damage.
2. We cannot be held responsible for loss of livestock, loss of crops, loss because of delays in harvesting or any expense or loss incurred for labor, supplies, substitute machinery, rental for any other reason, or for injuries either to the owner or to a third party, nor can we be called upon to be responsible for labor charges, other than originally agreed, incurred in the removal or replacement of components.
3. The customer will be responsible for and bear the costs of:
  - a)Normal maintenance such as greasing, maintenance of oil levels, minor adjustments, etc.
  - b)Transportation of any HARDI® product to and from where the warranty work is performed.
  - c)Dealer travel time to and from the machine or to deliver and return the machine from the service workshop for repair.
  - d)Dealer traveling costs.
4. Parts defined as normal wearing items, (i.e. tires and V-belts) are not in any way covered under this warranty.
5. This warranty will not apply to any product which is altered or modified without the express written permission of HARDI® and/or repaired by anyone other than an Authorized Service Dealer.
6. Warranty is dependent upon the strict observance by the purchaser of the following provisions:
  - a)That this warranty may not be assigned or transferred to anyone.
  - b)That the Warranty Registration Certificate has been correctly completed by dealer and purchaser with their names and addresses, dated, signed and returned to the appropriate address as given on the Warranty Registration Certificate.
  - c)That all safety instructions in the operator's manual shall be followed and all safety guards regularly inspected and replaced where necessary.
7. No warranty is given on second-hand products and none is to be implied.

# WARRANTY POLICY AND CONDITIONS

---

8. Subject to the following terms, conditions and contributions, HARDI® extends the warranty on polyethylene tanks (excluding fittings, lids and gaskets) to FIVE YEARS. To qualify for this extended warranty, the tank must be drained and flushed with fresh water after each day of use. HARDI®'s liability is limited to replacement of the tank, FOB our plant at no cost to the purchaser during the first twelve months; at 20% of the then current price during the second year ; at 40% during the third year ; at 60% during the fourth year; and at 80% during the fifth year. This five year extended warranty is subject, in each instance, to the tank being inspected and approved for replacement or repair by HARDI® personnel before HARDI® will accept any liability hereunder.
9. Subject to the following terms, conditions, contributions, HARDI® extends the warranty on HARDI® diaphragm pumps (excluding wearing parts such as diaphragms, valves, etc.) to FIVE YEARS. To qualify for this extended warranty, the pump must be drained and flushed with fresh water after each day of use. HARDI®'s liability is limited to replacement of defective parts, FOB our plant at no cost to the to the purchaser during the first twelve months after date of purchase, at 20% of the then current retail price during the second year ; at 40% during the third year ; at 60% during the fourth year ; and at 80% during the fifth year. This five year extended warranty is subject, in each instance, to the pump being inspected and approved for replacement or repair by HARDI® personnel before HARDI® will accept any liability hereunder.
10. HARDI® reserves the right to incorporate any change in design in its products without obligation to make such changes on units previously manufactured.
11. The judgement of HARDI® in all cases of claims under this warranty shall be final and conclusive and the purchaser agrees to accept its decisions on all questions as to defect and to the exchange of any part or parts.
12. No employee or representative is authorized to change this warranty in any way or grant any other warranty unless such change is made in writing and signed by an officer of HARDI® at it's head office.
13. Any warranty work performed which will exceed \$400.00 MUST be approved IN ADVANCE by the Service Manager.
14. Any pump replacement must be approved in advance by the Service Manager.
15. Claims under this policy must be filed with HARDI® within thirty (30) days of work performed or warranty shall be void.
16. Parts requested must be returned prepaid within thirty (30) days for warranty settlement.
17. Warranty claims must be COMPLETELY filled out properly or will be returned.

## DISCLAIMER OF FURTHER WARRANTY

THERE ARE NO WARRANTIES, EXPRESSED OR IMPLIED, EXCEPT AS SET FORTH ABOVE.  
THERE ARE NO WARRANTIES WHICH EXTEND BEYOND THE DESCRIPTION OF THE PRODUCT CONTAINED HEREIN. IN NO EVENT SHALL THE COMPANY BE LIABLE FOR INDIRECT, SPECIAL OR CONSEQUENTIAL DAMAGES (SUCH AS LOSS OF ANTICIPATED PROFITS) IN CONNECTION WITH THE RETAIL PURCHASER'S USE OF THE PRODUCT.



