



The Sprayer

# *Operator's Manual*

**PRESIDIO**

**2700**

**Instruction book**

67023203 - Version 1.01

US - 11.2015





# **PRESIDIO**

## **2700**

### **Instruction book**

67023203 - Version 1.01

US - 11.2015

HARDI® reserves the right to make changes in design, material, or specification without notice thereof.  
HARDI® and other product names are registered trademarks of HARDI® Inc. in the U.S. and in other countries.



---

<b>1 - Welcome</b>	
<b>Welcome letter</b> .....	<b>9</b>
<b>2 - Safety notes</b>	
<b>Operator safety</b> .....	<b>11</b>
Symbols .....	11
General info .....	11
Important guidelines .....	11
Operator's skill .....	12
Driving on public roads .....	12
Driving in fields .....	12
Lights, working at night .....	12
Recommendations to users of crop protection chemicals .....	13
Personal safety equipment .....	13
Safety decals .....	14
Mandatory .....	14
Prohibited .....	14
Danger .....	15
<b>Local poison information center</b> .....	<b>16</b>
<b>3 - Description</b>	
<b>General information</b> .....	<b>17</b>
General View .....	17
Sprayer use .....	17
Sprayer identification plates .....	17
Frame .....	17
Tanks .....	17
<b>Liquid system</b> .....	<b>18</b>
General information - valve system .....	18
Pump .....	18
Valves and symbols .....	18
Suction valve .....	18
Pressure valve .....	18
Diagram - Liquid system with optional extras .....	19
External electrical controls .....	20
TurboFiller .....	20
Filters .....	21
CycloneFilter .....	21

# Table of Contents

---

<b>Cabin .....</b>	<b>22</b>
Access to the cab .....	22
Emergency Exit .....	22
Operator's compartment .....	22
Operator's seat controls .....	22
Instrument panel area .....	23
Left instrument panel .....	23
Right instrument panel .....	23
Steering column switches .....	23
Deutz Display .....	24
Travel lever .....	24
Engine and travel speed controls .....	24
HARDI® spray center .....	25
Multifunction Grip Handle .....	25
Overhead switches .....	26
Right side cabin ceiling .....	26
Rear right cabin .....	26
Behind operator's seat .....	27
Fuse access panels .....	27
Audio system .....	28
Defroster vents .....	28
Air vents .....	28
Cab air filter .....	28
Sun shield .....	29
<b>Boom .....</b>	<b>30</b>
Boom Operator's Manual .....	30
<b>Equipment .....</b>	<b>31</b>
Platform .....	31
Tank level indicator .....	31
Remote pressure gauge .....	31
<b>4 - Sprayer setup</b>	
<b>Starting and use .....</b>	<b>33</b>
Unloading the sprayer from the truck .....	33
Check engine .....	33
Filling the fuel tank .....	33
<b>Transport .....</b>	<b>34</b>
Transport rests .....	34
<b>Track width .....</b>	<b>35</b>
Altering the track width .....	35
Altering the track width on the rear axle .....	35
Altering the track width on the front axle .....	35
Adjusting front axle toe-in .....	36
<b>Boom .....</b>	<b>37</b>
Check boom operator's manual .....	37

## 5 - Sprayer setup

<b>Starting the PRESIDO .....</b>	<b>39</b>
General information .....	39
Preliminary operations .....	39
Starting the engine .....	40
Engine panel .....	40
Navigation keys .....	40
Using the soft keys .....	41
Setting Display Contrast and Lighting .....	41
The Main Engine Display .....	41
The Quad Display .....	43
The Graph Display .....	43
The Quad and Graph Parameters .....	44
The Alarm Display Screen .....	45
Pop-up Messages and Warnings .....	45
Secure Settings - PIN .....	45
Incorrect PIN entry .....	46
Entering the Screen by accident .....	46
PIN Entry ON/OFF .....	46
Changing the PIN .....	46
Configuration Menu .....	47
<b>Driving .....</b>	<b>48</b>
Driving in automotive mode (road) .....	48
Stopping the vehicle in road mode .....	49
Driving in normal mode (field) .....	50
Limiting the speed (field mode only) .....	51
Constant speed (field mode only) .....	51
Hydraulic all wheel lock .....	51
Stopping the vehicle in field mode .....	52
Shutting off the engine .....	53
Static braking .....	53
<b>Operating the cab controls .....</b>	<b>54</b>
Steering column adjustment .....	54
Operator seat adjustment .....	54
Turn signal/light switch .....	55
Overhead cab light .....	55
Side mirror controls .....	56
Air conditioning and heating control panel .....	57
<b>Boom .....</b>	<b>58</b>
Rear transport lock .....	58
Safety info .....	58
Operating the boom .....	58
<b>Liquid system .....</b>	<b>59</b>
Filling/washing location requirements .....	59
Filling of water .....	59
Filling of main tank .....	59
Filling of rinse tank .....	60
Filling of clean water tank .....	60
Agitation .....	61
Agitation before re-starting spraying .....	61
Parking the sprayer .....	62
Safety precautions - crop protection chemicals .....	62
Chemical Filling .....	62
Filling chemicals via the TurboFiller .....	63
Rinsing TurboFiller .....	63
Prepare sprayer for Spraying .....	63
Spraying controls from the cab .....	64
Electrically controlled end nozzle (optional) .....	64
Foam marker controls (optional) .....	64

# Table of Contents

---

<b>Cleaning .....</b>	<b>65</b>
General information .....	65
Guidelines .....	65
Use of rinse tank and rinsing nozzles .....	65
A. Full internal rinsing .....	66
B. Flushing spraying circuit without diluting main tank contents .....	67
C: Full internal cleaning (Soak wash) .....	68
Use of detergents .....	69
Technical residue .....	69
Cleaning and maintenance of filters .....	69
<b>6 - Maintenance</b>	
<b>Lubrication .....</b>	<b>71</b>
General information .....	71
Table of recommended lubricants .....	71
<b>Service and Maintenance intervals .....</b>	<b>72</b>
Boom and engine manuals .....	72
Service and maintenance chart .....	72
Service and maintenance chart (continued) .....	73
<b>Presidio maintenance .....</b>	<b>74</b>
Tighten wheel nuts .....	74
CycloneFilter maintenance .....	74
Hydraulic oil level .....	75
Filling the hydraulic oil reservoir .....	75
Hydraulic oil filter replacement .....	75
Draining the hydraulic reservoir .....	76
Hydraulic hoses .....	76
Air reservoir .....	76
Pneumatic suspension .....	76
Cleaning the radiator .....	77
Hood side panels .....	77
Activated carbon filters (cabin) .....	78
Checking the efficiency of the brakes .....	78
Checking the efficiency of the parking brake .....	78
Towing the vehicle .....	79
Maintaining reduction gear of rear wheel motor .....	80
Maintaining boom paralift .....	80
Greasing the frame .....	81
<b>Engine maintenance .....</b>	<b>82</b>
Before starting every day .....	82
Periodic engine maintenance .....	82
Engine oil level .....	82
Coolant level .....	83
Engine air filter maintenance .....	84
Water separator (fuel system) .....	84
Replacing the water separator element .....	85
Fuel system priming .....	85
Replacing the fuel filters .....	85
Bleed fuel tank .....	86
Engine oil and filter change .....	86



# Table of Contents

---

<b>Occasional maintenance .....</b>	<b>87</b>
General information .....	87
Air nozzle .....	87
Air regulator on run dry fluid pump .....	87
HARDI® run dry fluid pump .....	87
Generator and battery .....	88
Check the electrolyte level of the battery .....	88
Cone check/replacement for EFC distribution valve .....	88
Level indicator adjustment .....	89
Level indicator wire replacement .....	89
Drain valve seal replacement .....	89
Adjustment of 3-way-valves .....	90
Filling filter removal/cleaning .....	90
Replacing the brake discs .....	90
Brake accumulator .....	90
<b>Off-season storage .....</b>	<b>91</b>
Off-season storage program .....	91
Preparing the sprayer for use after storage .....	91
<b>7 - Fault finding</b>	
Liquid system .....	93
<b>Electrical incidents .....</b>	<b>94</b>
Fuses for circuit board EA0560 .....	94
Fuses for circuit board EA0554 .....	95
Fuses for circuit board EA0563 .....	96
<b>8 - Technical Specifications</b>	
<b>Specifications .....</b>	<b>97</b>
Dimensions .....	97
Weight .....	98
Tire pressures .....	<b>98</b>
<b>9 - Warranty</b>	
<b>Warranty policy and conditions .....</b>	<b>99</b>
.....	<b>100</b>
<b>Index</b>	
<b>Index .....</b>	<b>101</b>

---

## Table of Contents

---

---

## Welcome letter

---



Dear New HARDI® Owner,

Thank you for purchasing your new HARDI® product and welcome to the ever-increasing family of proud HARDI® owners.

HARDI® is the leading sprayer company in offering growers strong, reliable products made for the widest range of applications worldwide. Quality, reliability, and resale value make the HARDI® product line the preferred product line of customers both in North America as well as worldwide. Our guiding principle is to provide the highest level of customer satisfaction and long term value in the marketplace today. We have developed a very high level of customer loyalty in the marketplace which we are very proud of and strive every day to maintain and to continue to grow.

HARDI® is your specialist in spraying and we spend all of our time and keep all of our focus on spraying. We do not share our resources between other types of products or compromise on anything in providing the best quality sprayers to the market today. We can provide the latest in technology with our products if desired, or allow them to operate with the technology that you already use on other products in most cases. You get to decide that, and what best suits your needs. We feel that you, our customer, are the best suited to answer that question for your operation. Either way, you decide, and we will try and help make it happen for you.

Our broad spectrum of product offerings, from the ruggedly simple models we build to our highly sophisticated models, the built-in HARDI® strength and reliability ensures a low cost of ownership. HARDI® sprayers are all based on a functional design concept of being as simple to operate as possible and to meet our customers' requirements for all their application needs.

Please take the time to thoroughly read the Operator's Manual before using your equipment. You will find many helpful hints as well as important safety and operation information.

Some of the features on your HARDI® sprayer were suggested by growers. There is no substitute for "on farm" experience and we invite your comments and suggestions. If any portion of this instruction book remains unclear after reading it, contact your HARDI® dealer or service personnel for further explanation before using the equipment.

**For Product, Service or Warranty Information please contact your local HARDI® dealer.**

- Please use the HARDI® Customer Service number: 1-866-770-7063

- Or send your email to [CUSTSERV@hardi-us.com](mailto:CUSTSERV@hardi-us.com)

**HARDI® NORTH AMERICA INC.**

**Visit us online at: [www.hardi-us.com](http://www.hardi-us.com)**

1500 West 76th St.  
Davenport, Iowa 52806  
Phone: (563) 386-1730  
Fax: (563) 386-1280

Sincerely,

A handwritten signature in black ink, appearing to read "Wayne Buchberger". The signature is fluid and cursive, with a long horizontal stroke extending to the right.

Wayne Buchberger

President



### Operator safety

---

#### Symbols

These symbols are used throughout the book to designate where the reader needs to pay extra attention.



This symbol means DANGER. Be very alert as your safety is involved!



This symbol means WARNING. Be alert as your safety can be involved!



This symbol means ATTENTION. This guides you to better, easier and safer operation of your sprayer!



This symbol means NOTE.

---

#### General info

Before using the sprayer, read the following recommendations and safety instructions.

- Read this instruction book carefully before using the equipment. It is equally important that other operators of this equipment also read this book.
  - If any portion of this instruction book remains unclear after reading it, contact your HARDI® dealer for further explanation before using the equipment.
  - Local law may demand that the operator is certified to use spray equipment. Adhere to the law.
  - The driver's seat is the intended working place during operation.
  - Wear protective clothing. Clothing may differ according to the plant protection chemicals used. Comply to any applicable local legislation.
  - After spraying, the operator should wash and change his clothes.
  - Rinse and wash equipment after use and before servicing. Wash tools if they have become contaminated.
  - Do not eat, drink or smoke during the use and maintenance of your sprayer.
  - In case of poisoning, immediately seek medical advice. Remember to identify chemicals used. Follow instructions indicated on the label(s) of the products used.
  - Never service or repair the equipment while it is operating.
  - Replace all safety devices or shields immediately after servicing.
  - Do not go under the machine unless it is secured. The boom is secure when placed in the transport brackets with rear transport lock engaged (See "Rear transport lock" on page 58).
  - Do not attempt to enter the tank.
  - Keep children away from the sprayer.
- 

#### Important guidelines

- Comply with all recommendations for installation, carrying out adjustments, maintenance and repair contained in this instruction book.
  - Use only original spare parts and accessories conforming to the manufacturer's recommendations.
  - Do not modify or have your machine and its accessories modified by someone else (mechanical, electrical, hydraulic and pneumatic characteristics) and, more generally, the parts of the machine affecting user safety, without first requesting written agreement from the manufacturer.
  - Failure to respect these rules may make your machine dangerous. In the event of damage or injury, HARDI® shall not be held liable in any way.
-

## 2 - Safety notes

---

### Operator's skill

The machine should be used and maintained by people who are aware of its special use and safety characteristics. Before using your machine, familiarize yourself with all the commands. When working, it will be too late to do so. Ensure that you have the skills required for protecting crops and the environment, and for handling and spraying plant protection chemicals.

---

### Driving on public roads

When driving on public roads, obey all traffic regulations. Pay particular attention to those regarding mandatory equipment such as lights, indicators, hazard lights, etc.

You should be aware of the vehicle's size and weight, particularly the overall width and height.



**WARNING!** You must in all circumstances adapt your driving on the road, particularly by reducing your speed during turns or when road conditions demand. Also reduce speed when meeting or being passed by another vehicle.

---

### Driving in fields

Be very careful to avoid the risk of overturning when driving at speeds greater than 9 mph (15 km/h) or when driving on a slope.

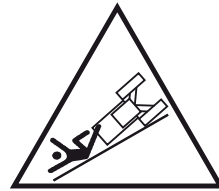

**ATTENTION!** As a general rule:

- Adapt your speed and driving to suit the terrain you are driving on. Be aware and take care!
- Slow down when driving on uneven terrain as the sprayer may become unbalanced and overturn.
- No persons are allowed in the operational area of the sprayer. Take care not to harm people or surroundings when maneuvering the sprayer, especially while backing up.
- In all circumstances and particularly on uneven and sloping terrain, drive the machine at a low speed, especially on curves and avoid sudden changes of direction.
- Do not brake or accelerate suddenly when going up or down a slope, bearing in mind the variable volume of liquid in the sprayer tank.



**DANGER!** Boom maneuvers should be carried out with the sprayer stationary and on flat ground. Ensure that there are no obstacles nearby (electrical lines, people, poles etc.).

---

### Lights, working at night

If there is insufficient light for working at night, the spraying boom should be equipped with boom lights. For more information on this equipment, contact your HARDI® dealer.

### Recommendations to users of crop protection chemicals

This sprayer has been designed and manufactured by HARDI® for the application of crop protection chemicals. For your safety and the proper functioning of the sprayer, it is important to read and understand all instruction books delivered with this sprayer.

It is also the sole responsibility of the operator to strictly comply with all recommendations given by the manufacturers of all crop protection chemicals used with this sprayer.

In particular, it is strongly recommended that any operator of this sprayer:

- Carefully read the label(s) of the manufacturer(s) of the treatment products used with this sprayer and follow the instructions given (measuring, personal protective equipment, etc.);
- Mix only products whose compatibility was expressly recognized by the manufacturer(s) of the crop protection chemicals being mixed;
- Avoid introducing air while filling the tank to prevent the formation of foam and cause problems with overflow;
- Follow the manufacturer(s) instructions and warnings for all crop protection chemicals regarding proper storage, processing and keeping chemicals out of the reach of children and animals;
- Observe all precautions relating to the disposal/recycling of packaging, in accordance with the recommendations of the manufacturer(s) of the products used;
- Contact the manufacturer(s) of the plant protection product (or their representative) if any doubt remains after reading the label(s) of their product(s).

---

### Personal safety equipment

Depending on which type of chemical is used, some or all of the following protective clothing and equipment will be required:

1. Ear muffs
2. Safety goggles or face shield
3. Respirator
4. Chemical resistant coveralls
5. Chemical resistant gloves
6. Chemical resistant boots

### Contaminated clothing

Contaminated clothing should be removed and safely stored and laundered. Do not contaminate the inside of the cab with soiled clothing.



## 2 - Safety notes

---

### Safety decals

It is important that the safety decals remain in place and in good condition. The decals will draw your attention to all the possible dangers and refer to this instruction manual.

Replace any safety decals that are missing, illegible or damaged.

Clean off any mud or dirt that makes the safety decals illegible.

---

### Mandatory

#### Read manual

- Read the operator's manual before operating machine.
- Regularly consult manual for maintenance schedule, instructions, etc.



#### Remove key

- Remove the ignition key before leaving the cab to perform maintenance.
- Consult operator's manual before performing maintenance.



#### Tire maintenance

- The wheel nuts must be re-torqued after the first 2 hours of operation. Then periodically check that the tires are properly inflated.



### Prohibited

#### Speed limit

- Maximum speed limit while operating the sprayer.
- Extra care must be taken on hills and when cornering.



#### Engine start

- Never attempt to start engine while outside the cab.



#### Do not climb

- Do not climb on or off machine.
- Always use ladder and working platform to access the machine.



#### Do not drink

- Water from the clean water tank is for hand washing, cleaning of clogged nozzles, etc. This water must never be used for drinking.

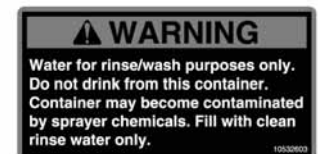



### Danger

#### Overhead wires

- Take care when operating near wires to prevent entanglement or electrocution.



#### Fluids under pressure

- Shut down the engine and relieve pressure before performing maintenance.

#### Danger overhead

- Do not enter paralift area or stand under boom.

#### Danger from hot surface

- Risk of burns.

#### Danger from crushing

- Risk of crushing.

#### Danger from crushing

- Risk of crushing hand.

#### Danger from radiator

- Risk of injury from fan blades.
- Risk of burns.

#### Danger from wheel

- Risk of being crushed by wheel.

#### Danger from machine

- Stay a safe distance from the machine.

#### Danger of toppling over on hillside or slope

- Drive with extreme caution.
- Widen axle track width to minimize risk.



## 2 - Safety notes

---

### Local poison information center



If you live anywhere in the United States, the following toll free number will connect you to your Local Poison Information Center.

PHONE NO. 1 - 800 - 222 - 1222



If you live outside the United States, find the number for the poison control center in your phone book and write it in the space below:

PHONE NO. \_\_\_\_\_ - \_\_\_\_\_ - \_\_\_\_\_



Keep a list, in the space provided below, of all the chemicals that you have in use.

1. \_\_\_\_\_

2. \_\_\_\_\_

3. \_\_\_\_\_

4. \_\_\_\_\_

5. \_\_\_\_\_

6. \_\_\_\_\_

7. \_\_\_\_\_

8. \_\_\_\_\_

9. \_\_\_\_\_

10. \_\_\_\_\_

---

### General information

---

#### General View

The PRESIDIO is divided into 3 zones: a Clean zone, a Working zone and a Spraying zone, referring to the level of possible chemical contamination. The functions and features are listed by zones below. Please note that some of the features are optional equipment.

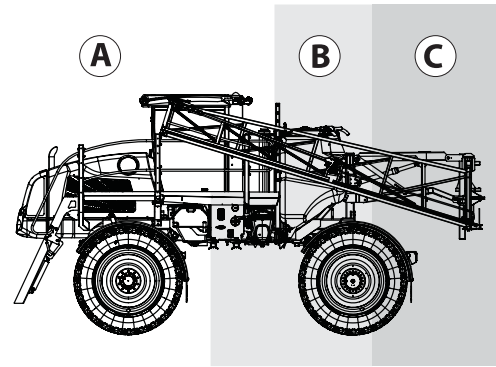

A. Clean Zone	Engine Cabin Valve for hand washing Access to Main tank
B. Working Zone	Tank level indicator Sprayer fluid controls Quick Fill couplers TurboFiller
C. Spraying Zone	Boom lift, up/down Boom Nozzles Mudguards Suspension

---

#### Sprayer use

The HARDI® sprayer is for the application of crop protection chemicals and liquid fertilizers. The equipment must only be used for this purpose. It is not allowable to use the sprayer for other purposes. If no local law demands that the operator must be certified to use spray equipment, it is strongly recommended to be trained in correct plant protection and in safe handling of plant protection chemicals to avoid unnecessary risk for persons and the environment when doing your spray job.

---

#### Sprayer identification plates



---

#### Frame

The PRESIDIO frame is built to offer the best possible performance, cost efficiency and ease of operation under a broad range of working conditions. In order to maintain these conditions and protect the correct, problem-free operation of the machine, it is important to perform the operations described in the "MAINTENANCE" section at the recommended frequencies.

---

#### Tanks

The main tank is made of impact-proof, UV-resistant and chemical resistant polyethylene. It has a purposeful design with no sharp corners for easy cleaning. Nominal content: 700 gallons (2700 liters). A large, easy to read tank level indicator is placed beside the platform and is visible from the cabin. The filling hole is placed so it can be accessed from the platform. The PRESIDIO is standard equipped with a 70 gallon (265 liter) rinse tank, and a 4 gallon (15 liter) clean water tank (hand washing tank).

### 3 - Description

#### Liquid system

##### General information - valve system

All of the spray functions are operated via centrally located valves with color coded pictorial symbols for easy operation. The fluid system is located in the Working Zone on the sprayer's left side.

##### Pump

The PRESIDIO uses the HARDI® 650 WetSeal run dry centrifugal pump.

##### Valves and symbols

The valves are identified by colored symbols according to their function. They correspond to the different possible functions of the valves, thus facilitating their use. A function is activated by turning the handle towards the desired function.

##### Suction valve

###### Suction valve = blue symbols

Turn the handle towards the symbol for the desired function



Suction from main tank



Suction from rinse tank

##### Pressure valve

###### Pressure valve = green symbols

Turn the handle towards the symbol for the desired function

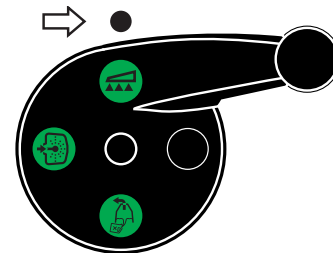

Boom spraying



Rinse nozzle



TurboFiller

Diagram - Liquid system with optional extras

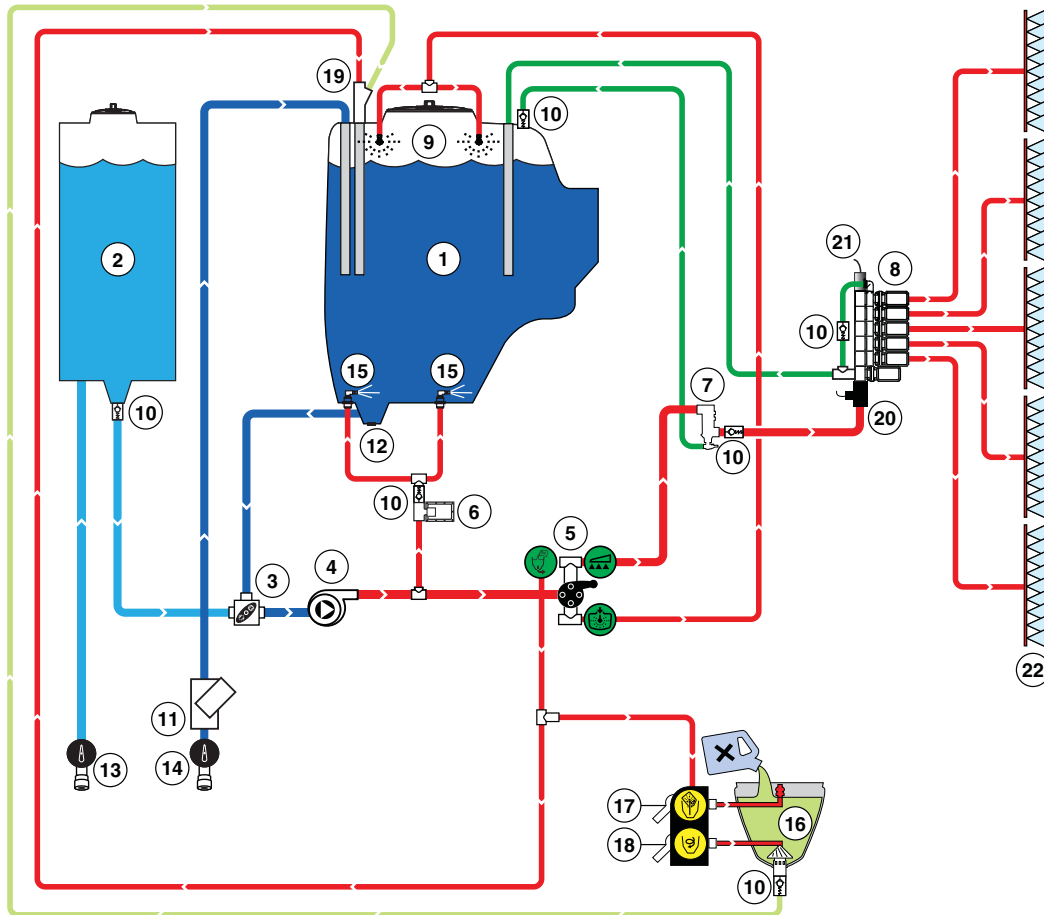

- |                               |                              |
|-------------------------------|------------------------------|
| 1. Main Tank                  | 12. Tank Drain               |
| 2. Rinse Tank                 | 13. Rinse Tank Quick Fill    |
| 3. Suction Valve              | 14. Main Tank Quick Fill     |
| 4. Pump                       | 15. Agitation Nozzles        |
| 5. Pressure Valve             | 16. HARDI® TurboFiller       |
| 6. Agitation Valve (electric) | 17. Chemical Container Rinse |
| 7. CycloneFilter              | 18. Chemical Mix             |
| 8. EFC Distribution Valves    | 19. Venturi                  |
| 9. Rinse Nozzles              | 20. Flow Meter               |
| 10. One Way Valves            | 21. Pressure sensor          |
| 11. Main Tank Fill Filter     | 22. Spray boom               |

## 3 - Description

### External electrical controls

A panel equipped with electrical switches provides external control of the spray pump, agitation, spray nozzles and engine speed.

1. Engine speed control
2. Pump on/off switch
3. Emergency engine stop switch
4. Spray nozzles on/off switch
5. Agitation Max/Min switch

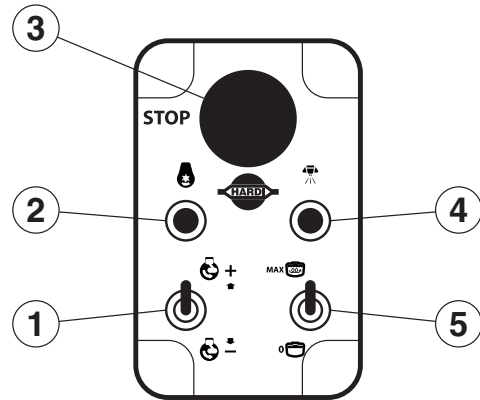

### TurboFiller

#### TurboFiller = yellow symbols

The TurboFiller is located in the Working Zone on the sprayer's left side. The TurboFiller is held in its storage position by an over-center spring. For operation, grab the handle (1) and pull down on the TurboFiller until it stops at its operating position.

After use, the TurboFiller is retracted by pulling the handle (1) back up until the over-center spring holds it in the storage position.

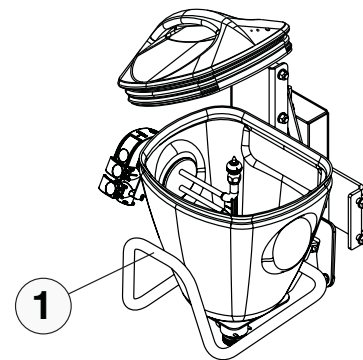

#### TurboDeflector valve

This TurboDeflector valve activates the vortex flushing of the TurboFiller. The valve is the bottom valve located to the left side of the TurboFiller and is activated in two ways. Push the valve lever down to get a quick flush in the hopper. Lift the lever to lock it in the open position for continuous liquid rotation in the hopper.

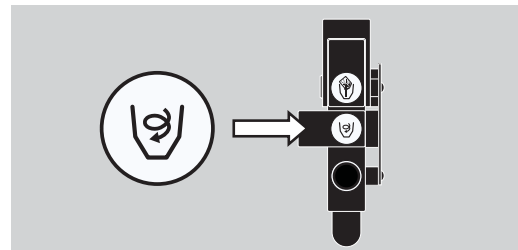

#### Chemical container cleaning lever

The upper lever located to the left of TurboFiller is used for two purposes:

When TurboFiller lid is open: For cleaning empty containers. Put container over the rotating rinsing nozzle in the middle of the TurboFiller to rinse inside of the container.

When TurboFiller lid is closed: Use the Chemical Container Cleaning lever to rinse the hopper after filling of chemicals has ended.

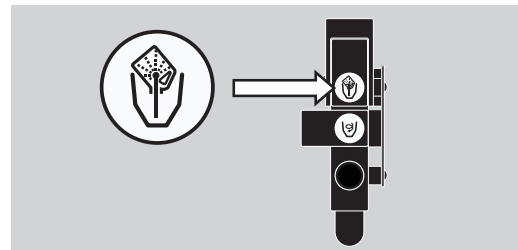

**DANGER!** Do not press lever unless the multi-hole nozzle is covered by a container or the TurboFiller lid is closed to avoid spray liquid hitting the operator.

### Filters

A Cyclone pressure filter is fitted in the liquid area on the left side of the TurboFiller. It has a built in self-cleaning function.

In-line pressure filters are fitted at each section.

All filters should always be in use and their function checked regularly. Pay attention to the correct combination of filter and mesh size. The mesh size should always be less than the average of the nozzles in use.

### CycloneFilter

With the CycloneFilter, any impurities in the spray liquid will by-pass the filter and be recirculated back to the tank via the return flow.

Function diagram

1. Filter lid
2. From pump
3. To boom
4. To remote return valve



Note: Remote return valve is located underneath the CycloneFilter behind the Liquid valves.

Remote return valve

5. From CycloneFilter
6. Return to tank
7. Remote return valve

Valve (7) has three positions marked with small dots on the lever:

- A. This position (Marked with 1 dot): There is no return flow. Position is used when flushing the boom if there is spray liquid in the main tank. Also used when high spraying volume is required.
- B. This position (Marked with 2 dots): Normal spraying position. With return flow to prevent clogging the filter when spraying. This position is used when flushing the boom if the main tank is empty.
- C. This position (Marked with 3 dots): Flushing position, which is used if filter is clogged. Lift and hold the lever to use this position which largely increases return flow and flushes the filter. The pressure valve must be set to "Boom spraying".

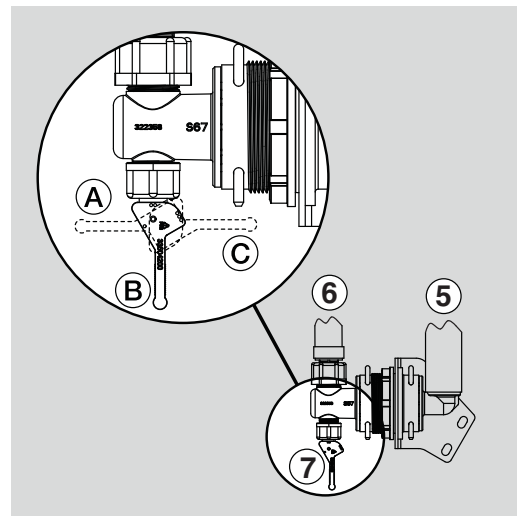
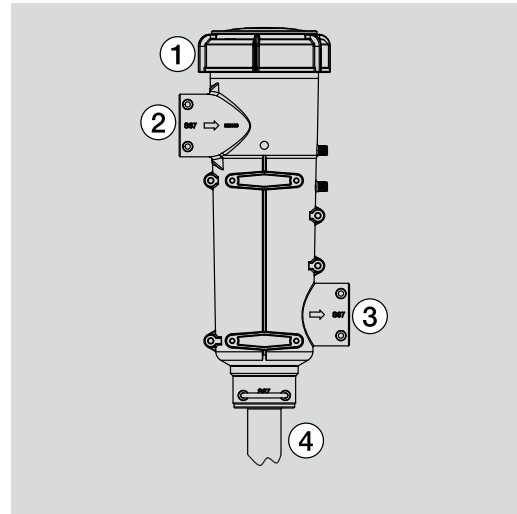

**DANGER!** The CycloneFilter must not be opened when the pressure valve is set to "Boom spraying". Otherwise, contaminated spray liquid can escape and drain from the tank.



**ATTENTION!** Use of position (C) is no guarantee for a clean filter. Always regularly do a visual inspection and cleaning of the filter. If needed, see "CycloneFilter maintenance" on page 74.

## 3 - Description

### Cabin

#### Access to the cab

The cab is accessed by the front ladder and working platform. Two sets of keys are provided for the PRESIDIO.

To open door from inside the cab, lift handle (A).



Note: The short key locks/unlocks the cab door. The long key is the ignition key.



#### Emergency Exit

In case of emergency, the window located to the right of the driver's seat, opposite the door of the cab, may be used as an emergency exit. This window is normally secured with a safety screw that is only accessible from outside the cabin at the base of the window. The screw must be removed before the window will open from the inside.

In case of emergency, use the hammer located on the rear cabin support to break glass and exit through the window frame.

If the outside safety screw has been removed, it is possible to exit the cab in the following way:

- Unlock the window by rotating the two window handles clockwise until they disengage.
- Open the window completely.
- Exit the cab.



**DANGER!** Always keep the path from the emergency exit free of any obstacles, to allow exit in case of emergency.

#### Operator's compartment

The operator station in the cab is the main work station. When the PRESIDIO is functioning, all other zones are danger zones.

When the operator leaves the cab to use the "Work Zone" under the platform:

- Stop any movement of the PRESIDIO.
- Bring the travel lever to the neutral point.
- Apply the parking brake.
- Lower the boom onto the transport bracket for storage, or to the lowest height if unfolded.

#### Operator's seat controls

1. Fore/aft cushioning lock
2. Fore/aft seat adjustment lever
3. Seat height adjustment lever
4. Seat swivel lever
5. Back rest angle adjustment lever
6. Storage compartment





## 3 - Description

### Instrument panel area

The left (A) and right (B) instrument panels on the steering column display important information about the PRESIDIO operation.

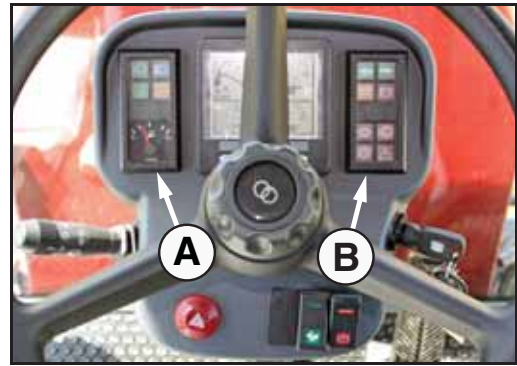

### Left instrument panel

1. Low beam headlights
2. High beam headlights
3. Parking lights
4. All wheel lock indicator
5. Fuel gauge

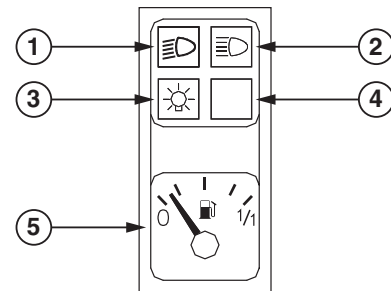

### Right instrument panel

6. Left turn signal indicator
7. Right turn signal indicator
8. Engine preheat
9. Battery charge fault
10. Oil filter clogged/transmission
11. Oil/transmission low level
12. High oil/transmission temperature
13. Fault/engine

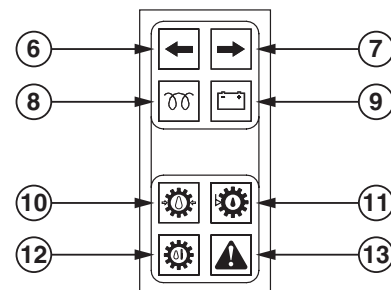

### Steering column switches

- A. Hazard light on/off switch
- B. Hazard indicator lights
- C. Speed range switch
- D. Parking brake switch
- E. Ignition switch

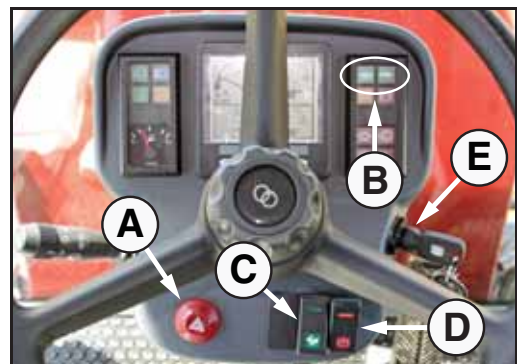

### 3 - Description

#### Deutz Display

The Deutz Display is a compact, robust panel-mountable module that enables a user to remotely request and display engine data.



There are 5 navigation keys at the bottom of the display. The middle keys (#2 - #4) are used to make the menu bar visible on the LCD.

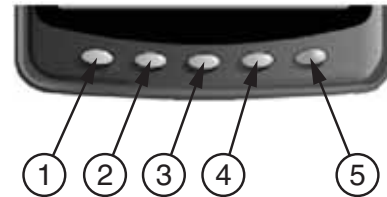

The display uses 'soft' keys to simplify the user interface. This is achieved by displaying icons in the menu bar that represent the current function of each key. Positioning the icons above the appropriate key allows each key's function to change while ensuring that the operator is always presented with a clear and unambiguous understanding of what each key press will do.



#### Travel lever

The PRESIDIO travel lever is located on the front of the arm rest (to the right of the operator seat). Moving the lever controls the direction and speed of travel. Sprayer controls are also built into the top of the handle (See "Multifunction Grip Handle" on page 25).



#### Engine and travel speed controls

The engine and travel speed control panel is located behind the travel lever on the arm rest.

- A. Constant speed indicator light
- B. Constant speed ON/OFF switch
- C. Speed limiting dial
- D. Speed limiting switch
- E. Engine speed dial (rpm)

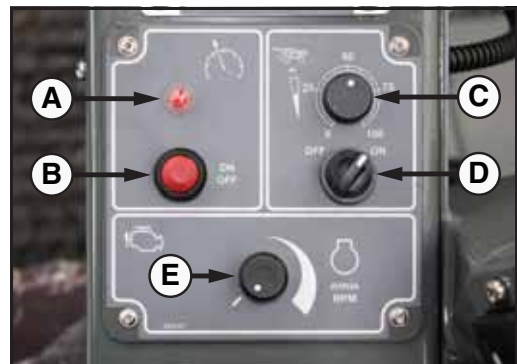

## 3 - Description

### HARDI® spray center

The HARDI® spray center is located to the right of the arm rest in the PRESIDIO cabin. It is used in combination with the Grip controls. The buttons on the console control the following functions:

1. Status LED
2. Power switch (for spray controls)
3. Spray pressure
4. Agitation switch
5. Unfold/Fold boom
6. Unfold/Fold 2nd outer section (if equipped)
7. Auto/Manual Switch for pressure regulation
8. Spray pump switch
9. Left End Nozzle ON/OFF (optional)
10. Right End Nozzle ON/OFF (optional)
11. Foam Marker Left/Right (optional)
12. Foam Marker drop interval (optional)
13. Foam Marker Inner/Outer (optional)

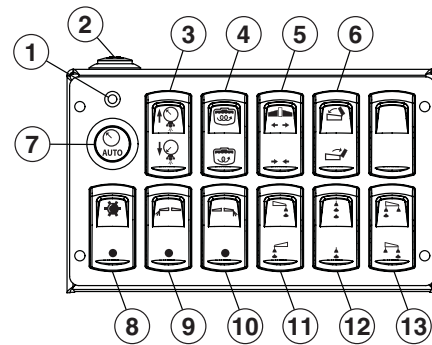

### Multifunction Grip Handle

The PRESIDIO travel lever is a multifunction Grip handle. All common functions required during normal spraying can be operated with the Grip. Also the Grip controls some optional functions.

- A. Status LED.
- B. Boom section controls (up to 13).
- C. Main ON/OFF.
- D. Tilt.
- E. Boom height.
- F. Not used.
- G. Not used.
- H. Not used.

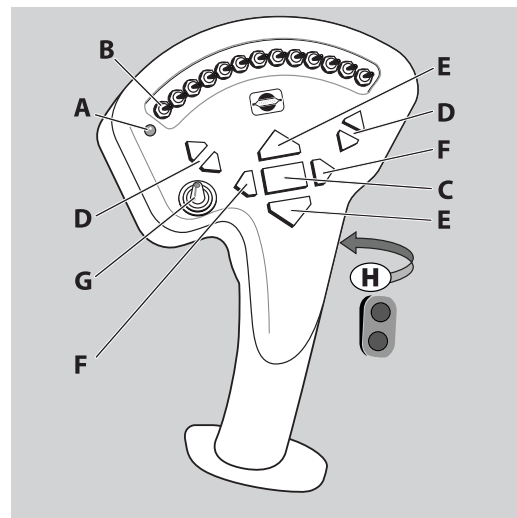

## 3 - Description

### Overhead switches

1. Windshield wiper
2. Windshield washer
3. Side mirrors defrost
4. Night reading light (red)
5. Work lights (Front)
6. Work lights (Front center cab)
7. Work lights (Front outer cab)
8. Work lights (Rear cab)
9. Boom lights (optional)
10. Warning beacon
11. Side mirrors control

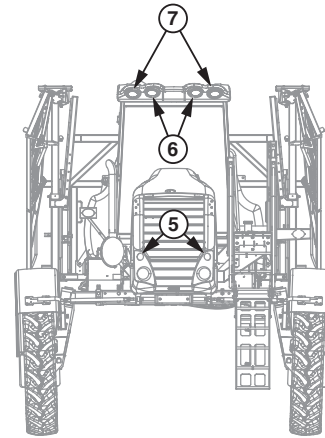
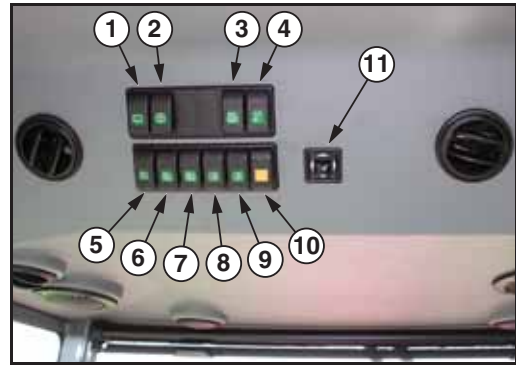

### Right side cabin ceiling

1. Radio
2. Air conditioning and heating control panel
3. Storage compartment (climate controlled)
4. Emergency hammer

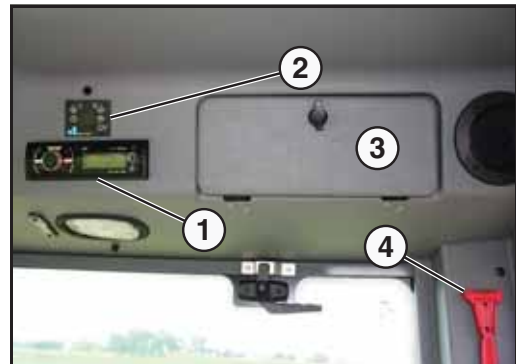

### Rear right cabin

1. 12V socket
2. Battery isolation switch
3. Engine diagnostic test point

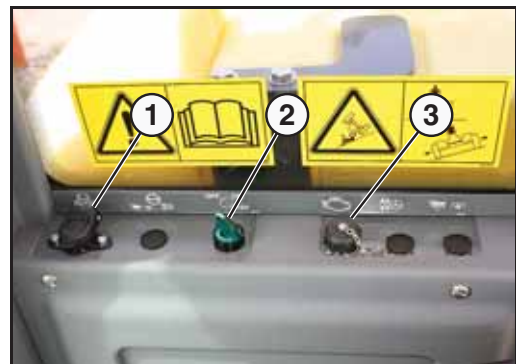

### Behind operator's seat

The back of the operator's seat holds a small storage compartment for notebooks, manuals, etc.

The windshield washer fluid tank (A) is at the rear of the cabin behind the operator's seat.



### Fuse access panels

There are two fuse access panels inside the cab to the right of the operator's seat.

Top fuse access panel with retaining bolt (A).

See ("Fuses for circuit board EA0554" on page 95) for left board fuses.

See ("Fuses for circuit board EA0563" on page 96) for right board fuses.



Bottom fuse access panel with retaining bolts (A).

See ("Fuses for circuit board EA0560" on page 94) for fuses.

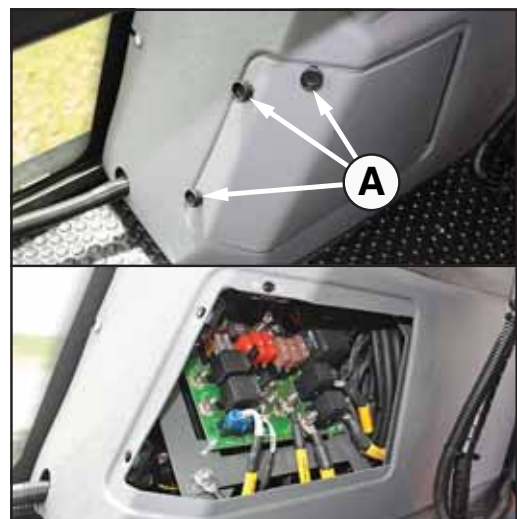



### 3 - Description

#### Audio system

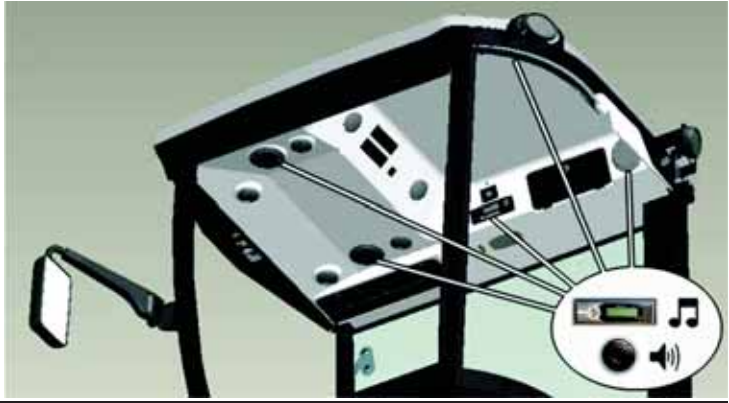

#### Defroster vents



#### Air vents



#### Cab air filter



Sun shield

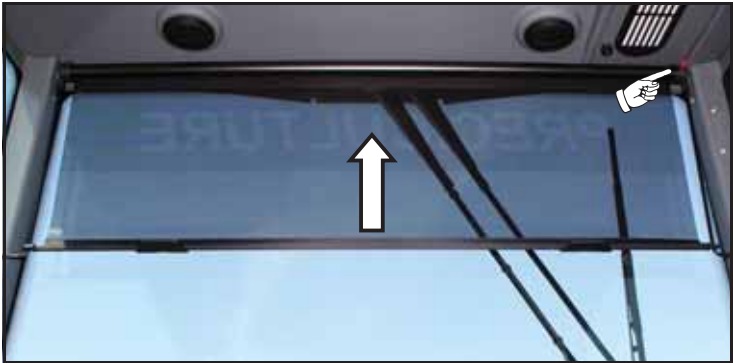

## 3 - Description

---

### Boom

---

#### Boom Operator's Manual

A separate "Boom Operator's Manual" is supplied with your sprayer and contains detailed information on boom safety, set-up, operation and maintenance.



DANGER! Important information on Safety, Operation and Maintenance specific to your boom configuration is detailed in the "Boom Operator's Manual" supplied with your sprayer. It must be read and fully understood by anyone intending to operate this equipment. Failure to do so could result in serious personal injury or death.



### Equipment

#### Platform

The cab is accessed by the front ladder (A) and platform. The ladder automatically raises for clearance when the parking brake is released. The ladder automatically lowers when the PRESIDIO is placed in park.



#### Tank level indicator

The actual fluid level in the main tank can be observed on the tank level indicator (A). The scale is displayed in US gallons (liters optional).

The level indicator is only intended as a guide for the tank level. For greater accuracy, use fill meter or optional electronic tank level sensor.

Behind the main tank scale, a level indicator hose (B) is attached to the side of the rinse tank. This is intended as a guide to make it easier to see approximately how much clean water is in the rinse tank. When the indicator ball is at the top, then the rinse tank is full.

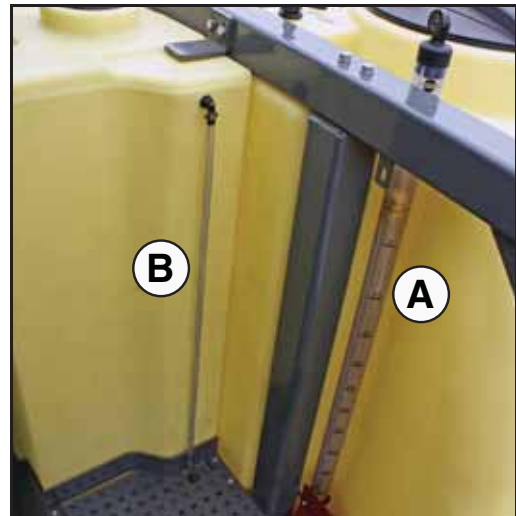

#### Remote pressure gauge

The remote pressure gauge is located above the Pressure valve in the Working Zone on the sprayer's left side. This gauge measures the working pressure in the spray manifold.

Use gauge on EFC manifold or readout from pressure transducer when calibrating sprayer.



### 3 - Description

---

---

### Starting and use

---

#### Unloading the sprayer from the truck

The machine can only be unloaded if the engine is running. In effect, the braking system is engaged unless the engine is running. To move the self-propelled sprayer, you must observe the following points:

- Turn the battery isolation switch “ON” to power the electrical circuits.
- Place the travel lever in the neutral position.
- Check that the parking brake is engaged.
- Turn the ignition key to start the engine.
- Set the speed range switch to FIELD 1 position and disengage the parking brake.
- Increase the engine rpm by rotating dial located on the PRESIDIO instrument panel. To ensure sufficient traction and braking of the self-propelled on an incline, the engine speed must be a minimum of 1500 rpm.
- Push the travel lever very slowly to move forward or backwards.
- Ensure that no one is in the unloading area.



**DANGER!** Do not attempt to unload the sprayer if you are unfamiliar with the instructions described above.

---

#### Check engine

The main elements must be verified before the first starting of the engine:

- Fuel level
- Engine oil level
- Coolant level
- Correct tightness of oil and fuel filters
- Tension on the belts

---

#### Filling the fuel tank

The fuel tank has an 85 gallon (320 L) capacity. Before filling:

- Parking brake engaged (front access ladder lowered).
- Engine stopped.
- Open access panel to fuel cap (in working platform).
- Thoroughly clean the cap to prevent the introduction of impurities into the tank. Use a funnel and filter if necessary.
- Do not smoke while filling the tank.



**DANGER!** Diesel fuel is extremely flammable. Handle with care. Do not smoke or expose fuel to open flame. It is recommended for the operator to install a fire extinguisher in a place that is easily accessible and checked regularly.



Note: Never allow the tank to empty completely to prevent the introduction of any impurities or air into the circuit.



Note: Before a prolonged shutdown, it is recommended to fill the tank to the maximum level in order to avoid any trace of condensation in the tank.



Note: Use low sulfur diesel fuel (ultra-low ULSD diesel ULSD) with a maximum of 15 ppm for the United States and Canada.

## 4 - Sprayer setup

### Transport

#### Transport rests

The transport rests are set in the lowest position for shipping. They can be moved to obtain different transport heights if desired.

To change position:

1. Check that the rear transport lock is in the storage position (See "Rear transport lock" on page 58).
2. Lift and unfold boom.
3. Lower boom completely.
4. Remove the two bolts (A) holding the left and right transport rests (B) and remove both transport rests.
5. Move left and right transport rests to new location, making sure that both sides are at the same height.
6. Tighten bolts (A). Raise and fold boom, then lower onto transport rests.
7. Measure the new folded boom height for future reference (i.e. clearance of shed doors, legal road height, etc.).

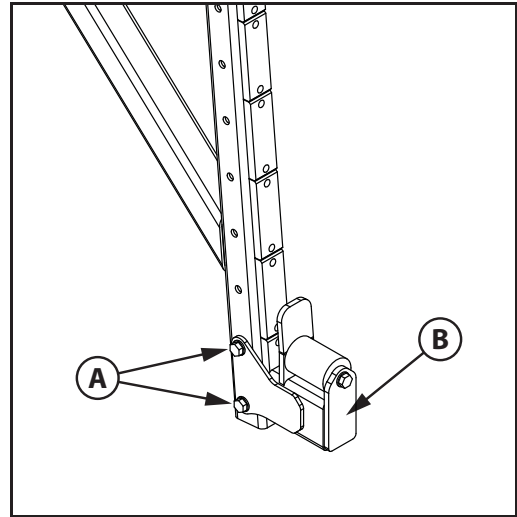

**WARNING!** The rear transport lock must be in storage position before folding/unfolding the boom. Failure to do so will cause damage to the boom.



**WARNING!** Never exceed the maximum legal transport height. Always measure the actual total height and choose settings not exceeding the legal transport height in the area to be driven.



**Note.** After changing the transport height, the rear transport lock will require a different set of holes to secure the boom.

### Track width

#### Altering the track width

The PRESIDIO is available with wide or narrow axles. Both are adjusted using the same basic procedure.

The track width of the narrow axle is infinitely adjustable from 80" to 100"

The track width of the wide axle is infinitely adjustable from 100" to 120"

Adjustment of the front axle requires tie rod adjustment/replacement. Before starting adjustment, make sure the correct tie rod is available for the desired track width. If other track width is desired, contact your HARDI® dealer for assistance.

Axle Type	250mm Tie rod	365mm Tie rod	715mm Tie rod
HARDI® part #	PR-FTPR32026	PR-FTPR32028	PR-FTPR32029
Narrow	80"	88"	X
Wide	X	X	120"



**WARNING!** Securely support the PRESIDIO during axle adjustments. Never attempt to adjust axles with liquid in the tank. Always block wheels on opposite side when adjusting axles.



**WARNING!** Place a jack under the axle and lift the wheel to remove load from the clamps before tightening the clamp bolts to the specified torque.

#### Altering the track width on the rear axle

To alter the track width on the rear axle:

1. Measure the current track width (center RH tire to center LH tire). Each side must be extended or retracted half the desired alteration.
2. The PRESIDIO engine must be shut off with the parking brake engaged during track width adjustment.
3. Place stop wedges in front of, and behind LH wheel. Jack up RH wheel and secure PRESIDIO frame.
4. Loosen the jam nuts and bolts (A) for RH axle.
5. Extend or retract axle the distance determined in step 1.
6. Tighten the clamp bolts (A) to a torque of 185 Ft/lb (250 Nm) and lock the bolts with the jam nuts.
7. Repeat the procedure on the LH wheel.
8. Confirm new track width is correct and distance from the center of tire to center of frame is equal at RH and LH sides.
9. Re-tighten bolts to a torque of 185 Ft/lb (250 Nm) after 8 hours of work.

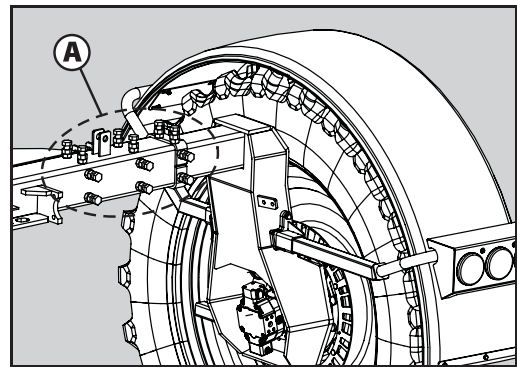

#### Altering the track width on the front axle

To alter the track width on the front axle:

10. The track width on the front axle is adjusted the same way as the rear axle except that the tie rod must be adjusted to match the desired track width.



Note: This may require a longer/shorter tie rod. See chart above.

11. Make sure steering cylinder (C) is exactly centered; same length of cylinder visible on left and right sides (D).
12. Perform steps 1 - 4 for the front axle.
13. Loosen jam nuts (E). Remove tie rod shaft (F).
14. Perform steps 5 & 6 for the front axle.

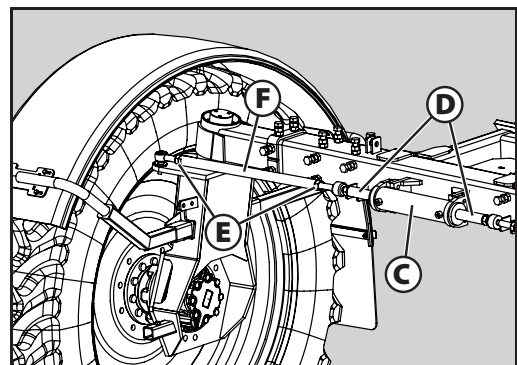

## 4 - Sprayer setup

### Adjusting front axle toe-in

15. Replace correct tie rod (F) and adjust for proper toe-in. Distance between center of front side of tires (G) needs to be  $1/2"$  (13mm) less than distance between center of rear side of tires (H).
16. Adjust tie rod (F) to achieve  $1/4"$  (6 mm) toe-in for each side.
17. Leave jam nuts (E) loose until both sides of front axle have been adjusted to desired track width.



ATTENTION! It is important that left and right tie rods are adjusted equally. Distance between center of front side of tires to center of frame must be equal on both sides.

18. Repeat the procedure on the LH wheel.
19. Confirm that toe-in is correct. Distance between center of front side of tires (G) needs to be  $1/2"$  (13mm) less than distance between center of rear side of tires (H).
20. Confirm that distance from center of front tire to center of frame is equal at RH and LH sides.
21. Tighten jam nuts (E) for RH and LH tie rods (F).
22. Re-tighten clamp bolts to 185 Ft/lb (250 Nm) after 8 hours of work.

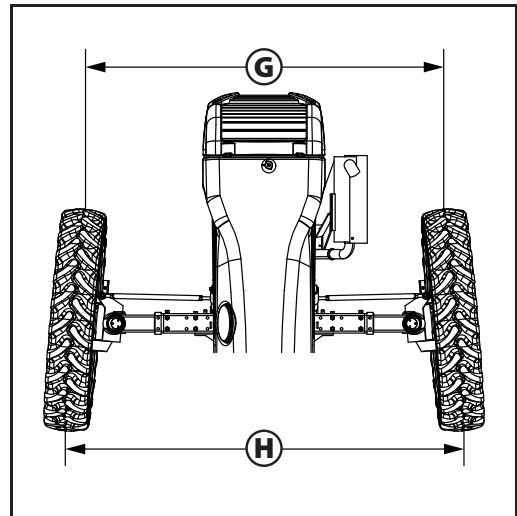
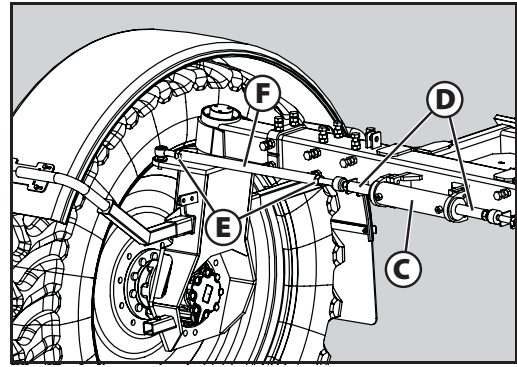

### **Boom**

---

#### **Check boom operator's manual**

Before operating your sprayer, check the boom operator's manual for any setup or maintenance required. Failure to do so could result in damage to the boom.

## 4 - Sprayer setup

---



### Starting the PRESIDIO

#### General information



WARNING! Before starting the engine, check all of the fluid levels; engine oil, hydraulic oil, coolant and fuel. Please read this manual completely to find the correct method of checking and filling fluid levels.

#### Preliminary operations

1. Verify the tightness of all nuts and bolts (For wheel nuts, see "Occasional maintenance" on page 87). Tightening of fasteners must always be the responsibility of the machine operator.
2. Set the battery isolation switch to ON (switch will light up).



3. Make sure the travel lever is in neutral position (N).



4. Make sure Parking brake is activated (Switch in 'down' position with indicator light on).



ATTENTION! Before starting, make sure that there is no one in the working area of the PRESIDIO.



WARNING! Never leave a battery charger connected to the PRESIDIO at high amp (boost) setting. Damage to the electronics may occur. To jump start the PRESIDIO, only use a charger for as long as necessary to start the engine.



WARNING! Either remove the battery or turn the battery isolation switch to OFF before charging the battery to avoid damaging the PRESIDIO electronics. See "Check the electrolyte level of the battery" on page 6.88.

# 5 - Sprayer setup

## Starting the engine

	0	 No circuit voltage	
	1	 Service voltage	
	2	Starting	

- Put the key into the ignition switch.
- Turn the key clockwise to position (1). The battery indicator light (9) turns on in the dashboard display. This position automatically starts the preheating of the engine when the outside temperature is low. The preheat indicator light (8) turns on (if necessary). Wait for the preheat indicator light to turn off before proceeding.
- Turn the key clockwise to position (2) to start the engine. Release the key as soon as the engine starts.

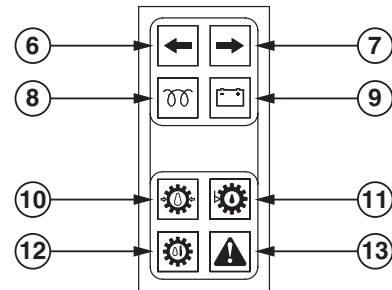

**WARNING!** If any of the bottom four warning lights are active (oil filter clogged, oil level low, high temperature, engine fault), immediately shut off engine and correct problem!

## Engine panel

On power-up, the Deutz Display performs a series of self-test routines. The progress of these is shown in the lower right-hand corner of the display. In the unlikely event of a fault occurring, the unit will emit a low-toned beep. The user can attempt to rectify the fault by reverting to the factory defaults.

Following a successful self-test, the Deutz Display will show engine data using the latest configuration settings held in it's non-volatile memory.



## Navigation keys

Press any of the middle keys (#2 - #4) to make the menu bar visible on the Deutz Display LCD. Press any key below the relevant icon to select a display mode.

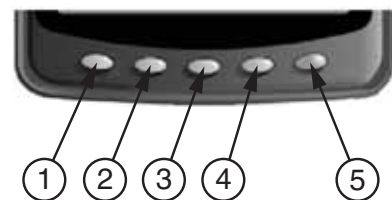

A folded page icon with an arrow on the page indicates that pressing the associated key will step through the various screens associated with a particular display format.



The menu bar will disappear after approximately five seconds of key inactivity.



**ATTENTION!** It is not recommended to press these keys while driving the machine.

## 5 - Sprayer setup

### Using the soft keys

The use of 'soft' keys vastly simplifies the Deutz Display operator interface by ensuring the user is only presented with active keys that are appropriate to the current function. This is achieved by displaying icons in the menu bar that represent the current function of each key.

Positioning the icons above the appropriate key allows each key's function to change while ensuring that the operator is always presented with a clear and unambiguous understanding of what each key press will do.

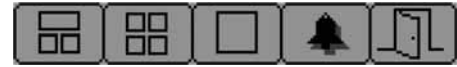

### Setting Display Contrast and Lighting

Pressing the right-most key (#5) when the menu bar is not displayed will bring up the lighting and contrast menu.

The LCD has four back-light levels that allow the display to be read in the dark.

- The appropriate level is selected by pressing key #1 to decrease the illumination or key #2 to increase it.

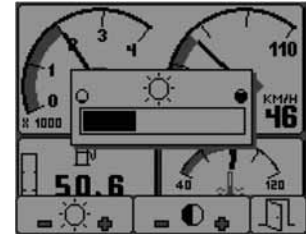

Adjusting the contrast of the LCD to an optimum level ensures that the display is clearly legible and that gray-scales are appropriately displayed.

- Contrast is reduced by pressing key #3 (which will tend to lighten the display) and increased by pressing key #4 (which will tend to darken the display).

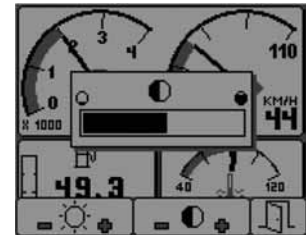

Press key #5 to exit the contrast and lighting menu.

The lighting and contrast settings are stored in non-volatile memory and will be used the next time the Deutz Display is powered up.



**ATTENTION!** If the display contrast is ever set so that the display is unreadable, making it difficult to adjust, press all four keys (#1 - #4) simultaneously. This will reset the contrast to a central value and will reset the lighting to full. No other settings are lost.

### The Main Engine Display

This display incorporates three independent windows and is intended to show the most important and frequently accessed engine data.

To select the main engine display, press any of the middle keys (#2 - #4) to show the top-level menu icons and then press key #1 (the left-hand key).

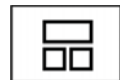

The main window (at the top of the display) shows two gauges; engine rpm on the left and speed on the right.









If speed data is not available, the right-hand gauge will display engine oil pressure instead. The window at the bottom-right of the display shows the coolant temperature. The window at the bottom-left of the display gives access to the fuel computer data and is similar to an automotive in-car fuel computer.



## 5 - Sprayer setup

Various parameters for the fuel computer can be displayed by repeated presses of key #1 (left-hand key) which scrolls through the following displays. Fuel parameters can only be shown if the required data is being received from the engine.

	<b>Instantaneous Fuel Rate</b> The instantaneous fuel rate received from the engine displayed as a volume per hour.
	<b>Average Fuel Rate per hour</b> If total fuel consumption and fuel rate are being received, then the average will be calculated since the last trip fuel and trip hours reset. This is displayed in units of volume per hour.
	<b>Average Fuel Consumption per distance</b> If vehicle speed is being received, then the average will be calculated since last trip fuel reset. This is displayed in units of volume per distance.
	<b>Trip Fuel</b> If total fuel used is received from the engine, then this will be calculated since the last reset.
	<b>Engine Hours</b> Total engine hours received from engine.
	<b>Trip Engine Hours</b> Engine hours since last reset. Calculated from Total Engine hours.

To reset one of the fuel computer parameters (that allows a reset), wait for the menu bar to disappear, then press and hold key #1 for at least 3 seconds.



Note: If key #1 is pressed and held before the menu bar disappears, then the display will move to the next parameter before resetting.



Note: Key #1 always scrolls to the next fuel computer parameter while in Main Engine Display mode (regardless of whether the menu bar is visible or not).

## 5 - Sprayer setup

### The Quad Display

The Quad Display shows four engine parameters simultaneously. There are four sets of Quad Display screens that the user can scroll through, giving quick access to a large amount of engine data. The bottom-left parameter is represented as a digital value, while the remaining 3 parameters are displayed as analog gauges.



To select the quad display, press any of the middle keys (#2 - #4) to show the top-level menu icons and then press key #2. Repeatedly pressing key #2 cycles through the four available screens.

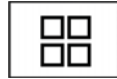

Using the adjust mode, each individual gauge displayed on any of the four screens can be configured by the user to show a different engine parameter selected from an extensive list (See "The Quad and Graph Parameters" on page 44).

The adjust mode is entered by pressing key #5 when the Deutz Display is running in quad display mode and the menu is visible (if the menu isn't visible, simply press any of the middle keys to make it re-appear).

From the adjust mode, the menu icons change to allow key presses to scroll through possible engine parameters for individual gauges. Pressing key #1 will cycle the top-left display, key #2 will cycle the top-right display, etc. To exit the adjust mode, press key #5.

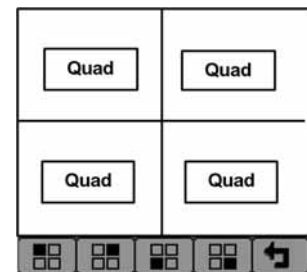

Note: The bottom-left parameter will always be represented as a digital value.

### The Graph Display

The graph display shows data trends in one large window and is analogous to a traditional data plotter. To select the graph display, press any of the middle keys (#2 - #4) to show the top-level menu icons, then press key #3.

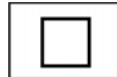

Data is shown in graph form, with the most recent data scrolling from the right of the display towards the left. The viewed time range can be adjusted in the configuration menu from 2, 10 or 30 minutes up to 1, 2, 4 or 8 hours (See "Configuration Menu" on page 47).

The maximum and minimum values of the Y axis (defining the span of readings displayed) are adjusted automatically to give the optimum view of visible data.



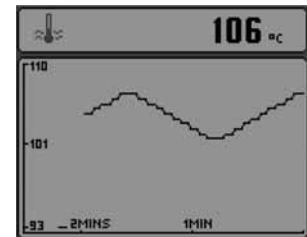











The data to be displayed can be selected by repeatedly pressing key #3 while in the graph display mode. The display cycles through all possible parameters, (See "The Quad and Graph Parameters" on page 44).



## 5 - Sprayer setup

### The Quad and Graph Parameters

The following list shows all of the engine parameters that can be displayed in the Quad and Graph screens:

	Parameters	Quad	Graph	Icon
a)	Engine Speed (rpm)	X	X	
b)	Coolant Temperature	X	X	
c)	Battery Voltage	X	X	
d)	Turbo Pressure	X	X	
e)	Coolant Pressure	X	X	
f)	Fuel Pressure	X	X	
g)	Engine Oil Pressure	X	X	
h)	Transmission Oil Pressure	X	X	
i)	Transmission Oil Temperature	X	X	
j)	Exhaust Temperature	X	X	
k)	Engine Oil Temperature	X	X	
l)	Inlet Manifold Temperature	X	X	
m)	Engine Torque (actual)	X	-	
n)	Accelerator Position	X	-	
o)	Fuel Rate	-	X	

### The Alarm Display Screen

The Deutz Display recognizes alarm messages from the engine via the data link. When a new alarm is received, the Deutz Display will start to beep. A flashing pop-up window will appear with the latest alarm details.

Pressing any key will display the alarm list screen which contains details of all previous alarms. Those that have already been acknowledged are shown as black text on a gray background.

New alarms that have not yet been acknowledged are shown as highlighted gray text on a black background. If engine hours data is available, the list will also indicate the engine hours when the alarm message was first received.



When first entering the alarm page, the list will automatically go to the most recent alarm received. If the list is longer than the screen size, the alarm list can be scrolled up and down using keys #1 & #2.

The screen cannot be exited until all alarms have been acknowledged by pressing key #3. Once all the alarms have been acknowledged (gray screen with black text), the exit icon above key #5 will be activated. Press key #5 to exit.

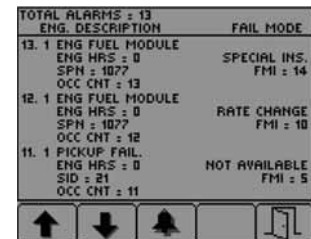

**i** Note: Alarm messages will be automatically cleared from the list if no longer received.

**i** Note: The alarm list screen can be viewed at any time by pressing key #4 from the main menu.

### Pop-up Messages and Warnings

In the configuration menu, the user can set the engine service interval in hours. When the Deutz Display determines that an engine service is due, it will display a "SERVICE REQUIRED" message overlaying the start-up screen which appears for seven seconds following power-up.

If the Deutz Display does not detect valid engine data, a flashing pop-up window will appear displaying a "Communications Failure" icon denoting this fault condition. Once engine data transmissions have been detected, the pop-up window will disappear and normal data display will continue.

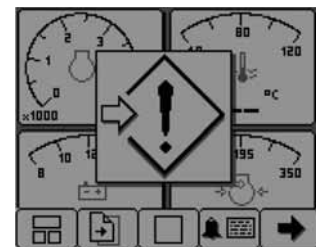

### Secure Settings - PIN

The Configuration menu is protected by a 4 digit security code. When attempting to open the configuration menu (by pressing and holding key #5), a pop up screen will appear to enter the PIN. To enter each digit, the corresponding key (1 - 4) must be pressed the number of times needed to display the desired number (one time for 1, five times for 5, etc.). Once all four digits have been entered, the fifth key is pressed to enter the PIN. After the correct PIN is entered, the configuration menu opens (See "Configuration Menu" on page 47).

**i** Note: The default PIN is set to "1111".

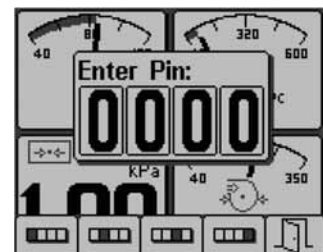



## 5 - Sprayer setup

### Incorrect PIN entry

If the PIN is entered incorrectly, the "Pin Incorrect" screen displays for 3 seconds. Then the display returns to the previous screen (before the "Enter Pin:" pop up screen).

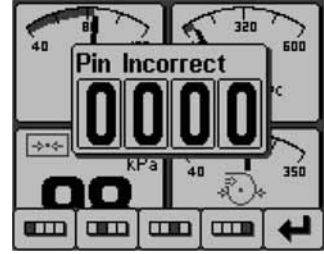

### Entering the Screen by accident

If the PIN entry screen is entered by accident (holding down on key #5), the user can exit out of the screen by pressing the 5th key. The "Pin Incorrect" screen will display for 3 seconds, then return to the previous screen.

### PIN Entry ON/OFF

From the configuration menu (after correct PIN entry), the "PIN Entry" function may be turned ON or OFF by selecting "SYSTEM" > "PIN SETTINGS". Make sure "PIN ENTRY" is highlighted (use up/down keys #1 or #2 if necessary) and press key #4 to turn the function ON or OFF:

- If the "PIN Entry" is "ON", pressing key #4 will turn it "OFF".
- If the "PIN Entry" is "OFF", pressing key #4 will cause the "Enter Pin:" screen to pop up. After entering the correct PIN, the "PIN Entry" function will be set to "ON".

**i** Note: The current "PIN Entry" setting will be active after leaving the configuration menu. If set to "ON", the correct 4 digit security PIN will be required to enter the configuration menu. If set to "OFF", no security PIN will be needed to enter the configuration menu.

### Changing the PIN

From the configuration menu (after correct PIN entry), the PIN can be changed by selecting "SYSTEM" > "PIN SETTINGS" > "PIN CHANGE". The "PIN CHANGE" menu will prompt the user to enter the current PIN. If the wrong PIN is entered, the "Pin Incorrect" screen will display for 3 seconds and the display will return to the top level configuration menu.

Once the PIN is entered correctly, the "Enter New Pin" screen will display. This prompts the user to enter the new PIN.

After the new PIN is accepted (by pressing the 5th key), the "Confirm" screen will prompt the user to re-enter the new PIN to confirm. Pressing the 5th key will display the "Pin Correct" (or "Pin Incorrect") screen for 3 seconds before returning to the configuration menu.





## Configuration Menu

The configuration menu allows the user to set various operating parameters and modes of the Deutz Display. These include such choices as imperial or metric units, scale limits for the speedometer gauges, engine service interval, etc.

The configuration menu is entered by pressing and holding key #5 for at least 3 seconds when the Deutz Display is in its normal operating mode. After entering the 4 digit PIN, the top-level configuration menu will be displayed on the LCD as shown here.

Keys #1 and #2 allow the operator to move up and down the menu, while key #4 enters the highlighted menu item. Key #5 exits the configuration menu and saves all configuration data into non-volatile memory.

The SETTINGS sub-menu allows the Deutz Display to be configured according to the user's preferences, while the SYSTEM accesses maintenance and low-level system configuration settings.

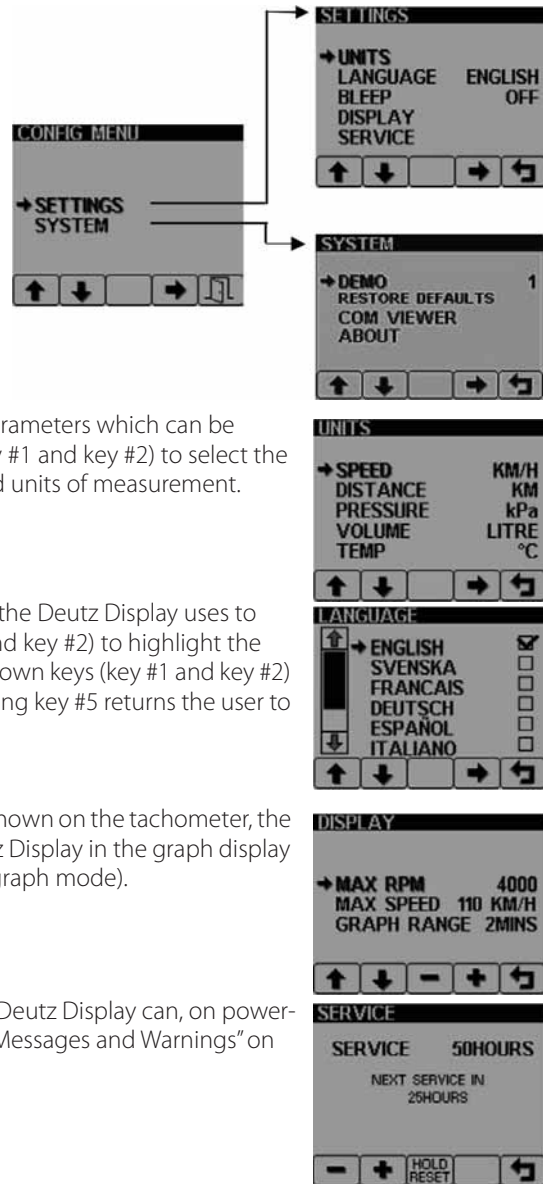

Selecting UNITS from the SETTINGS sub-menu gives access to five parameters which can be displayed in units selected from a list. Use the up and down keys (key #1 and key #2) to select the required parameter, then press key #4 to cycle through the permitted units of measurement. Pressing key #5 returns the user to the main SETTINGS menu.

The LANGUAGE sub-menu allows the user to select which language the Deutz Display uses to display messages and prompts. Use the up and down keys (key #1 and key #2) to highlight the required language and then press key #4 to select it. Use the up and down keys (key #1 and key #2) to select the desired language and then press key #4 to enter it. Pressing key #5 returns the user to the main SETTINGS menu.

The DISPLAY sub-menu allows the user to define the maximum rpm shown on the tachometer, the maximum speed with which the display scrolls when using the Deutz Display in the graph display mode (See "The Graph Display" on page 43 for further details of the graph mode).

SERVICE allows the user to set the engine service interval so that the Deutz Display can, on power-up, remind the operator when a service becomes due (See "Pop-up Messages and Warnings" on page 45 for details of the pop-up message that signals this event).

DEMO, the first item on the SYSTEM menu, allows the Deutz Display to run in a demonstration mode, showing its capabilities even if not connected to a valid engine data stream. There are three different demo modes. DEMO 1 has speed data simulated by the Deutz Display. DEMO 2 does not generate simulated speed data. DEMO 3 simulates various alarm conditions. For normal use, the demo mode must be switched OFF.

RESTORE DEFAULTS allows the user to reset all configuration data to the factory defaults. The user may select either metric or imperial units. The default values for each is shown to the right.

Setting	Metric	Imperial
Language	German	
Max RPM	3000	
Max Speed	110 KmH	70 MPH
Graph range	2 mins	
Speed	KmH	MPH
Distance	Km	Miles
Pressure	bar	PSI
Volume	L	Gal
Temperature	°C	°F

## 5 - Sprayer setup

### Driving

#### Driving in automotive mode (road)

1. With engine idling, set the speed range switch to ROAD mode.

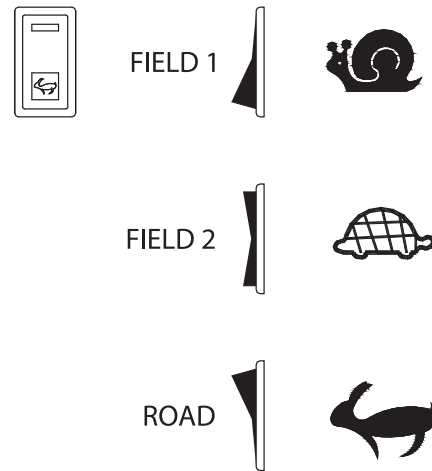

2. Disengage the parking brake (up position, indicator light off). The front ladder will raise into driving position.



3. Move the travel lever forward to advance, or backward to reverse to the approximate position indicated below for the desired speed.

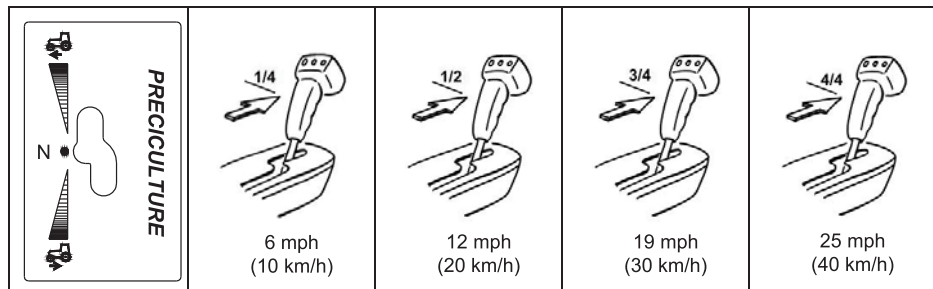

4. Press accelerator foot pedal (A) to increase engine rpm and begin moving.
5. Speed of travel will depend on how far the foot pedal is depressed and the position of the travel lever.



## 5 - Sprayer setup

### Stopping the vehicle in road mode

1. Release the accelerator pedal (A).
2. In the event of an emergency, apply brake using brake pedal (B).



3. In normal driving, return the travel lever slowly to neutral (N) position after releasing accelerator pedal.



4. Engage the parking brake (down position, indicator light on). The front ladder will lower into parked position.



## 5 - Sprayer setup

### Driving in normal mode (field)

1. Set the speed range switch to FIELD 1 or FIELD 2 mode.

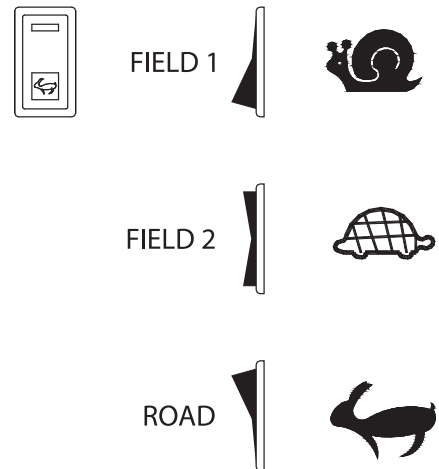

2. Disengage the parking brake (up position, indicator light off). The front ladder will raise into driving position.



3. Increase the engine rpm by rotating dial (E) located on the PRESIDIO instrument panel. Adjust from 1200 to 2100 rpm depending on the work to be carried out.

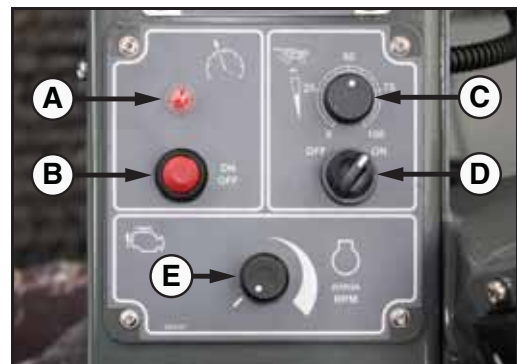

4. Move the travel lever forward to advance or backward to reverse.
5. The travel speed will depend on the position of the travel lever and throttle setting (rpm).



## 5 - Sprayer setup

### Limiting the speed (field mode only)

When the speed range switch is set to FIELD 1 or FIELD 2, the level of speed related to the position of the travel lever may be limited.

1. Turn dial (C) to desired percentage of speed range.
2. Turn switch (D) to ON position.

For example, if dial (C) is set to 50% with switch (D) "ON", then the total stroke of the travel lever covers half of the speed range selected.

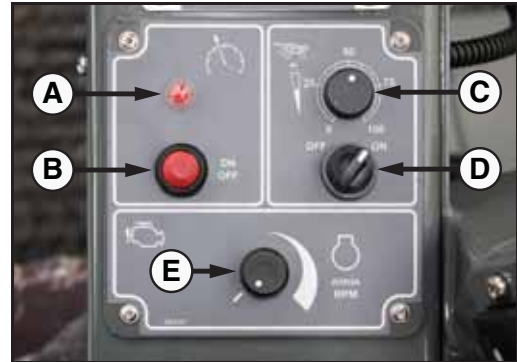

### Constant speed (field mode only)

When the speed range switch is set to FIELD 1 or FIELD 2, the constant speed function may be activated.

1. Press ON/OFF switch (B).

When activated, the indicator light (A) flashes. After 3 seconds without variation, the current speed is saved and the indicator light stays on continuously.

2. Press ON/OFF switch (B) again to deactivate constant speed.

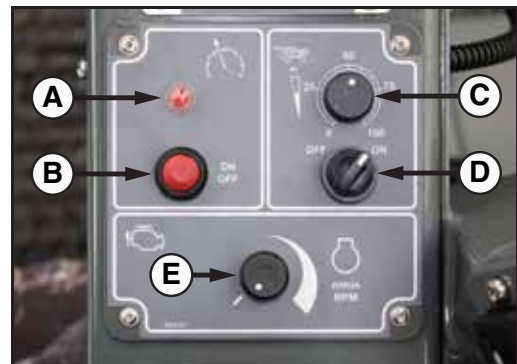

Note: Changing the speed or the speed limit dial (C) will lead to the storage of a new constant speed.

### Hydraulic all wheel lock

When the speed range switch is set to FIELD 1 or FIELD 2, it is possible to hydraulically lock all wheels to spin at the same speed.

1. Depress foot switch (1) to turn on "all wheel lock" mode.
2. Indicator lamp (2) on left instrument panel will light up.
3. Depress foot switch (1) again to turn off "all wheel lock" mode.
4. Indicator lamp (2) will turn off.



ATTENTION! All wheel lock does not work when the speed range switch is set to ROAD.



## 5 - Sprayer setup

### Stopping the vehicle in field mode

1. Return the travel lever slowly to neutral (N) position.



2. In the event of an emergency, apply brake using brake pedal (B).



3. Engage the parking brake (down position, indicator light on). The front ladder will lower into parked position.



### Shutting off the engine

1. Confirm that parking brake is engaged (down position, indicator light on), and that the front ladder is in the parked position (lowered).
2. Return the key to position (0).

	0	 No circuit voltage	
	1	 Service voltage	
	2	Starting	

3. Remove the key.
4. Set the battery isolation switch to OFF.



Note: System remains active for 30 seconds after isolation switch is turned off.

### Static braking

The PRESIDIO transmission has the capacity to brake the forward speed of the machine if the operator returns the travel lever toward the central neutral position.



**WARNING!** It is not recommended to make sudden movements of this lever at any time.

## 5 - Sprayer setup

### Operating the cab controls

#### Steering column adjustment

1. Loosen nut.
2. Adjust height.
3. Tighten nut.

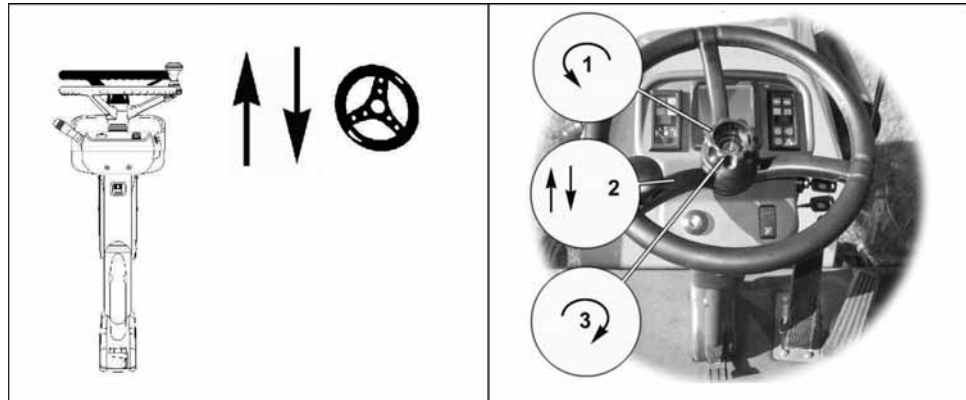

1. Hold down lever.
2. Adjust top of column.
3. Release lever.

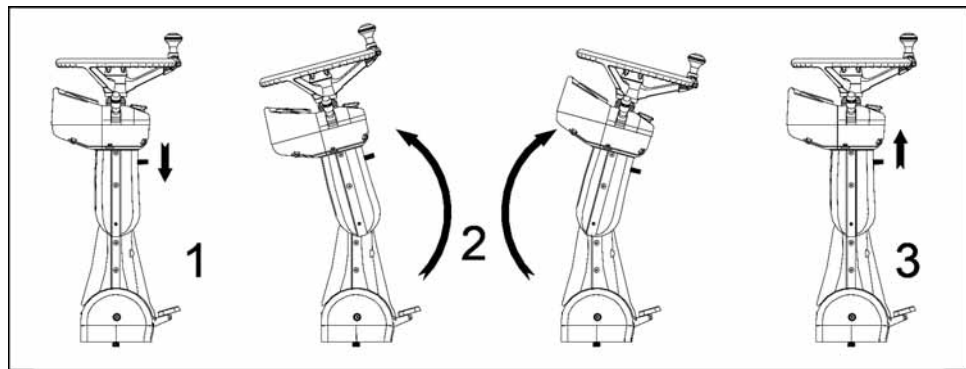

1. Push down lever.
2. Adjust column.
3. Release lever.

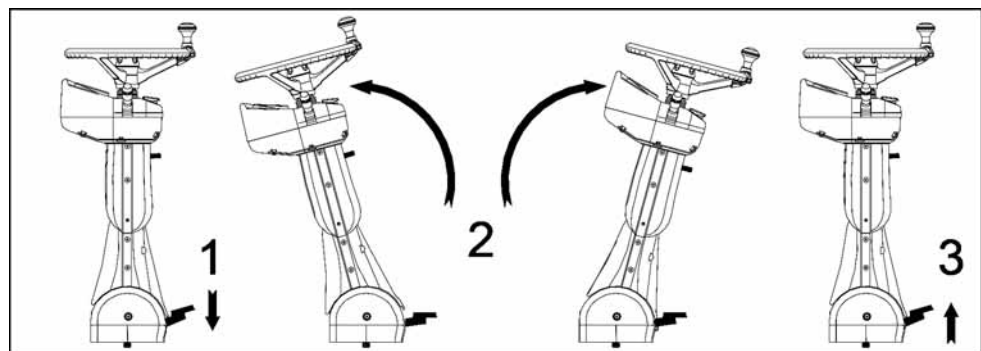

#### Operator seat adjustment

- Flip handle (1) forward to allow the fore/aft cushioning of the seat. Flip handle (1) rearward to lock the fore/aft cushioning effect.
- Lift lever (2) to move the seat forwards or rearwards.
- Lift lever (3) to raise seat. Push lever (3) down to lower seat.
- Lift handle (4) to swivel seat left/right. Release to lock.
- Lift lever (5) to adjust angle of seat back.
- Storage compartment (6) is located under seat. To open, press down on black latch and slide out.



Note: Seat height adjustment (3) only works when running.



### Turn signal/light switch

Left/right turn signal.

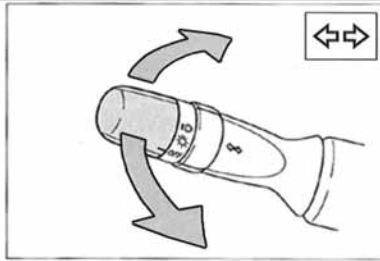

Parking lights on.

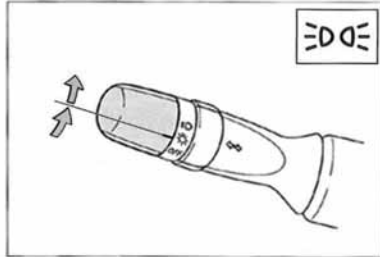

Headlights on.  
(Up - low beam)

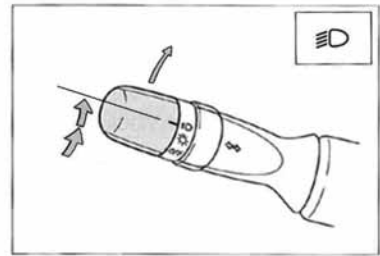

Headlights on.  
(Down - high beam)

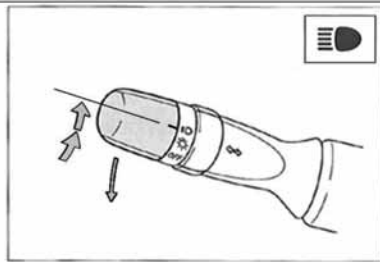

Note: Push on end of handle for horn.

### Overhead cab light

The overhead cab light is operated by pressing on either side of the light panel. To turn the light on, return the panel to the middle position. To turn the light off, tilt the panel to one side.



## 5 - Sprayer setup

### Side mirror controls

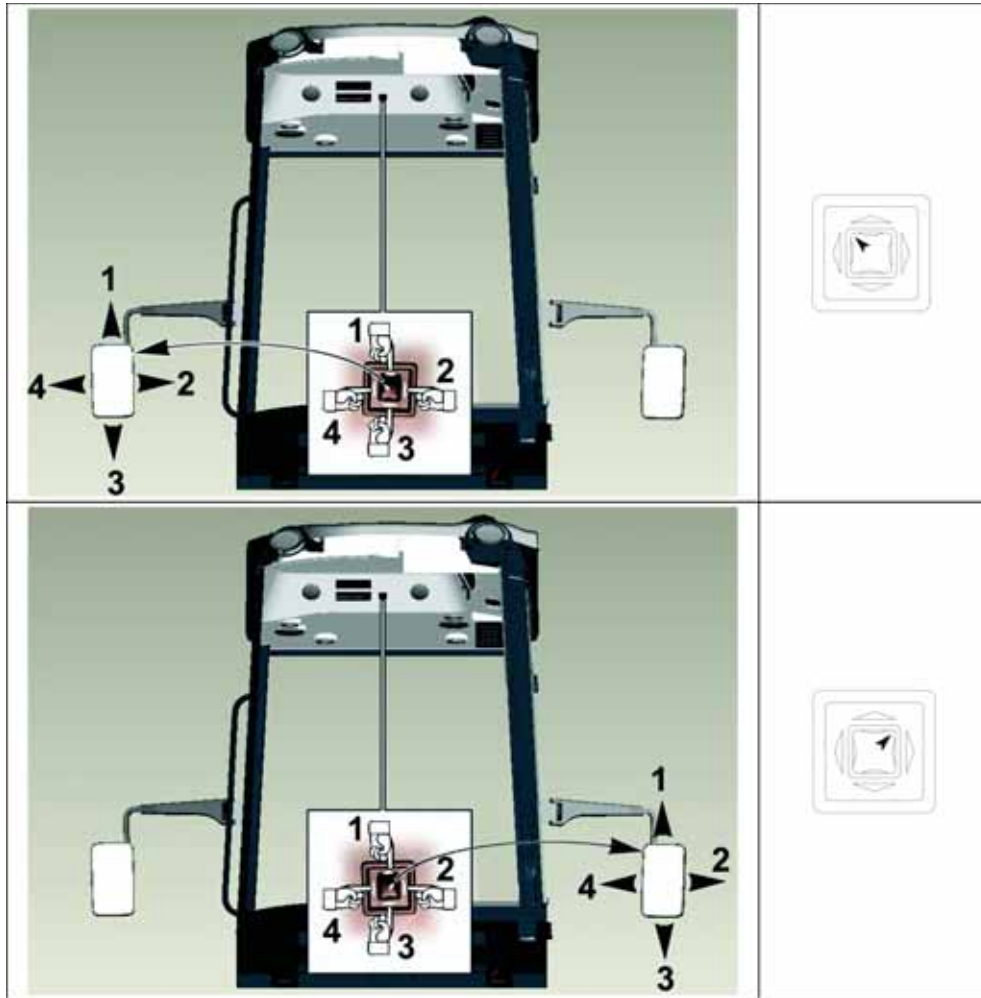

Select which mirror to adjust by turning the side mirror control dial to the left or right side.

1. Press to adjust selected mirror up
2. Press to adjust selected mirror right
3. Press to adjust selected mirror down
4. Press to adjust selected mirror left

### Air conditioning and heating control panel

- A. Power button
- B. Adjust down button
- C. Adjust up button
- D. Standby/External Temperature indicator
- E. Fan speed button
- F. Defrost indicator light
- G. Defrost button
- H. Display



When the panel is powered (ignition switch "ON"), it will briefly show the panel software version. Then the display's standby indicator (D) will start to blink, indicating that the panel is operating in standby mode.

To turn the panel on, press power button (A). The display will show the setpoint (desired) temperature.

To display external temperature, press and hold power button (A) for 2 seconds (while panel is on). The external temperature indicator (D) will light up and the external temperature will scroll once through the display. Indicator light (D) will turn off and display will return to setpoint temperature after displaying external temperature.

To turn the panel off, press power button (A) while panel is on. The panel will save current settings.

The display normally shows the setpoint temperature. It can also briefly display manual fan speed settings, external temperature or warn the operator when the system presents any failure.

#### Setting the desired temperature

To change the setpoint (desired temperature), press (B) or (C) to enter adjust mode. The setpoint temperature will flash in the display. Press (B) or (C) until the desired setpoint temperature is displayed. When the display stops flashing, the new setpoint is active.

#### Cooling

When the external temperature is below 41° F (5° C), the air conditioner will not be active.

When the external temperature is 41° F (5° C) or higher, the air conditioner will automatically turn on whenever the internal temperature is higher than the setpoint. The air conditioner will automatically turn off whenever the temperature is lower than the setpoint.

#### Heating

The heater will turn on whenever the internal temperature is lower than the setpoint.  
The heater will turn off whenever the internal temperature is higher than the setpoint.

#### Ventilation

The ventilation will work even if the air conditioner function is not activated. The panel has three different manual fan speeds; **u1** (low), **u2** (medium) & **u3** (high). Initially, the system will start in **Au** mode (automatic ventilation control), which will be controlled by the temperature setpoint.

To change the ventilation speed, press fan speed button (E) and then press the up button (C) or down button (B) to select the desired speed or automatic mode.

#### Defrost control

The defrost mode is manually activated by pressing the Defrost button (G). Air conditioning and Heating will turn on together with High fan speed. The Defrost indicator light (F) will stay on during the defrost cycle. Defrost mode automatically turns off after two minutes and returns to previous status. Defrost indicator light will flash twice at end of cycle.



Note: The air conditioner will not operate when the external air temperature is lower than 41° F (5° C).

## 5 - Sprayer setup

### Boom

#### Rear transport lock

The rear transport lock is manually operated to lock/unlock the rear hydraulic lift frame.

1. The rear transport lock is disengaged when both left and right lock arms are in storage position (A).
2. The rear transport lock is engaged when both left and right lock arms are in locked position (B).

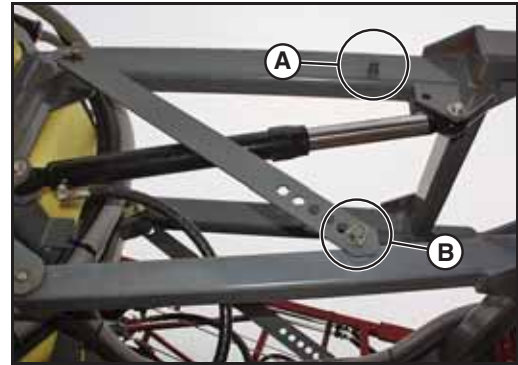

**WARNING!** The rear transport lock must be in storage position before folding/unfolding the boom. Failure to do so will cause damage to the boom.



**WARNING!** The boom must not be folded/unfolded while driving! Never use the folding/unfolding functions before sprayer has been stopped! Failure to do so will cause damage to the boom.

#### Safety info



**DANGER!** The rear transport lock must be engaged for road transport or for working under the machine.



**DANGER!** When folding or unfolding the boom, make sure that no persons or objects are in the operating area of the boom.



**DANGER!** Always follow the guidelines listed below when driving in areas with overhead power lines:

- Never use the folding/unfolding functions in areas with overhead power lines.
- Unintended boom movements can cause contact with overhead power lines.

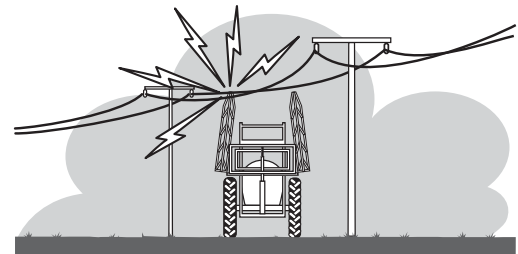

**ATTENTION!** Decal #10533003 is located inside the cabin. This label must be visible from the operator's seat.



**ATTENTION!** Only fold and unfold the boom on level ground.

#### Operating the boom

A separate "Boom Operator's Manual" is supplied with your sprayer and contains detailed information on boom safety, set-up, operation and maintenance.



**DANGER!** Important information on Safety, Operation and Maintenance specific to your boom configuration is detailed in the "Boom Operator's Manual" supplied with your sprayer. It must be read and fully understood by anyone intending to operate this equipment. Failure to do so could result in serious personal injury or death.

### Liquid system

#### Filling/washing location requirements

When filling the sprayer with chemicals and water, it is important to avoid spot contamination by spray chemicals in order to protect the subsoil water resources.

- A. If the sprayer is always filled at the same place, a special filling/washing location should be established. This should have a hard, liquid-impenetrable surface (e.g. concrete) and edges securing against run-off to the surrounding areas. The place should be drained to an adequate receptacle (e.g. slurry tank or similar).

Any spillage or washings should be retained and diluted in order to be distributed on a larger area to ensure minimal environmental impact and avoid build-up of larger chemical concentrations at one spot.

- B. Alternatively the sprayer can be filled in the field where the spraying is to take place. If so, choose a different location for each refilling.

If no other requirements of distances exist, the filling should not take place closer than:

- 1) 300 yards (meters) from any water supplies for drinking purposes,
- 2) 25 yards (meters) from treatment sumps and sewer drainage systems, and
- 3) 50 yards (meters) from surface water (watercourses, lakes and coastal waters) and from nature reserves.



ATTENTION! Legislation and requirements vary. Always follow local legislation in force at any time.



Note: It is the responsibility of the sprayer owner/operator to comply with all relevant legislation. HARDI® cannot undertake any responsibilities for incorrect operation and use.

#### Filling of water

Tank should normally be filled 1/3 with water before adding chemicals. Always follow instructions given on the chemical container!



WARNING! If the sprayer is put aside with liquid in the main tank, all MANIFOLD valves must be closed.

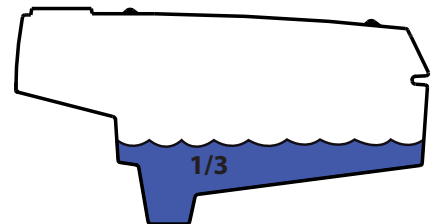

#### Filling of main tank

The main tank is filled via the 2 inch "Main" quick fill coupler located below the platform in the fluid working zone on the sprayer's left side. The fluid is filtered through a filling filter.

To fill the Main tank:

1. Remove the cap from the "MAIN" quick fill coupler and attach the external supply hose.
2. Start the water supply or remote fill pump that is connected to a clean water supply.
3. Open the "MAIN" tank filling valve.
4. Fill main tank to required volume.
5. Close the "MAIN" tank filling valve.
6. Turn off water supply or remote fill pump.
7. Remove external supply hose and secure the cap to the quick fill coupler.



## 5 - Sprayer setup

### Filling of rinse tank

The rinse tank is filled via the 2 inch "Rinse" coupler located below the platform in the fluid working zone on the sprayer's left side.

To fill the rinse tank:

1. Remove the cap from the "RINSE" quick fill coupler and attach the external supply hose.
2. Start water supply or remote fill pump that is connected to a clean water supply.
3. Open the "RINSE" tank filling valve.
4. When rinse tank is full, turn off the "RINSE" tank filling valve.
5. Turn off water supply or remote fill pump.
6. Remove external supply hose and secure the cap to the quick fill coupler.



**ATTENTION!** Only fill the rinse tank with clean water. To avoid algae developing, always drain the rinse tank if the sprayer is not used for an extended period of time.

### Filling of clean water tank

A clean water tank is fitted below the platform in the clean zone on the sprayer's left side. The tank is easily removed for filling, or can be filled with a hose without removal.

To remove the clean water tank, grab the handle at the top of the tank and press up on the metal locking tab. Then tilt the tank forward and lift the tank clear of the bottom supports.

Remove the clean water tank lid (A) and fill with clean water only. Replace the tank by placing the bottom of the tank in the bottom supports, then push the top of the tank back until the metal lock tab closes around the tank handle. It may be necessary to pull the metal locking tab down or forward to secure the tank.

To release water from the clean water tank, use valve (B). The water from this tank is for hand washing, cleaning of clogged nozzles, etc. Only fill the clean water tank with clean water.

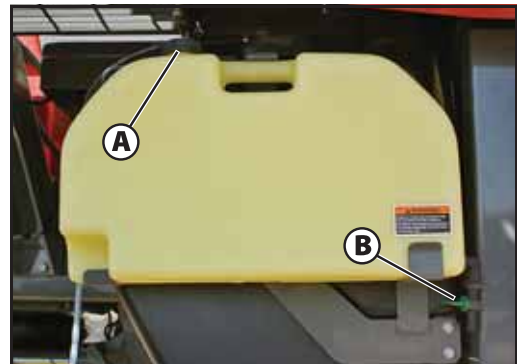

**WARNING!** Although the clean water tank is only filled with clean water, this water must never be used for drinking.

## 5 - Sprayer setup

### Agitation

The agitation in the Main Tank can be controlled from the work zone beside the Self propelled sprayer using the external electrical controls. It can also be controlled from the cabin.

For controlling the agitation (on/off) via the external electrical controls:

1. Flip toggle switch (5) up to set agitation to maximum.
2. Flip toggle switch (5) down to set agitation to minimum (off).



Note: The HARDI® spray center must be turned on inside the cab to operate external electrical controls (See "Spraying controls from the cab" on page 64).

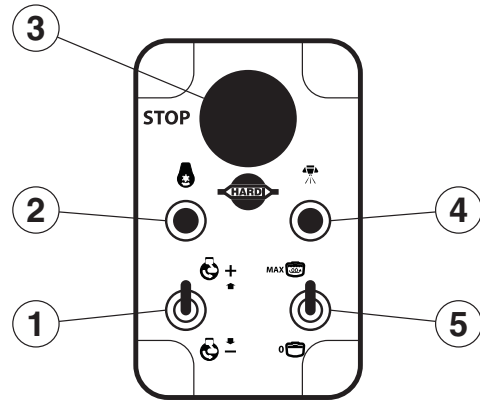

For controlling agitation from inside the cab:

1. Press top of switch (A) to increase the agitation of the liquid in the main tank.
2. Press bottom of switch (A) to decrease the agitation of the liquid in the main tank.



ATTENTION! Too much agitation may cause foam in the tank. The amount of foam depends on what types of chemicals are being used and how much water is in the tank. Agitation should be adjusted according to the volume of the liquid remaining in the main tank.

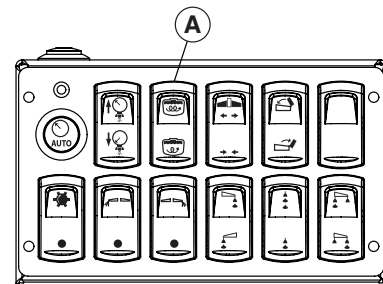

### Agitation before re-starting spraying

If a spraying job has been interrupted for awhile, severe sedimentation can occur depending on chemicals being used. When re-starting the spray job, it might be necessary to agitate the liquid.

1. Engage the spray pump.
2. Adjust the engine speed to at least 1800 rpm.
3. Adjust agitation to maximum.
4. Agitation should be continued for at least 10 minutes.
5. Adjust agitation back to normal level.

## 5 - Sprayer setup

---

### Parking the sprayer

To avoid spot contamination, the sprayer should always be parked at either the washing/filling location or under a roof to avoid rainfall washing chemical residues from the sprayer's surfaces.

- Parking at the washing/filling location will retain residues.
- Always park the machine out of reach of children, animals or unauthorized persons.

---

### Safety precautions - crop protection chemicals



WARNING! Always be careful when working with crop protection chemicals!



WARNING! Always wear correct protective clothing before handling chemicals!

### Personal protection

Depending on chemical type, protective gear/equipment should be worn to avoid contact with the chemicals, e.g.:

- Gloves
- Waterproof boots
- Headgear
- Respirator
- Safety goggles
- Chemical resistant overalls



WARNING! Protective clothing/equipment should be used when preparing the spray liquid, during the spray job and when cleaning the sprayer. Follow the chemical manufacturer's instructions given on the chemical label.



WARNING! It is always advisable to have clean water available, especially when filling the sprayer with chemicals.



WARNING! Always clean the sprayer carefully and immediately after use.



WARNING! Only mix chemicals in the tank according to directions given by the chemical manufacturer.



WARNING! Always clean the sprayer before changing to another chemical.

---

### Chemical Filling

Chemical filling can be done via the TurboFiller.



ATTENTION! The scale in the hopper is only to be used as a reference! It is recommended to use a measuring jug for best accuracy.



ATTENTION! The Chemical Container Cleaning device uses spray liquid to rinse concentrated chemicals from containers. Always rinse the chemical containers with clean water several times until they are clean before disposal.



ATTENTION! The hopper rinsing device uses spray liquid to rinse concentrated chemicals from the hopper! The FILLER must always be cleaned together with the rest of the sprayer when the spray job is done.



## 5 - Sprayer setup

### Filling chemicals via the TurboFiller

1. Fill the Main Tank at least 1/3 with water (unless something else is stated on the chemical container label).
2. Turn the Suction valve to "Suction from main tank".
3. Turn on the Pressure valve to "TurboFiller".
4. Turn on the Spray Pump via the external electrical control.
5. Increase the engine speed to 2000 rpm.
6. Open the TurboFiller lid. Open the TurboDeflector valve.
7. Measure the correct quantity of chemicals and slowly add it into the hopper only as fast as the transfer device can flush it down.
8. If the chemical container is empty, it can be rinsed using the Chemical Container Cleaning device. Place the container over the multi-hole nozzle and push the upper lever to the left of the TurboFiller.
9. Close the TurboFiller lid when finished.

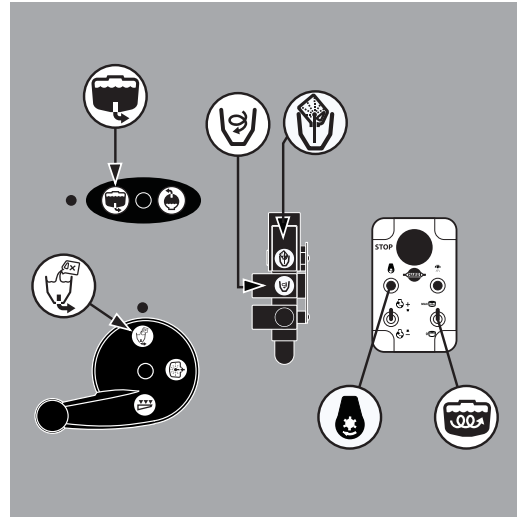

DANGER! Always wear face shield and other appropriate personal safety equipment when filling chemicals.



DANGER! Do not press the lever for the Chemical Container Cleaning device unless the multi-hole nozzle is covered by a container or the TurboFiller lid is closed to avoid spray liquid hitting the operator.



Note: The HARDI® spray center must be turned on inside the cab to operate external electrical controls.

### Rinsing TurboFiller

10. Turn the Suction valve to "Suction from rinse tank".
11. Check to make sure the TurboFiller lid is securely closed.
12. Rinse the hopper by using the Control valves on the TurboFiller, then turn them off.
13. Turn the Pressure valve to "Boom spraying".
14. Turn the Suction valve back to "Suction from main tank".
15. Continue filling the main tank.

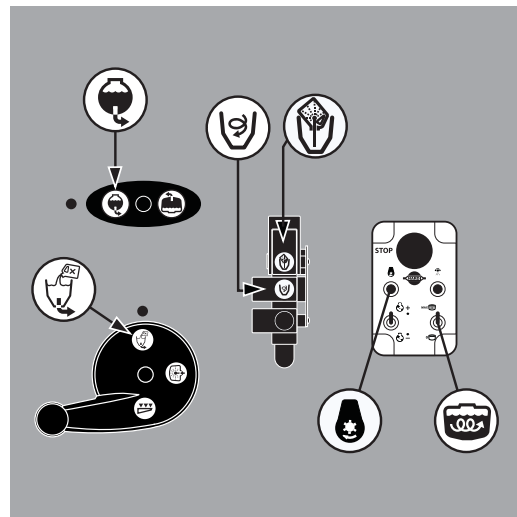

### Prepare sprayer for Spraying

Before entering the cabin, turn the Pressure valve to "Boom spraying" position and Suction valve back to "Suction from main tank". The rest of the functions for spraying can be controlled from the cabin.

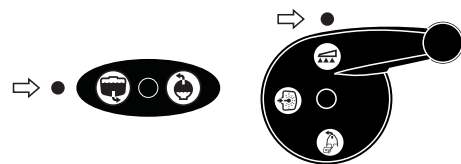

## 5 - Sprayer setup

### Spraying controls from the cab

Set the engine rpm from the PRESIDIO instrument panel.

1. Adjust the engine rpm by rotating dial (E) located on the PRESIDIO instrument panel.

The functions for spraying can be controlled from the HARDI® spray center located to the right of the armrest.

2. Press Main ON/OFF switch (2) to turn the HARDI® spray center on.
3. Status LED (1) will be lit.

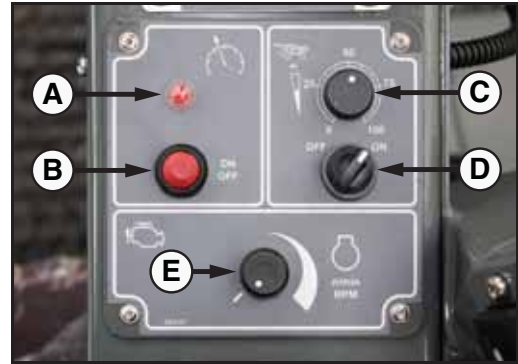

4. Press button (7) to engage automatic mode. Pump will start.
5. Press switch (3) to disengage the Automatic Variable Rate.
  - Press top of switch to increase spray pressure.
  - Press bottom of switch to decrease spray pressure.
6. Press switch (4) to manually select the level of the agitation.
  - Press top of switch to increase agitation.
  - Press bottom of switch to decrease agitation.

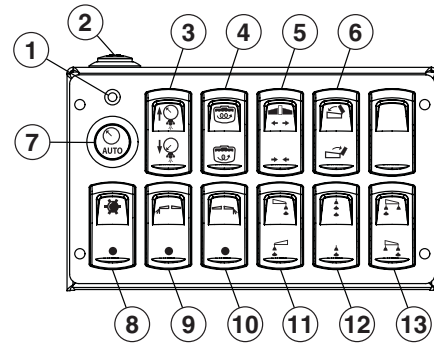

### Electrically controlled end nozzle (optional)

The boom can be fitted with end nozzles.

1. Press switch (9) to operate the end nozzle on the left side of the boom.
2. Press switch (10) to operate the end nozzle on the right side of the boom.

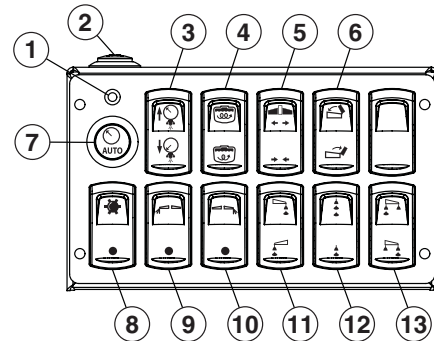

### Foam marker controls (optional)

If the boom is equipped with foam marker, the following switches are used.

1. Press switch (11) to choose left or right side foam dropper.
2. Press switch (12) to control the frequency of the foam drops.
3. Press switch (13) to switch between inner and outer foam droppers (Dual Fold Booms only).

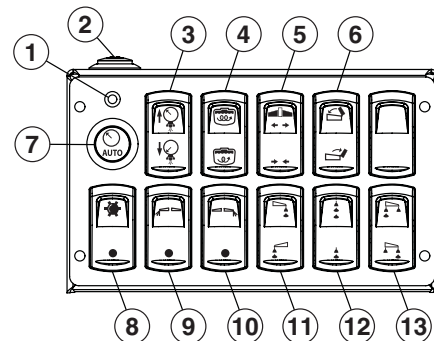

### Cleaning

---

#### General information

In order to derive full benefit from the sprayer for many years, the following service and maintenance program should be followed.



ATTENTION! Always read the individual paragraphs. Read instructions for service/maintenance jobs carefully before starting the job. If any portion remains unclear or requires facilities which are not available, then for safety reasons, please leave the job to your HARDI® dealer's workshop.



ATTENTION!

Clean sprayers are safe sprayers.

Clean sprayers are ready for action.

Clean sprayers cannot be damaged by pesticides and their solvents.

---

#### Guidelines

1. Read the whole chemical label. Take note of any particular instructions regarding recommended protective clothing, deactivating agents, etc. Read the detergent and deactivating agent labels. If cleaning procedures are given, follow them closely.
2. Be familiar with local legislation regarding disposal of pesticides washings, mandatory decontamination methods, etc. Contact the appropriate department, e.g. Dept. of Agriculture.
3. Pesticide washings can usually be sprayed out on a soakaway. This is an area of ground that is not used for cropping. You must avoid seepage or runoff of residue into streams, water courses, ditches, wells, springs, etc. The washings from the cleaning area must not enter sewers. Drainage must lead to an approved soakaway.
4. Cleaning starts with calibration, as a well calibrated sprayer will ensure the minimal amount of remaining spray liquid.
5. It is good practice to clean the sprayer immediately after use and thereby render the sprayer safe and ready for the next pesticide application. This also prolongs the life of the components.
6. It is sometimes necessary to leave spray liquid in the tank for short periods, e.g. overnight, or until the weather becomes suitable for spraying again. Unauthorized persons and animals must not have access to the sprayer under these circumstances.
7. If the product applied is corrosive, it is recommended to coat all metal parts of the sprayer before and after use with a suitable rust inhibitor.

---

#### Use of rinse tank and rinsing nozzles

The incorporated rinse tank has three different purposes:

- A. Full internal rinsing (in-field before cleaning or when using same chemicals again soon).
- B. Flushing spray circuit without diluting main tank contents (when spray job is interrupted).
- C. Full internal cleaning (before storage or when switching chemicals).



ATTENTION! The cleaning procedures require the TurboFiller to be cleaned out beforehand (directly after the last chemical filling). If the TurboFiller has not been cleaned, it must be cleaned before performing cleaning procedures A, B or C (See "Rinsing TurboFiller" on page 63).



ATTENTION! Do NOT add any cleaning detergents to the rinse tank. If cleaning agents are to be used, they should be added to the main tank.

## 5 - Sprayer setup

---

### A. Full internal rinsing

In-field diluting of remaining spray liquid residues in the spraying circuit for spraying the liquid in the field, before cleaning the sprayer.



Note: This rinsing is adequate/sufficient when the sprayer is going to be used again shortly (e.g. next day) in same or similar crops (no risk of cross contamination and subsequent crop damages).



WARNING! If the next crop to be sprayed is sensitive to the latest chemical used, then a full cleaning should be carried out. See "C: Full internal cleaning (Soak wash)" on page 68.



WARNING! Never clean the sprayer if there are risks of contamination of surface or underground water! Choose a different spot for cleaning every time to avoid spot contamination to build up.

This rinsing procedure will rinse the spraying circuit and main tank as follows:

1. Open the spray boom (if it isn't already opened) and lower the boom.
2. Empty the sprayer as much as possible. Turn the agitation valve off (no agitation). Allow the pump to run until all nozzles stop spraying to ensure that all relevant liquid has been expelled.
3. Turn the Suction valve to "Suction from rinse tank."
4. Turn on the Agitation valve.
5. Engage the pump.
6. Use 1/3 of the rinse tank contents at this valve setting.
7. Turn off the Agitation Valve.
8. Wait 10 seconds, then turn Pressure valve to "Rinse nozzles"
9. Rinse main tank with rinse nozzles for 20 seconds, then turn Pressure valve back to "Boom spraying".
10. Flush the CycloneFilter by holding the return valve in the flushing position (3 dots) for 10 seconds. This will flush out the sedimentations in the bottom of the filter. Leave CycloneFilter return valve in normal spraying position (2 dots).
11. Turn the Suction valve to "Suction from main tank".
12. Open the Boom Spray nozzles with the ON/OFF switch.
13. If powder has been used, turn on the agitation from the control panel. If the agitation is too strong, you can decrease it gradually from the cabin. Spray out the contents fully. If spraying in the field, choose a different location each time to distribute the spray liquid residues over larger areas. Continue until all fluid is expelled from the boom tubes and nozzles.
14. Turn the Suction valve to "Suction from rinse tank".
15. Turn the Pressure valve to "Rinse nozzles". Use approximately 1/6 of the rinse tank contents to rinse main tank.
16. Turn the Pressure valve back to "Boom spraying". Turn the Suction valve to "Suction from main tank". Turn on the Boom Spray nozzles and spray until the Main Tank is empty.
17. Repeat step 14-16 another 3 times using 1/6 off the rinse tank contents in each of the 3 sequences until the Rinse Tank is empty.
18. Shut off nozzles once the rinsing process is completed.

### B. Flushing spraying circuit without diluting main tank contents

This procedure is used to flush the pump, operating unit, spray lines, etc. in case of interruption in spraying before main tank is empty (e.g. beginning rain, etc.).

#### Flushing of the liquid system

1. Turn off the pump.
2. Leave the Pressure valve turned to "Boom spraying" position.
3. Turn the Suction valve to "Rinse tank" position.
4. Turn the CycloneFilter return valve to "no return flow" position (1 dot) to avoid dilution of main tank contents.
5. Turn off the agitation valve (no agitation).
6. Turn on the Boom nozzles.
7. Engage the pump and spray water from rinse tank in the field until all nozzle tubes/nozzles are flushed with clean water.
8. Disengage the pump.



WARNING! Don't turn Boom Spray nozzles off until the pump has fully stopped. Otherwise diluting of main tank contents will occur.



ATTENTION! It is advisable to increase the forward speed (double if possible) and reduce the pressure to 20 psi (1.5 bar) when spraying diluted remaining liquid in the field just sprayed.



ATTENTION! If a cleaning procedure is given on the chemical label, follow it closely.



ATTENTION! If the sprayer is cleaned with a high pressure cleaner, lubrication of the entire machine is recommended.

## 5 - Sprayer setup

---

### C: Full internal cleaning (Soak wash)



Note: This cleaning procedure is always used when:

- A. The next crop to be sprayed is at risk to be damaged by the chemical just used, or
- B. The sprayer is not going to be used again for same chemical or crop right away, or
- C. Before any repair or maintenance job is going to be carried out on the sprayer.



Note: Washing of the sprayer between jobs with incompatible chemicals must be done according to instructions from the chemical producer. Use e.g. AllClearExtra, as this is a commonly used cleaning agent. If your chemical manufacturer suggests another cleaning agent and/or another cleaning procedure, you must follow that.

Procedure for wash with a cleaning agent, e.g. AllClearExtra:

1. Rinse the sprayer in the field (See "A. Full internal rinsing" on page 66).
2. Drive to farm fill station.
3. Prepare sprayer for cleaning with cleaning agent, e.g. AllClearExtra. Fill water in the main tank to 10% of capacity (Fill the rinse tank completely. This water is used later for rinsing).
4. Turn Suction valve to "Suction from main tank".
5. Turn Pressure valve to "Boom spraying". Verify that all Boom nozzles are shut off.
6. Turn on the Agitation Valve.
7. Engage the pump.
8. Allow the liquid to circulate for 3 minutes.
9. Turn the Pressure valve to "TurboFiller".
10. Open the TurboFiller deflector valve and allow liquid to circulate for 3 minutes.
11. Close the lid and activate the container rinsing valve to clean the inside of the hopper.
12. Shut off container rinsing valve and the deflector valve on the TurboFiller.
13. Turn Pressure valve to "Boom spraying". Verify that all Boom nozzles are shut off.
14. Allow the liquid in the main tank to circulate for a minimum of 3 minutes with the nozzles off to clean the return lines from the boom to the tank.
15. Spray out water with cleaning agent and chemical residue. Set the spray pressure at 45 - 70 psi (3-5 bar). Note that the washing water still contains active chemical and choose an appropriate area to spray it out. Alternately, the washing water can be dumped at the Filling/washing location and retained in an appropriate receptacle (E.g. slurry tank or similar). Spot contamination and accumulation must be avoided. Continue to spray until all liquid is expelled from the boom tubes and nozzles.
16. Shut off all nozzles with the main ON/OFF switch.
17. Rinse the sprayer again with clean water to rinse out all remains of the cleaning agent (See "A. Full internal rinsing" on page 66). Do this to remove the cleaning agent from the fluid system, which could damage the next spray chemical filled into the main tank.
18. Include rinsing of the TurboFiller. Operate all valves during this process.
19. Remove all filters (pressure, in-line and nozzle filters) and clean the filter screens using clean water and detergent.



ATTENTION! The rinsing nozzles cannot always guarantee a 100% cleaning of the tank. Always clean manually with a brush afterwards, especially if crops sensitive to the chemical just sprayed are going to be sprayed afterwards!



Note: It is the responsibility of the sprayer operator or owner that the sprayer is cleaned sufficiently to avoid contamination of the environment, crop damages and health & safety hazards to operator and the public. HARDI® cannot be held responsible for any damages or incidents related to insufficient cleaning.

### **Use of detergents**

It is recommended to use an appropriate cleaning detergent suitable for cleaning agricultural sprayers.

- The cleaning detergents which contain a suitable lube or conditioner is recommended.
- If for some reason this is not available and e.g. triple ammonia water is used, it is important to rinse the circuit immediately after and add some lubricant to the rinsing water to avoid e.g. ball valves seizing up.
- Use of automotive antifreeze/radiator coolant (ethylene glycol) will protect the valves, seals etc. from drying or seizing up.

---

### **Technical residue**

Inevitably a quantity of spray liquid will remain in the system. It cannot be sprayed properly on the crop, as the pump takes in air when the tank is about to be empty.

This Technical Residue is defined as the remaining liquid quantity in the system as the first clear pressure drop on the pressure gauge is read.

The dilutable residue must be diluted 10 times with clean water and sprayed to the crop just sprayed before cleaning the sprayer.

---

### **Cleaning and maintenance of filters**

Clean filters ensure:

- Sprayer components such as valves, pumps and operating unit are not hindered or damaged during operation.
- Nozzle blockages do not occur while spraying.

# 5 - Sprayer setup

---



### Lubrication

#### General information

Always store lubricants in a clean, dry and cool place - preferably at a constant temperature to avoid contamination from dirt and condensation. Keep oil filling jugs, hoppers and grease guns clean, and clean the lubricating points thoroughly before lubricating. Avoid prolonged skin contact with oil products. Always follow the recommendations concerning quantity. If no quantity is indicated, lubricate until new grease becomes visible.

#### Table of recommended lubricants

Components	Capacity	Capacity (with filter)	Recommended lubricants
Deutz TDC2012 Engine		28 quarts (26.5 liters)	Chevron Delo® 400 LE SAE 15W-40
Hydraulic Transmission and Hydraulic system	45 gallons (170 liters)		Chevron Rando® HDZ ISO 046
Wheel gear boxes	1.6 quarts (1.5 liters)		Mystik® JT-7® Multi-Purpose Gear Lubricant SAE 80W-90
Coolant	26.4 quarts (25 liters)		Chevron Supreme Antifreeze/Coolant concentrate (227800) (Diluted 50/50)
General lubrication	--		Universal Lithium grease, NLGI No. 2 SHELL RETINAX EP2, CASTROL LMX GREASE



Note: The values in the table above are general capacities. Always use the level indicated by the gauge when filling.

## 6 - Maintenance

### Service and Maintenance intervals

#### Boom and engine manuals

The boom and engine manuals supplied with the PRESIDIO self-propelled sprayer each contain necessary maintenance information in addition to the chart below. Please follow the recommended service and maintenance instructions in the separate HARDI® boom manual and Deutz engine manual.

#### Service and maintenance chart

Service/Maintenance tasks	Further information
<b>Daily/Every 10 hours</b>	
Fill the fuel tank	See "Filling the fuel tank" on page 33
Check engine oil level	See "Engine oil level" on page 82
Check hydraulic oil level	See "Hydraulic oil level" on page 75
Inspect hydraulic hoses	See "Hydraulic hoses" on page 76
Tighten wheel nuts	See "Tighten wheel nuts" on page 74
Inspect engine air filter (primary)	See "Engine air filter maintenance" on page 84
Clean the engine radiator	See "Cleaning the radiator" on page 77
Check coolant level	See "Coolant level" on page 83
Drain water from water separator (fuel system)	See "Water separator (fuel system)" on page 84
Bleed compressed air tank	See "Air reservoir" on page 76
Clean CycloneFilter	See "CycloneFilter maintenance" on page 74
Inspect suspension air bags	See "Pneumatic suspension" on page 76
<b>After first 80 hours</b>	
Change engine oil and filter	See "Engine oil level" on page 82
Change oil in reduction gears	See "Maintaining reduction gear of rear wheel motor" on page 80
Replace fuel filter	See "Replacing the fuel filters" on page 85
Empty dust discharge valve	See "Engine air filter maintenance" on page 84
Inspect engine air filters (primary and security)	See "Engine air filter maintenance" on page 84
Check fan belt tightness	See Deutz manual (TCD 2012 V2)
Replace hydraulic oil filter	See "Hydraulic oil filter replacement" on page 75
Check tire pressure	See "Tire pressures" on page 98
Bleed fuel tank	See "Bleed fuel tank" on page 86
Grease frame	See "Greasing the frame" on page 81
Inspect brake accumulator	See "Brake accumulator" on page 90
Check brakes efficiency	See "Checking the efficiency of the brakes" on page 78
Check parking brake efficiency	See "Checking the efficiency of the parking brake" on page 78
<b>Every 250 hours</b>	
Change engine oil and filter	See "Engine oil level" on page 82
Change oil in reduction gears	See "Maintaining reduction gear of rear wheel motor" on page 80
Replace fuel filter	See "Replacing the fuel filters" on page 85
Empty dust discharge valve	See "Engine air filter maintenance" on page 84
Inspect engine air filters (primary and security)	See "Engine air filter maintenance" on page 84
Check fan belt tightness	See Deutz manual (TCD 2012 V2)
Replace hydraulic oil filter	See "Hydraulic oil filter replacement" on page 75
Check tire pressure	See "Tire pressures" on page 98
Grease frame	See "Greasing the frame" on page 81
Inspect brake accumulator	See "Brake accumulator" on page 90
Check brakes efficiency	See "Checking the efficiency of the brakes" on page 78
Check parking brake efficiency	See "Checking the efficiency of the parking brake" on page 78
<b>After first 500 hours</b>	
Change hydraulic oil and filter	See "Draining the hydraulic reservoir" on page 76, "Filling the hydraulic oil reservoir" on page 75 and "Hydraulic oil filter replacement" on page 75

### Service and maintenance chart (continued)

Service/Maintenance tasks	Further information
<b>Every 1000 hours</b>	
Change hydraulic oil and filter	See "Draining the hydraulic reservoir" on page 76, "Filling the hydraulic oil reservoir" on page 75 and "Hydraulic oil filter replacement" on page 75
Replace engine air filters (primary and security)	See "Engine air filter maintenance" on page 84
Replace coolant	See "Coolant level" on page 83
Replace fuel pre-filter cartridge	See "Replacing the water separator element" on page 85
Bleed fuel tank	See "Bleed fuel tank" on page 86
<b>Every 6 months</b>	
Replace cabin air filters (charcoal and paper)	See "Activated carbon filters (cabin)" on page 78
<b>Every year</b>	
Check air conditioner charge	Contact your local HARDI® Dealer
<b>Every 3 years</b>	
Check hydraulic accumulator	See "Maintaining boom paralift" on page 80
Inspect compressed air tank	See "Air reservoir" on page 76
<b>Every 5 years</b>	
Replace brake accumulator	See "Brake accumulator" on page 90
<b>Every 10 years</b>	
Replace hydraulic accumulator	See "Maintaining boom paralift" on page 80
Replace compressed air tank	Contact your local HARDI® Dealer
<b>Occasional Maintenance</b>	
Various occasional maintenance tasks	See "Occasional maintenance" on page 87



Note: Repeated intervals are to be followed regardless of any "First time" maintenance between intervals (e.g. when at 250 hours, perform all recommended tasks even if they were performed at 80 hours).

## 6 - Maintenance

### Presidio maintenance

#### Tighten wheel nuts

Verify the tightness of all wheel nuts to 250 Ft/lb (340 Nm).

- Tightening sequence: See illustration and tighten in order of numbering.



#### CycloneFilter maintenance

To service the CycloneFilter:

1. Turn the Pressure valve to a function other than "Boom spraying".
2. Unscrew filter lid (A) (accessible from the platform).
3. Lift the lid and filter (B) from housing.
4. Turn the two locks (C) outwards to unlock the filter from the lid.
5. Separate filter from the integrated filter guide in the lid and clean the filter.

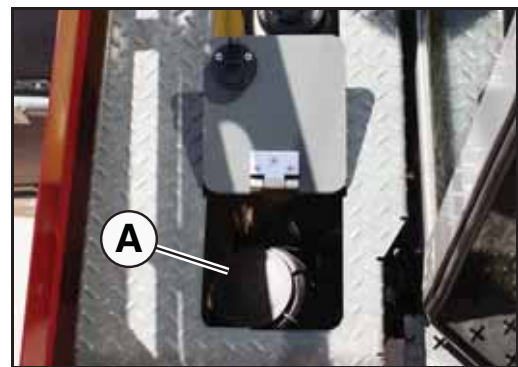

To reassemble:

1. Grease the two O-rings on the lid/filter guide. Due to small space at lid, use a brush or similar item to grease with.
2. Mount the filter onto the recess (do not grease) in the lid/filter guide.
3. Turn the two locks (C) inwards to lock the filter to the lid.
4. Place the filter/filter lid into housing and screw the lid until it hits the stop.

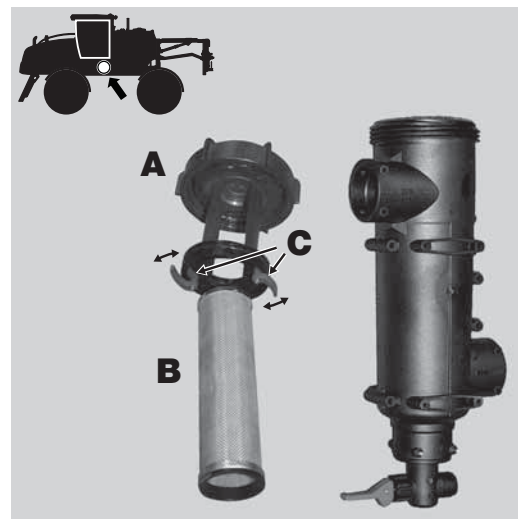

**DANGER!** The CycloneFilter must not be opened when the pressure valve is set to "Boom spraying". Otherwise, contaminated spray liquid can escape and drain from the tank.



**WARNING!** Always wear protective clothing and gloves before opening the filter!

### Hydraulic oil level

A visual gauge is located on the side of the hydraulic reservoir. Periodically check the hydraulic oil level.

- F: Float level
- N: Normal oil level
- M: Minimum oil level



ATTENTION! Always check hydraulic oil level with boom unfolded and lowered for accurate reading.



WARNING! The oil level gauge is equipped with a low oil sensor. To avoid any risk of damage to the hydraulic components, immediately stop the self-propelled sprayer and shut off the engine if the low oil warning indicator alarm goes off.

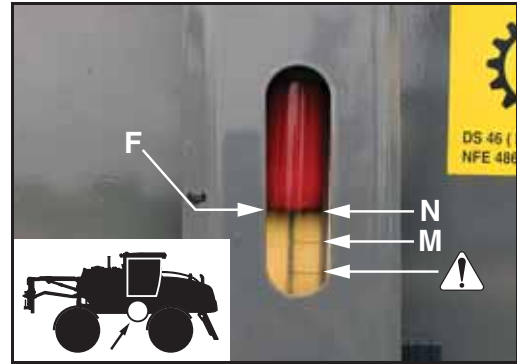

### Filling the hydraulic oil reservoir

The hydraulic reservoir has a capacity of 45 gallons (170 L). Thoroughly clean the cap (A) to prevent the introduction of impurities into the tank. Remove cap (A) with supplied 22mm hex key (HARDI® part # 28085903). Use a filter when filling with a funnel. Keeping the hydraulic system clean is imperative for long service life.

A male quickfill coupler (B) is also available for filling. Thoroughly clean coupler before use and replace dust cap when finished.



ATTENTION! Always check hydraulic oil level with boom unfolded and lowered for accurate reading.



ATTENTION! Never mix different hydraulic fluids from different manufacturers. The PRESIDIO leaves HARDI® filled with Chevron Rando® HDZ ISO 046 hydraulic oil.

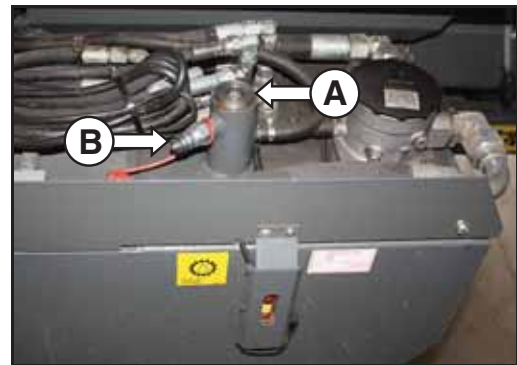

### Hydraulic oil filter replacement

Before service, stop the engine and let the machine cool down. Clean area before doing any work on this assembly. Keeping the hydraulic system clean is imperative for long service life.

- Unscrew and remove the filter cover (1).
- Remove the strainer filter assembly (2) using its metal handle.
- Check the cleanliness of the strainer filter (3). Replace if necessary with HARDI® part #PR-HE0004-03.
- Remove the main filter (4) using its metal handle (if outer metal sleeve comes out with filter, separate the two and replace sleeve).
- Replace the main filter (4) with HARDI® part # PR-HE0025. Make sure top and bottom o-rings are lubricated with clean oil.
- Replace the strainer filter assembly in its original location.
- Thoroughly clean the filter cover (1), then screw it back on.
- Check the oil level.



This filter is fitted with an electrical clogging indicator sensor. In severe cold, it is possible for the clogging indicator lamp (PRESIDIO instrument panel) to remain lit even after changing this filter. Leave the engine running at 1800 rpm and travel forward very slowly for 10 to 15 minutes so the heat is distributed in the hydraulic system. Once the oil warms up, the clogging indicator lamp should turn off.



## 6 - Maintenance

### Draining the hydraulic reservoir

Before service, stop the engine. The oil will drain more freely if the oil is still warm after running.



**WARNING!** Hydraulic oil can reach very high temperatures. To avoid severe burns, allow hot oil to cool to a warm, safe temperature. Wear protective gear to avoid contact with hydraulic oil (i.e. gloves, goggle/face shield, boots, etc.)

Oil is drained by removing plug (A). Recover used oil in a suitable container for recycling.

Clean the plug before replacing it.

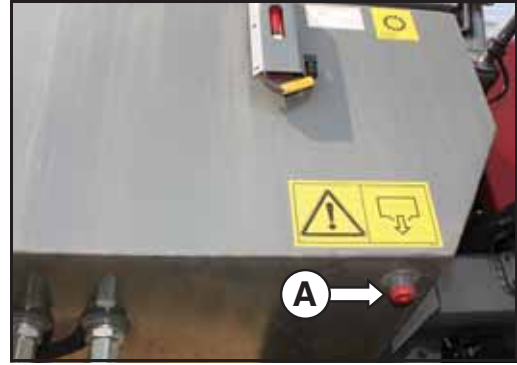

### Hydraulic hoses

Inspect the hydraulic hoses regularly. Replace any damaged or leaking hoses with exact equivalent. Examine crimped ends for reference numbers for positive identification.



**DANGER!** Hydraulic leaks: Never use your fingers to locate a leakage in any part of the hydraulic system. Due to high pressure, hydraulic oil may penetrate the skin.



**WARNING!** Before service, stop the engine and let the machine cool down. De-pressurize the hydraulic circuits before connecting or disconnecting any hoses. Tighten all connectors before starting the engine or putting the circuits under pressure.

### Air reservoir

The air tank is intended for the pneumatic suspension of the vehicle.

- Hydraulic test every ten years, and have an exterior and interior inspection every three years.
- Daily bleed water from the air reservoir (1) by pressing up on the bleed valve (2).

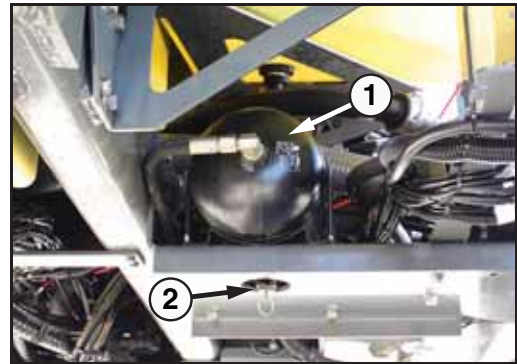

### Pneumatic suspension

The PRESIDIO is equipped with two air bags that work on the front and rear axle.

- Make daily visual inspections to check that the air bags are in good condition and are inflated.
- Ensure that the area around the two air springs is kept clean and free of oil and contaminants.

Any service work on the pneumatic system must be done by your approved HARDI® dealer.





### Cleaning the radiator

Before service, stop the engine and let the machine cool down. Open the hood of the PRESIDIO by pulling on the handle at the bottom front of the hood.

 Note: The hood is held closed by friction between rubber components (pull hard if necessary).



The radiator swivels out for cleaning. Unlock latch at bottom, left corner with a large screwdriver. Then pull radiator out to cleaning position.



Use compressed air or low pressure water jet to clean radiator.

 **WARNING!** Do not use high pressure water jet on radiator components.



### Hood side panels

The hood side panels may be removed for cleaning or to access engine components.

With a large screwdriver, turn latches at bottom of hood to release. Pull bottom out to free panels.

When replacing panels, line up the two pins at the top first. Then position the bottom of the panels into their proper location. Turn latches in opposite direction to lock into place.

 Note: A U.S. quarter works well to turn latches (if more convenient than a large screwdriver).



## 6 - Maintenance

### Activated carbon filters (cabin)

The filters are important for the cleanliness of the cabin environment. Before operator enters cabin, it is recommended to remove any contaminated clothing, boots, etc. This will extend the operating life of the filters and, more importantly, keep the operator more comfortable and safe.

Remove filter hood (2) by unscrewing retaining screws (1).

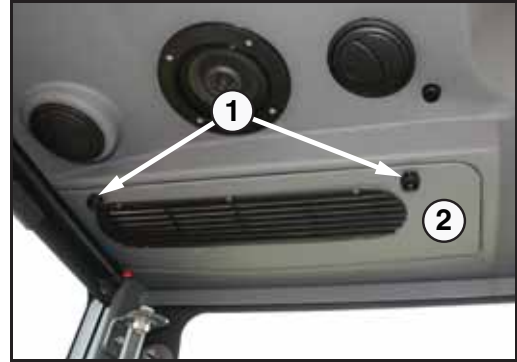

Turn filter support (3) to allow for removal of filters.



ATTENTION! Note location of temperature sensor (A) while removing filters. Avoid moving or damaging sensor when re-installing filters.

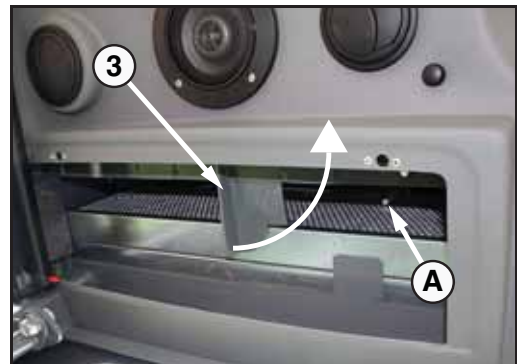

Remove charcoal filter (4), then paper filter (5). Replace with new filters (HARDI® part # PR-CA8889) in same order. Note notch in upper front corner of filters when re-installing.



ATTENTION! Take care not to move or damage temperature sensor when re-installing filters (see previous illustration).

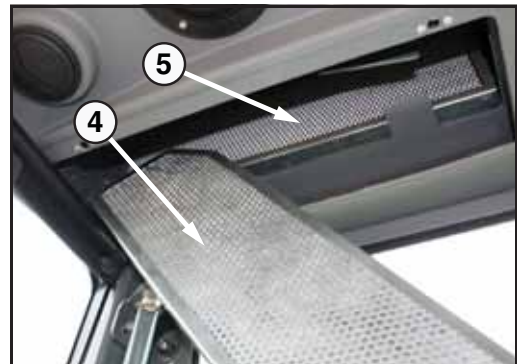

### Checking the efficiency of the brakes

- Load the vehicle.
- Start the vehicle and accelerate to its maximum speed.
- Press down the brake pedal fully.

Braking distance: approximately 21 yards (19 m).

### Checking the efficiency of the parking brake

- Load the vehicle
- Place the vehicle on a slope at maximum 18%.

The vehicle must remain stopped.



### Towing the vehicle

The rear wheel motors of the unit are fitted with inboard, spring applied, hydraulically released wet disc brakes. In the event of a blown hydraulic hose or an engine failure, the static brakes will apply.

In an emergency, it may be necessary to tow the vehicle a short distance. In order to tow the vehicle, it will be necessary to uncouple the drive reduction from the brakes.



**WARNING!** Use caution to avoid possible hot metal or oil. Reduction gear and oil may be very hot.

### Procedure for uncoupling drive

Connect the equipment to the towing vehicle using a towing bar. The towing bar is required as the static parking brakes are disconnected when the gear is removed. Clean the plug area of the rear wheel motor and remove the threaded plug (1). Use a 24mm Hex Key (HARDI® part # 28086003 supplied with the machine). Recover any oil that may come out in a suitable container for recycling.



Completely remove the shaft from the planet gear (2) of the reduction gear using an M8 threaded bolt (3) long enough to reach (e.g. HARDI® part # 420847 M8X85 mm).



Before towing, fill the reduction gear with oil and replace plug (1).

The uncoupled drive is used only to tow the vehicle over a short distance. Check that you do not exceed 2 mph (3 km/h). Before removing the towing bar, replace the shaft in the reduction gear or take suitable measures so that the machine does not start rolling (i.e. chock the wheels).

### Procedure for coupling drive

Make sure vehicle cannot start rolling (connect to towing bar or chock wheels).



**WARNING!** Use caution to avoid possible hot metal or oil. Reduction gear and oil may be very hot.

- Clean the area. Remove the threaded plug (1).
- Recover any oil that may come out in a suitable container.
- Insert the shaft of the planet gear (2) in the reduction gear.
- Before starting, fill the reduction gear with oil and replace the threaded plug (1).
- Before removing the towing bar, take suitable measures (i.e. chock the wheels of the sprayer so the machine does not roll before you are sure the brake system is operating).

## 6 - Maintenance

### Maintaining reduction gear of rear wheel motor

Before service, stop the engine.

- Perform weekly visual inspections.
- Check the tightness of the reduction gear.
- Regularly ensure that the reduction gear does not emit suspicious noises.
- Regularly check the oil level.

### Draining the reduction gears

Always drain the oil when it is warm after the reduction gear is shut down. The oil will drain more freely if the oil is still warm after running.



**WARNING!** Allow very hot reduction gear and oil to cool to a warm, safe temperature before servicing.

The draining of the reduction gears is done from plug (2). Open plug (1) with 24mm Hex Key to facilitate flow (HARDI® part # 28086003 supplied with the machine). Recover used oil in a suitable container for recycling.



**Note:** Plug (2) must be oriented at the bottom of the reduction gear directly below plug (1).

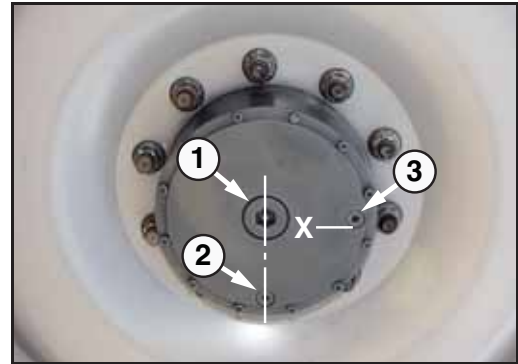

### Filling the reduction gears

Use only SAE 80W-90 multi-purpose gear lubricant.

- Replace bottom plug (2).
- Fill from plug port (1) until oil begins to run out of the plug port. Replace top plug (1).
- In order to add oil to the correct level (X), remove plug (3) and continue adding oil through the plug port until oil begins to run out.
- Replace plug (3).

### Maintaining boom paralift

During storage or maintenance of the PRESIDIO, you must move both the left and right lock arms from position (A) to position (B).

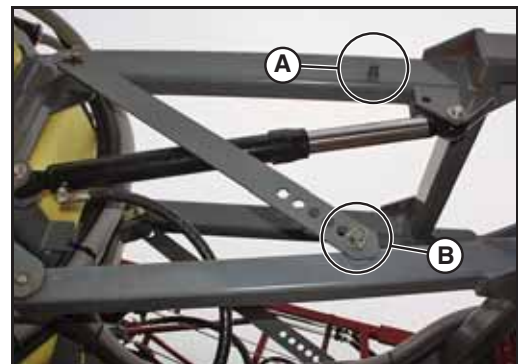

It is essential to pay special attention to the tanks, piping and hydraulic accumulator. They must not be subjected to any chemical, thermal or mechanical attack. They must be kept in a good state of cleanliness and free of all corrosion and all visible flaws.

If there is any doubt regarding the integrity of any of these components, immediately seek the advice of your authorized HARDI® dealer.



**ATTENTION!** The hydraulic accumulator must be checked every three years and replaced every ten years.



### Greasing the frame

Grease fittings 1, 2 & 3 on both sides of the front axle.

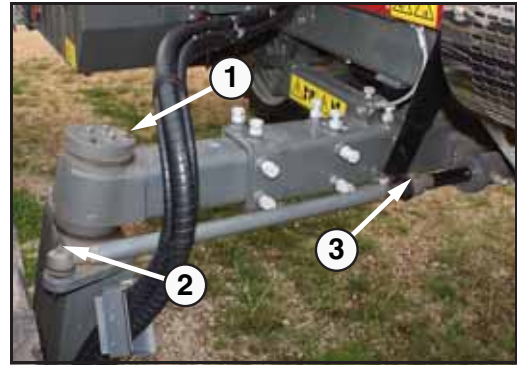

Grease fittings 4 & 5 on both sides of the rear parallelogram arms.

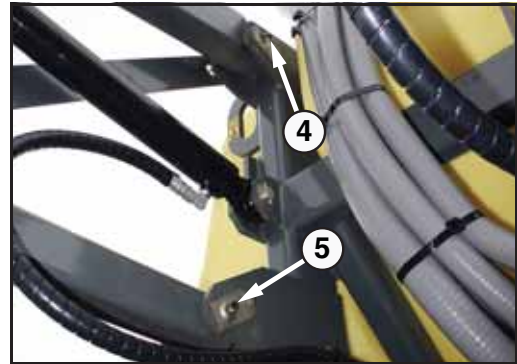

Grease fittings 6 & 7 above rear axle.

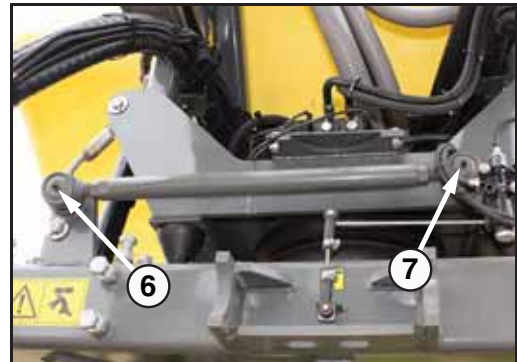

Grease fittings 8 & 9 on both sides at rear of vehicle.

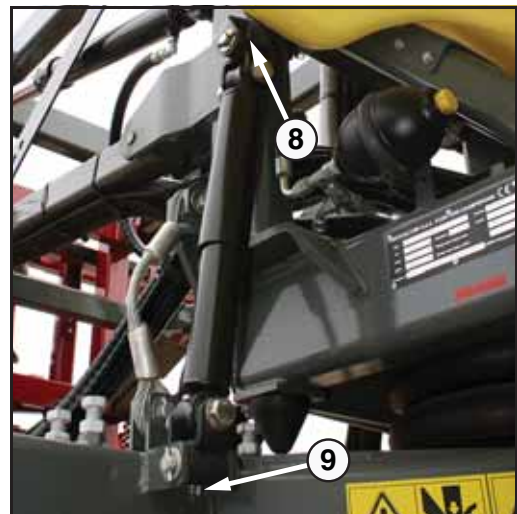

## 6 - Maintenance

---

### Engine maintenance

---

#### Before starting every day

All work that is done on the engine must be carried out when engine is cool, parking brake is on, ignition off and battery isolation switch off. Before any service, stop the engine and let the machine cool down (unless otherwise noted).

- Check the level of all fluids; fuel, engine oil, coolant.
- Make sure the air filter is not clogged.

---

#### Periodic engine maintenance

Avoid operating the engine with a nearly empty fuel tank to prevent:

- Risk of condensation forming inside tank.
- Risk of system losing its prime.

Regularly check the cleanliness of the air inlet system (and the exhaust).

Periodically verify the charge of the battery and top up the electrolyte level if required.

---

#### Engine oil level

Check on level ground when the engine is stopped and cold.

The oil level should be between minimum and maximum on the dipstick gauge.



If oil needs to be added, remove the right side hood panel (See "Hood side panels" on page 77) to access engine oil filling cap (B).

Refill with oil (See "Table of recommended lubricants" on page 71).

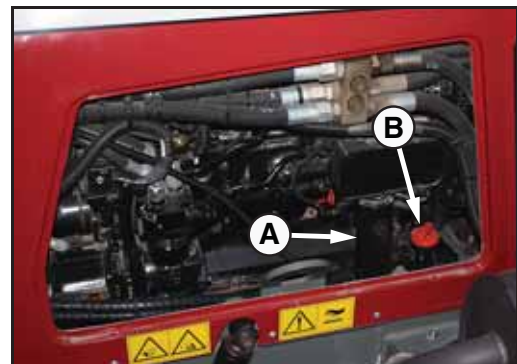

### Coolant level

Open the hood of the PRESIDIO by pulling on the handle at the bottom front of the hood.



Note: The hood is held closed by friction between rubber components (pull hard if necessary).



Check coolant level using the peep sight near the top of the radiator. The coolant level should be in the middle of the sight when the engine is cool.



The radiator cap is accessed by a hole in the top center of the hood.



**WARNING!** Never open radiator cap when engine is hot. Always allow engine to cool completely first.





## 6 - Maintenance

### Engine air filter maintenance

The air filter is a dual element dry type.

Remove any dust from the discharge valve (C) by squeezing the sides as shown by the arrows. Make sure no dust enters the sleeve. Clean the discharge slot occasionally.

Remove the outer cover (A) by removing the wing nut (B).

Remove the primary filter cartridge (D). Clean the cartridge with a jet of dry, compressed air directed from the inside outwards. Air pressure must not exceed 75 psi (5 bar).

Before replacing the cartridge, check for damage to the filter paper by shining a light through it. Also check for damage to the seal.

Replace with new filter as per the schedule or sooner if needed.

Use HARDI® part # PR-MA0014 to replace outer primary filter cartridge.  
Use HARDI® part # PR-MA0015 to replace inner security filter cartridge.



**ATTENTION!** Never clean the inner security cartridge! Visually inspect for damage when cleaning the outer primary cartridge. Replace with new filter as per the schedule or sooner if needed.



### Water separator (fuel system)

The water separator in the fuel system is located at the front of the sprayer and should be checked daily. Access is behind front hood. Unscrew the drain screw (D) and let any water contained in the separator flow out.

Re-tighten the screw.

If there is an audible alert and warning message on the Deutz display, drain the filter immediately.

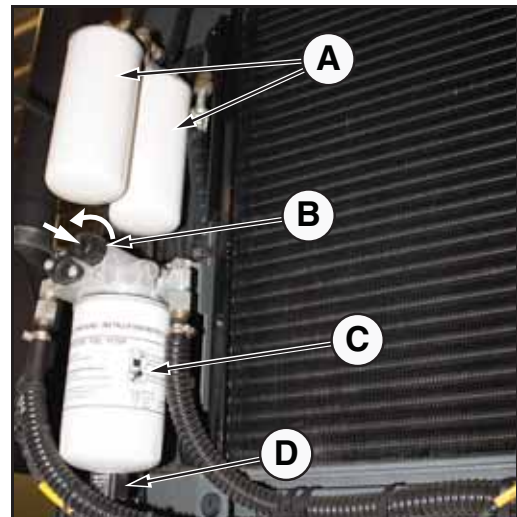

**DANGER!** Only work on the fuel system when the engine is switched off.



Diesel fuel is extremely flammable. Handle with care. Do not smoke or expose fuel to open flame. It is recommended for the operator to install a fire extinguisher in a place that is easily accessible and checked regularly.

### Replacing the water separator element

The pre-filter cartridge (C) needs to be replaced with HARDI® part # PR-MA0342-02 as per the schedule.

- Follow the wire from the drain screw (D) and disconnect plug from wiring harness (near pre-filter).
- Place a small container below the pre-filter to collect any fuel which may run out.
- Unscrew cartridge (C) to remove along with drain screw sensor (D).
- Clean the sealing surface of the filter housing.
- Wet the seal on the new pre-filter cartridge lightly with diesel fuel.
- Screw the new filter on by hand until the seal makes contact. Tighten an additional three-quarter turn.
- Connect the sensor wire to the wiring harness plug (near pre-filter).

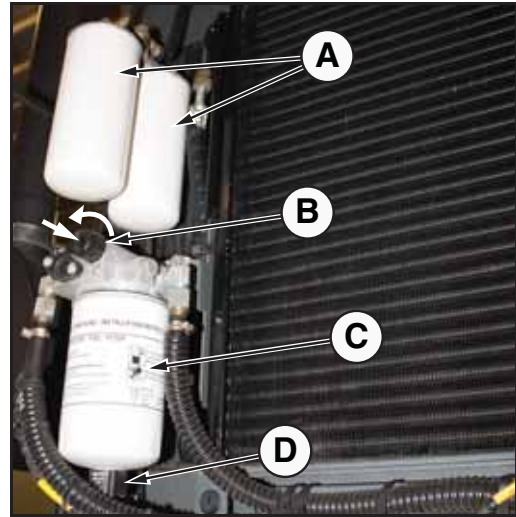

**i** Note: Fuel system must be primed after replacing filter.

### Fuel system priming

Unlock the bayonet plug of the fuel hand pump (B) by pressing and turning counter-clockwise. The pump plunger will extend. To prime the fuel system, pump until a very strong resistance is felt and pumping becomes slow. Pump a few more times to fill the return pipe. Start the engine and run for about 5 minutes at idle.

Lock the bayonet plug of the fuel hand pump (B) by pressing and turning clockwise.

### Replacing the fuel filters

The PRESIDIO has two fuel filter elements (A) (HARDI® part # PR-MA0237-04). These should be replaced as per the schedule. It is always recommended to use genuine filters.

The elements are removed as shown.

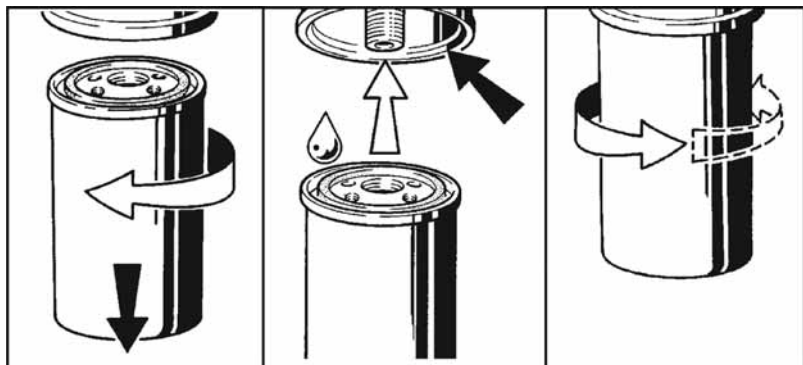

Use a small bucket or tray to collect any fuel which may run out. Clean the sealing surface of the filter housing. Lightly oil the new filter or wet with diesel fuel. Screw the new filter on by hand until the seal makes contact. Tighten an additional three-quarter turn.

**i** Note: Fuel system must be primed after replacing filters.

**!** DANGER! Only work on the fuel system when the engine is switched off.

**!** Diesel fuel is extremely flammable. Handle with care. Do not smoke or expose fuel to open flame. It is recommended for the operator to install a fire extinguisher in a place that is easily accessible and checked regularly.

## 6 - Maintenance

### Bleed fuel tank

The fuel tank should be completely drained every 1000 hours (and after first 80 hours) to remove any water/impurities from the bottom of the tank. This should be performed when the fuel tank is nearly empty.

- Remove the fuel tank drain (A) and allow fuel to drain completely.
- Recover fuel in a suitable container for disposal.
- Clean the plug before replacing it.

 **ATTENTION!** Do not attempt to re-use fuel.

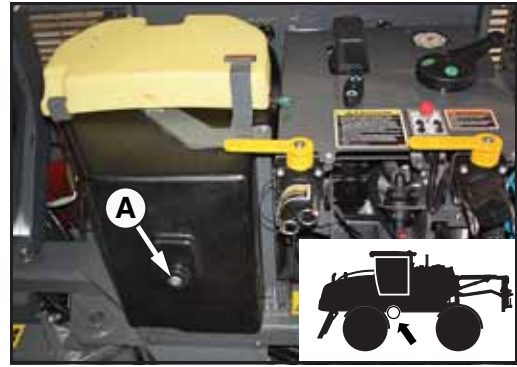

### Engine oil and filter change

The engine oil and filter should be changed as per the schedule. Before service, stop the engine. The oil will drain more freely if the oil is warm (after running).

- Oil is drained by removing plug (1).
- Recover used oil in a suitable container for recycling.
- Clean the plug before replacing it.

 **WARNING!** To avoid severe burns, allow hot oil to cool to a warm, safe temperature.

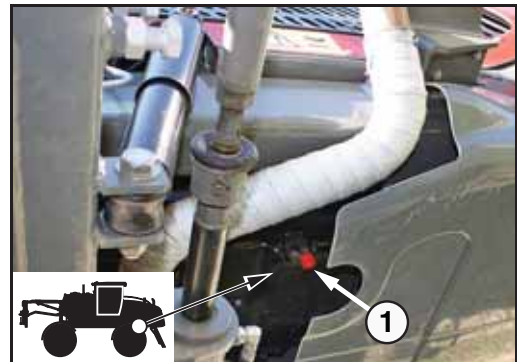

Remove the right side hood panel (See "Hood side panels" on page 77) to access engine oil filter (A) (HARDI® part # PR-MA0009) and engine oil filling cap (B).

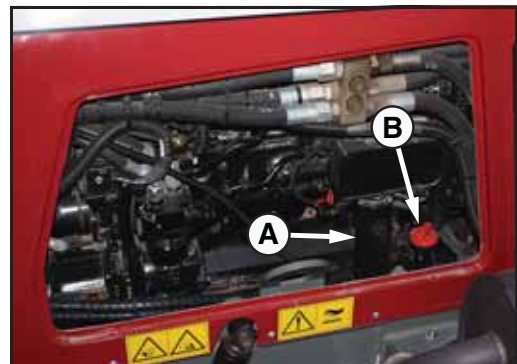

Remove engine oil filter (A) as shown.

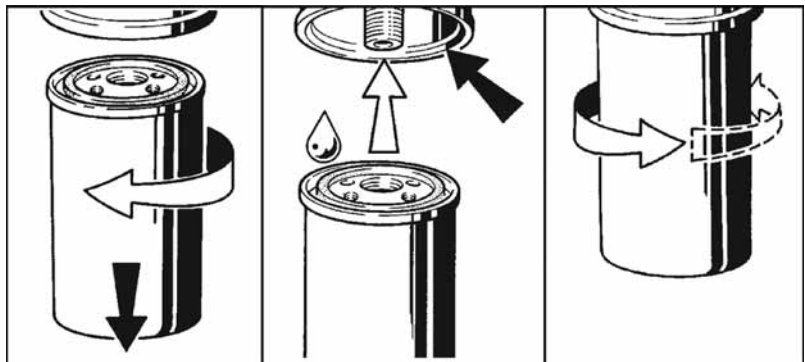

Recover used oil in a suitable container for recycling. Clean the sealing surface of the filter housing. Lightly oil the new filter. Screw the new filter on by hand until the seal makes contact. Tighten an additional three-quarter turn.

Refill with oil (See "Table of recommended lubricants" on page 71).



### Occasional maintenance

#### General information

The maintenance and replacement intervals for the following will depend very much on the conditions under which the sprayer is operated and are therefore impossible to specify.

#### Air nozzle

The PRESIDIO is equipped with a simple air nozzle for the purpose of cleaning nozzles, etc. The line connects to the air system on the left side of the machine in the working area.

- Periodically inspect hose and nozzle for damage or leaks.

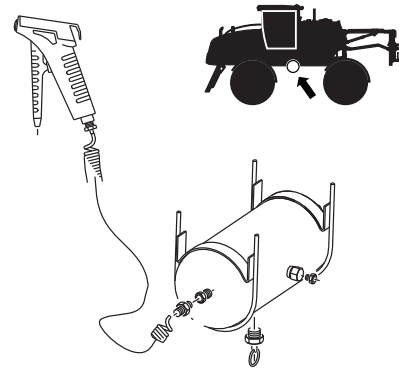

#### Air regulator on run dry fluid pump

The reservoir pressure regulator is factory preset to 30 psi. Pressure may increase during operation as the fluid is heated. Periodically check the reservoir pressure gauge to make sure it is in the green range.



Note: Air tank must be fully pressurized (i.e. engine running) for accurate reading.



#### HARDI® run dry fluid pump

Check the barrier fluid level in the pump by checking the sight gauge window (1) on the side of the seal reservoir (the fluid is clear - look for floating colored ball).

If fluid is not visible, add fluid by following these steps:

- With engine shut off, bleed air from air tank (See "Air reservoir" on page 76).
- Disconnect red air line and remove plug/pressure gauge assembly.
- Add barrier fluid (HARDI® part # 29004303) until level is at top edge of sight gauge window (do not overfill).
- Replace plug/pressure gauge assembly. Re-connect air line.



The pressure regulator will pressurize when the PRESIDIO is started again. Check to make sure it is in the green range.

## 6 - Maintenance

### Generator and battery

The PRESIDIO battery is located on the right side of the machine between the hydraulic tank and frame. Keep battery connections clean.

Never disconnect the battery or place the battery isolation switch to "OFF" while the engine is running.

Before welding anywhere on the PRESIDIO frame, disconnect the battery and generator.

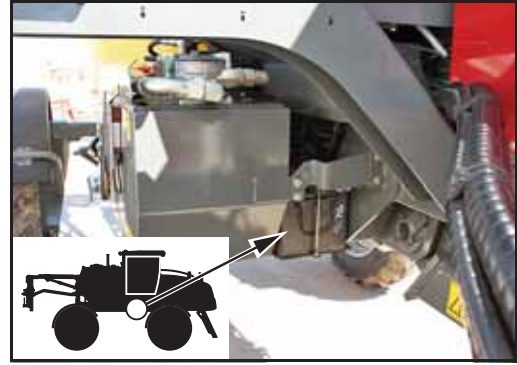

The generator (A) can be accessed by removing the right side hood panel (See "Hood side panels" on page 77).



### Check the electrolyte level of the battery

When the battery is not in use and cold, check that the electrolyte level is located between the max and min readings. If the level is below minimum, then top up with distilled water. Check more often in the summer. If the engine is not used for a lengthy period, then check the electrolyte level at least once. Check that the battery terminals are clean, tight and protected by a coating of corrosion prevention spray or grease.



Note: For replacement battery, use HARDI® part # PR-EA0008.



WARNING! Either remove the battery or turn the battery isolation switch to OFF before charging the battery to avoid damaging the PRESIDIO electronics.

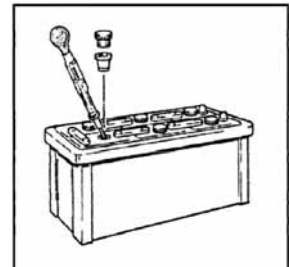

### Cone check/replacement for EFC distribution valve

Periodically check the distribution valves for proper sealing. Do this by running the sprayer with clean water and open all distribution valves. Cautiously remove the clip (1) and pull out the hose (2) for the return line. When the housing is drained, there should be no liquid flow through the return line. If there is any leakage, the valve cone (5) must be changed. Remove the clip (3) and lift the motor housing off the valve housing. Then unscrew the screw (4) and replace the valve cone (5). Reassemble in reverse order.

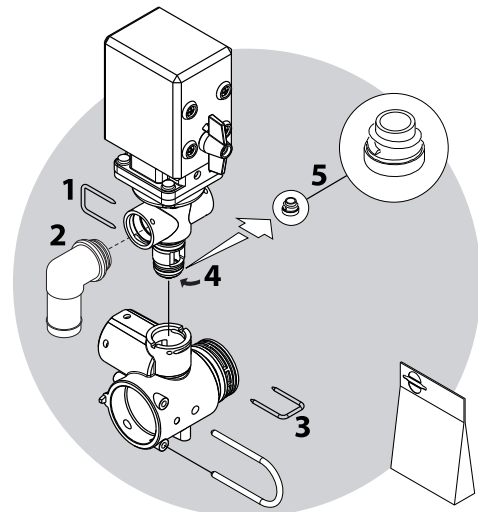

### Level indicator adjustment

The level indicator reading should be checked regularly. When the tank is empty, the float should lie on the stop pin (D) of the rod, and the O-ring on the indicator should be positioned at the top position line (A).



ATTENTION! The wire guide wheels should be directed so they follow the direction of the wire.

If any deviation is found:

1. Pull out the plug (B).
2. Loosen screws (C).
3. Adjust the length of the cord until it reads correctly.
4. Push plug (B) back in place.

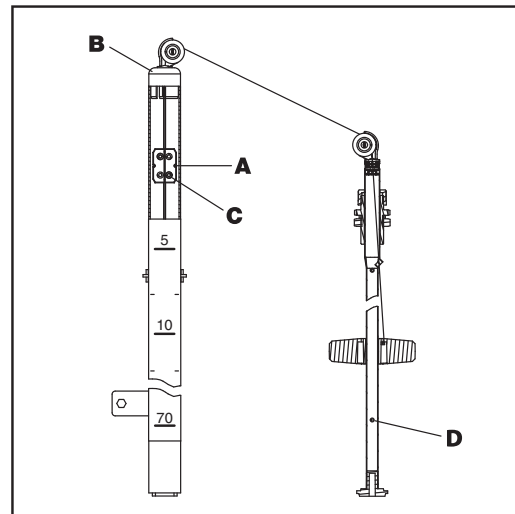

### Level indicator wire replacement

If the wire on the level indicator has to be changed, the float guide pole is removed:

1. Remove the tank drain valve (See "Drain valve seal replacement" on page 89) and loosen the fitting holding the pole in position.
2. Pull the pole down through the drain valve hole until it is free in the top of the tank.
3. The pole can now be taken out of the tank through the filling hole.



DANGER! Do not enter the inside of the tank - the parts can be changed from the outside of the tank!

### Drain valve seal replacement

If the main tank drain valve leaks, the seal and seat can be changed the following way.



DANGER! Do not enter the inside of the tank - the parts can be changed from the outside of the tank!



WARNING! Use eye / face protection mask when dismantling the tank drain valve!

1. Make sure the tank is empty and clean.
2. The valve must be closed and the string loose.
3. Pull out the clip (A) and pull down connecting piece (B). The entire valve assembly can now be pulled out.
4. Check cord and valve flap assembly (C) for wear, replace seal (D) and assemble again.
5. Assemble the valve assembly again using a new valve seat (E). Lubricate O-rings (F) before assembly.
6. Fit clip (A) again.

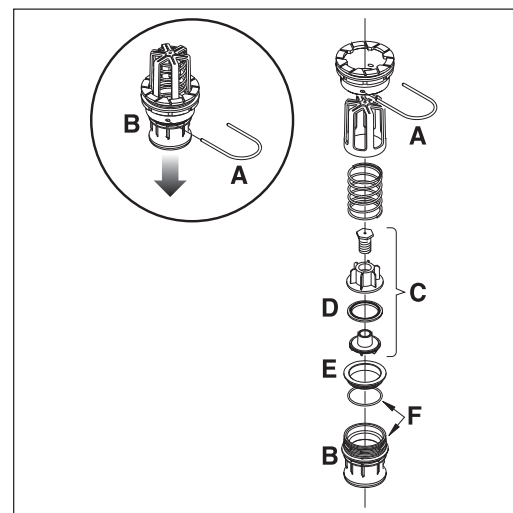

ATTENTION! Check function of valve with clean water before filling chemicals into the tank.

## 6 - Maintenance

### Adjustment of 3-way-valves

If a 3-way valve is difficult to turn or if it turns too easily or there is a risk of leak, the serrated washer can be adjusted as shown in the picture.



Note: This procedure is also valid for electric valves.

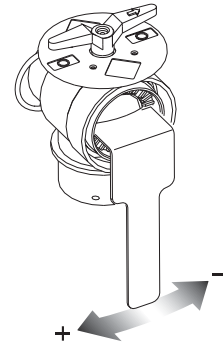

### Filling filter removal/cleaning

To service the filling filter:

1. Remove cap from "MAIN" quick fill coupler and open the "MAIN" tank filling valve to drain any excess water from the filling line.
2. Remove drain plug (A) to drain filter housing lid before removal.
3. Remove nut (B) to remove filter housing lid (C).
4. Clean and inspect filter. Inspect and grease O-ring (D) in filter housing lid before replacing.
5. Replace filter, lid (C), nut (B) and drain plug (A).
6. Close "MAIN" tank filling valve and secure cap to quick fill coupler.

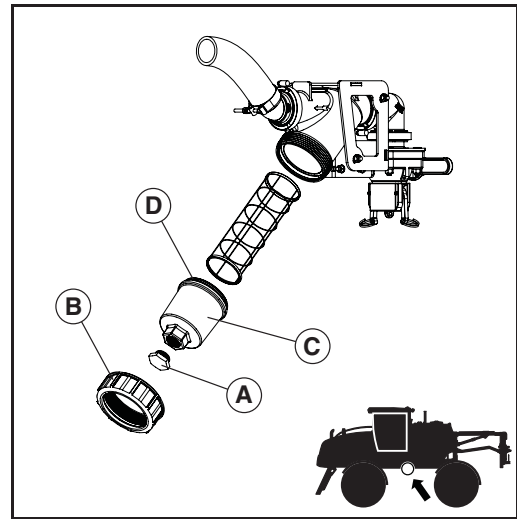

**DANGER!** If filling line has been contaminated with chemicals (i.e. used to fill pre-mixed solution), wear appropriate personal safety equipment when removing filter (See "Safety precautions - crop protection chemicals" on page 62).



**ATTENTION!** When finished with sprayer for the season, make sure to drain excess water from line and filter housing to prevent damage from freezing temperatures.

### Replacing the brake discs

Any service work on the braking system (hydrostatic or friction braking, dynamic or static) needs to be carried out by an authorized HARDI® Dealer.

### Brake accumulator

The brake accumulator is located on the right side of the sprayer underneath the cab (behind the hydraulic tank). It must be kept in a good state of cleanliness and free of all corrosion and all visible flaws.

Any service work on the brake accumulator needs to be carried out by an authorized HARDI® Dealer.



**ATTENTION!** The brake accumulator must be checked every 250 hours and replaced every 5 years.

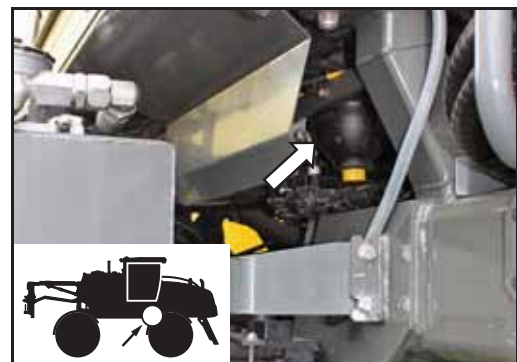

### Off-season storage

---

#### Off-season storage program

When the spraying season is over, you should devote some extra time to the sprayer. If chemical residue is left over in the sprayer for longer periods, it can reduce the life of the individual components. To preserve the sprayer intact and to protect the components, carry out following off-season storage program.

1. Clean the sprayer completely - inside and outside - as described under "C: Full internal cleaning (Soak wash)" on page 68. Make sure that all valves, hoses and auxiliary equipment have been cleaned with detergent and flushed with clean water afterwards, so no chemical residue is left in the sprayer.
2. Replace possible damaged seals and repair possible leaks.
3. Empty the sprayer completely and let the pump work for a few minutes. Operate all valves and handles to drain as much water off the spraying circuit as possible. Let the pump run until all nozzles stop spraying. Remember to drain the flush tank also.
4. Pour appr. 13 gal. (50 liters) of anti-freeze into the main tank. This will mix with the remaining water in the fluid system to create a protective ratio of anti-freeze/water solution.
5. Engage the pump and operate all valves and functions, operating unit, chemical inductor etc. allowing the anti-freeze mixture to be distributed around the entire circuit. Open the operating unit main on/off valve and distribution valves so the anti-freeze is sprayed through the nozzles as well. The anti-freeze will also prevent O-rings, valves, seals etc. from drying out.
6. Lubricate all lubricating points according to the lubricating scheme - regardless of intervals stated.
7. When the sprayer is dry, remove rust from possible scratches or damages in the paint and touch up the paint.
8. Remove the glycerin-filled pressure gauges and store them frost free in vertical position.
9. Apply a thin layer of anti-corrosion oil (e.g. SHELL ENSIS FLUID, CASTROL RUSTILLO or similar) on all metal parts. Avoid oil on rubber parts, hoses and tires.
10. Fold the boom in transport position and relieve pressure from all hydraulic functions.
11. Drain compressed air tank to avoid condensation (See "Air reservoir" on page 76).
12. Drain excess water from filling filter hose and filter housing to prevent damage from freezing (See "Filling filter removal/cleaning" on page 90).
13. All electric plugs and sockets are to be stored in a dry plastic bag to protect them against damp, dirt and corrosion.
14. Remove the control boxes and computer display from the cab, and store them dry and clean (in-house). A non-condensing environment is recommended.
15. Apply grease on all hydraulic ram piston rods which are not fully retracted in the barrel to protect against corrosion.
16. Chock up the wheels, to prevent moisture damage and deformation of the tires. Tire blacking can be applied to the tire walls to preserve the rubber.
17. To protect against dust, the sprayer can be covered by a tarpaulin. Ensure ventilation to prevent condensation.

---

#### Preparing the sprayer for use after storage

After a storage period, the sprayer should be prepared for the next season the following way:

1. Remove the cover.
2. Remove the support from the wheel axle and adjust the tire pressure.
3. Wipe off the grease from hydraulic ram piston rods.
4. Fit the pressure gauges again. Seal with Teflon tape.
5. Check all hydraulic and electric functions.
6. Empty the tank of remaining anti-freeze.
7. Rinse the entire liquid circuit on the sprayer with clean water.
8. Fill with clean water and check all functions.



## 7 - Fault finding

### Liquid system

FAULT	PROBABLE CAUSE	CONTROL/REMEDY
No spray from boom when turned on.	Air leak on suction line. Air in system. Pressure filters clogged.	Check suction tube and fittings. Fill suction hose with water for initial prime. Clean filters.
Lack of pressure.	Incorrect assembly. Defective pressure gauge.	Boost valve is open. Check for dirt at inlet of gauge.
Pressure dropping.	Filters clogging. Nozzles worn. Tank is air tight. Sucking air towards end of tank load.	Clean all filters. Fill with cleaner water. If using powders, make sure agitation is on. Check flow rate and replace nozzles if it exceeds 10%. Check vent in tank lid is clear. Lower pump r.p.m.
Pressure increasing.	Pressure filters beginning to clog.	Clean all filters. Make sure bottom valve on CycloneFilter is not left in closed position (marked with 1 dot) after flushing boom. Operating position (marked with 2 dots) keeps CycloneFilter clean.
Formation of foam.	Air is being sucked into system. Excessive liquid agitation.	Check tightness/gaskets/O-rings of all fittings on suction side. Reduce pump r.p.m. Ensure returns inside tank are present. Use foam damping additive.
Operating unit not functioning or having malfunction.	Blown fuse(s).  Wrong polarity. Valves not closing properly.  No power.	Check mechanical function of microswitches. Use cleaning/ lubricating agent if the switch does not operate freely. Check motor. 450-500 milli-Amperes max. Change motor, if over. Brown - pos. (+). Blue - neg. (-). Check valve seals for obstructions. Check microswitch plate position. Loosen screws holding plate 1/2 turn. Wrong polarity. Check that brown is pos. (+), Blue is neg. (-). Check print plate for dry solders or loose connections. Check fuse holder is tight around fuse.



## 7 - Fault finding

### Electrical incidents

#### Fuses for circuit board EA0560

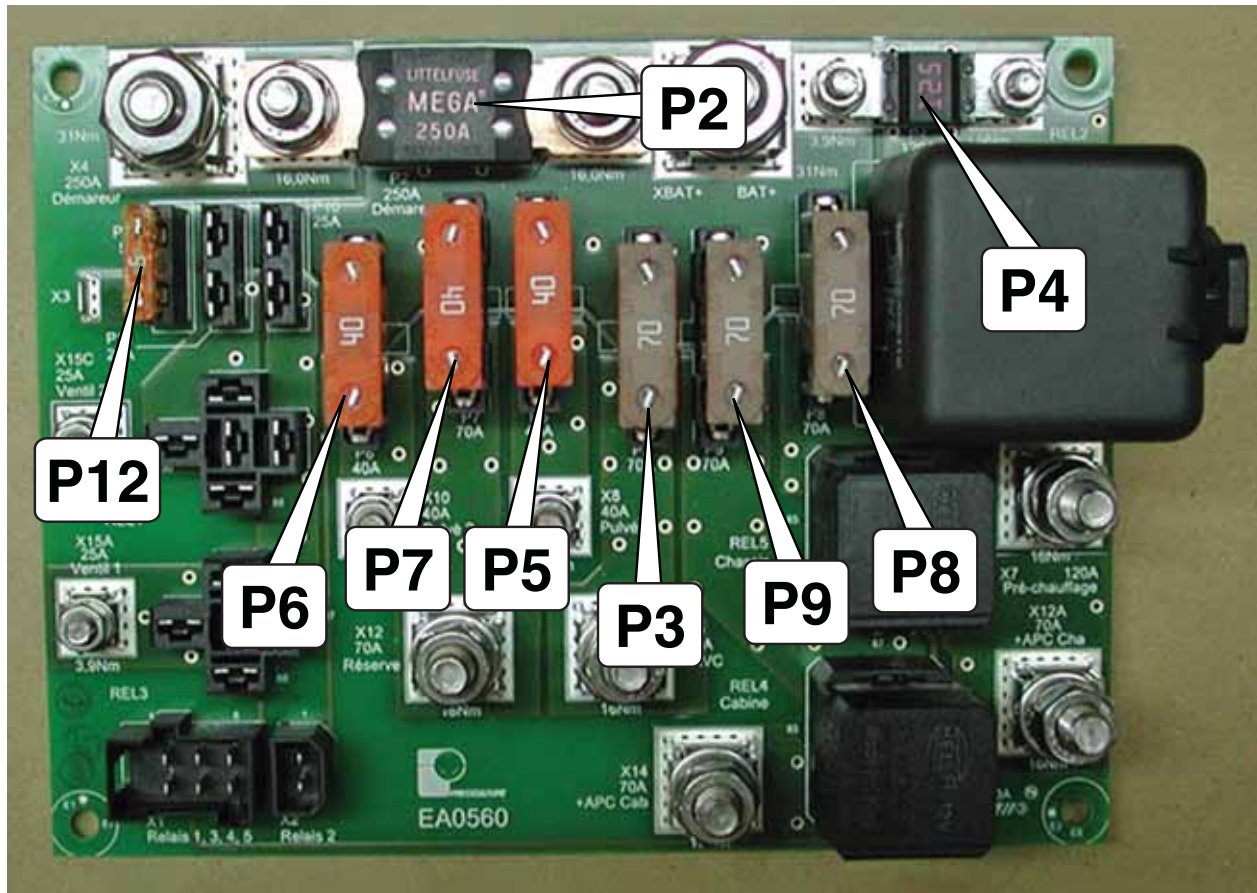

Fuse #	Amps	Description
P2	250A	Starter
P3	70A	(+) before ignition
P4	125A	Preheating
P5	40A	Spray 1
P6	40A	Spray 2
P7	40A	Free
P8	70A	(+) after ignition - Frame card
P9	70A	(+) after ignition - Cab card
P12	5A	Spray 3



### Fuses for circuit board EA0554

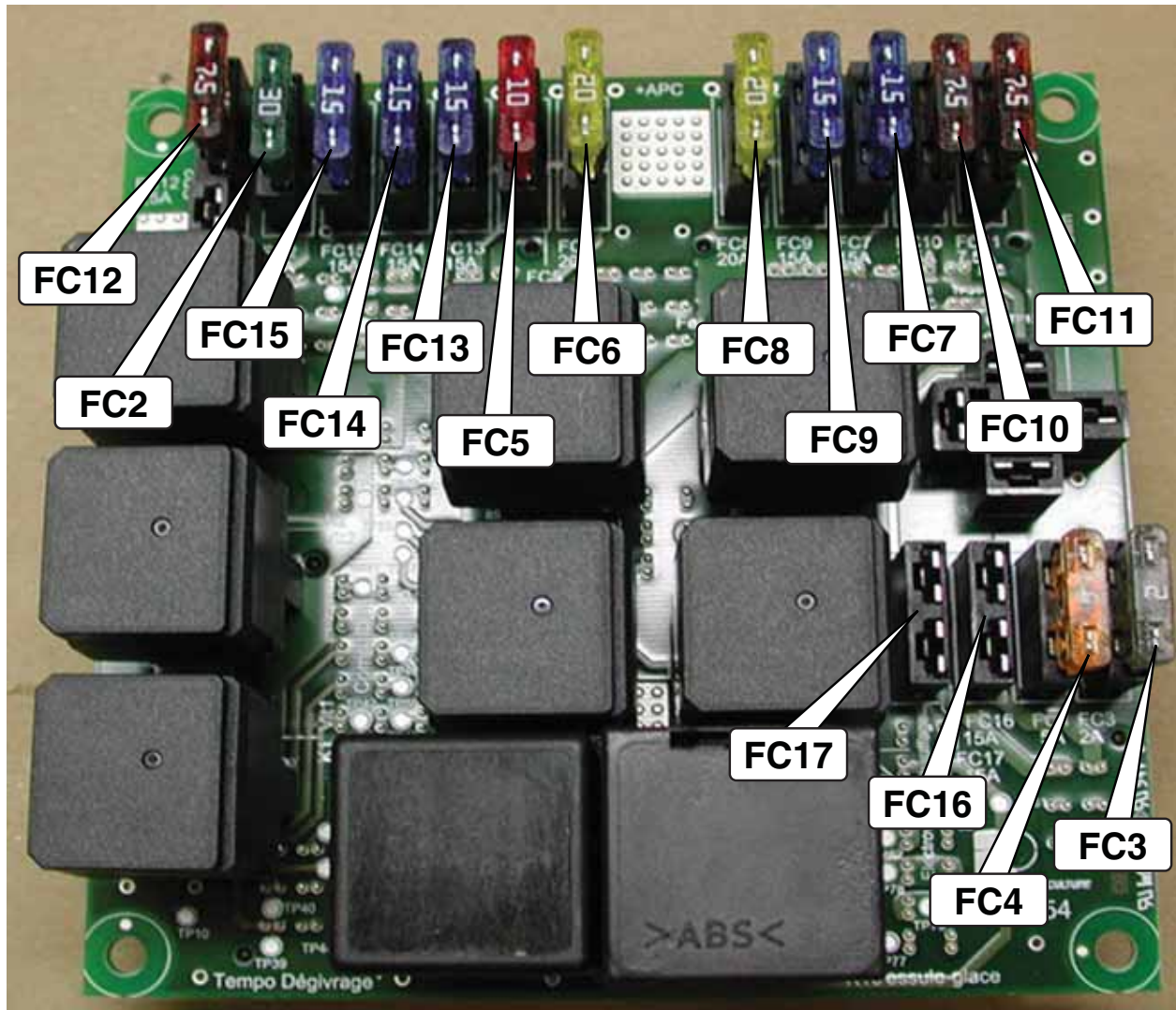

Fuse #	Amps	Description
FC2	30A	Cab ventilation
FC3	2A	Relay control (heating solenoid valve, ventilation, air conditioning compressor, power supply air conditioning regulator)
FC4	5A	Air conditioning compressor
FC5	10A	Front work light (hood)
FC6	20A	Front work light (cab roof x4)
FC7	15A	Rear work light
FC8	20A	Boom work light
FC9	15A	Wipers, washers
FC10	7.5A	Flashing beacon light
FC11	7.5A	Ceiling light, reading light, mirror electric controls
FC12	15A	Radio (Before or after ignition)
FC13	15A	Free
FC14	15A	Free
FC15	15A	Free
FC16	15A	Free
FC17	15A	Free

## 7 - Fault finding

### Fuses for circuit board EA0563

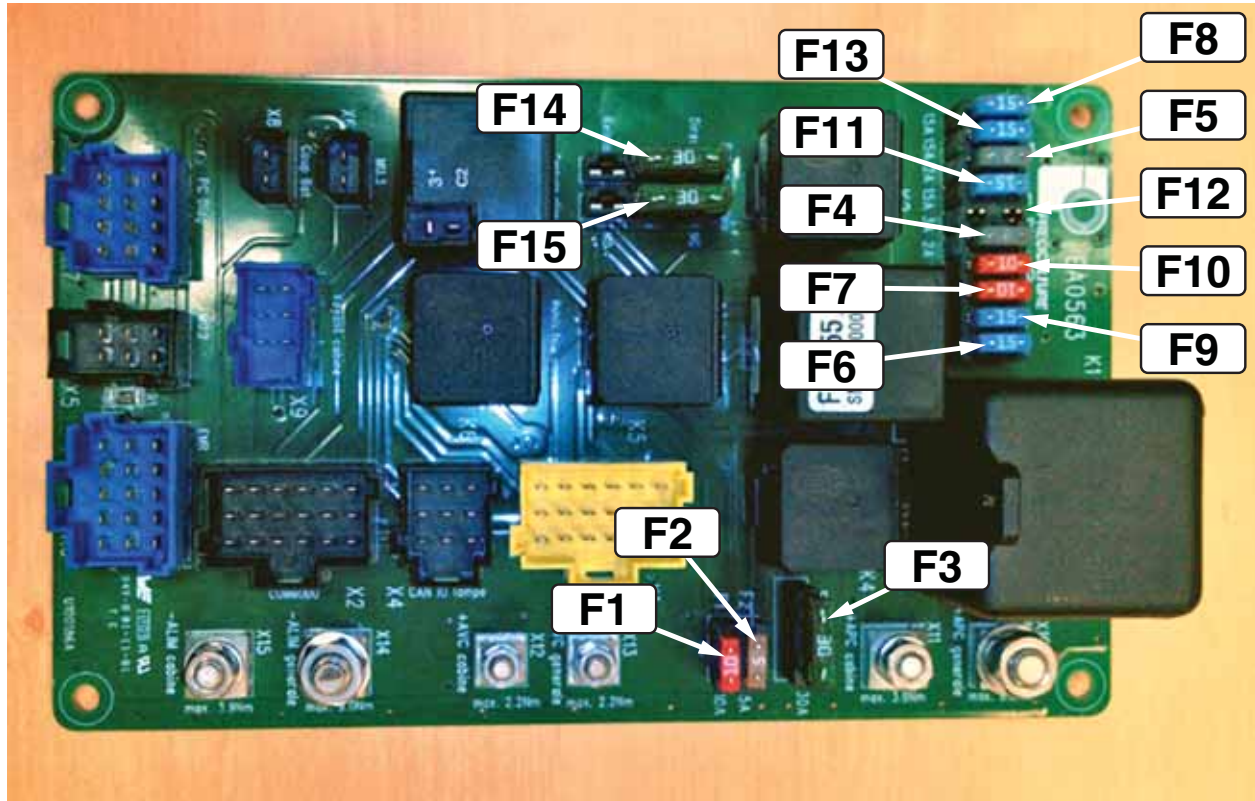

Fuse #	Amps	Description	
F1	10A	Hazard, flashing	Before battery isolation switch
F2	5A	Ignition key switch	Before battery isolation switch
F3	30A	Heat engine (power) Relay EMR -ECU Deutz	After battery isolation switch
F4	2A	Heat engine (control)	After battery isolation switch
F5	2A	Diff Lock	After battery isolation switch
F6	15A	Trailer socket	After battery isolation switch
F7	10A	Pneumatic seat	After battery isolation switch
F8	15A	Hyd. oil filter warning light + oil low lever (arm + light) + fuel sender	After battery isolation switch
F9	15A	12V power (acc)	After battery isolation switch
F10	10A	Turn signal/light switch	After battery isolation switch
F11	15A	Relay (head light power)	After battery isolation switch
F12	3A	Joystick board + PCB for frequency board signal	After battery isolation switch
F13	15A	Speed range selector and coils + Hyd. high temperature + Static brake	After battery isolation switch
F14	30A	Diff. Lock Coil - Position NO (1 & 2)	After battery isolation switch
F15	30A	Diff. Lock Relays - Position NC (1 & 2)	After battery isolation switch

## Specifications

### Dimensions

#### Presidio with SPC Boom

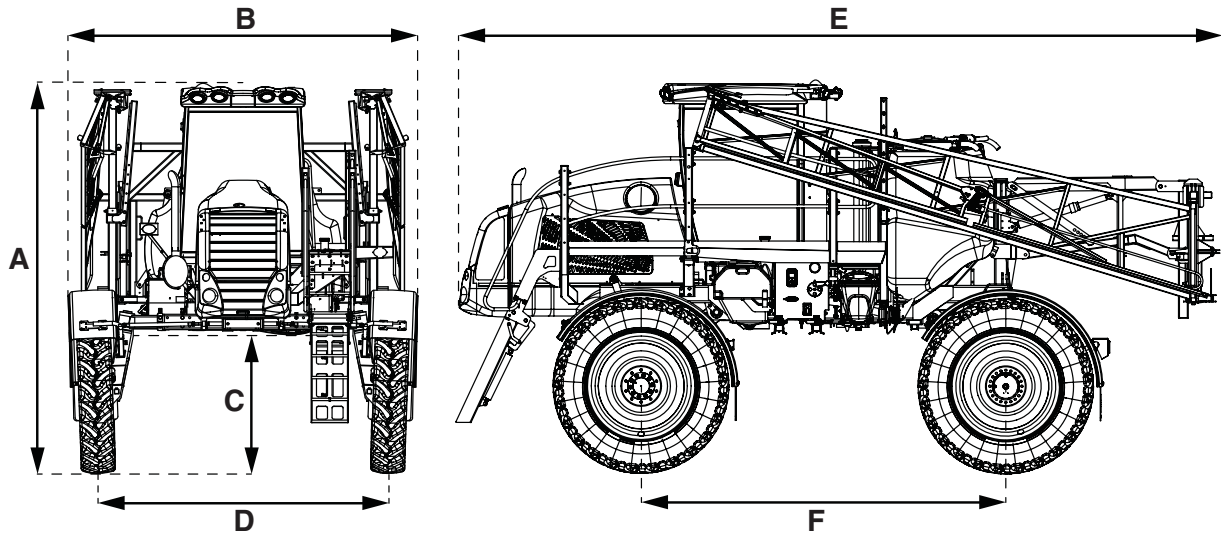

#### Presidio with TR4 Boom

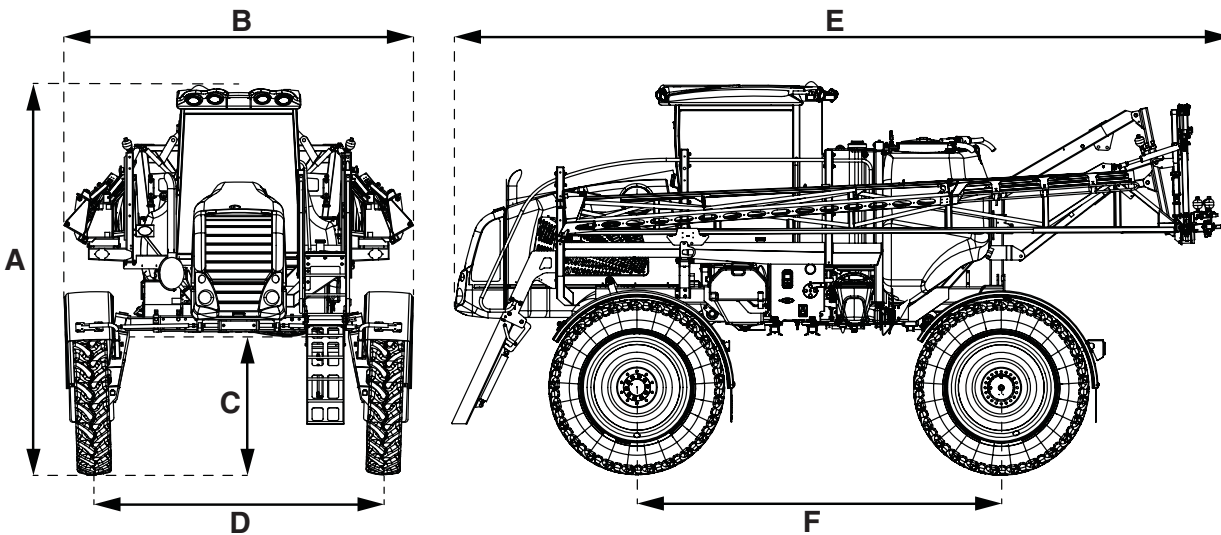

Booms	A	B	C	D (wide axle)	D (narrow axle)	E	F
75', 80' SPC	13 ft. 6 in. (411 cm)	12 ft. 1 in. (368 cm)	54 in. (137 cm)	100 - 120 in. (254 - 305 cm)	80 - 100 in. (203 - 254 cm)	26 ft. 1 in. (796 cm)	150 in. (380 cm)
90' SPC 90'/60' SPC	13 ft. 6 in. (411 cm)	12 ft. 1 in. (368 cm)	54 in. (137 cm)	100 - 120 in. (254 - 305 cm)	80 - 100 in. (203 - 254 cm)	30 ft. 4 in. (924 cm)	150 in. (380 cm)
90' TR4 90'/60' TR4	13 ft. 6 in. (411 cm)	12 ft. 1 in. (368 cm)	54 in. (137 cm)	100 - 120 in. (254 - 305 cm)	80 - 100 in. (203 - 254 cm)	26 ft. 7 in. (810 cm)	150 in. (380 cm)

## 8 - Technical Specifications

---

### Weight

Weight (empty) with 80' SPC boom and 380/90 R46 tires 18,942 lbs (8592 kg).

---

### Tire pressures

Sizes	Load index	Inflation pressure PSI (bar)
<b>380/80 R38</b>	142 A8	35 (2.4)
<b>320/90 R46</b>	148 A8	52 (3.6)
<b>380/90 R46</b>	168 A8	52 (3.6)

### Warranty policy and conditions

HARDI® NORTH AMERICA INC. , 1500 West 76th Street, Davenport, Iowa, USA hereinafter called "HARDI®", offers the following limited warranty in accordance with the provisions below to each original retail purchaser of its own manufacturer, from an authorized HARDI® dealer that such equipment is at the time of delivery to such purchaser, free from defects in material and workmanship and that such equipment will be warranted for a period of one year from the time of delivery to the end user, providing the machine is used and serviced in accordance with the recommendations in the Operator's Manual and is operated under normal farm conditions.

HARDI®'s extended standard 3 year warranty and optional 5 year warranty is underwritten by Ag Guard, 21295 Hollingsworth Road, Tonganoxie, KS 66086, AgGuard.com. All warranty decisions after the first year are at the sole discretion of Ag Guard.

Standard 3 year and optional 5 year self-propelled warranty.

POWER TRAIN covers components that produce, transmit or control engine horsepower for propelling the machine (e.g. engine, engine electronic controls/sensors, turbo, water pump, fuel injection, drive-line couplers/shafts, U-joints, transfer gears, differential, transmission, final drives, axles, hydro, creeper, PTO, etc.).

POWER TRAIN + HYDRAULIC SYSTEMS includes Power train coverage plus hydraulic systems, parts and components associated with steering and implement control (e.g. tanks, pumps, coolers, motors, controls, sensors, valves, cylinders, accumulators, hoses/lines, couplers, swivels, filter bases, etc.).

POWER TRAIN + HYDRAULIC SYSTEMS + PLATFORM includes Power train + Hydraulic Systems coverage plus additional mechanical, electrical and structural components.

Model	Coverage	Terms	Hours	Deductible
Alpha	PT & Hydraulics	3 Years	1,000	\$500.00
Alpha	PT & Hydraulics	5 years	2,000	\$500.00
SARITOR	PT & Hydraulics	3 years	1,000	\$500.00
SARITOR	PT & Hydraulics	5 Years	2,000	\$500.00
PRESIDIO	PT & Hydraulics	3 Years	1,000	\$500.00
PRESIDIO	PT & Hydraulics	5 Years	2,000	\$500.00

1. This limited warranty is subject to the following exceptions:
  - a)Parts of the machine not manufactured by HARDI®, (i.e. engines, tires, tubes, electronic controls and other components or trade accessories, etc.) are not covered by this warranty but are subject to the warranty of the original manufacturer. Any claim falling into this category will be taken up with the manufacturer concerned.
  - b)This warranty will be withdrawn if any equipment has been used for purposes other than for which it was intended or if it has been misused, neglected, or damaged by accident, let out on hire or furnished by a rental agency. Nor can claims be accepted if parts other than those manufactured by HARDI® have been incorporated in any of our equipment. Further, HARDI® shall not be responsible for damage in transit or handling by any common carrier and under no circumstances within or without the warranty period will HARDI® be liable for damages of loss of use, or damages resulting from delay or any consequential damage.
2. We cannot be held responsible for loss of livestock, loss of crops, loss because of delays in harvesting or any other expense or loss incurred for labor, supplies, substitute machinery, rental for any other reason, or for injuries either to the owner or to a third party, nor can we be called upon to be responsible for labor charges, other than originally agreed, incurred in the removal or replacement of components.
3. The customer will be responsible for and bear the costs of:
  - a)Normal maintenance such as greasing, maintenance of oil levels, minor adjustments including the boom.
  - b)Transportation of any HARDI® product to and from where the warranty work is to be performed.
  - c)Dealer travel time to and from the machine or to deliver and return the machine from the service workshop for repair unless otherwise dictated by state law.
  - d)Dealer traveling costs.
4. Parts defined as normal wearing items, (i.e. Tires, Valves and O-rings) are not in any way covered under this warranty.
5. This warranty will not apply to any product which is altered or modified without the express written permission of the HARDI® Service and Engineering Departments and/or repaired by anyone other than an Authorized HARDI® Dealer.



## 9 - Warranty

---

6. Warranty is dependent upon the strict observance by the purchaser of the following provisions:
  - a) That this warranty may not be assigned or transferred to anyone.
  - b) That the Warranty Registration Certificate has been correctly completed by dealer and purchaser with their names and addresses, dated, signed and returned to the appropriate address as given on the Warranty Registration Certificate within 30 days of delivery to the purchaser.
  - c) That all safety instructions in the operator's manual shall be followed and all safety guards regularly inspected and replaced where necessary.
7. This warranty is non-transferable.
8. Subject to the following terms, conditions and contributions, HARDI® extends the warranty on polyethylene tanks (excluding fittings, lids and gaskets) to FIVE YEARS. To qualify for this extended warranty, the tank must be drained and flushed with fresh water after each day's use. HARDI®'s liability is limited to replacement of defective parts FOB our plant in Davenport, IA at no cost to the purchaser for the first twelve months after date of purchase; at 20% of the then current retail price during the second year; at 40% during the third year; at 60% during the fourth year; and at 80% during the fifth year. This extended warranty is subject, in each instance, to the tank being inspected and approved for replacement or repair by HARDI® personnel before HARDI® will accept any liability hereunder.
9. HARDI® reserves the right to incorporate any change in design in its products without obligation to make such changes on units previously manufactured.
10. The judgement of the HARDI® Service Department in all cases of claims under this warranty shall be final and conclusive and the purchaser agrees to accept its decisions on all questions as to defect and the repair or exchange of any part or parts.
11. No employee or representative is authorized to change this warranty in any way or grant any other warranty unless such change is made in writing and signed by the CEO of HARDI® NORTH AMERICA INC. Approval of warranty is the responsibility of the HARDI® Service Department.
12. Any warranty work performed which will exceed \$1000.00 MUST be approved IN ADVANCE by the Service Department. Warranty claims filed without prior approval will be returned.
13. ANY pump replacement MUST be approved by the HARDI® Service Department.
14. Claims under this policy MUST be filed with the HARDI® Service Department within thirty (30) days of when the work is performed or warranty shall be void unless prior arrangements are made.
15. Parts which are requested for return by the HARDI® Service Department must be returned prepaid within thirty (30) days for warranty settlement.
16. Warranty claims must be COMPLETELY filled out including part numbers and quantities or claims will be returned to the submitting dealer.

### DISCLAIMER OF FURTHER WARRANTY

THERE ARE NO WARRANTIES, EXPRESSED OR IMPLIED, EXCEPT AS SET FORTH ABOVE. THERE ARE NO WARRANTIES WHICH EXTEND BEYOND THE DESCRIPTION OF THE PRODUCT CONTAINED HEREIN. IN NO EVENT SHALL THE COMPANY BE LIABLE FOR INDIRECT, SPECIAL OR CONSEQUENTIAL DAMAGES (SUCH AS LOSS OF ANTICIPATED PROFITS) IN CONNECTION WITH THE RETAIL PURCHASER'S USE OF THE PRODUCT.

---

**Index****A**

Adjustment of 3-way-valve, 90  
Agitation, 61  
Agitation before re-starting spraying, 61  
Air conditioning and heating control panel, 57  
Air reservoir, 76

**B**

Boom, 30  
    Operating the boom, 58  
    Operator's Manual, 30  
    Rear transport lock, 58  
Brake accumulator, 90

**C**

Chemical container cleaning lever, 20  
Cleaning  
    Flushing spraying circuit, 67  
    Full internal cleaning, 68  
    Full internal rinsing, 66  
CycloneFilter, 21, 74

**D**

Deutz Display, 24  
Dimensions, 97

**E**

Electrical incidents, 94  
Emergency Exit, 22  
End nozzle, Electrically controlled, 64  
Engine Maintenance  
    Bleed fuel tank, 86  
    Coolant level, 83  
    Engine air filter, 84  
    Engine oil and filter change, 86  
    Engine oil level, 82  
    Fuel system priming, 85  
    Replacing the fuel filters, 85  
    Water separator, 84  
Engine panel, 40  
External electrical controls, 20

**F**

Filling chemicals via the TurboFiller, 63  
Filling filter removal/cleaning, 90  
Filling of water, 59  
Filling the fuel tank, 33  
Filling the hydraulic oil reservoir, 75  
Filling, clean water tank, 60  
Filling, main tank, 59  
Filling, rinse tank, 60  
Frame, 17

**H**

HARDI spray center, 25  
Hydraulic oil filter replacement, 75  
Hydraulic oil level, 75

**I**

Instrument panel area, 23

**L**

Liquid system, 18, 59  
Liquid system diagram, 19

**M**

Multifunction Grip Handle, 25

**O**

Off-season storage, 91  
Operator seat adjustment, 54  
Overhead cab light, 55

**P**

Pneumatic suspension, 76  
Poison information center, 16  
Pump, 18

**R**

Recommended lubricants, 71  
Remote pressure gauge, 31  
Rinsing TurboFiller, 63

**S**

Safety decals, 14  
Safety precautions, 62  
Service and Maintenance intervals, 72  
Side mirror controls, 56  
Sprayer use, 17  
Steering column adjustment, 54  
Steering column switches, 23  
Symbols, 11

**T**

Tanks, 17  
Technical residue, 69  
Tire pressures, 98  
Toe-in, Adjusting, 36  
Towing the vehicle, 79  
Track width, Altering, 35  
Travel lever, 24  
TurboDeflector valve, 20  
TurboFiller, 20

**V**

Valves and symbols, 18

**W**

Warranty policy and conditions, 99  
Weight, 98  
Wheel nuts, 74









**HARDI® North America Inc.**

1500 West 76th St - Davenport, IA 52806

Ph: (563) 386-1730

Customer Service Email: [custserv@hardi-us.com](mailto:custserv@hardi-us.com)

Email: [info@hardi-us.com](mailto:info@hardi-us.com)

Website: [www.hardi-us.com](http://www.hardi-us.com)