

COMMANDER OLH / OLV / OLS

Instruction book

670754-GB-99/06



We congratulate you for choosing a HARDI plant protection product. The reliability and efficiency of this product depend upon your care. The first step is to carefully read and pay attention to this instruction book. It contains essential information for the efficient use and long life of this quality product.

As the instruction book covers all COMMANDER models with OLH, OLV and OLS booms, please pay attention to the paragraphs dealing with precisely your model.

This book is to be read in conjunction with the “Spray Technique” book.

Illustrations, technical information and data in this book are to the best of our belief correct at the time of printing. As it is HARDI INTERNATIONAL A/S policy permanently to improve our products, we reserve the right to make changes in design, features, accessories, specifications and maintenance instructions at any time and without notice.

HARDI INTERNATIONAL A/S is without any obligation in relation to implements purchased before or after such changes.

HARDI INTERNATIONAL A/S cannot undertake any responsibility for possible omissions or inaccuracies in this publication, although everything possible has been done to make it complete and correct.

As this instruction book covers more models and features or equipment, which are available in certain countries only, please pay attention to paragraphs dealing with precisely your model.



Table of contents

| | | | |
|---|----|---|----|
| EC Declaration of Conformity | 4 | Adjustments of EC operating unit | 24 |
| Operator safety | 4 | Operating the control unit while spraying | 24 |
| Description | 5 | Remote pressure gauge (if fitted) | 24 |
| Frame | 5 | Filters | 24 |
| Tank | 5 | Self-cleaning filter | 25 |
| Pump | 5 | Choice of correct restrictor | 25 |
| MANIFOLD SYSTEM | 5 | Filling of chemicals | 25 |
| Operating unit | 5 | Filling through tank lid | 25 |
| Filters | 5 | Filling by HARDI FILLER chemical inductor | 26 |
| Boom | 5 | Use of rinsing tank and rinsing nozzles (if fitted) | 28 |
| Identification plates | 5 | Technical Residue | 28 |
| Sprayer use | 6 | Operation of the tank drain valve | 29 |
| Unloading the sprayer from the truck | 6 | Rinsing tank drain valve | 29 |
| Before putting the sprayer into operation | 6 | Safety precautions | 29 |
| Roadworthiness | 6 | Personal protection | 29 |
| Rear lights | 6 | Disconnecting the sprayer | 30 |
| Connecting the sprayer | 7 | Hose package and transmission shaft support | 30 |
| Drawbars | 7 | Maintenance | 31 |
| Standard and STEER TRACK drawbars | 7 | Cleaning the sprayer | 31 |
| Standard drawbar for DIN 11 025 trailer coupling | 7 | Cleaning and maintenance of filters | 31 |
| Support leg | 7 | Lubrication | 32 |
| SELF TRACK and MULTI TRACK drawbars | 8 | Service and Maintenance | 35 |
| Stop wedges (if fitted) | 8 | 10 hours service | 35 |
| Ladder | 8 | 50 hours service | 35 |
| Transmission shaft | 9 | 250 hours service | 35 |
| Operator safety | 9 | 1000 hours service | 35 |
| Installation of transmission shaft | 9 | Occasional maintenance | 35 |
| Track gauge (without suspension) | 10 | Off-season storage | 49 |
| Track gauge (with suspension) | 11 | Preparation after off-season storage | 49 |
| Brakes | 12 | Fault-finding | 50 |
| Emergency and parking brake (if fitted) | 12 | TRACKER damping system | 50 |
| Hydraulic activated brakes (if fitted) | 12 | Liquid system | 51 |
| Air activated brakes (if fitted) | 12 | Hydraulic system | 52 |
| Single-line brakes (if fitted) | 12 | EC Operating unit | 52 |
| Dual-line brakes (if fitted) | 12 | D.A.H. Hydraulic system | 53 |
| Transport brackets, height settings | 13 | Tyre safety | 54 |
| Hydraulic systems | 14 | Emergency operation of the sprayer | 54 |
| Direct Acting Hydraulic system (OLH/OLV models) | 14 | The boom | 54 |
| Control boxes and power supply (if fitted) | 14 | EC operating unit | 54 |
| Remote control lever (MULTI TRACK only) | 14 | Technical specifications | 55 |
| Hydraulic system (OLS models) | 14 | Measure and weight | 55 |
| Speed regulation of the hydraulic boom movements (OLS models) | 14 | Pump capacity | 56 |
| Counter weight (TRACKER models only) | 15 | Filters and nozzles | 56 |
| Driving Technique | 16 | Filter gauze width | 56 |
| STEER TRACK | 16 | Temperature and pressure ranges | 56 |
| SELF TRACK | 17 | Brakes | 56 |
| MULTI TRACK | 17 | Electrical connections | 56 |
| Operating instructions (The boom) | 18 | EC | 57 |
| OLH boom and OLV boom | 18 | Materials and recycling | 57 |
| OLS boom | 19 | Conversion factors, SI to Imperial units | 57 |
| Operating instructions (MANIFOLD SYSTEM) | 20 | Boom hydraulic OLV (with Multi Track) | 58 |
| Use of MANIFOLD valve system | 20 | Boom hydraulic OLV (with STEER TRACK) | 59 |
| Electric operated MANIFOLD valves (if fitted) | 21 | Boom hydraulic OLV | 60 |
| Filling of water | 21 | Boom hydraulic OLH (with STEER TRACK) | 61 |
| Filling through tank lid | 21 | Boom hydraulic OLH (with MULTI TRACK) | 62 |
| Suction Filling Device (if fitted) | 21 | Boom hydraulic OLS | 63 |
| Fast Filling Device (if fitted) | 22 | Wiring diagram OLS | 63 |
| Filling of rinsing tank (if fitted) | 23 | Subject index | 64 |
| Filling of clean water tank | 23 | | |



EC Declaration of Conformity

Manufacturer,

HARDI INTERNATIONAL A/S
Helgeshøj Allé 38
DK 2630 Taastrup
DENMARK

Importer,

declare that the following product;

A. was manufactured in conformity with the provisions in the COUNCIL DIRECTIVE of 14 June 1989 on mutual approximation of the laws of the Member States on the safety of machines (89/392/EEC as amended by directives 91/368/EEC and 93/368/EEC) with special reference to Annex 1 of the Directive on essential safety and health requirements in relation to the construction and manufacture of machines.

B. was manufactured in conformity with the current standards implementing harmonised standards in accordance with Article 5 (2) and other relevant standards.

Taastrup, June 1999

Erik Holst
Managing Director
HARDI INTERNATIONAL A/S

Adhere extra shipping package labels in the *Product Identification Certificate*.

Operator safety



Watch for this symbol .
It means **WARNING, CAUTION, NOTE**.
Your safety is involved so be alert!

Note the following recommended precautions and safe operating practices.

- 1. Read and understand this instruction book before using the equipment. It is equally important that other operators of this equipment read and understand this book.**
- 2. Local law may demand that the operator be certified to use spray equipment. Adhere to the law.**
- 3. Pressure test with clean water prior to filling with chemicals.**
- 4. Wear protective clothing.**
- 5. Rinse and wash equipment after use and before servicing.**
- 6. Depressurize equipment after use and before servicing.**
- 7. Never service or repair the equipment whilst it is operating.**
- 8. Disconnect electrical power before servicing.**
- 9. Always replace all safety devices or shields immediately after servicing.**
- 10. If an arc welder is used on the equipment or anything connected to the equipment, disconnect power leads before welding. Remove all inflammable or explosive material from the area.**
- 11. Do not eat, drink or smoke whilst spraying or working with contaminated equipment.**
- 12. Wash and change clothes after spraying.**
- 13. Wash tools if they have become contaminated.**
- 14. In case of poisoning, immediately seek medical advice. Remember to identify chemicals used.**
- 15. Keep children away from the equipment.**
- 16. Do not attempt to enter the tank.**
- 17. Do not go under any part of the sprayer unless it is secured. The boom is secure when placed in the transport brackets.**

If any portion of this instruction book remains unclear after reading it, contact your HARDI dealer for further explanation before using the equipment.

Description

Frame

Strong and compact frame with several options of drawbars and wheel sizes. The frame has a strong chemical and weather resistant electrostatic lacquer coat. Screws, nuts, etc. have been DELTA-MAGNI treated to be resistant to corrosion.

Tank

UV-resistant Polyethylene in a suitable design with no sharp corners for easy agitation, emptying and cleaning. Nominal contents 2200, 2800, 3200 or 4200 l.

Pump

Diaphragm pump with 6 diaphragms, model 463 with easily accessible valves and diaphragms.

MANIFOLD SYSTEM

All functions of the spray circuits are operated via the centrally situated MANIFOLD valves with colourcoded plates and pictorial symbols for easy operation.

Operating unit

The operating unit is constructed of modules and consists of main ON/OFF valve, pressure gauge, pressure regulation with built-in HARDI-MATIC and distribution valves with pressure equalization. HARDI-MATIC ensures a constant volume per hectare of the liquid (l/ha) at varying forward speed within the same gear when the number of P.T.O. revolutions are between 300-600 r/min. The operating unit is fully electrically controlled (EC) via remote control box.

Filters

With the self-cleaning filter the impurities that exist in the spray liquid will by-pass the filter and be recirculated back to the tank via the return flow. Also suction filter and nozzle filters are standard. In-line pressure filters can be fitted as option.

Boom

All booms are suspended in a strong, stable parallelogram boom lift.

The OLS boom is pendulum suspended. The raising/lowering and folding/unfolding functions are operated via the tractor hydraulics.

The OLH boom and the OLV boom are pendulum suspended and are fully hydraulically operated. All functions are controlled via the Direct Acting Hydraulic system (D.A.H.). The OLH boom is also equipped with individual boom tilt control.

The booms are available in 18, 20, 21, 24, 27 and 28 m working width, depending on sprayer model.

Identification plates

An identification plate fitted on the frame indicates producer name, model, own weight, max. weight, max. pressure of the hydraulic system, and max. pressure of the spray liquid system. Frame, boom centre frame, and inner/outer sections also have identification plates indicating boom type and part number of spare parts. If ordering spare parts, inform your dealer of these, so the right model and version are described.

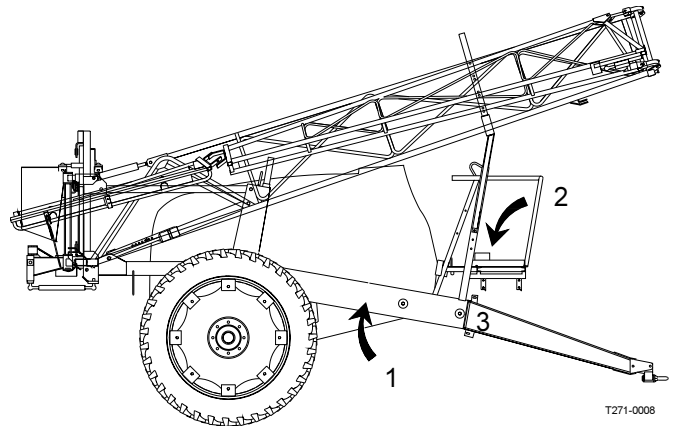

Write the information of your sprayer here:

1.

| | | | |
|---|--|--|--|
| HARDI INTERNATIONAL A/S HELGESHOJ ALLE 38, DK-2630 TÅSTRUP, DENMARK Fabrikant, Marke, Handels-Merkmal: HARDI Type, Typ, Typus: CM 2 Serie nr., Serial No., Fabrikant-Nr., No. Série, Num. Série: _____ Fabrikationsår, Production Year, Baujahr, An. Fabrication, Año Fabricación: _____ Kapacitet, Capacity, Kapazität, Capacité: L _____ Identifikation: Skæbnest., Division, Last, Skæbnest., Change Filtration, Precision del. Tilførsel: _____ kg Egenvegt, Unladen Vægt, Løstevægt, P.V., Peso Propio: _____ kg | | | |
| Model, Typ, Typus Dimensioner Dimensioner i mm Dimensioner i inch | Løstevægt Zul. Anlast Zul. Stützlast Zul. Stützlast | Max. arbejds-tryk, Max.工作压力 Zul. Arbejds-tryk Zul. Arbeitsdruck Zul. Arbeitsdruck | Max. sprøjte-tryk Zul. Sprøjte-tryk Zul. Sprühdruk Zul. Sprühdruk |
| 230/95 R44 | 124 AB | 4650 kg | 6010 kg |
| 230/95 R48 | 135 AB | 4790 kg | 6140 kg |
| 270/95 R44 | 140 AB | 5500 kg | 6500 kg |
| 270/95 R48 | 142 AB | 5830 kg | 6500 kg |
| 12.0H46 | 145 AB | 6300 kg | 6500 kg |

2.

| | |
|---|-------|
| HARDI INTERNATIONAL A/S HELGESHOJ ALLE 38, DK-2630, DENMARK | |
| Model: | _____ |
| Serial no.: | _____ |
| Technical specifications: see the Users Instruction Manual! | |

3.

| | | | |
|--|----------------------|------|--------|
| HARDI INTERNATIONAL A/S HELGESHOJ ALLE 38, 2630 TÅSTRUP, DENMARK | | Type | 637671 |
| | Zul. Gesamtgewicht | 6500 | kg |
| | Zul. Stützlast | 1350 | kg |
| D-Wert: 24,9 kN | Max. Geschwindigkeit | 25 | km/h |

(Certain countries only)

T279-0005
T279-0002
T279-0006

Sprayer use

The HARDI COMMANDER sprayer is for the application of crop protection chemicals and liquid fertilisers.

The equipment must only be used for this purpose. It is not allowable to use the sprayer for other purposes.

If no local law demands that the operator must be certified to use spray equipment, it is strongly recommended to be trained in correct plant protection and in safe handling of plant protection chemicals to avoid unnecessary risk for persons and the environment when doing your spray job.

Unloading the sprayer from the truck

For the unloading of the sprayer, you need a crane or a fork lift.

When loading with a crane please observe the lifting points as shown on the sketch, and make sure that the straps or belts used for lifting are strong enough.

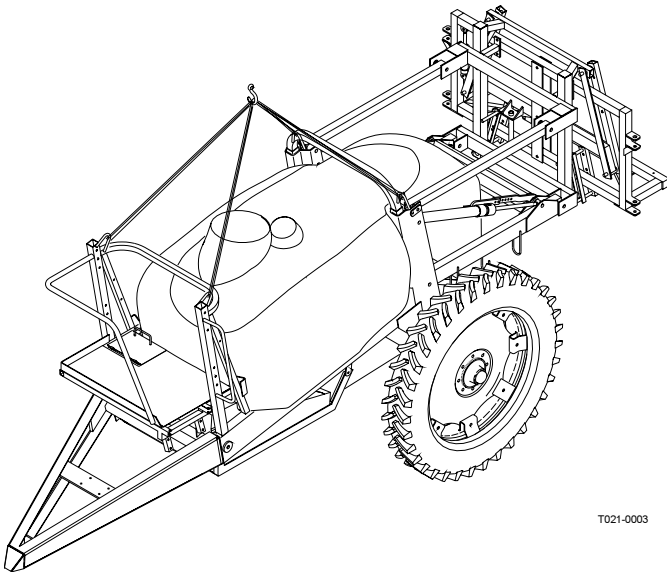

Before putting the sprayer into operation

Although the sprayer has been applied with a strong and protective surface treatment on steel parts, bolts etc. in the factories, it is recommended to apply a film of anticorrosion oil (e.g. CASTROL RUSTILLO or SHELL ENSIS FLUID) on all metal parts in order to avoid chemicals and fertilisers discoloring the enamel.

If this is done before the sprayer is put into operation for the first time, it will always be easy to clean the sprayer and keep the enamel shiny for many years.

This treatment should be carried out every time the protection film is washed off.

Roadworthiness

When driving on public roads and other areas where the highway code applies, or areas where there are special rules and regulations for marking and lights on implements, you should observe these and equip implements accordingly.

NOTE! Max. driving speed is 25 km/h (15.5 Mph).

Rear lights

Before transport on public roads the front warning boards with position lamps must be folded out (fitted in certain countries only).

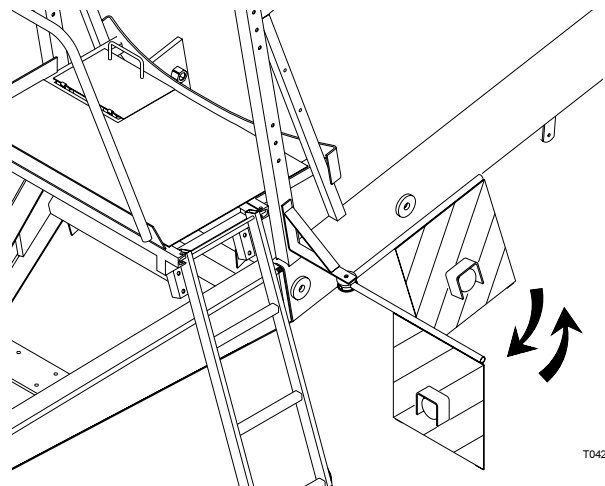

Connect plug for rear lights to the tractor's 7-pin socket and check the functions of rear lights, stop lights and direction indicators on both sides of the sprayer before driving.

The wiring is in accordance with ISO 1724. (See section on Technical Specifications).

Connecting the sprayer Drawbars

Standard and STEER TRACK drawbars

There are different drawbars available. Standard drawbar is with a Ø36 mm towing ring.

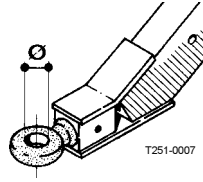

| | |
|-----------------------------------|-------------------|
| Standard drawbar | Ø36 mm |
| Hitch (option) | Ø51 mm (ISO 5692) |
| Jaw (option) | Ø36 mm |
| Drawbar for high hitch DIN 11 025 | Ø40 mm |

The standard and hitch drawbar can be set at two different height positions altering the height approx. 200 mm (8 in) on 2200/2800 and 300 mm (12 in) for 3200/4200. Choose the setting where the platform appears level.

Swivel type Ø36 mm

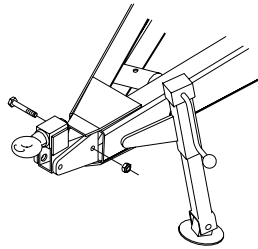
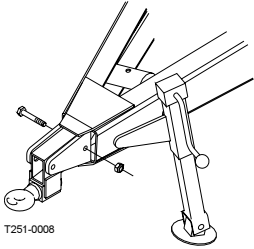

Swivel type Ø36 mm

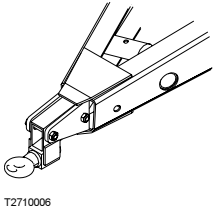

Swivel type Ø33 mm

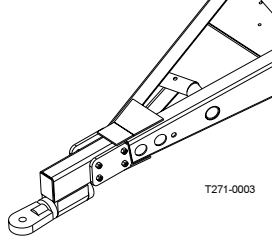

Swivel type Ø50 mm

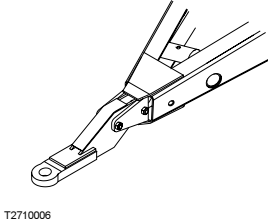

Swivel type Ø50 mm

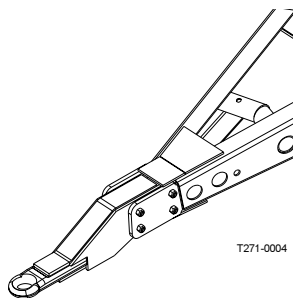

Fork type Ø30 mm

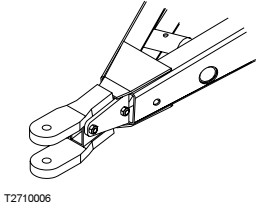

Standard drawbar for DIN 11 025 trailer coupling

2200/2800 I:

The standard trailer drawbar can be turned 180° and is used for the high positioned trailer coupling (DIN 11 025) at the tractor (used in certain countries only).

A kit consisting of a support jack, diaphragm pump, adapter frame and a towing eye is required for this set-up.

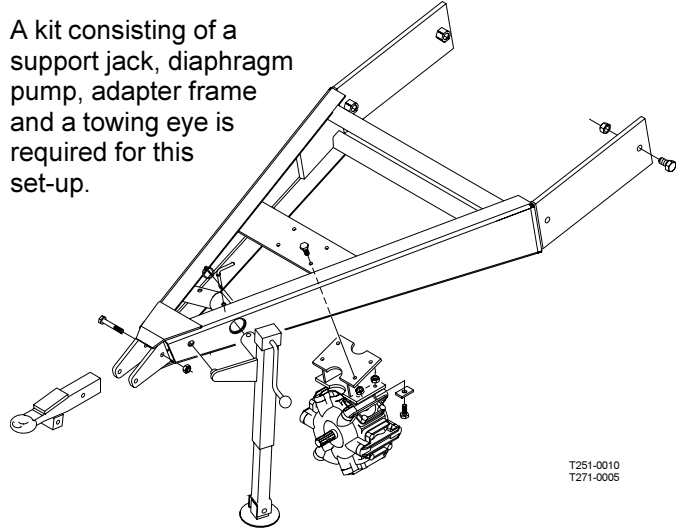

3200/4200 I:

The high hitch drawbar is a factory fitted option and it is different to the standard drawbar.

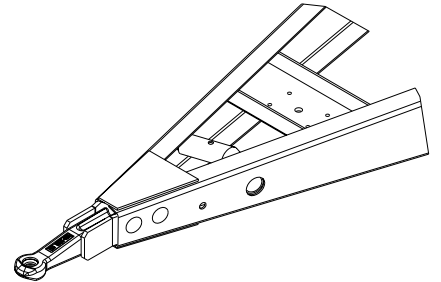

WARNING! The drawbar bolts must be retightened to the specified torque **every 10 hours** of work until the torque is stabilised and then at intervals according to service scheme.



WARNING! Always use a 40 mm (1.57 in) drawbar pin for attaching the drawbar and secure with linch pin or similar.

Support leg

To remove the support leg: lift the leg, remove the securing pin and pull out the support leg.

The support leg is stored in the bracket when the sprayer is attached to the tractor.

SELF TRACK and MULTI TRACK drawbars (2200/2800/3200)

The SELF TRACK and MULTI TRACK are connected as follows:

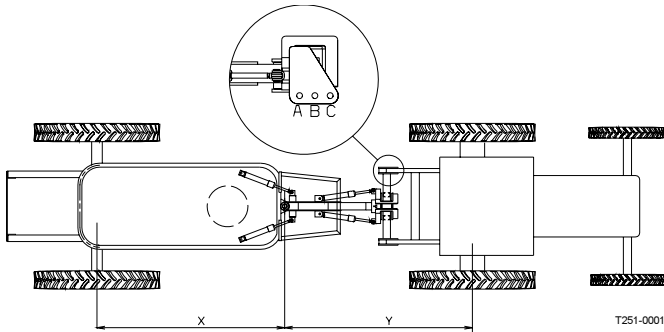

T251-0001

1. Attach the tractor lower links in either hole A, B or C. To obtain best tracking, chose the holes where the distance X are equal to distance Y. Secure with linch pins.
2. Attach safety chains to top link clevis. The chain will prevent the transmission shaft from being damaged if the lift arms are lowered too far. Adjust the chain length so the chains are tight as the tractor P.T.O. and pump shaft are in a horizontal line.

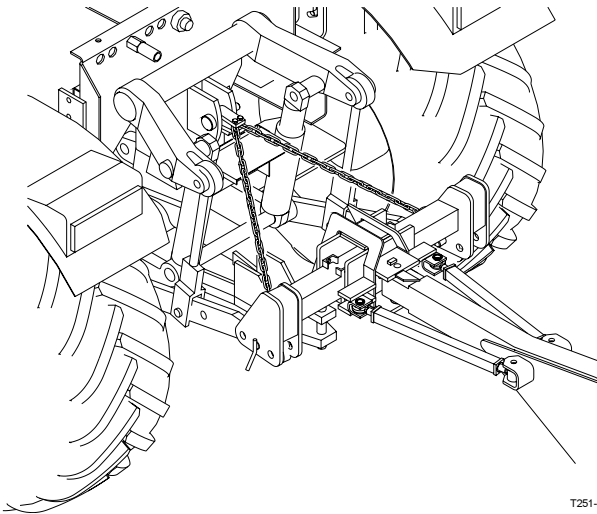

T251-0002

NOTE! If possible, lock the tractor hydraulic lever when the lift arms are in the correct position to avoid the sprayer weight resting on the stabiliser chains.

3. Tighten the lift arms stabiliser chains.



WARNING! Do not stand in the area around the drawbar during manoeuvring.

Stop wedges (if fitted)

Before driving, remove the stop wedges and place them in the storage brackets.

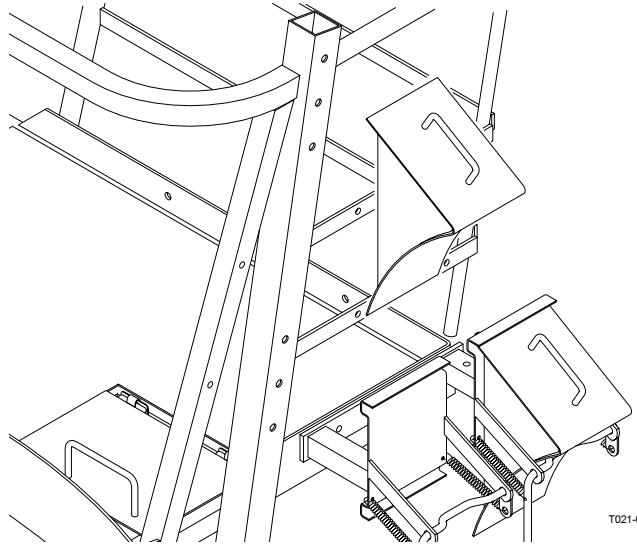

T021-0004

Ladder

To access the front platform the ladder is pulled out and folded down.

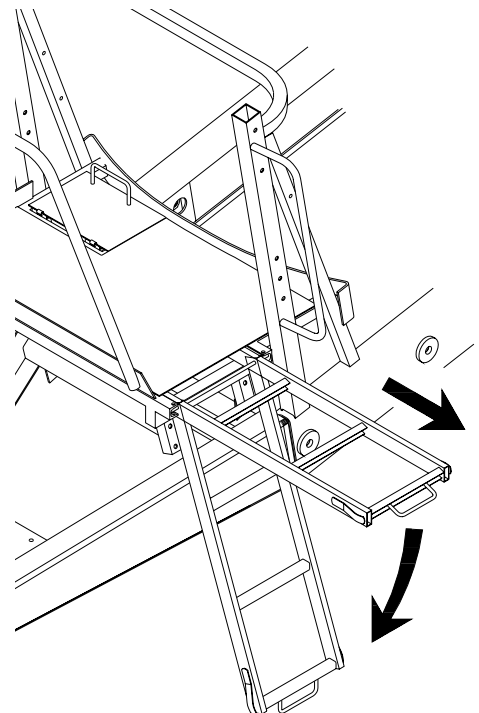

T021-0005

Always lift up and push the ladder inward under the platform before driving. The ladder will lock automatically when it is pushed fully in.

Transmission shaft

Operator safety

To avoid accidents and personal injuries, note the following recommended precautions and safe operation practices.

Always STOP ENGINE before attaching the transmission shaft to tractor P.T.O. - most tractor P.T.O. shafts can be rotated by hand to facilitate spline alignment, when engine is stopped.

When attaching the shaft, make sure that the snap lock is FULLY ENGAGED - push and pull shaft until it locks.



WARNING! ROTATING TRANSMISSION SHAFTS WITHOUT PROTECTION GUARDS ARE FATAL.

Always keep protection guards and chains intact and make sure that it covers all rotating parts, including CV-joints at each end of the shaft. Do not use without protection guard.

Do not touch or stand on the transmission shaft when it is rotating - safety distance: 1.5 meter.

Prevent protection guards from rotating by attaching the chains allowing sufficient slack for turns.

Make sure that protection guards around tractor P.T.O. and implement shaft are intact.

Always STOP ENGINE and remove the ignition key before carrying out maintenance or repairs to the transmission shaft or implement.

Installation of transmission shaft

First installation of the transmission shaft is done in the following way:

1. Attach sprayer to tractor and set sprayer height in the position with shortest distance between the tractor and sprayer pump P.T.O. shafts.
2. Stop engine and remove ignition key.
3. If transmission shaft must be shortened, the shaft is pulled apart. Fit the two shaft parts at tractor and sprayer pump and measure how much it is necessary to shorten the shaft. Mark the protection guards.

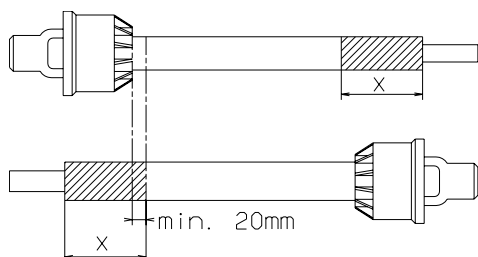

T259-0004

NOTE! The shaft must always have an overlap of minimum 155 mm (6.1 in).

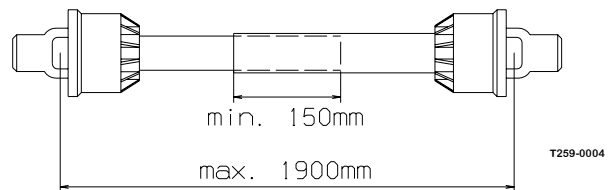

T259-0004

4. The two parts are shortened equally. Use a saw, and file the profiles afterwards to remove burrs.

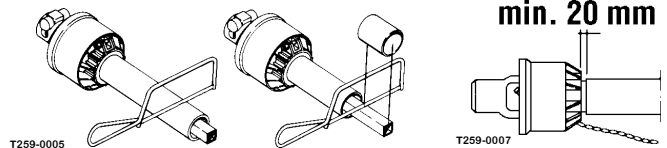

T259-0005

T259-0007

5. Grease the profiles and assemble male and female parts again.
6. Fit the shaft to tractor P.T.O. and sprayer pump shaft.

NOTE! Female part marked with a tractor towards tractor!

7. Fit the chains to prevent the protection guards from rotating with the shaft.

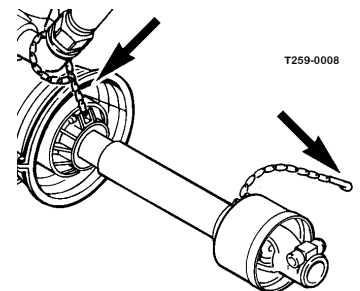

T259-0008

8. To ensure long life of the transmission shaft, try to avoid working angles greater than 15°.

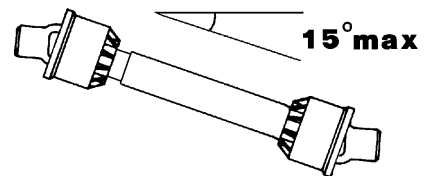

T259-0009

9. *Only 1302 pump:* Transmission shafts with cone must be fitted by tightening the allen screw to a torque of 40 Nm. Check again after 2 minutes of use.

Track gauge (without suspension)

The track gauge of the COMMANDER can be altered stepless as follows:

| | | |
|--|--|--------------------------|
| Model | 2200/2800 mm (in) | 3200/4200 mm (in) |
| Standard adjustment | 1664-2214 (65.6-87.2) | 1800-2250 (71.9-88.6) |
| Adjustment range, change of rim plate and and rim position | 1500-1664 (59.1-65.6) 2214-2250 (87.2-88.7) | ---- |
| Adjustment range, shortening ends | ---- | 1500-1950 (59.1-76.8) |

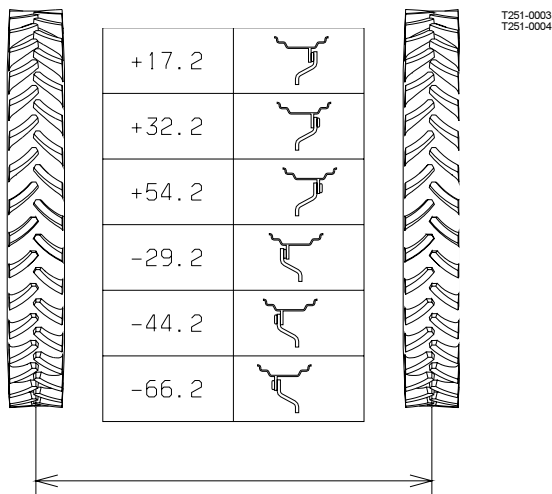

WARNING! When altering track gauge by turning rims and rim plates the max. permitted off-set between centre wheel and hub flange must be observed:

Max offsets, hub flange and centre rim:

| | |
|-----------|-----------------|
| CM: | Max rim offset: |
| 2200/2800 | 66 mm (2.6 in) |
| 3200/4200 | 30 mm (1.18 in) |

Use only the combinations shown. It is not permitted to fit dual wheels!

IMPORTANT! On TRACKER models a minimum track gauge of 1800 mm (71 in) is strongly recommended to ensure stability and avoid tipping over.

NOTE! The wider the track gauge, the better the stability of the sprayer and boom.

Track gauge is altered in the following way:

1. Measure the current track gauge (centre RH tyre to centre LH tyre). Each side must be extended or retracted half the desired alteration.
2. Attach the sprayer to tractor and engage tractor parking brake.

3. Place stop wedges in front of and behind RH wheel. Jack up LH wheel, support and secure sprayer body.
4. Loosen clamp bolts for LH wheel axle.

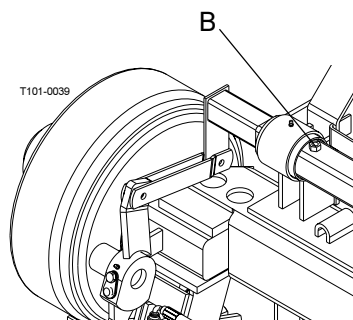
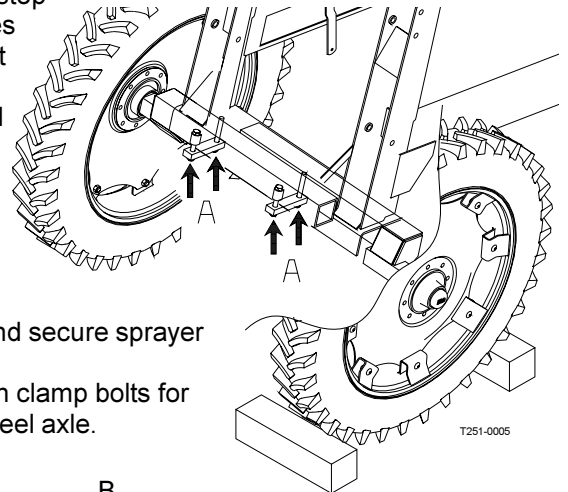

5. 3200/4200 only: Loosen the nut B on the brake operating arm. Extend/retract this arm according to the adjustment of the axle.

6. Extend or retract the axle. A sack barrow and a rod will facilitate the operation.
7. If the rim position must be changed, do this first and fine adjust by extending or retracting the axles. Remember to tighten the wheel nuts to the specified torque: Rim plate to rim: 280 + 30 Nm (207 + 22 lbft) Rim plate to hub: 490 Nm (288 lbft)
8. Tighten the clamp bolts to a torque of 280 Nm (207 lb.ft) for 2200/2800 and 390 Nm (289 lbft) for 3200/4200.
9. 3200/4200 only: Tighten nut B again.

IMPORTANT! Place the jack under the axle and lift the wheel to remove load from the clamps before tightening the clamp bolts to the specified torque.

10. Repeat the procedure on RH wheel.
11. Check the distance from centre tyre to centre of tank frame is equal at RH and LH.
12. Retighten clamp bolts and wheel bolts to specified torque after 8 hours of work.

Track gauge (with suspension)

Overview of tyre dimensions and track widths

2200/2800

| Wheel dimension | Tyre width | Min. track width | Max. track width |
|-----------------|------------|------------------|------------------|
| | mm | mm | mm |
| 9.5 x 44" | 235 | 1701 | 2250 |
| 9.5 x 48" | 235 | 1701 | 2250 |
| 11.2 x 44" | 276 | 1742 | 2250 |
| 11.2 x 48" | 276 | 1742 | 2250 |
| 12.4 x 46" | 310 | 1776 | 2250 |
| 16.9 x 38" | 429 | 1895 | 2250 |
| 18.4 x 38" | 467 | 1933 | 2250 |
| 20.8 x 38" | 528 | 1994 | 2250 |

3200/4200

| Wheel dimension | Tyre width | Min. track width | Max. track width |
|-----------------|------------|------------------|------------------|
| | mm | mm | mm |
| 11.2 x 44" | 276 | 1766 | 2250 |
| 11.2 x 48" | 276 | 1766 | 2250 |
| 12.4 x 46" | 310 | 1800 | 2250 |
| 16.9 x 38" | 429 | 1919 | 2250 |
| 18.4 x 38" | 467 | 1957 | 2250 |
| 20.8 x 38" | 528 | 2018 | 2250 |

Min. track width is the practical minimum figure, independently of rim/rim plate setup.

The track gauge of the COMMANDER with suspension can be altered stepless as follows:

1. Measure the current track gauge (centre RH tyre to centre LH tyre). Each side must be extended or retracted half the desired alteration.

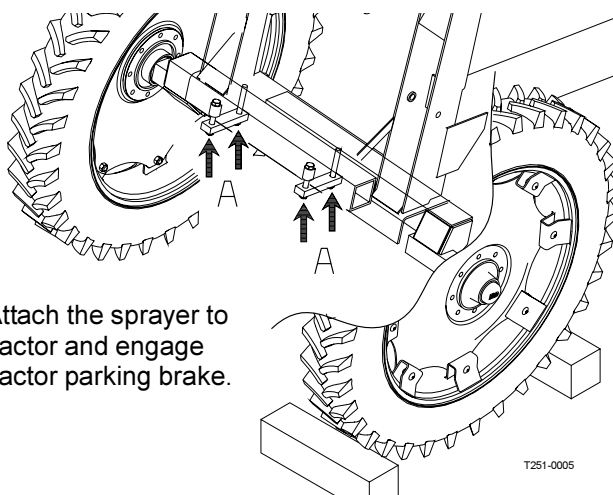

2. Attach the sprayer to tractor and engage tractor parking brake.

3. Place stop wedges in front of and behind RH wheel. Jack up LH wheel, support and secure sprayer body.

4. Loosen the 3 clamp bolts (A) for LH wheel axle.

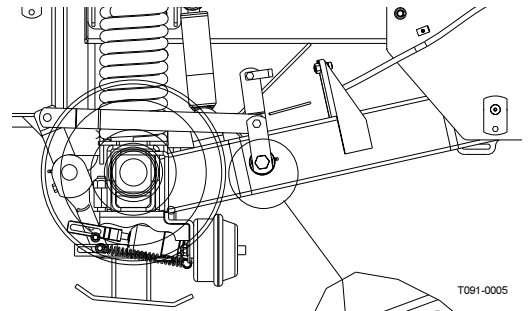

5. Loosen the screw B on the brake operating arm. Extend/retract this arm according to the adjustment of the axle.

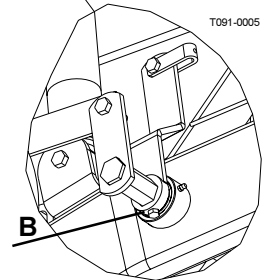

6. Then extend or retract the axle. A sack barrow and a rod will facilitate the operation.

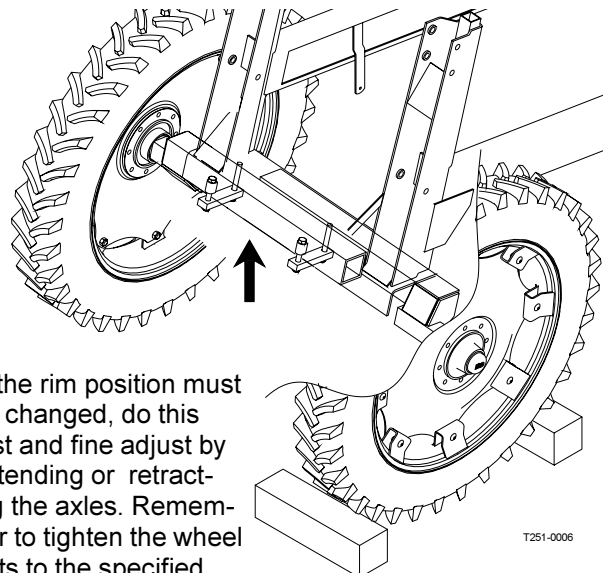

7. If the rim position must be changed, do this first and fine adjust by extending or retracting the axles. Remember to tighten the wheel nuts to the specified torque:

Rim plate to rim: 280 + 30 Nm
(207 + 22 lbft) Rim plate to hub: 490 Nm (288 lbft)

8. Tighten the 3 clamp bolts (A) to a torque of 280 Nm (207 lbft) for the COMMANDER 2200/2800 and 390 Nm (289 lbft) for the COMMANDER 3200/4200.

9. Tighten nut B again.

IMPORTANT! Place the jack under the axle and lift the wheel to remove load from the clamps before tightening the clamp bolts to the specified torque.

10. Repeat the procedure on RH wheel.
11. Check the distance from centre tyre to centre of tank frame is equal at RH and LH.
12. Re-tighten clamp bolts and wheel bolts to specified torque after 10 hours of work.

Brakes

Emergency and parking brake (if fitted)

The parking brake lever can be set for two different function modes:

1. Normal parking brake function (pull to engage, pull again to disengage)
2. Emergency brake (engaged by pulling, no disengagement when pulling again)

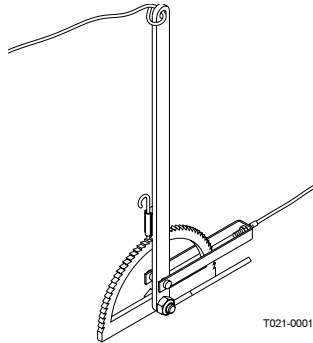

T021-0001

To change between the two modes, turn the pawl control clip.

To disengage the parking brake:

1. Set pawl clip in pos. 1.
2. Pull the lever a little forward to release the ratchet tooth and then push the lever fully backwards.

To engage the parking brake:

1. Pull the lever firmly forwards until parking brake is fully engaged.

Emergency brake

1. Set pawl clip in pos. 2.
2. Attach the rope from the hole in top of the handbrake lever to e.g. the tractor top link attaching point. If the sprayer is accidentally unhooked during transport the rope will apply the parking brake before the rope breaks.

IMPORTANT! To ensure safe engagement and to avoid damages to the parking brake use rope with an ultimate stress between 690 N (155 lb.) and 785 N (176 lb.).

Hydraulic activated brakes (if fitted)

This requires a special trailer brake valve attached to the tractor hydraulic and brake system. Connect the snap coupler to the tractor brake outlet. When the tractor brakes are applied, the trailer brakes will work proportionally to the tractor brakes, and ensure safe and effective braking.

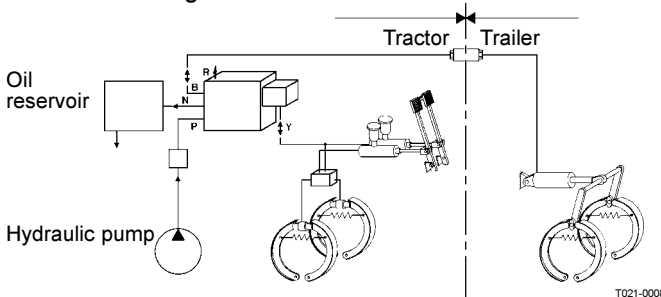

T021-0008



WARNING! Do not connect the brakes directly to the tractor hydraulics without the brake valve. The trailer brake power cannot be

controlled, and braking will therefore be hazardous.

IMPORTANT! Max. oil pressure is 150 bar (2175 p.s.i.) in the brake line.

Relieve parking brake before driving.

Air activated brakes (if fitted)

This system requires a tractor with compressor and air brake system with outlet(s) for trailer brakes.

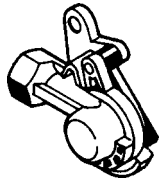

T021-0009

IMPORTANT! The load apportioning valve must be set at the position corresponding to the load on the trailer, for obtaining optimal air pressure to the trailer brakes.

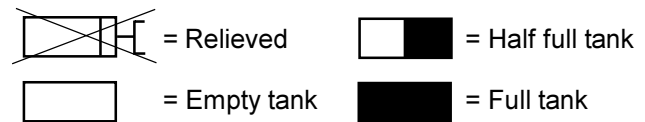

WARNING! Driving with wrong load apportioning valve setting, will make the brakes under- or over-apply, which can cause hazardous situations.

NOTE! If the air hose(s) are disconnected with air in the brake air tank, control pressure will be dumped and the brakes will engage fully. If the sprayer must be moved with air in the tank and without the air hose(s) connected to the tractor, the load apportioning valve must be set at "relieved" to disengage the brakes. Remember to reset the handle to brake position again afterwards. When parking the sprayer, always engage the parking brake, as the air brakes will only be engaged as long as there is air in the tank! Cover the couplings with the dust flaps when hoses are disconnected.

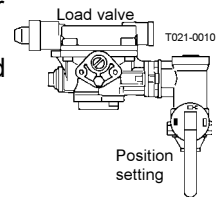

T021-0010

Single-line brakes (if fitted)

Flip the snap coupler protection flap away and connect the brake system snap coupler to the tractor outlet (black) and let the compressor fill the sprayer's air reservoir. Check brake circuit for leaks.

Dual-line brakes (if fitted)

Flip the snap coupler protection flaps away and connect the two snap couplers for supply and control to the tractor outlets, and check brake circuits for leaks.

The couplers are colour coded and secured against incorrect attachment:

Red = Supply line (RH)
Yellow = Control line (LH)

Relieve parking brake before driving

Transport brackets, height settings (> 20m boom)

The transport brackets can be set in different positions to have different transport heights to obtain suitable clearance above various tractor cabins.

The transport brackets are to be set at a combination which gives sufficient clearance to the tractor cab and a transport height as low as possible.

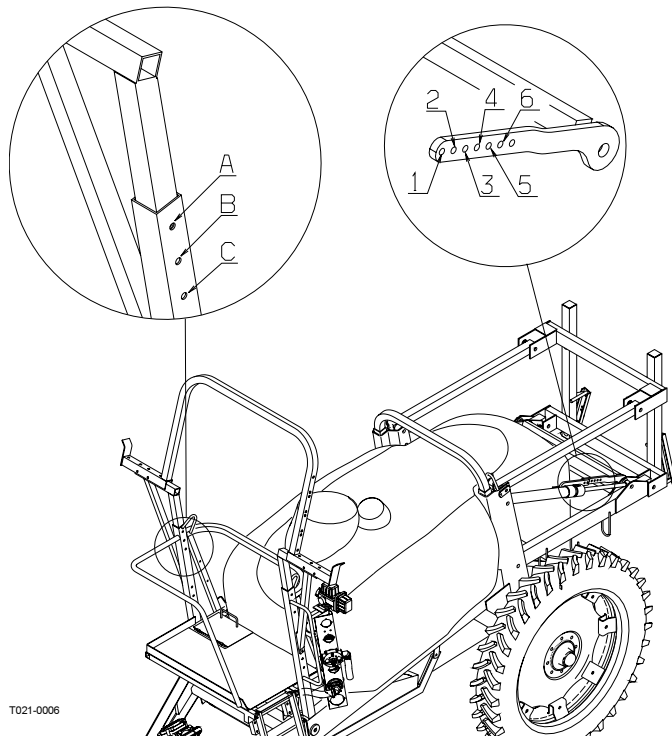

NOTE! The rear settings must correspond to the front settings so the boom is resting on the front as well as rear brackets.



WARNING! The max. transport height must never exceed 4.0 m (13.1 ft) Always measure the actual total height, and choose settings not exceeding 4.0 metre.

Hydraulic systems

Direct Acting Hydraulic system (OLH/OLV models)

The D.A.H. system requires a double acting hydraulic outlet. The hydraulic hoses are marked with arrows to indicate direction of oil flow.

The D.A.H. system requires an oil flow between 10 and 90 l/min (19.8 Imp. gal/min.) and a min. pressure of 130 bar (1886 p.s.i.) The system has a built-in flow regulator that maintains constant speed on hydraulic movements.

Before operating the hydraulics, the clip at the distribution valve (situated under the platform behind the pump) should be set for OPEN CENTRE or CLOSED CENTRE tractor hydraulics, depending on tractor model.

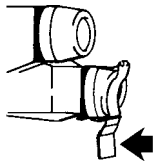

Unlocked =
Open centre hydraulics (Constant Flow)

T020-0024

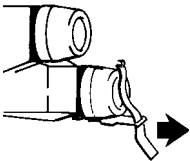

Locked =
Closed centre (Constant Pressure and Load-Sensing hydraulics)

If you are in doubt about which type of hydraulic system your tractor is equipped with, ask your tractor dealer.

Control boxes and power supply (if fitted)

12V power sockets are required for the control boxes. Note polarity!

| Control box for | Polarity (wire colour) | | Required Fuse, Amp |
|-------------------|------------------------|--------------|--------------------|
| | Positive (+) | Negative (-) | |
| EC operating unit | Brown | Blue | 8 |
| D.A.H Hydraulic | White | Black | 16 |
| MANIFOLD valve | Brown | Blue | 8 |

The control boxes are to be fitted in the tractor cabin at a convenient place.

The wires must have a cross-sectional area of at least 4.0 mm² to ensure sufficient power supply. The boxes must be fused according to the table.

Remote control lever (MULTI TRACK only)

Fit the bracket for the tracking/non-tracking remote control lever in the tractor cab.

Hydraulic system (OLS models)

One single acting and one double acting outlet are required. First adjust folding speed as described below.

Speed regulation of the hydraulic boom movements (OLS models)

Adjustable restrictors for regulation of boom unfolding speed are located on the lower hydraulic distribution block (fitted at the boom centre frame). It is important to adjust the valves so that the boom operates smoothly.

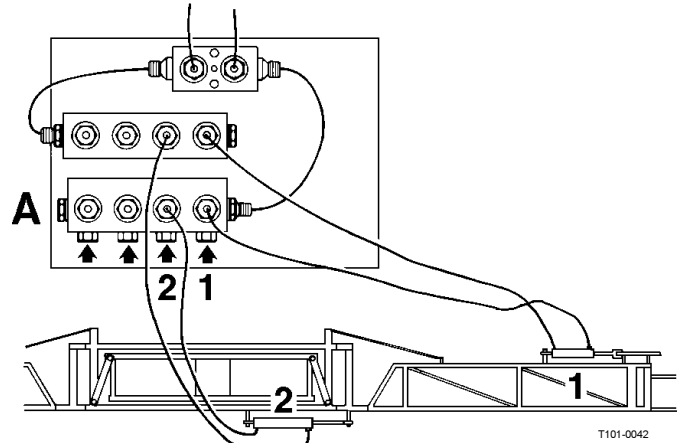

Proceed as follows:

1. Adjust the screws of the throttle valve **A**. They are screwed the whole way in clockwise, and then 1 1/2 turn back. The system is now basically adjusted.
2. Unfold and fold the boom several times in order to heat the oil and remove air from the system.
3. Set the adjustment screws on the throttle valve until the individual rams run with the speed wanted (clockwise = less speed).



WARNING! Test of the hydraulic system should be done very cautiously. There may be air in the system, which may cause violent movements of the boom. Therefore, take care that no persons or objects are hurt or damaged in the process of testing.



WARNING! Hydraulic leaks: Never use your fingers to locate a leakage in any part of the hydraulic system. Due to high pressure, hydraulic oil may penetrate the skin.

Counter weight (TRACKER models only)

To improve stability on TRACKER models, extra weight can be added by means of liquid-filled tyres.

The standard tyre valve is an universal air-water valve.

The tyres can be filled with liquid to max. 75% of their total volume. The table below indicates the 75% volume.

| Tyre size | Max. litres of liquid per tyre |
|------------|--------------------------------|
| 9.5 x 44" | 101 |
| 9.5 x 48" | 108 |
| 11.2 x 44" | 133 |
| 11.2 x 48" | 144 |
| 12.4 x 46" | 178 |
| 16.9 x 38" | 285 |
| 18.4 x 38" | 390 |
| 20.8 x 38" | 466 |

chart 001

Use a mixture of water and CaCl_2 to avoid frost damage as described in table below:

| | |
|---------------------------------|----------------|
| CaCl_2 per litre water | Protection to |
| 200 g (7.1 oz) | -15°C (30.6°F) |
| 300 g (10.6 oz) | -25°C (12.6°F) |
| 435 g (15.4 oz) | -35°C (-5.4°F) |



WARNING! It is very important that the CaCl_2 is added to the water and agitated until it is fully dissolved. Never pour water on to CaCl_2 ! If you get CaCl_2 in the eyes, flush instantly with cold water for at least 5 minutes and seek medical advice afterwards.

IMPORTANT! The tyres must be liquid filled to max. 75% of total tyre volume. Fill only the qty. of liquid necessary to obtain sufficient stability of the sprayer. Do not fill liquid and CaCl_2 mixture in tyres without tubes!

To fill the tyres:

- Jack up the wheel and rotate wheel till the valve is positioned at "12 o'clock".
- Remove the valve body and fill liquid until it reaches the valve.
- When surplus liquid is drained through the valve stem fit the valve body again.
- Adjust tyre pressure and lower the wheel. See section "Tyre pressure".

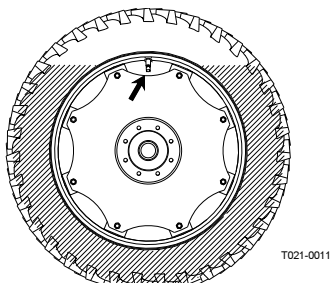

T021-0011

NOTE! When filling the tyres the valve should be positioned at 12 o'clock and when adjusting the tyre pressure, the valve should be positioned at 6 o'clock.

To empty tyres:

- Rotate wheel till the valve is positioned at "6 o'clock."
- Remove the valve body and let out the liquid. Retain liquid in an appropriate container.
- To empty the tyre completely the tyre is inflated and a thin drain tube is lead to the bottom of the tyre. The air pressure will now empty the remaining liquid.
- Remove the drain tube, fit the valve and inflate the tyre to specified pressure. See section "Tyre pressure".

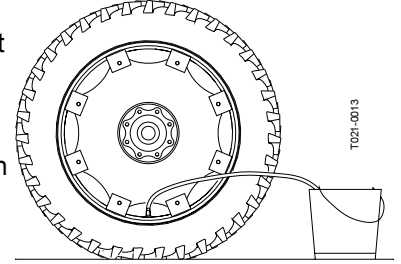

T021-0013

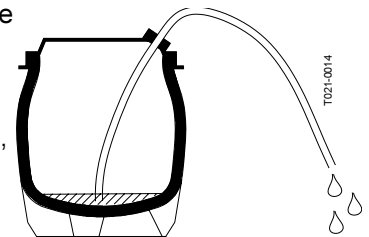

T021-0014

NOTE! Disposal of CaCl_2 has to take place according to local legislation.

Driving Technique

STEER TRACK, SELF TRACK and MULTI TRACK

A trailer sprayer with articulating drawbar (TRACKER) behaves differently than a normal trailer.

In tracking position the vehicle centre of gravity is displaced further more compared to the vehicle centre line of a normal trailer.

Compared to a conventional trailer a TRACKER has decreased stability when turning, especially when turning on hill-sides.

To avoid over-balancing, pay attention to these guidelines:

1. Avoid sudden, tight turns
2. Slow down before entering a curve or turning, and drive with a constant, low speed during the turn.
3. Never slow down too fast, brake heavily or stop suddenly in a curve, or when turning on a hill-side, when the sprayer is articulated.
4. Be careful when turning on uneven ground
5. Set the track gauge as wide as possible
6. The proper function of the hydraulic damping is essential to obtain good stability
7. Keep stabiliser chains on the tractor's liftarms tight
8. For safety reasons, the following limitations are set for TRACKERS (with unfolded booms):

| | |
|-------------------------------------|------------------|
| Speed by turning, max. | 4 km/h (2.5 mph) |
| Ground inclination by turning, max. | 8° |
| Track gauge, min. | 1800 mm (71 in) |

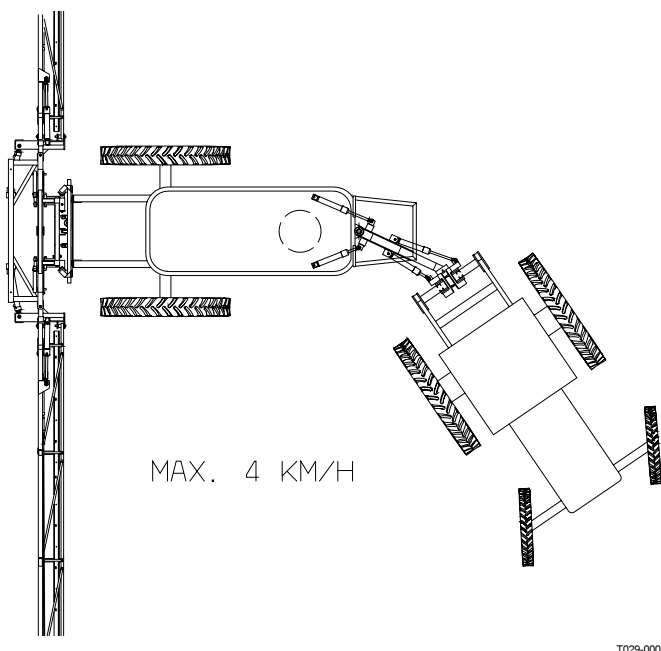

NOTE! HARDI cannot undertake any responsibility for any damages caused by the sprayer tipping over.

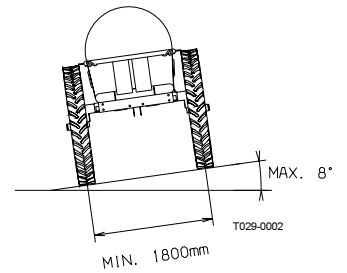

STEER TRACK

The articulating drawbar on STEER TRACK is to be operated manually via the D.A.H.

The switch on the D.A.H. control box is pushed side-wards to articulate the drawbar.

This is used when turning or as track correction when driving on slopes.

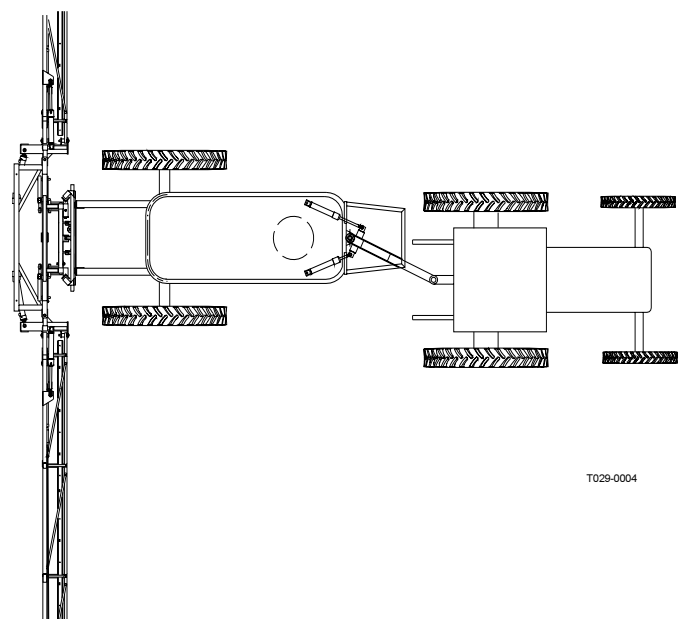
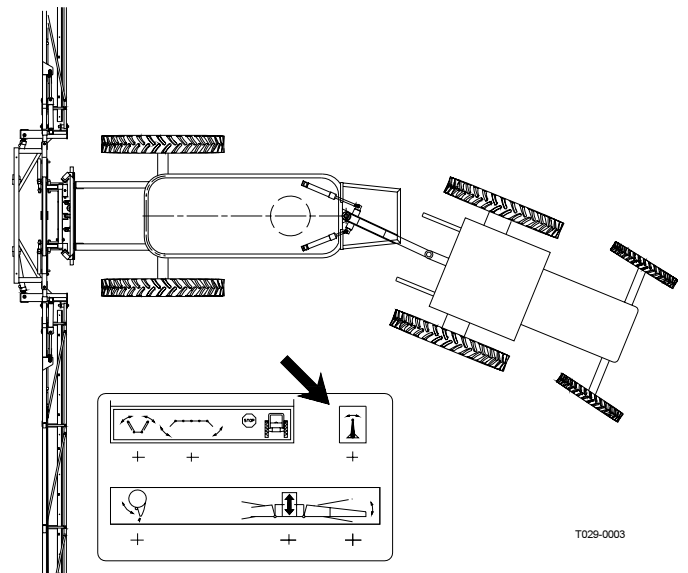

SELF TRACK

The SELF TRACK is always in tracking mode. The SELF TRACK drawbar will always articulate when the tractor is turning and follow the tractor rear wheels. The SELF TRACK drawbar is hydraulically damped to obtain stable trailing.



WARNING! Always drive the SELF TRACK very carefully on public roads, and be aware of the sprayer behaviour. Slow down before turning, to avoid the vehicle from tipping over.

MULTI TRACK

The MULTI TRACK has three modes:

1. Tracking mode

Set lever in tracking mode by pushing the handle backward and the MULTI TRACK drawbar will articulate to track with the tractor rear wheels.

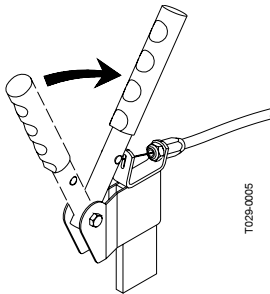

T029-0005

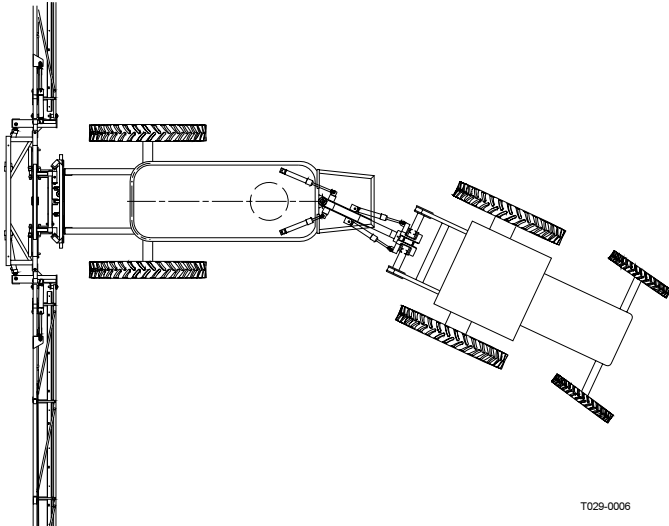

T029-0006

2. Normal trailing mode

Set the lever in normal trailing mode by pushing the handle forward and the MULTI TRACK will trail as a conventional trailer.

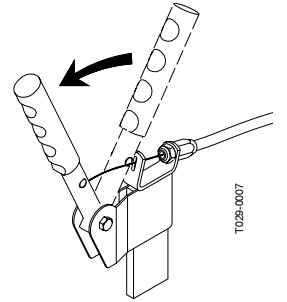

T029-0007

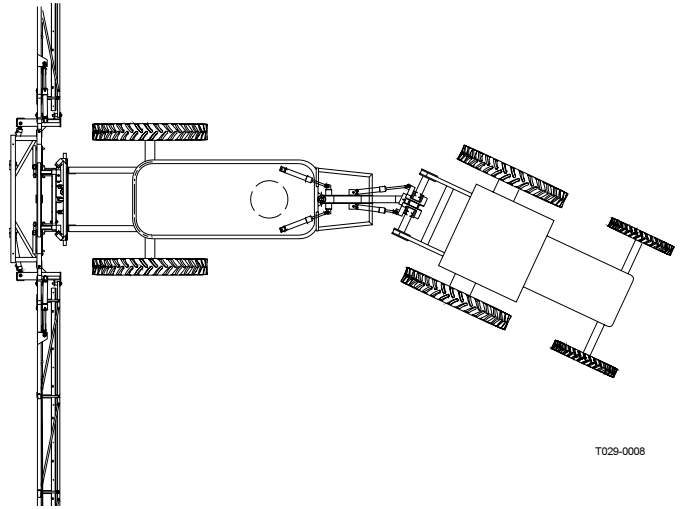

T029-0008

3. Track correction mode

When the lever is set in Tracking mode the switch at the D.A.H. control box can be activated sideways to off-set the trailing. This is used for track correction on hilly terrain.

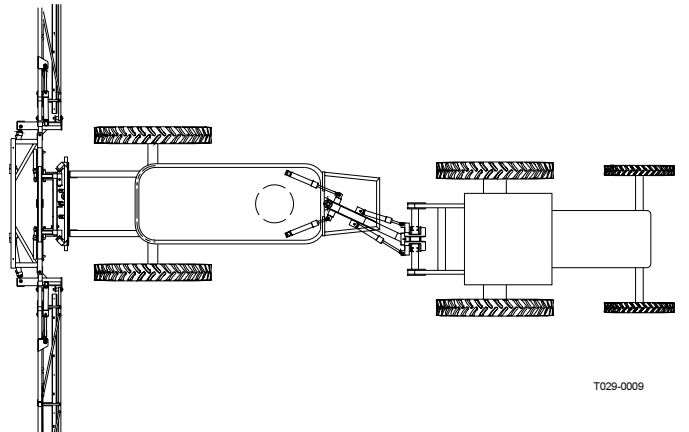

T029-0009

NOTE! The MULTI TRACK drawbar must always be aligned before changing from tracking mode to normal trailing mode and vice-versa.

IMPORTANT! Always set the MULTI TRACK in normal trailing mode when driving on public roads.

Operating instructions

Operating the boom



WARNING! Before unfolding the boom it is important to connect the tractor to prevent overbalancing of the sprayer.

DANGER! When folding and unfolding the boom, be sure that no persons or objects are in the operating area of the boom and that the boom cannot touch any electrical conductors.

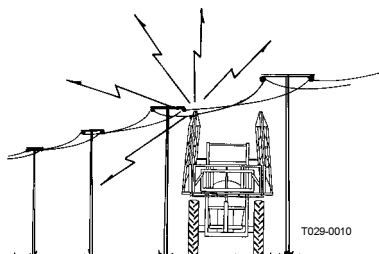

OLH boom and OLV boom

Boom manoeuvring:

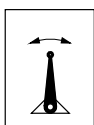
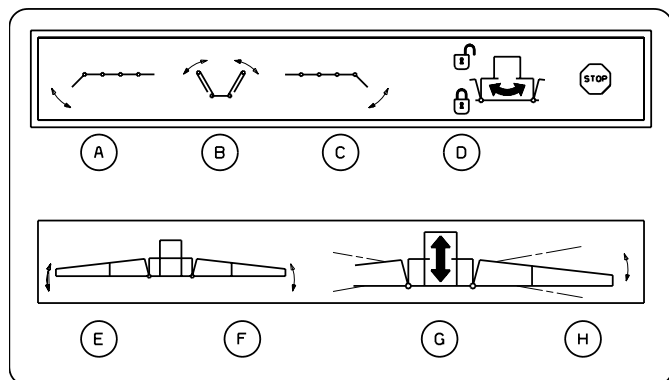

I

- A. Unfolding/folding of the left outer section
- B. Unfolding/folding of the inner section
- C. Unfolding/folding of the right outer section
- D. Pendulum locking device
- E. Boom Tilt, left side (OLH only)
- F. Boom Tilt, right side (OLH only)
- G. Boom lift, up/down
- H. Slanting control, pendulum
- I. Drawbar mode (MULTI TRACK + STEER TRACK only)

Unfolding of OLH and OLV boom

To unfold the boom, carry out following procedure:

1. Push boom lift switch **G** up-wards to lift the boom clear of the rear transport brackets.

NOTE! Ensure that the booms are clear from the transport brackets before unfolding is proceeded.

2. Lift the right and left boom parts by activating the boom tilt function, switch **E** and **F**
3. Push switch **B** to unfold the inner sections completely
4. Push switch **A** and **C** to unfold outer sections completely
5. Push switch **G** down-wards to lower the boom to approximately 50 cm above crop- or ground level.
6. Unlock the pendulum suspension by pushing switch **D** upwards.

NOTE! The upper functions (in the red rectangle with STOP sign) must only be operated when the sprayer is stationary. Failure to do so will damage the boom!

Folding of OLH and OLV boom

When folding the boom, carry out following procedure:

1. Raise boom lift **G** to upper position.
2. Check that trapeze slanting control is in levelled to middle position - if not correct by activating switch **H**.
3. Lock pendulum locking device by pushing switch **D** downwards.
4. Fold outer sections, **A** and **C**.
5. Lift up right and left hand side boom by activating right and left boom tilt, **E** and **F**.
6. Fold inner sections by activating switch **B**.
7. Lower boom lift, **G**, until boom rests on rear transport brackets.
8. Lower right and left boom side until they touches the front transport brackets, by activating boom tilt **E** and **F**.

OLS boom

The OLS boom is equipped with I.A.H. system. The boom is operated via a joystick, mounted to the tractor's remote control lever in the tractor cabin.

This joystick must be connected to:

1. The hydraulic system
2. The power supply

On top of the joystick is placed a label, which refers to the four function buttons of the joystick.

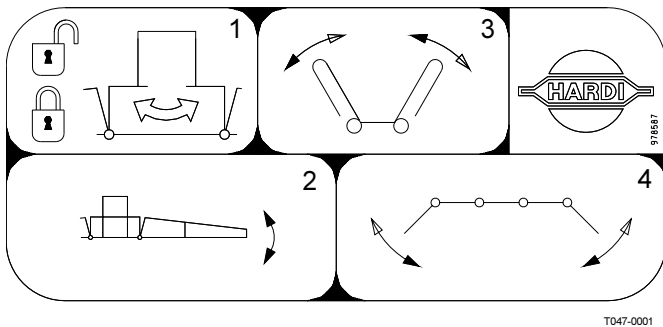

1. Pendulum locking device
2. Slanting control
3. Unfolding/folding of inner sections
4. Unfolding/folding of outer sections

To unfold the OLS boom:

1. Lead the joystick forward/backward¹ to lift the boom clear of the transport brackets. Keep the joystick in this position while performing the following steps.

NOTE! Ensure that the booms are clear of the transport brackets, before unfolding is proceeded.

2. Press button 3 to unfold inner sections completely.
3. Press button 4 to unfold outer sections completely.
4. Lower the boom lift to correct working height (appr. 50 cm (20 in) above ground or crop).
5. Unlock the pendulum by activating button 1.

To fold the OLS boom:

1. Raise boom lift to upper position by leading the joystick forwards/backwards¹.
2. Check that the slanting control is in neutral position (midway) - if not, correct it by activating button 2.
3. Lock pendulum locking device by pushing button 1.
4. Press button 4 to unfold outer sections.
5. Press button 3 to unfold inner sections.
6. Lower boom lift until boom rests in the transport brackets.



WARNING! When driving on public roads the tractor hydraulic remote control levers must be locked to avoid unintended unfolding of the boom.

NOTE! The boom must only be unfolded/folded when the vehicle is stationary. Failure to do so will damage the boom!

¹ The direction of the oil flow determines whether the joystick makes the boom move forward or backward. To alter the direction of these movements, either switch the hydraulic hoses around or set the control lever in the opposite position.

Operating instructions MANIFOLD SYSTEM

The MANIFOLD SYSTEM is located at the left side of the sprayer and permits operation of all HARDI optional extras from one position. The modular system facilitates the addition of up to three optional extras on the suction side and five extras on the pressure side. Furthermore the suction manifold can be fitted with a return valve which ensures better draining of the sprayer before cleaning.

Function diagram

1. Suction filter
2. Suction manifold (black)
3. Pump
4. Pressure manifold (green)
5. Return valve (blue)
6. Pressure agitator
7. On/off valve
8. Pressure adjustment
9. Self-Cleaning Filter
10. Safety valve
11. Distribution valves
12. Return from Pressure Equalisation
13. Check valve
14. Sprayer boom
15. Pressure gauge

EC (standard) 2200/2800

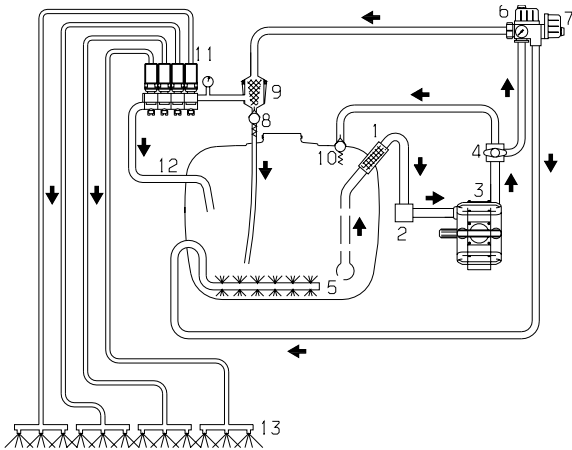

3200/4200

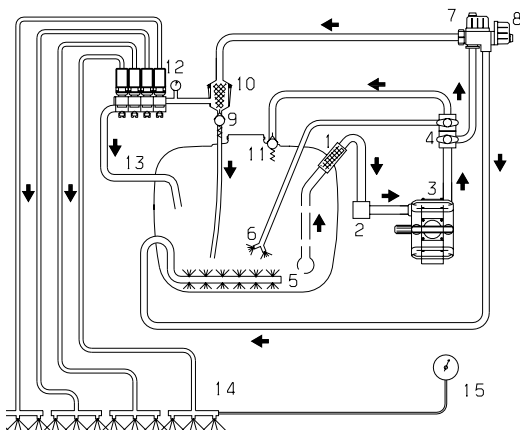

EC with optional equipment

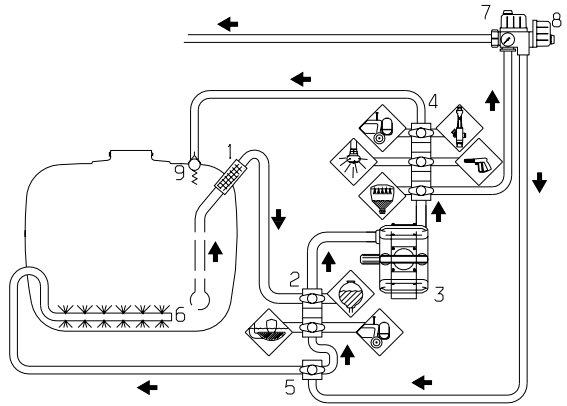

The diagram shows examples of options. These are individual for each sprayer.

Use of MANIFOLD valve system

The following pictograms and colours are used for the visualizing the function of the MANIFOLD valves:

- Green disc = Pressure valve
- Black disc = Suction valve
- Blue disc = Return valve

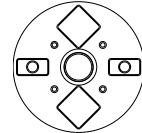

Green disc = Pressure valve

To Self-Cleaning
Filter/operating unit

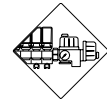

To Fast Filling Device

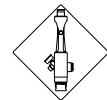

To HARDI FILLER



To Tank Flushing Nozzle

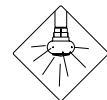

To main tank



Black disc = Suction valve

| | |
|---------------------------------|--|
| From main tank (suction filter) | |
| From Rinsing Tank | |
| From Filling Device | |

Blue disc = Return valve

| | |
|--|--|
| Agitation (spraying position) | |
| Pump suction line (to facilitate emptying the tank completely) | |

To operate the spraying functions:

- Turn the handle on a green pressure valve towards the function desired
- Turn the handle on a black suction valve towards the desired function
- Turn the handle on the blue return valve towards the desired direction of return flow
- Close all remaining valves by setting the handle(s) on "O"

IMPORTANT! The valves and functions may vary from machine to machine depending on optional equipment fitted. Only the functions to be used must be open - Always close remaining valves.

Electric operated MANIFOLD valves (if fitted)

One or more MANIFOLD valves can be electrically operated via a control box in the tractor cab. These can only be operated manually when the power to the valve motor is disconnected first.

Filling of water

Water can be filled into the main tank in following ways:

1. Filled through tank lid.
2. Filled by diaphragm pump through a suction side fitted filling device (optional extra) using normal pump

capacity directly to the tank.

3. Filled by diaphragm pump through a pressure side fitted injector/venturi type Fast Filling Device (optional extra) using up to 3 times normal pump capacity.
4. Combination of 2 and 3.

The tank should normally be filled 1/3 with water, before adding the chemicals - always read instruction on chemical container!

NOTE! Max. permitted tank contents:

| Model | Volume, Water litre (Imp. gal) | Volume Liquid fertilisers *) litre (Imp. gal) |
|-------|--------------------------------------|---|
| 2200 | 2200 (484) | 1690 (372) * |
| 2800 | 2800 (616) | 2000 (440) * |
| 3200 | 3200 (704) | 3200 (704) * |
| 4200 | 4200 (924) | 3231 (711) * |

*) Based on liquid fertilisers with specific gravity 1.3

Filling through tank lid

Remove tank lid and fill water through strainer to prevent rust or other particles to enter the tank.

An overhead tank can be used in order to obtain high filling capacity.

It is recommended to use as clean water as possible for spraying purposes.



WARNING! DO NOT LET FILLING HOSE ETC. ENTER THE TANK. KEEP IT OUTSIDE THE TANK, POINTING TOWARDS THE FILLING HOLE.

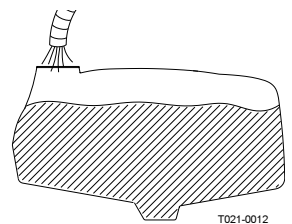
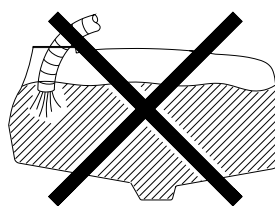

T021-0012

IF THE HOSE IS LEAD TO THE BOTTOM OF THE TANK, AND THE WATER PUMP AT THE WATER SUPPLY PLANT STOPS, CHEMICALS CAN BE SIPHONED BACK AND CONTAMINATE THE WATER SUPPLY LINES.

Suction Filling Device (if fitted)



WARNING! Avoid contamination or personal injury. Do not open suction valve towards Suction Filling Device unless pump is running and filling hose is connected. If this valve is opened without pump running, liquid will stream out of the MANIFOLD.

The Suction Filling Device is operated as follows:

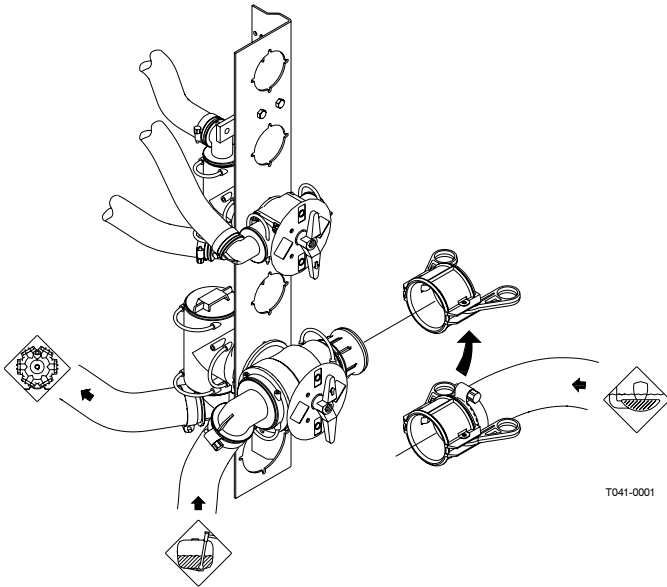

T041-0001

1. Remove cover **A**, and connect suction hose **B** to Suction Manifold.
2. Engage diaphragm pump and set P.T.O. revolutions at 540 r/min. Turn handle on Suction Manifold towards Filling Device.

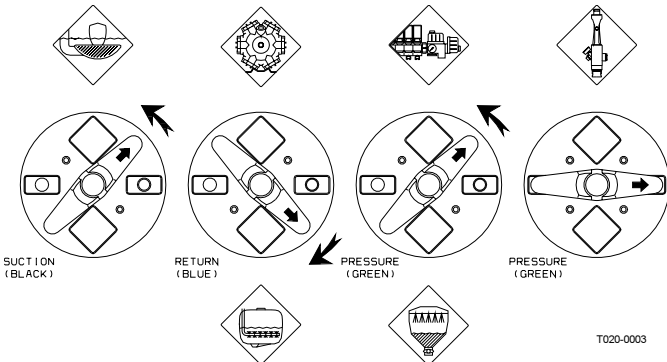

T020-0003

3. The tank is now filled with water. Keep an eye on liquid level indicator.
4. Turn handle on Suction Manifold away from Filling Device to discontinue filling process. Then disengage pump.
5. Disconnect suction tube **B** and replace cover.

NOTE! Observe local legislation regarding use of Filling Device. In some areas it is prohibited to fill from open water reservoirs (lakes, rivers etc.). It is recommended only to fill from closed reservoirs (mobile water tanks etc.) to avoid contamination.



WARNING! If suction hose/filter is carried on the sprayer during spraying, it can be contaminated by spray drift which will be transferred to lake/river when filling!

1. Remove cover **A**, and connect suction hose **B** to Suction Manifold.

2. Engage diaphragm pump and set P.T.O. revolutions at 540 r/min. Turn handle on Suction Manifold towards Filling Device.
3. The tank is now filled with water. Keep an eye on liquid level indicator.
4. Turn handle on Suction Manifold away from Filling Device to discontinue filling process. Then disengage pump.
5. Disconnect suction tube **B** and replace cover.

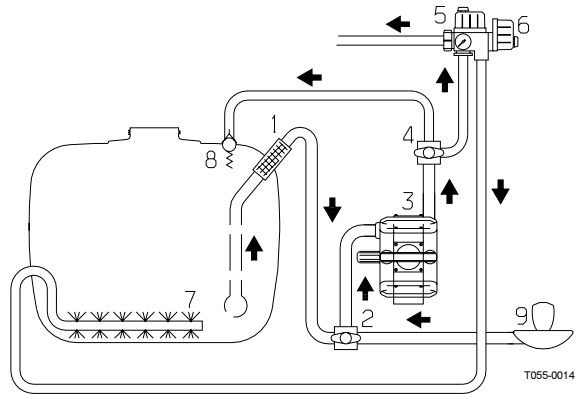

T055-0014

NOTE! Observe local legislation regarding use of Filling Device. In some areas it is prohibited to fill from open water reservoirs (lakes, rivers etc.). It is recommended only to fill from closed reservoirs (mobile water tanks etc.) to avoid contamination.



WARNING! If suction hose/filter is carried on the sprayer during spraying, it can be contaminated by spray drift which will be transferred to lake/river when filling!

Fast Filling Device (if fitted)

The Fast Filling Device is operated as follows:

1. Ensure spray liquid tank contains at least 50 litres of water.
2. Remove cover (**A**) and connect suction hose (**B**).
3. Turn handle on Pressure Manifold towards Fast Filler. With the P.T.O. at 540 r/min, the pressure gauge should indicate about 10 bar.
4. If water is not seen in transfer tube, prime by turning valve (**C**).
5. Keep eye on liquid level indicator.
6. Turn handle on Pressure Manifold away from Fast Filler to discontinue filling process.

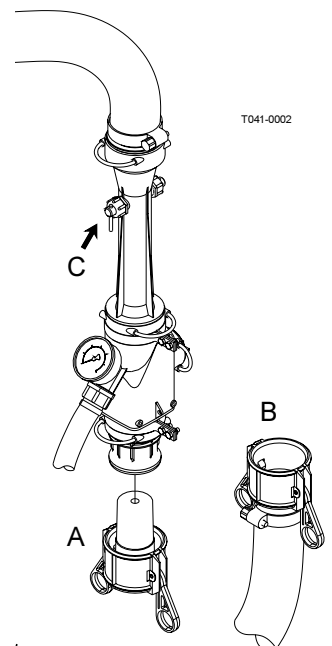

T041-0002

NOTE: Turn handle towards EC-operating unit **before** turning away from Fast Filler in order to avoid peak pressure blowing the safety valve!

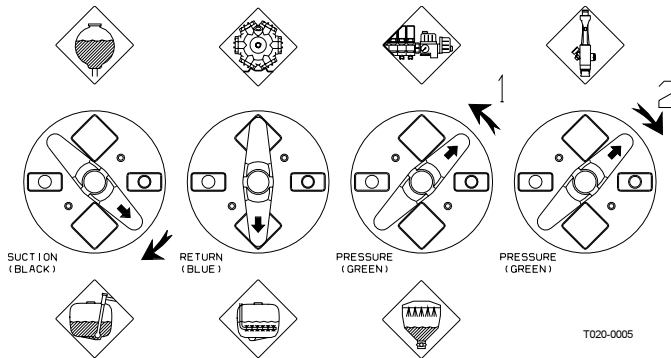

T020-0005

7. Disconnect suction tube (B) and replace cover.

The Filling Device and the Fast Filling Device can be used simultaneously - this gives even bigger filling capacity.

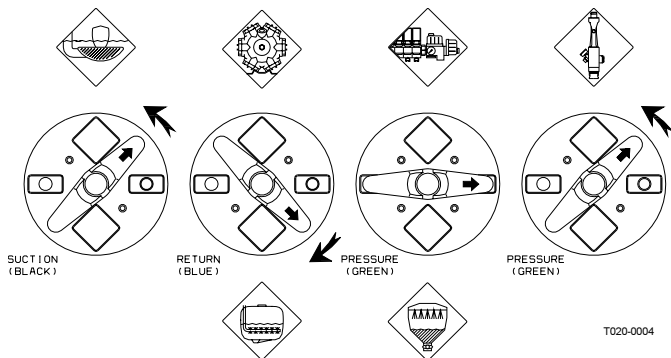

T020-0004



WARNING: Do not leave the sprayer whilst refilling the tank, and keep an eye on the level gauge in order **NOT** to overflow the tank!

NOTE! Observe local legislation regarding use of Filling Device. In some areas it is prohibited to fill from open water reservoirs (lakes, rivers etc.). It is recommended only to fill from closed reservoirs (mobile water tanks etc.) to avoid contamination.

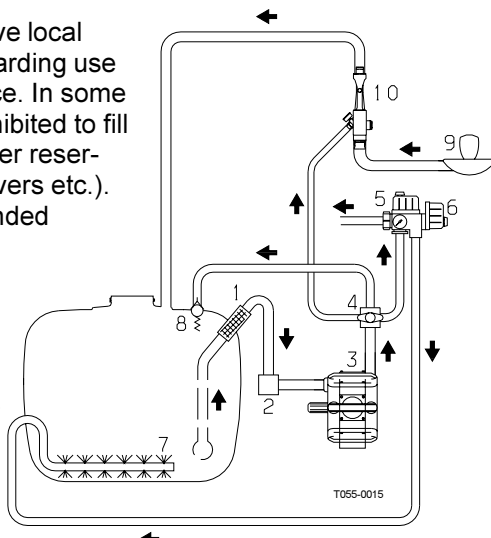

T055-0015



WARNING! If suction hose/filter is carried on the sprayer during spraying, it can be contaminated by spray drift, which will be transferred to lake/river when filling!

Filling of rinsing tank (if fitted)

The rinsing tank is situated at the front under the platform and main tank.

3200/4200

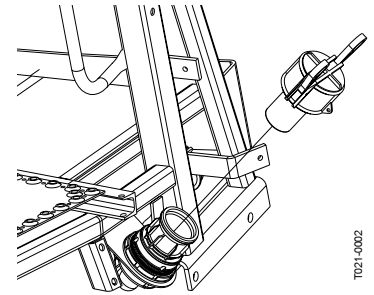

T021-0002

Access to the rinsing tank lid goes through the hatch in the platform. Only fill with clean water.

2200/2800

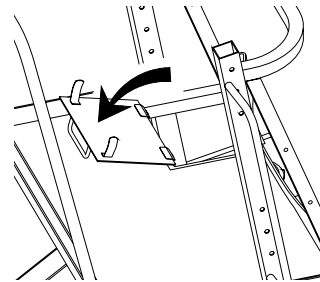

T042-0005

Capacities are:

| Model | Rinsing tank capacity | | |
|-----------|-----------------------|-----------|---------|
| | l | imp. Gal. | US Gal. |
| 2200/2800 | 260 | 57 | 70 |
| 3200/4200 | 460 | 101 | 120 |

Filling of clean water tank

The clean water tank has a capacity of 15 l (3.3 Imp. gal). The water from this tank is for hand washing, cleaning of clogged nozzles etc. Only fill this tank with clean water from the well.



WARNING! Although the clean water tank is only filled with clean, it must never be used for drinking.

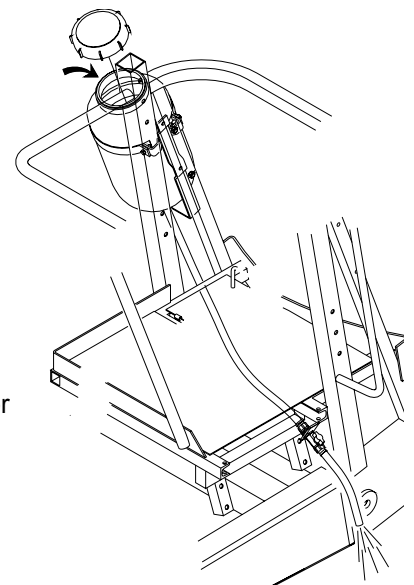

T042-0004

Adjustments of EC operating unit

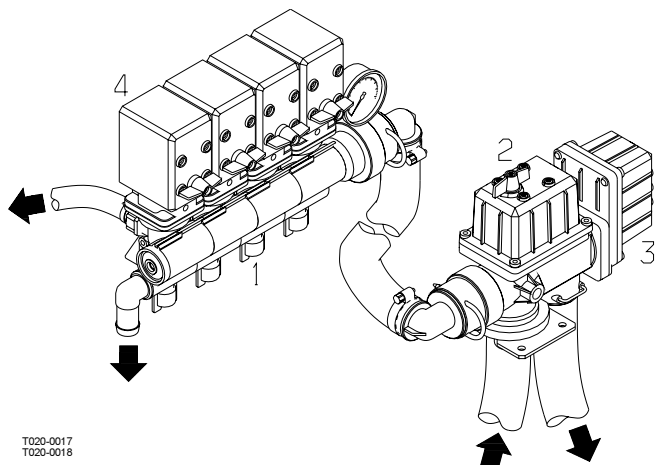

T020-0017
T020-0018

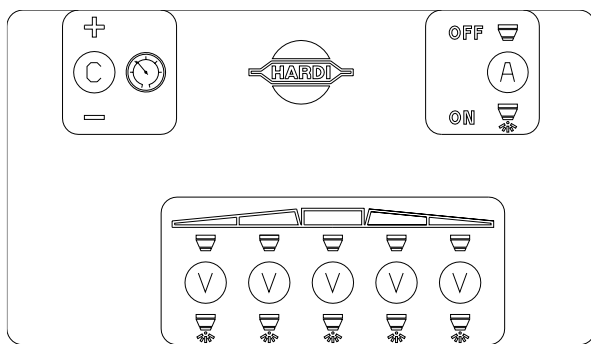

Before spraying the EC operating unit is adjusted using clean water (without chemicals).

1. Choose the correct nozzle for the spray job by turning the TRIPLET nozzle bodies. Make sure that all nozzles are the same type and capacity. See the "Spray Technique" book.
2. On-off switch **A** is activated against green.
3. All distribution valve switches **V** are activated against green.
4. Pressure regulation switch **C** is activated until emergency handle **3** stops rotating (minimum pressure).
5. Put the tractor in neutral and adjust the P.T.O. and thereby the number of revolutions of the pump corresponding to the intended travelling speed. Remember the number of revolutions on the P.T.O. must be kept between 300-600 rpm.
6. Pressure regulation switch **C** is activated until the required pressure is shown on the pressure gauge.

ADJUSTMENT OF PRESSURE EQUALISATION

1. Close the first distribution valve switch **V**.
2. Turn the adjusting screw **1** until the pressure gauge again shows the same pressure.
3. Adjust the other sections of the distribution valve in the same way.

NOTE! HEREAFTER ADJUSTMENT OF PRESSURE EQUALISATION WILL ONLY BE NEEDED WHEN:

1. YOU CHANGE TO NOZZLES WITH OTHER CAPACITIES
2. THE NOZZLE OUTPUT INCREASES AS THE NOZZLES WEAR

Operating the control unit while spraying

In order to close the entire boom, switch ON/OFF **A** to off position. This returns the pump output to the tank through the return system. The diaphragm Non-drip valves ensure instantaneous closing of all nozzles. In order to close one or more sections of the boom, switch the relevant distribution valve **V** to off position. The pressure equalisation ensures that the pressure does not rise in the sections which are to remain open.

When the sprayer is put aside, the control box and the multi plug must be protected against moisture and dirt. A plastic bag may be used to protect the multi plug.

Remote pressure gauge (if fitted)

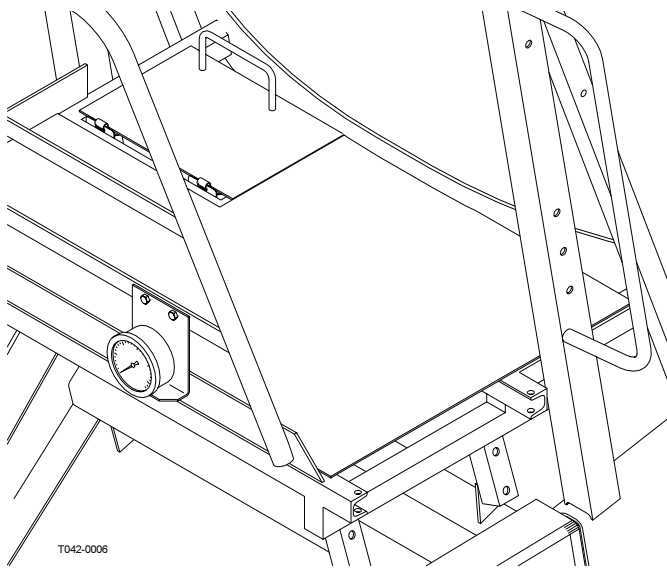

The remote pressure gauge measures the working pressure in the boom tubes as close to the nozzles as possible. This pressure reading will always be slightly lower than the reading at the operating unit pressure gauge.

The outputs stated in the nozzle charts are always based on the pressure measured at the nozzle.

Always adjust pressure when calibrating and spraying according to readings at the Remote pressure gauge.

Filters

All filters should always be used, and their function checked regularly. The mesh size of the filter in use should always be smaller than the flow average of the

nozzles used. Therefore, pay attention to the correct combination of filters, mesh size.

Self-cleaning filter
Operating diagram

1. From pump
2. Double filter screen
3. Guide cone
4. To operating unit
5. Replaceable restrictor
6. Return to tank
7. Screw-joint

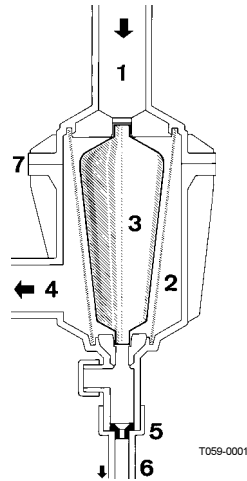

IMPORTANT! The ball valve underneath the self-cleaning filter should normally be open, but must be closed in the following cases:

1. If rinsing with water from the rinsing tank and a quantity of spray liquid still remains in the main tank (otherwise the spray liquid will be diluted).
2. If opening the self-cleaning filter and a quantity of spray liquid still remains in the main tank (otherwise there is a risk that spray liquid will flow out).

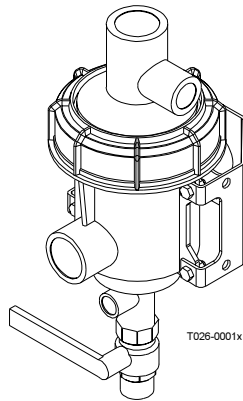

Choice of correct restrictor

It is important to have a large flow through the filter. This is achieved by choosing the restrictor size in relation to the liquid consumption of the spray boom.

4 restrictors are supplied. Use the green one (largest orifice) first.

The hose **N** is demounted at the self-cleaning filter, the restrictor is put in the hose and the hose is mounted again. If the required working pressure cannot be obtained, the restrictor is too large. Choose a smaller restrictor. Start with a black one, then a white and finally a red one.

When cleaning the filter remove hose **N**

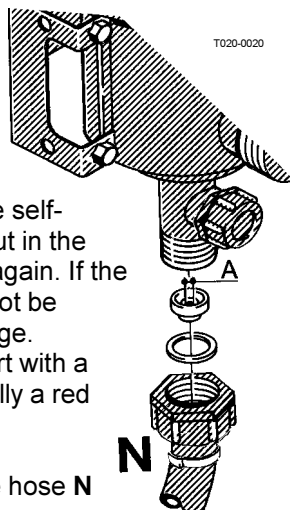

and the hose at the safety valve, and check there are no residues.

Standard filter size is 80 mesh. Sizes of 50 and 100 mesh are available and can be changed by opening the filter top, and replace the strainer. Check the O-rings before reassembling the filter and replace if damaged.

Filling of chemicals.

Chemicals can be filled in the tank in 2 ways:

1. Through tank lid.
2. By means of HARDI FILLER chemical filling device.

Filling through tank lid

The chemicals are filled through the tank lid - Note instructions on the chemical container!



WARNING! Be careful not to slip or splash chemicals when carrying chemicals up to the tank lid!

1. Make sure the EC on/off valve is switched off.
2. Set the MANIFOLD valves to correct position. Black valve "Suction from main tank", green valve towards "Agitation" and Blue valve towards "Agitation".

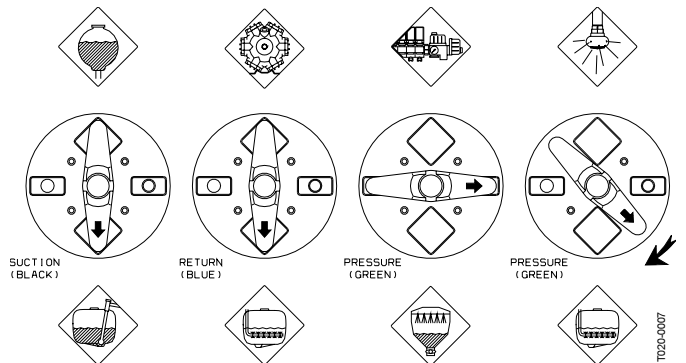

3. Engage the pump and set P.T.O. revs. to 540 r.p.m.
4. Add the chemicals through the main tank hole.
5. When the spray liquid is well mixed, turn handle on the Pressure Manifold towards "Spraying" position. Keep P.T.O. engaged so the spray liquid is continuously agitated until it has been sprayed on the crop.

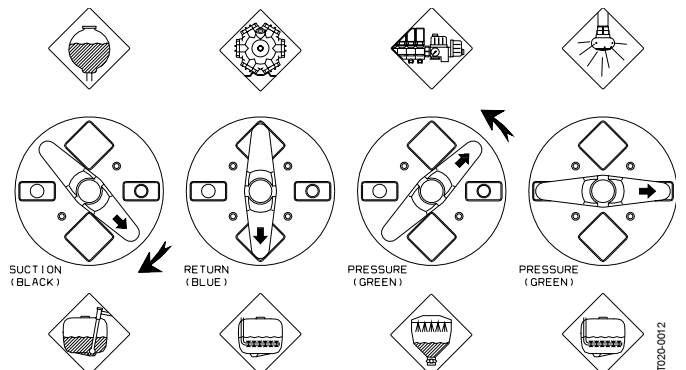

Filling by HARDI FILLER chemical inductor Liquid chemicals

1. Fill the main tank at least $\frac{1}{3}$ with water (unless something else is stated on the chemical container label). See section "Filling of water".
2. Turn the handle at the Suction Manifold towards "Main tank" and turn blue return valve towards "Agitation". Close remaining valves.
3. Turn the handle at the Pressure Manifold towards "HARDI FILLER". Close remaining valves. Check that bottom valve **A** at the FILLER is closed.

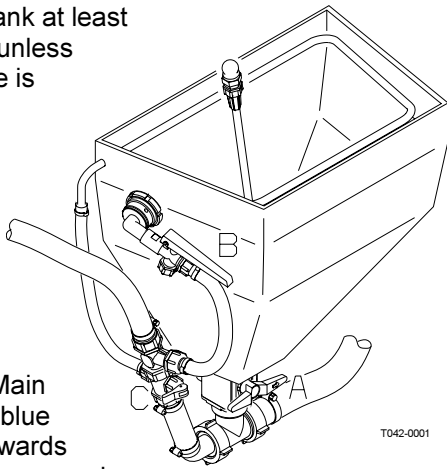

T042-0001

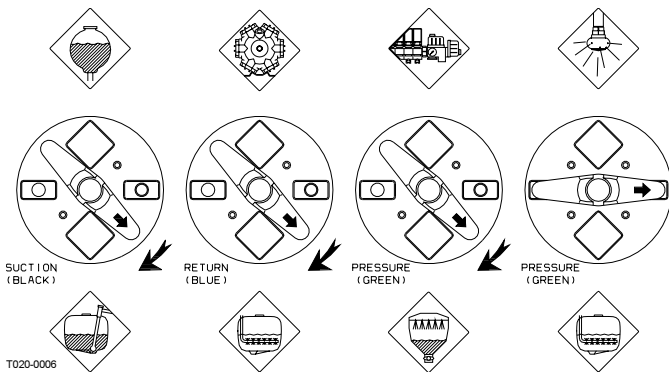

T020-0006

4. Engage the pump and set P.T.O. speed at 540 r.p.m.
5. Open FILLER lid.
6. Measure the correct quantity of chemical and fill it into the hopper.

NOTE! The scale in the hopper can only be used if the sprayer is parked at level ground! It is recommended to use a measuring jug for best accuracy.

7. Open the bottom valve **A** and the chemical is transferred to the main tank.
8. If the chemical container is empty it can be rinsed by the container rinsing device (if fitted). Place the container over the multi-hole nozzle and press the lever **B**.



WARNING! Do not press lever **B** unless the multi-hole nozzle is covered by a container to avoid spray liquid hitting the operator.

IMPORTANT! Rinsing device uses spray liquid to rinse containers for concentrated chemicals. Always rinse the chemical containers with clean water several times until

they are clean before disposal.

9. Engage the hopper rinsing device by opening valve **C**.
10. Close valve **C** again when the hopper is rinsed.

IMPORTANT! The hopper rinsing device is using spray liquid for rinsing the hopper for concentrated chemical! The FILLER must always be cleaned together with the rest of the sprayer when the spray job is done.

11. Close valve **A** and the FILLER lid again.
12. Turn handle at the Pressure Manifold towards "Intensive Agitation" and close remaining valves.

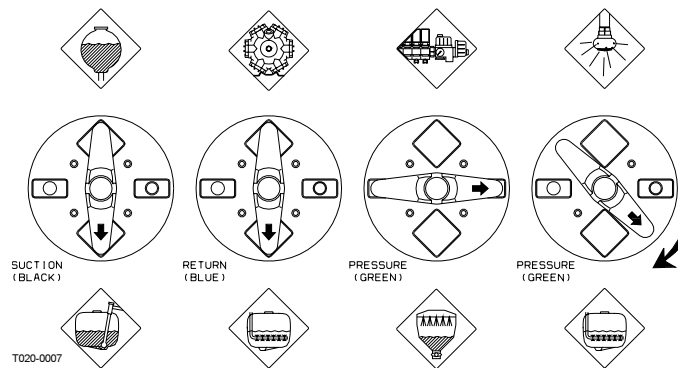

T020-0007

13. When the spray liquid is well mixed, turn handle on the Pressure Manifold towards "Spraying" position. Keep P.T.O. engaged so the spray liquid is continuously agitated until it has been sprayed on the crop.

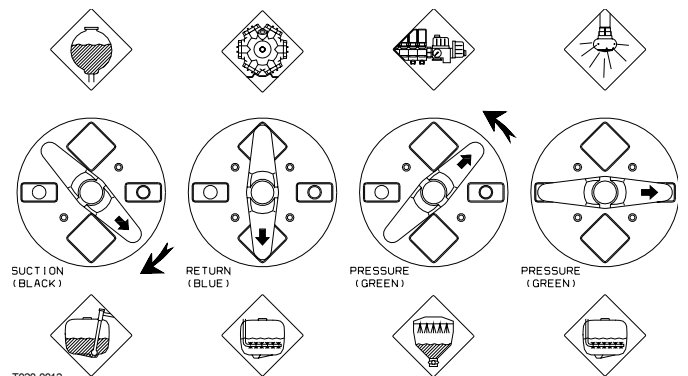



T020-0012

Powder chemicals

Filling of powder chemicals is done as follows:

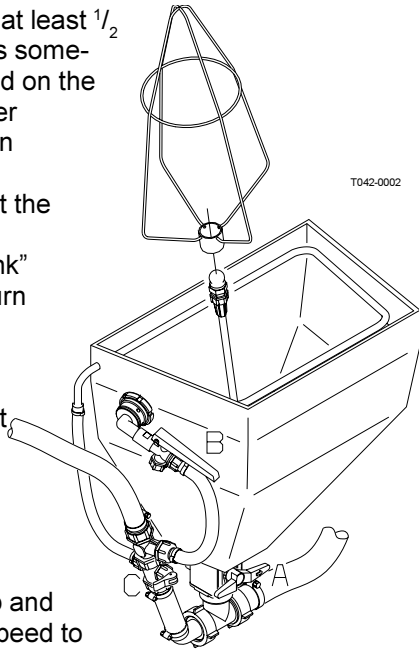
1. Fill the main tank at least $\frac{1}{2}$ with water (unless something else is stated on the chemical container label). See section "Filling of water".
2. Turn the handle at the Suction Manifold towards "Main tank" and turn blue return valve towards "Agitation". Close remaining valves.
3. Turn the handle at the Pressure Manifold towards "HARDI FILLER". Close remaining valves.
4. Engage the pump and increase P.T.O. speed to 540 r.p.m.
5. Open the bottom valve **A** at the FILLER. Open FILLER lid.
6. Engage the hopper rinsing device by opening valve **C**.
7. Measure the correct quantity of chemical and sprinkle it into the hopper as fast as the rinsing device can flush it down.
8. If the chemical container is empty it can be rinsed by the container rinsing device (if fitted). Fit the bag bracket and place the powder bag over the multi-hole nozzle and press the lever **B**.



 **WARNING!** Do not press lever **B** unless the multi-hole nozzle is covered by a container to avoid spray liquid hitting the operator.

IMPORTANT! Rinsing device uses spray liquid to rinse containers for concentrated chemicals. Always rinse the chemical containers with clean water several times until they are clean before disposal.

9. Close valve **C** again when the hopper is rinsed.

IMPORTANT! The hopper rinsing device is using spray liquid to rinse the hopper for concentrated chemical. The FILLER must always be cleaned together with the rest of the sprayer when the spray job is done.

10. Close valve **A** and the FILLER lid again.
11. Turn handle at the Pressure Manifold towards "Intensive Agitation" and close remaining valves to mix the spray liquid.

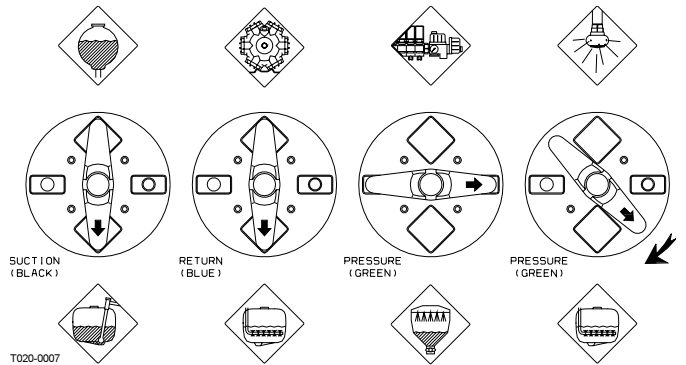

12. When the spray liquid is well mixed, turn handle on the Pressure Manifold towards "Spraying" position. Keep P.T.O. engaged so the spray liquid is continuously agitated until it has been sprayed on the crop.

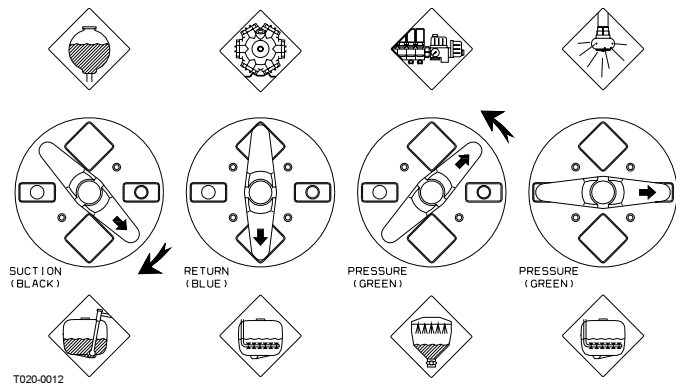

Use of rinsing tank and rinsing nozzles (if fitted)

The incorporated 260 l (57 Imp.gal) rinsing tank can be used for two different purposes.

A. In-field diluting of remaining spray liquid residues in the spraying circuit for spraying the liquid in the field, before cleaning the sprayer.

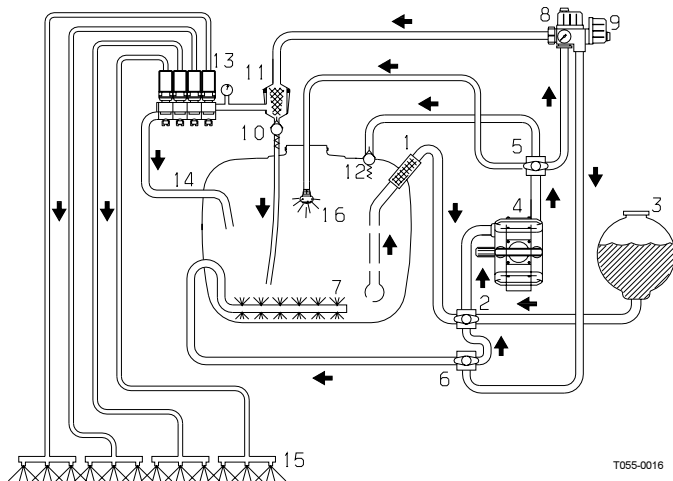

1. Empty the sprayer as much as possible. Turn the blue valve 6 towards pump and spray till air comes out of all nozzles.
2. Remove the tank filter basket.
3. Turn suction valve 2 towards rinsing tank.
4. Turn pressure valves 5 towards rinsing nozzle (if fitted).
5. Engage and set the pump at appr. 300 r.p.m.
6. When rinsing water corresponding to appr. 10 times the spray liquid residue (see paragraph "Technical Residue") is used, turn back suction valve towards suction from main tank and operate all valves, so all hoses and components are rinsed.
7. Turn pressure valve 5 back to EC operating unit and spray liquid in the field you have just sprayed.
8. Repeat point 3-7 until the rinsing tank is empty.

B. Rinsing the pump, operating unit, spray lines, etc. in case of stop in spraying before main tank is empty (e.g. beginning rain etc.).

1. Close ball valve underneath the self-cleaning filter.

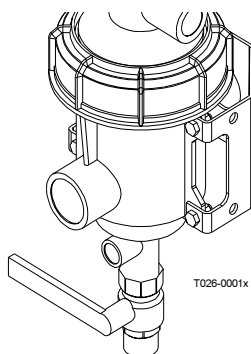

2. Turn suction valve 2 towards rinsing tank.
3. Turn blue return valve 6 (if fitted) towards pump suction line.
4. Engage the pump and spray water from rinsing tank in the field until all nozzle tubes/nozzles are flushed with clean water.
5. Disengage pump again.
6. Open ball valve again.



WARNING! The rinsing nozzles cannot always guarantee a 100% cleaning of the tank. Always clean manually with a brush afterwards, especially if crops sensitive to the chemical just sprayed are going to be sprayed afterwards!

Technical Residue

Inevitably a quantity of spray liquid will remain in the system, which cannot be sprayed properly on the crop, as the pump takes in air when the tank is about to be empty.

This Technical Residue is defined as the remaining liquid qty. in the system as the first clear pressure drop on the pressure gauge is read.

| | Residue, litre (Imp gal) | | | |
|--------------------------------|--------------------------|--------------------|---------------------------|---------------------|
| | With Blue Return Valve | | Without Blue Return Valve | |
| | 2200/2800 | 3200/4200 | 2200/2800 | 3200/4200 |
| Dilutable residue ¹ | 5-10 (1.1-2.2) | 13-20 (2.9-4.4) | 15-20 (3.3-4.4) | 28-41 (6.2-9.0) |
| Total residue ² | 30-38 (6.6-8.4) | 26-33 (5.7-7.3) | 40-48 (8.8-10.6) | 41-54 (9.0-11.9) |

Chart 003

- 1) Residue in main tank, possible to dilute with water from rinsing tank
- 2) Total residue in tank and spraying circuit on standard sprayer. Variations due to different ground inclinations etc.

The dilutable residue must be diluted 10 times with clean water and sprayed to the crop just sprayed before cleaning the sprayer - See paragraph "Cleaning".

Operation of the tank drain valve

Pull the string at left hand side of the tank to open the drain valve. The valve is spring-loaded but can be kept open by pulling the string out and upwards in the V-shaped slit.

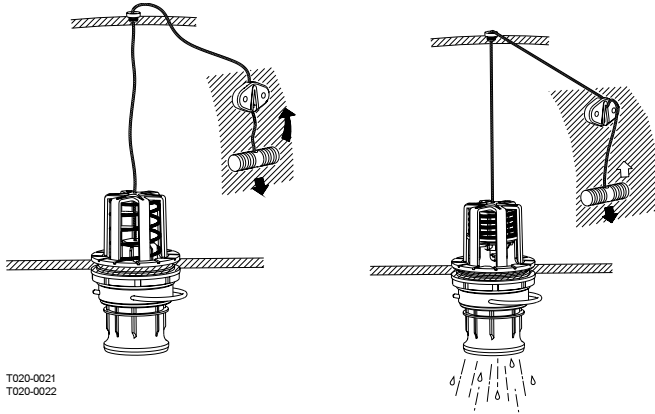

To release and close the drain valve again pull the string downwards and the valve will close automatically.

If draining a residue, e.g. liquid fertilisers into a reservoir, a snap coupler with hose can rapidly be connected to the drain valve, and the liquid let safely out.

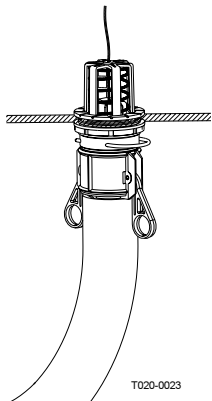

Rinsing tank drain valve

To avoid algae developing in the rinsing tank always drain the rinsing tank when the sprayer is not in use for a long period.

Spray Technique - see separate book

Safety precautions



Always be careful when working with crop protection chemicals!

Personal protection

Dependant on which type of chemical used, the following protective clothing/equipment should be used:

- Gloves
- Waterproof boots
- Headgear
- Respirator
- Safety goggles
- Chemical resistant overall

This equipment should be worn to avoid contact with the chemicals!

- Protective clothing/equipment should be used when preparing the spray liquid, during the spraying work and when cleaning the sprayer. Also follow the recommendations on the chemical label.
- It is always advisable to have clean water available, especially when filling the sprayer with the chemical.
- Always clean the sprayer carefully and immediately after use.
- Do not mix different chemicals in the tank.
- Always clean the sprayer before changing to another chemical.

Disconnecting the sprayer

Always clean the sprayer - inside and outside - before disconnecting and parking it.

Before disconnecting from the tractor, make sure the support leg is properly fitted.



WARNING! To prevent the sprayer from tipping over, do not disconnect the sprayer from the tractor with the booms unfolded unless the boom is supported!

Always engage the parking brake (if fitted).

If no parking brake is fitted, or if local regulations requires so, place stop wedges in front of and behind the wheels.

Remember to disconnect all hoses and cables from the tractor.



WARNING! If the sprayer is parked unattended avoid unauthorised persons, children and animals having access to the sprayer.

Hose package and transmission shaft support

To prevent hoses and wiring from being damaged by the tractor wheels, all hoses, cables and wires are held by the hose bracket fitted to the drawbar. Check the length of the hoses and cables are sufficient by tight turns.

The transmission shaft is placed in the hook when not in use.

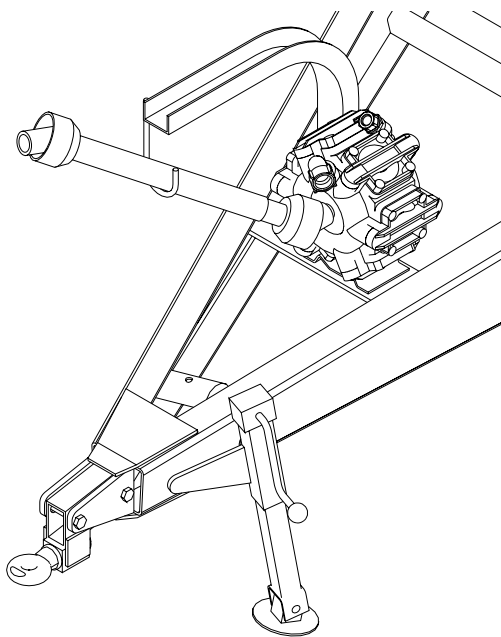

T046-0001



Maintenance

In order to derive full benefit from the sprayer for many years the following service and maintenance program should be followed.

IMPORTANT! Always read the individual paragraphs. Read instructions for service/maintenance jobs carefully through before starting on the job. If any portion remains unclear or require facilities which are not available, then for safety reasons please leave the job to your HARDI dealers workshop.

Cleaning the sprayer

Guidelines

Read the whole chemical label. Take note of any particular instructions regarding recommended protective clothing, deactivating agents, etc. Read the detergent and deactivating agent labels. If cleaning procedures are given, follow them closely.

Be familiar with local legislation regarding disposal of pesticides washings, mandatory decontamination methods, etc. Contact the appropriate department, e.g. Dept of Agriculture.

Pesticide washings can usually be sprayed out on a soakaway. This is an area of ground that is not used for cropping. You must avoid seepage or run-off of residue into streams, water courses, ditches, wells, springs, etc. The washings from the cleaning area must not enter sewers. Drainage must lead to an approved soakaway.

Cleaning starts with the calibration, as a well calibrated sprayer will ensure the minimal amount of remaining spray liquid.

It is good practice to clean the sprayer immediately after use and thereby rendering the sprayer safe and ready for the next pesticide application. This also prolongs the life of the components.

It is sometimes necessary to leave spray liquid in the tank for short periods, e.g. overnight, or until the weather becomes suitable for spraying again. Unauthorised persons and animals must not have access to the sprayer under these circumstances.

If the product applied is corrosive, it is recommended to coat all metal parts of the sprayer before and after use with a suitable rust inhibitor.

Remember: Clean sprayers are safe sprayers.
Clean sprayers are ready for action.
Clean sprayers cannot be damaged by pesticides and their solvents.

Cleaning

1. Dilute remaining spray liquid in the tank with at least 10 parts of water and spray the liquid out in the field you have just sprayed - See paragraph "Use of rinsing

tank and rinsing nozzles". **NOTE:** It is advisable to increase the forward speed (double if possible) and reduce the pressure. For S4110 nozzles, pressure may be reduced to 1.5 bar (20 psi).

2. Select and use the appropriate protective clothing. Select detergent suitable for cleaning and suitable deactivating agents if necessary.
3. Rinse and clean sprayer and tractor externally. Use detergent if necessary.
4. Remove tank and suction filters and clean. Be careful not to damage the mesh. Replace suction filter top. Replace filters when the sprayer is completely clean.
5. With the pump running, rinse the inside of the tank. Remember the tank roof. Rinse and operate all components and any equipment that has been in contact with the chemical.

Before opening the distribution valves and spraying the liquid out, decide whether this should be done in the field again or on the soakaway.

6. After spraying the liquid out, stop the pump and fill at least $\frac{1}{5}$ of the tank with clean water. Note that some chemicals require the tank to be completely filled. Add appropriate detergent and/or deactivating agent, e.g. Washing soda or Triple ammonia.

NOTE: If a cleaning procedure is given on the chemical label, follow it closely.

7. Start the pump and operate all controls enabling the liquid to come in contact with all the components. Leave the distribution valves until last. Some detergents and deactivating agents work best if left in the tank for a short period. Check the label. The Self-Cleaning Filter can be flushed by removing the by-pass hose from the bottom of the filter. Stop the pump and remove the hose. Start the pump for a few seconds to flush filter. Be careful not to lose the restrictor nozzle.
8. Drain the tank and let pump run dry. Rinse inside of tank, again letting the pump run dry.
9. Stop the pump. If the pesticides used have a tendency to block nozzles and filters, remove and clean them now. Check also for sediment on the pressure side of the safety valve for the Self-Cleaning Filter.
10. Replace all the filters and nozzles and store the sprayer. If, from previous experiences, it is noted that the solvents in the pesticide are particularly aggressive, store the sprayer with the tank lid open.

NOTE! If the sprayer is cleaned with a high pressure cleaner lubrication of the entire machine is recommended.

Cleaning and maintenance of filters



Clean filters ensure:

- Sprayer components such as valves, diaphragms and operating unit are not hindered or damaged during operation.
- Nozzle blockages do not occur whilst spraying.
- Long life of the pump. A blocked suction filter will result in pump cavitation.

The main filter protecting sprayer components is the suction filter at the top of the tank. Check it regularly.

Lubrication

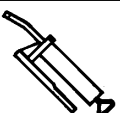
Following recommended lubricants are to be used.

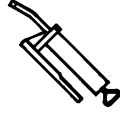
| Lubricating points | | Lubricant |
|--------------------|--|--|
| Ball bearings |  A | Universal Lithium grease, NLGI No. 2 SHELL RETINAX EP2 CASTROL LMX GREASE |
| Slide bearings |  B | Lithium grease with Molybdenumdisulphide or graphite SHELL RETINAX HDM2 CASTROL MOLYMAX |
| Oil lub. points |  C | TOTAL Transmission TM SAE 80W/90 Castrol EPX 80W/90 SHELL Spirax 80W/90 Mobil Mobilube 80W/90 |
| Yaw dampers |  D | Use a synthetic type of grease, e.g. silicone grease. Never use a compound containing kerosine or mineral oil. |

Always store lubricants clean, dry and cool - preferably at a constant temperature - to avoid contamination from dirt and condensed water.

Keep oil filling jugs, hoppers and grease guns clean, and clean the lubricating points thoroughly before lubricating.

Avoid skin contact with oil products for longer periods.

NOTE! If the sprayer is cleaned with a high pressure cleaner or fertiliser has been used, lubrication of all sections is recommended.

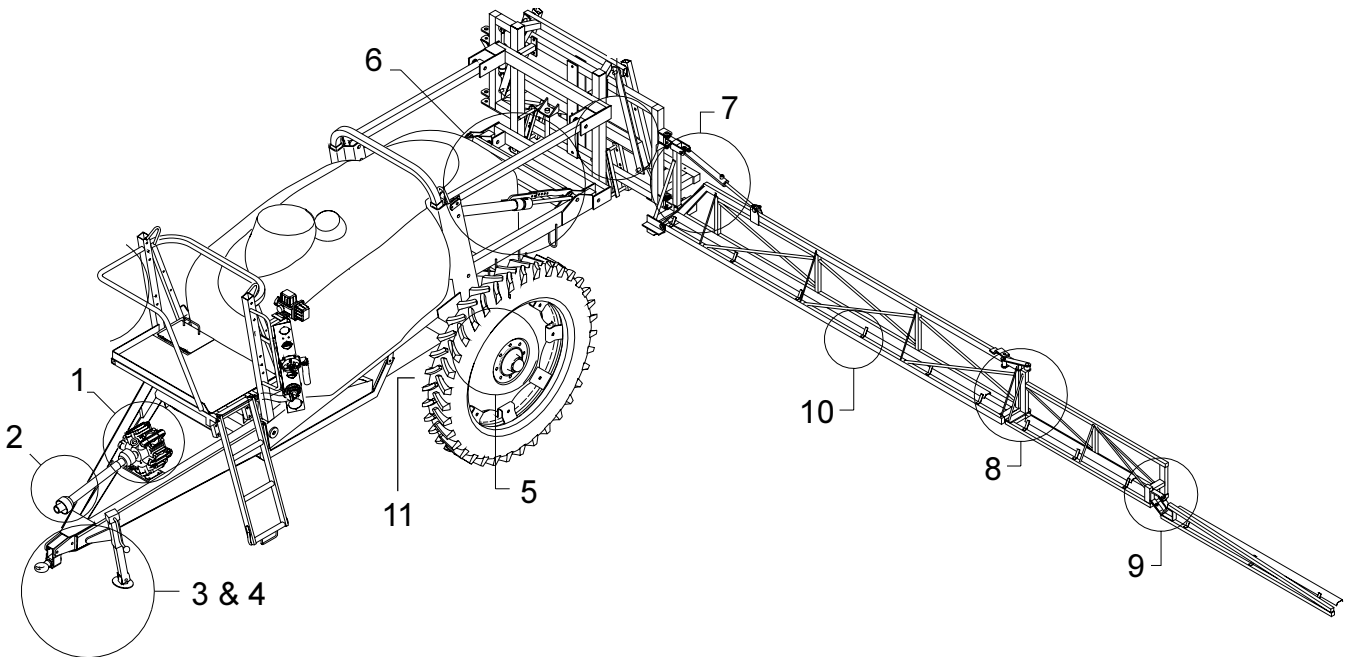
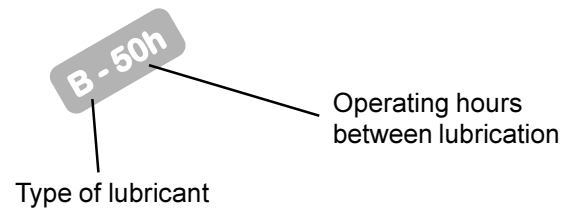

T212-0004

1

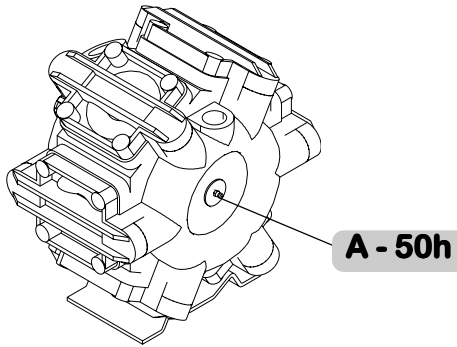

T201-0001

2

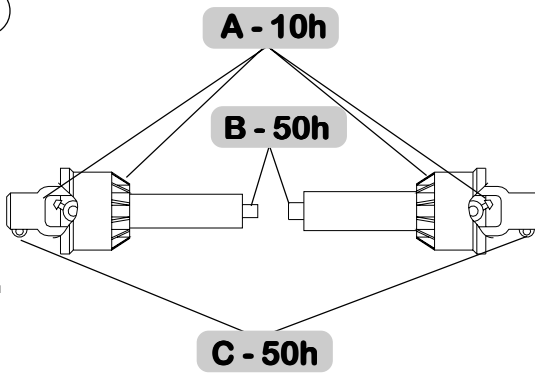

T226-0001

3

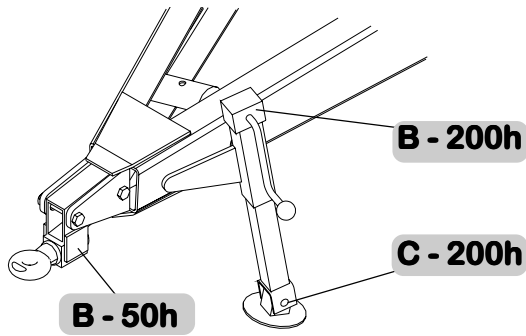

T202-0003

4

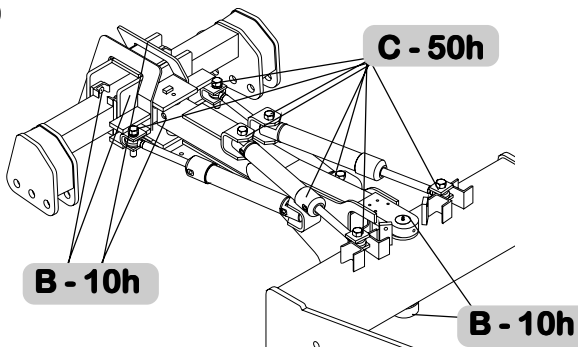

T202-0004

5

2200/2800

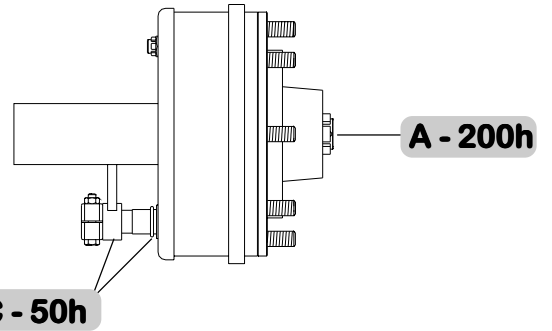

T202-0008

5

3200/4200

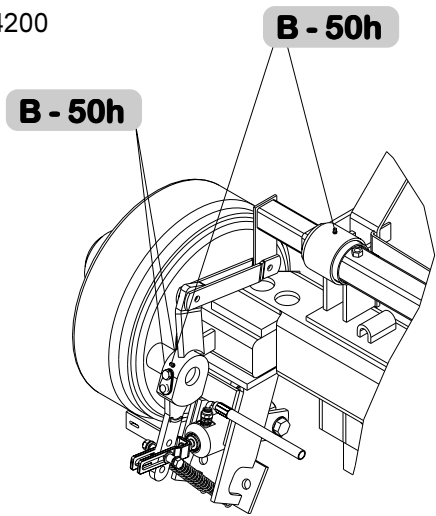

T202-0006

6

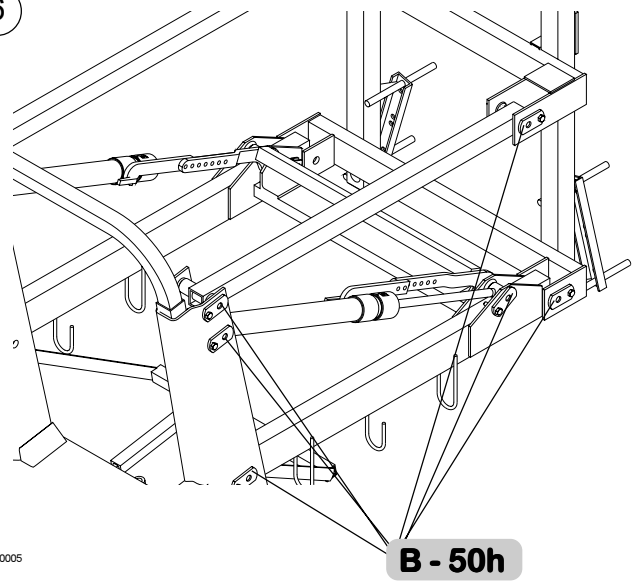

T202-0005

7

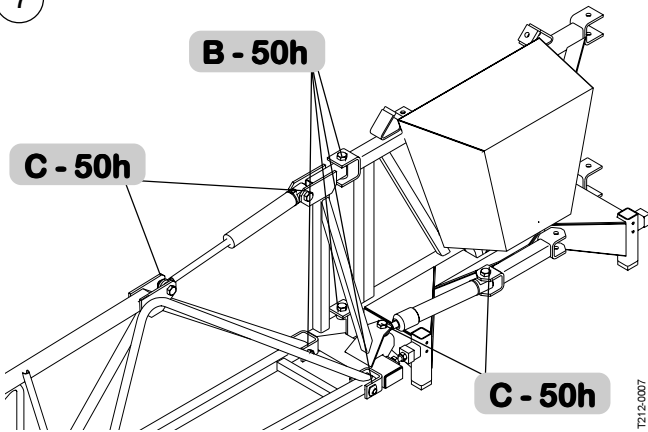

8

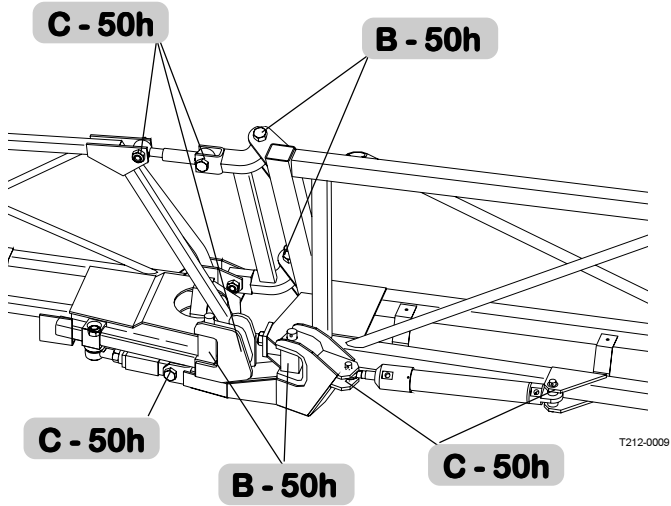

9

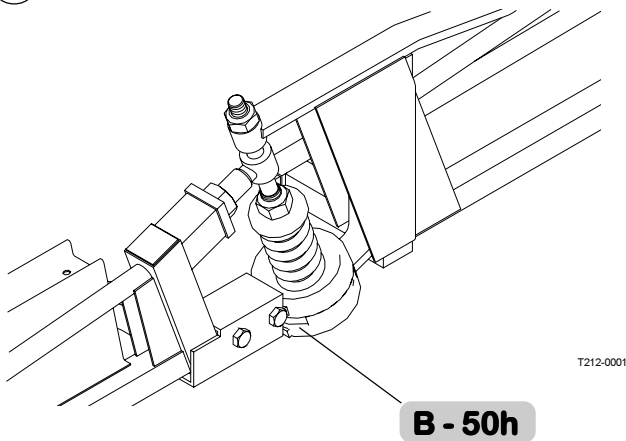

10

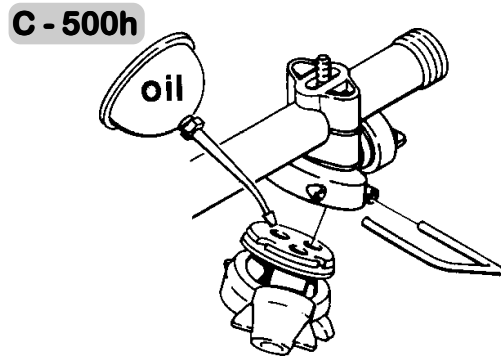

11

Only COMMANDER with Suspension

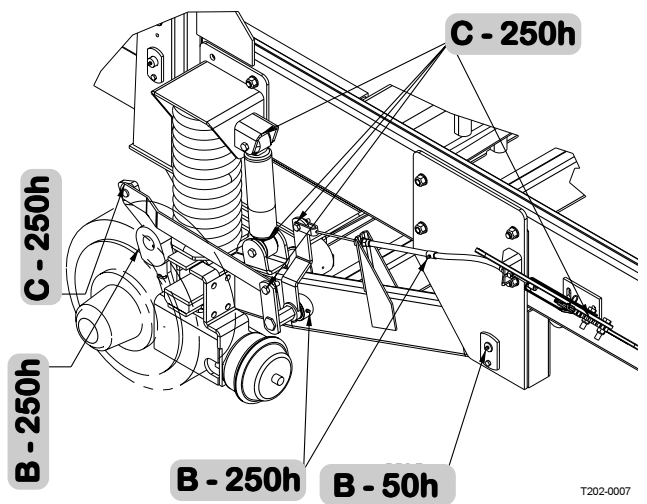



Service and Maintenance

10 hours service

1. Suction filter, clean
2. Self-cleaning filter, check and clean gauze if necessary
3. In-line filters, clean
4. Nozzle filters, clean
5. Spraying circuit, check for leaks
6. Brakes Air tank
7. Brakes
8. Retighten bolts (suspension only)

50 hours service

Do all previous mentioned +

1. Wheel bolts and nuts
2. Drawbar bolts
3. Air brakes
4. Expansion bottle (SELF TRACK only)
5. Tyre pressure
6. Transmission shaft

250 hours service

Do all previous mentioned +

1. Wheel bearings
2. Brake adjustment
3. Parking brake cables
4. Air brake filters
5. Hydraulic brakes
6. Hydraulic circuit
7. Expansion bottle (SELF TRACK only)
8. Safety valve (MULTI TRACK only)
9. Hoses and tubes
10. Brake adjustment (suspension only)
11. Readjustment of the boom

1000 hours service or yearly, whichever comes first

Do all previous mentioned +

1. Wheel bearings and brakes
2. Transmission shaft

Occasional maintenance

Pump valves and diaphragms renewal
Ball seat check/renewal, EC on/off valve
Cone check/renewal, EC distribution valve
Replacement of transmission shaft protection guards
Replacement of transmission shaft cross journals
Nozzle tubes and fittings
Level indicator adjustment
Cord renewal, level indicator
Seal renewal, drain valve
Wear bush renewal, boom lift and drawbar
Front articulating points
Priming the hydraulic system
TRACKER damper pressure setting
Shock absorbers



ALWAYS CHECK THAT ALL LOCK NUTS ARE TIGHT AFTER ADJUSTMENT!

10 hours service

1. Suction filter

To service the suction filter:

1. Pull the steel clip **A** out.
2. Lift the suction hose fitting **B** from housing.
3. Filter guide and filter **C** can now be removed.

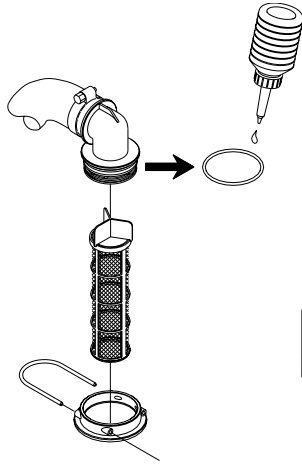

To reassemble:

4. Press the guide onto filter end.
5. Place the filter into housing with guide facing up.
6. Ensure the O-ring **D** on the hose fitting is in good condition and lubricated.
7. Refit the suction hose **B** and steel clip **A**.

2. Self-Cleaning Filter

1. Unscrew nut **A** and open filter.
2. Check filter gauze **B**, clean if necessary
3. Lubricate O-ring **C**
4. Assemble filter again.

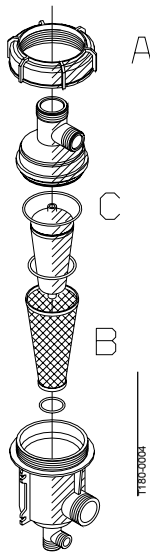

3. In-Line filter (if fitted)

If the boom is equipped with In-Line Filters unscrew the filter bowl to inspect and clean the filter.

Alternative filters are available. See section on Technical specifications - Filters and nozzles.

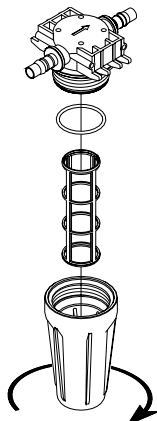

4. Nozzle filters

Check and clean.



T180-0006

5. Spraying circuit

Fill with clean water, operate all functions and check for leaks, use higher spray pressure than normal. Check nozzle spray patterns visually using clean water.

6. Brakes Air tank

Drain the air tank for condensed water at the drain valve.

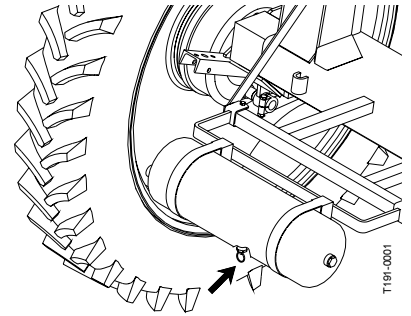

T181-0001

7. Brakes

Apply brake pedal and check function of trailer brakes.

8. Retighten bolts (suspension only)

Check that these 9 bolts - on each side of the COMMANDER - are tight. Retighten if necessary. Tightening torque: Bolt 1 = 24 Nm (retain nut on the backside of the mounting by a spanner while adjusting bolt 1).

Bolt 2-9: 280 Nm

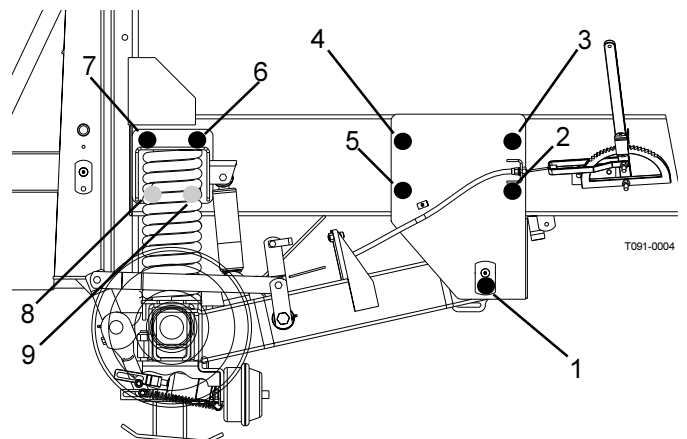

T091-0004

Bolt 8 and 9 are situated behind the spring.

50 hours service

1. Wheel bolts and nuts

Tighten wheel bolts and nuts as follows with following torque wrench settings:

Wheel hub to rim plate:
490 Nm (362 lbft)

Rim plate to rim:
280 + 30 Nm
(207 + 22 lbft)

Tightening sequence:
See illustration

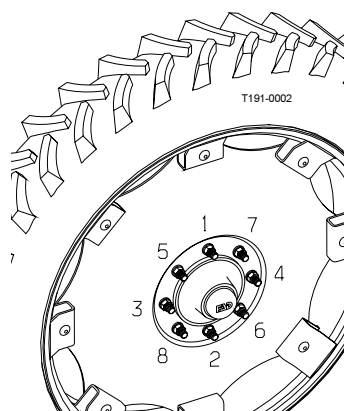

2. Draw bar bolts

The draw bar bolts must be tightened as follows:

1. Jack up the chassis so there is no load on the drawbar
2. Tighten the bolts **A** between tank frame and draw bar.
Torque wrench setting:
750 Nm (554 lbft)
3. Tighten bolts **B** at the towing eye.

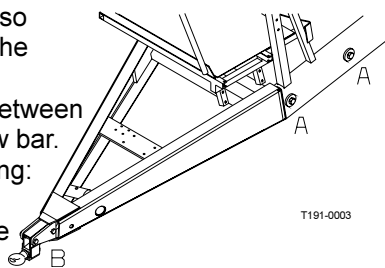

Torque wrench setting:
220 Nm (162 lbft)

3. Air brakes

The air brakes are checked for leaks by following procedure:

1. Connect the snap-couplers to the tractor and fill the trailer air tanks.
2. Check for leaks with brakes released.
3. Apply the brake up to full pressure.
4. Check for leaks with brakes applied.

4. Expansion bottle (SELF TRACK only)

Check air pressure in the expansion tank for the hydraulic damping at the pressure gauge.

Fill through valve **A**
if necessary.

Air pressure: 5 bar (73 p.s.i.)

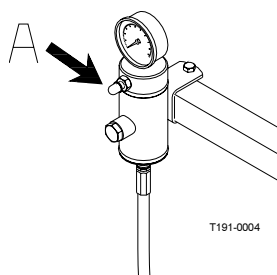

5. Tyre pressure

Check the tyre pressure according to the table below.

| Tyre size RC 95 | Recommended inflation pressure in bar (p.s.i.) | Minimum Load Index A8/A2 |
|---------------------------|--|--------------------------------|
| 230/95 R44 (9.5 x 44) | 3.6 (52) | 134/145 |
| 230/95 R48 (9.5 x 48) | 3.6 (52) | 136/147 |
| 270/95 R44 (11.2 x 44) | 3.6 (52) | 140/151 |
| 270/95 R48 (11.2 x 48) | 3.6 (52) | 142/153 |
| 12.4 x 46 | 3.6 (52) | 147/158 |
| 16.9 x 38 | 1.6 (23) | 141/152 |
| 18.4 x 38 | 1.6 (23) | 147/144 |
| 20.8 x 38 | 1.2 (18) | 154/151 |

chart 002

IMPORTANT! If renewing tyres always use tyres with min. load index as specified in the table.



WARNING! Never inflate tyres more than to the pressure specified in the table. Over-inflated tyres can explode and cause severe personal injuries! See paragraph "Tyre safety".

6. Transmission shaft

Check function and condition of the transmission shafts protection guards. Replace possible damaged parts

250 hours service

1. Wheel bearings

Check for play in the wheel bearings:

1. Place stop wedges in front of and behind LH wheel and jack up RH wheel
2. Rock the RH wheel to discover possible play in the bearings.
3. If any play, support the wheel axle to prevent trailer from falling down from the jack.
4. Remove hub cap **A** and cotter pin **B**. Turn the wheel and tighten the castellated nut **C** until a slight resistance in the wheel rotation is felt.
5. Loosen the castellated nut until the first notch - horizontal or vertical - is aligned with the cotter pin hole in the shaft.
6. Fit a new cotter pin and bend it.
7. Fill the hub cap with fresh grease and press it on to the hub again.
8. Repeat the procedure on LH wheel.

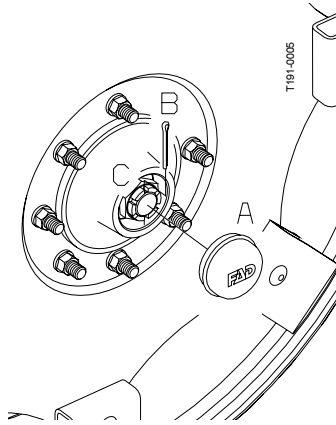

2. Brake adjustments

The parking brake is adjusted the following way:

2200/2800:

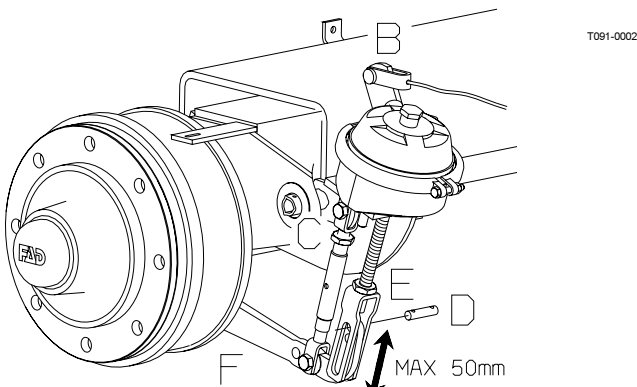

1. Place stop wedges in front of and behind the LH wheel and lift the RH wheel from the ground.
2. Loosen the handbrake adjusting mechanism **A** allowing the arm **B** to rest against the axle.
3. Loosen the counter nut **C** and shorten the rigging screw until the brake is locked.
4. Loosen the rigging screw again until the wheel is just

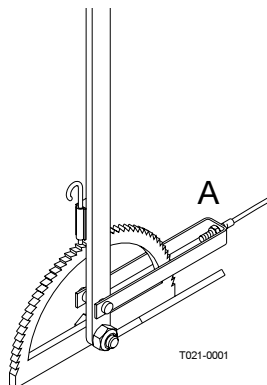

5. turning freely again and tighten the counter nut again.
5. Repeat on LH wheel.
6. The handbrake adjusting mechanism must be shortened until the activating arm **B** starts to move when the 2nd ratchet on the hand brake lever mechanism is reached.
7. If either hydraulic or air brakes is fitted, the stroke of the rams or brake chamber rods must be adjusted subsequently.
8. If the stroke of the air brake chamber rod or hydraulic ram rod are exceeding 50 mm (2.0 in) the brakes must be adjusted.
9. Remove the clevis pin **D** and adjust by turning the clevis **E**.
Fit clevis pin again and secure with cotterpin.
- NOTE!** If the stroke cannot be adjusted to max. 25 mm (1.0 in) the lever **F** must be repositioned on the splines of the actuating shaft. This requires full readjustment of the parking brake again.
10. Check that the two rods are travelling the same length from disengaged to engaged position. If not, adjust again.
11. Make a brake test on a hard, even surface to see if both wheels are braking equally. If not, fine adjust till even braking is obtained.

3200/4200:

Wheel brake

The wheel brake is adjusted the following way:

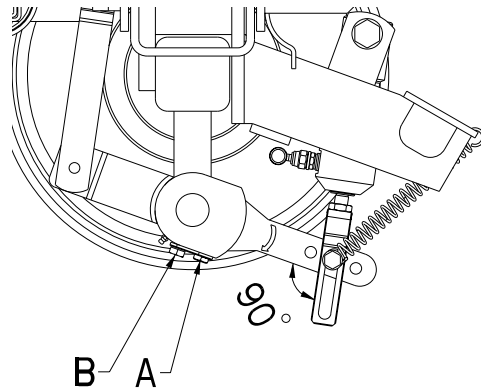

1. Place stop wedges in front of and behind the LH wheel and lift the RH wheel from the ground.
2. Loosen the handbrake.
3. The wheel must turn freely - make a test!
4. Activate the wheel brakes.
5. Control the angle on the brake activation arm and the fork bolt. If this angle exceeds 90°, adjustments are required as described in 5a-5c.
- 5a. Relieve the wheel brakes.
- 5b. Loosen nut **B**, lift and flip the lock plate aside and adjust the angle of the brake activation arm by nut **A**.
- 5c. Activate the wheel brakes again and control whether the angle is < 90°. If not, repeat 5a-5c.
6. Repeat this procedure at the opposite wheel.

Parking brake

Inspect the following:

The parking brake lever:
If it can be pulled further backwards than 90° (midway), using a traction of approximate 25 kg., the cable needs to be shortened.

The parking brake cable:
When the parking brake is relieved, the cable must be limp; otherwise it needs to be lengthened.

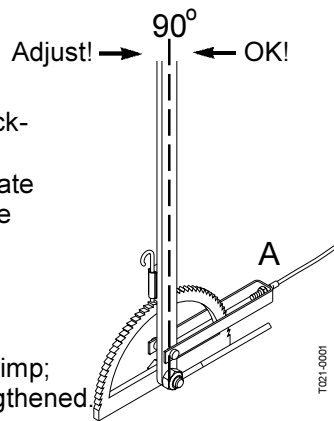

Correct length: When the brake is relieved the cable must be tight and yet not stretched.

Lengthening/shortening of the parking brake cable is carried out by adjusting the nut **A**.

3. Parking brake cables

Inspect the parking brake cables for possible wear or damages. Replace worn or damaged parts.

4. Air brake filters (if fitted)

1. Clean the area around air filter(s) and disconnect air hose from the tractor.
2. Hold one hand under the filter housing, and pull out the retainer clip **A**. The filter cartridge assembly will be pushed out by the springs inside the filter housing.
3. Clean the filter cartridge. Use water and an appropriate detergent or compressed air.
4. Dry the parts and reinstall in the order shown. The O-ring should be lightly lubricated with silicone grease before installation.

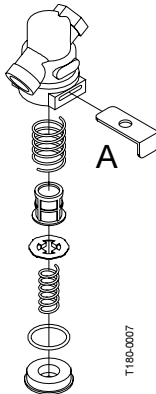

5. Hydraulic brakes

Apply brakes to full pressure and inspect brake lines for damages or leaks. Replace damaged parts.

IMPORTANT! If the hydraulic brake lines have been dismantled the circuit must be primed afterwards:

1. Loosen brake hose at both brake cylinders.
2. Apply brake until oil without air bubbles come out.
3. Tighten brake hose before relieving the brake again.

6. Hydraulic circuit

Check the hydraulic circuit for leaks and repair if any.

7. Expansion bottle (SELF TRACK only)

Check the oil level:

1. Depressurize the expansion bottle through valve **A** first.
2. Remove the level plug **B** and check that the oil level is reaching the level hole. Add if the level is low.
3. Tighten the plug again and inflate the bottle to 5 bar air pressure.

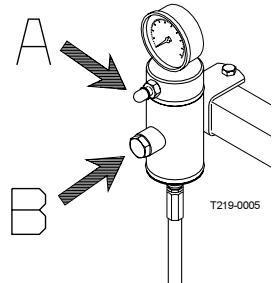

8. Safety valve (MULTI TRACK only)

The safety valve must open to allow the yoke to turn if the rear hydraulic rams are fully extended/retracted. The clearance between valve and activating mechanism must be checked and adjusted if necessary.

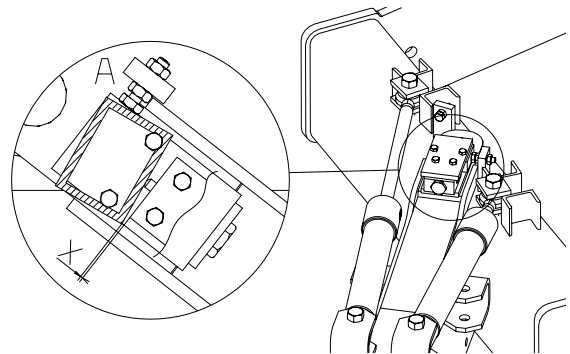

1. Articulate the drawbar fully to one side.
2. Check the clearance **X** with a feeler gauge, adjust the screw **A** till the clearance is 2 mm ± 0.1 mm (0.0787 in ± 0.00039 in). Tighten the counter nut.
3. Articulate the drawbar fully to the other side and repeat point 2.

9. Hoses and tubes

Check all hoses and tubes for possible damages and proper attachment. Renew damaged hoses or tubes.

10. Brake adjustment (suspension only)

1. Lift the back of the COMMANDER from the ground. It is recommended to use two lifting jacks, placed underneath the axle. Make sure the COMMANDER is stable and secured before carrying out any adjustments.
2. Place the handbrake in the first jag from the left (please refer to illustration).

NOTE! The following adjustment must be carried out simultaneously on both brakes. Therefore, alternately adjust on both LH brake and RH brake.

3. Loosen nut B, lift and flip the small lock plate aside.
4. Adjust the nut A clockwise
Turn the nut 90° (1/4 turn)
at a time - alternately on both
LH and RH
brake.

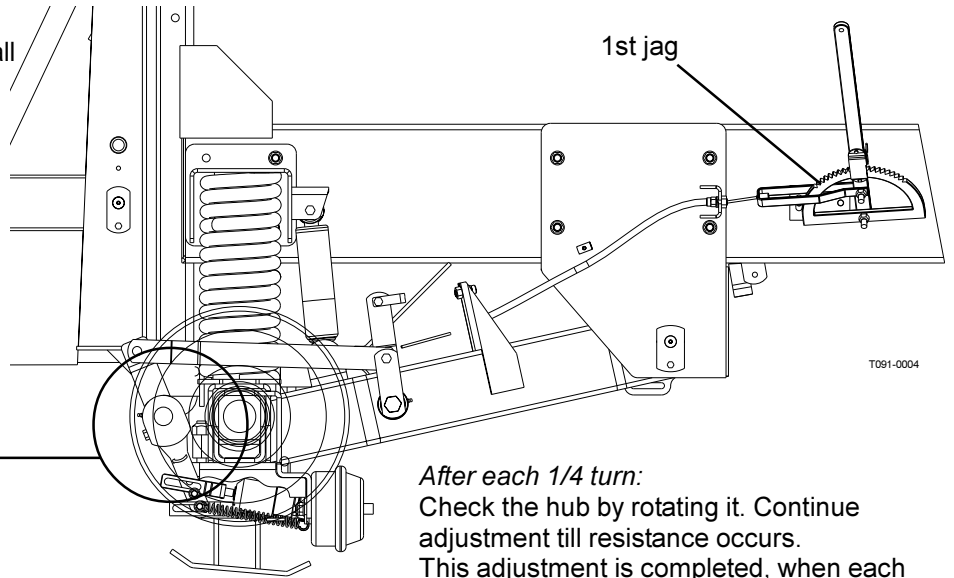

T101-0040

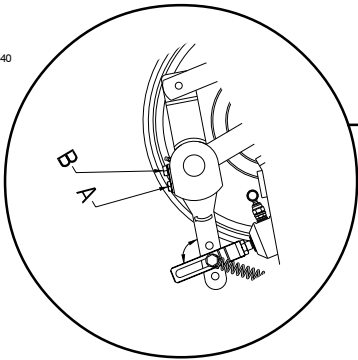

After each 1/4 turn:
Check the hub by rotating it. Continue
adjustment till resistance occurs.
This adjustment is completed, when each
hub is strained.

Readjustment of the boom

After having used the sprayer for some days the boom should be adjusted according to the following instructions.

Before adjusting the boom, please go through this check list:

- The sprayer must be lubricated (Please see part about Lubrication)
- Tractor and sprayer must be placed on level ground
- The boom must be unfolded
- Set slanting angle at midway

Adjustment of hydraulic cylinders is done without pressure in the hydraulic system.



WARNING! NOBODY IS ALLOWED UNDER THE BOOM WHILST ADJUSTMENT IS CARRIED OUT.

Transport position and boom alignment (OLS)

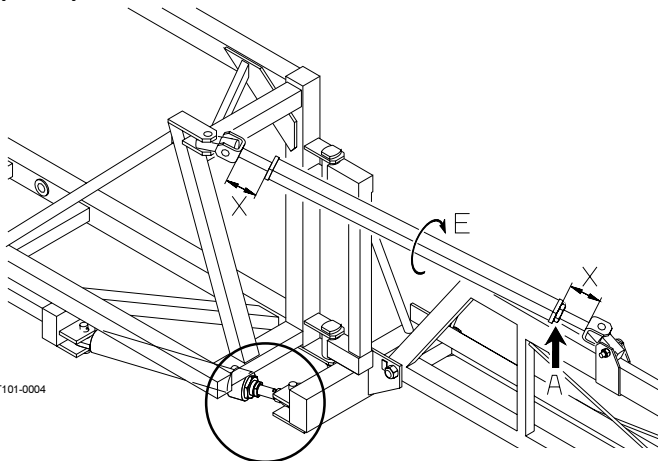

T101-0004

1. Fold the boom until the folding rams are fully extended. Check that the boom wings are right above the transport brackets. Adjust on **F** if the wings is not positioned correctly.
2. Lower the boom lift until the boom rest on the front and the rear transport brackets. If not, adjust on **E** until the boom rest on the front and rear transport brackets. Tighten counter nuts again.

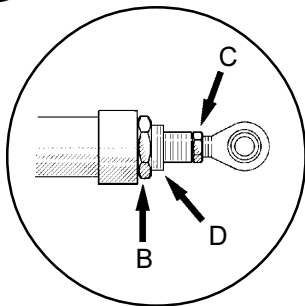

cylinderjater-3(L)

IMPORTANT! The length of the clevis bolt must not exceed 90 mm!

3. Unfold the boom completely.

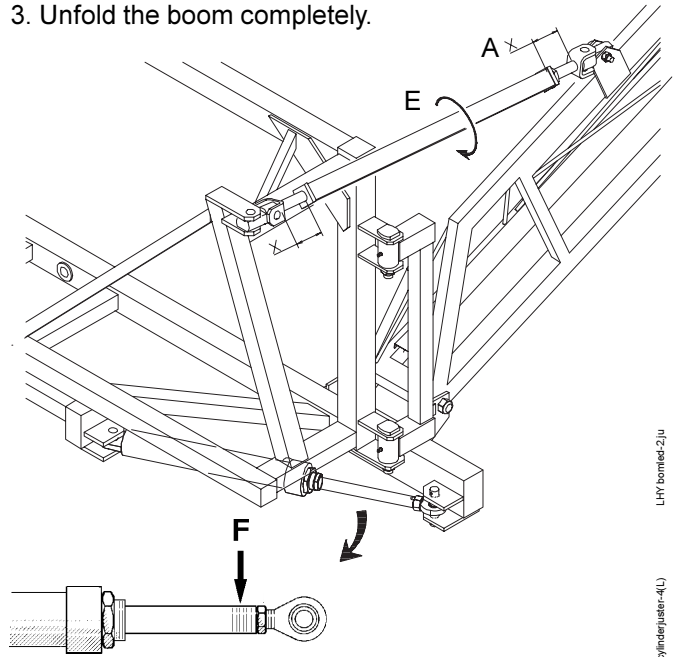

LH7boomled-2ju

cylinderjater-4(L)

4. Check that the boom is horizontal. If not, loosen the counter nut **B** and adjust the bush **D** until the boom appears horizontally and vertically aligned. The boom may point a little forward. Tighten all counter nuts.

The following adjustments are best done without pressure in the hydraulic rams.

Linear adjustment of outer section (OLS)

To adjust, loosen lock nut **A** and turn cylinder rod.

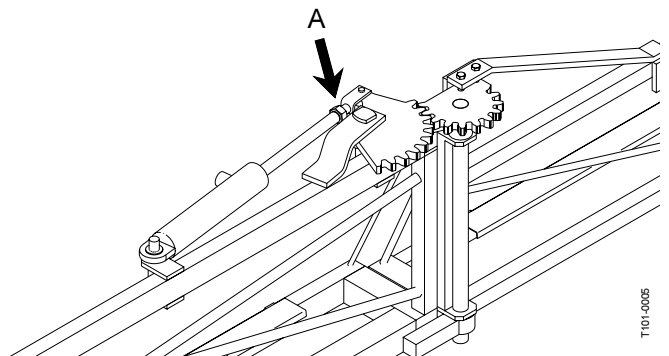

T101-0005

End stop valve adjustment (28 m OLS only)

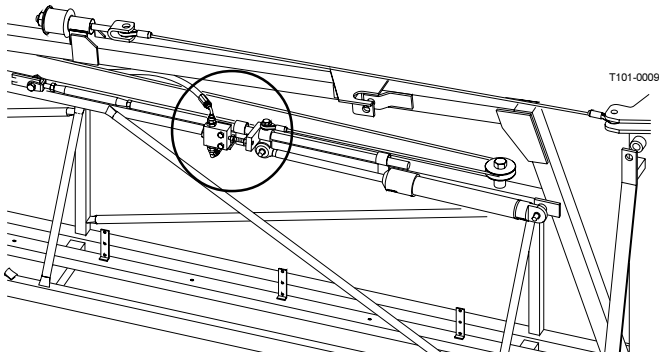

Intermediate/outer sections are unfolded simultaneously. When folding the boom it is very important that the outer section are folded before the intermediate sections. Adjustment is done by means of screw **A** until a distance of 5 mm (0.197 in) is reached. Tighten counter nut **B**.

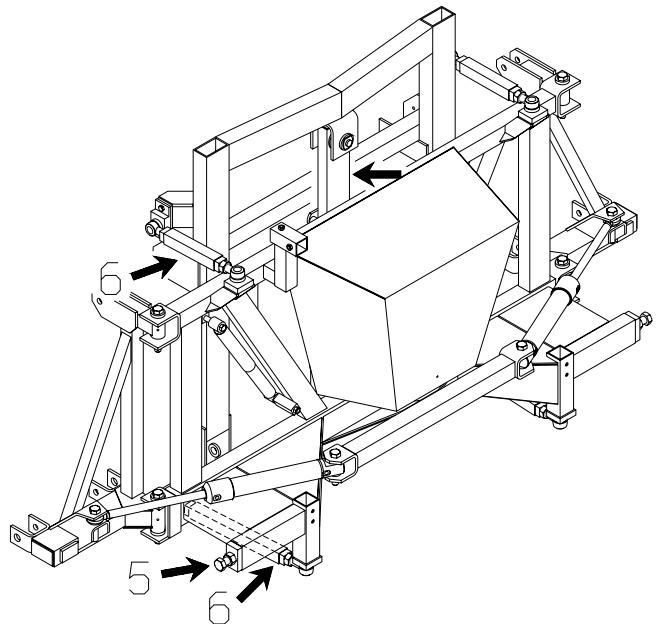
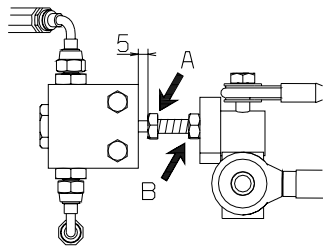

Adjustment of pendulum suspension (OLH/OLV/OLS)

Boom must be unfolded to working position. Remove the 4 stabilising rods **6** by detaching the ball joints.

When the boom is hanging free, adjust the length of the stabilising rods and attach the ball joints again.

Adjustment of outer section folding (OLH/OLV)

Unfold the outer sections completely and remove bolt **E** of the ball joint rod.

Adjust inner/outer section alignment at adjustment screws **I** and **J**.

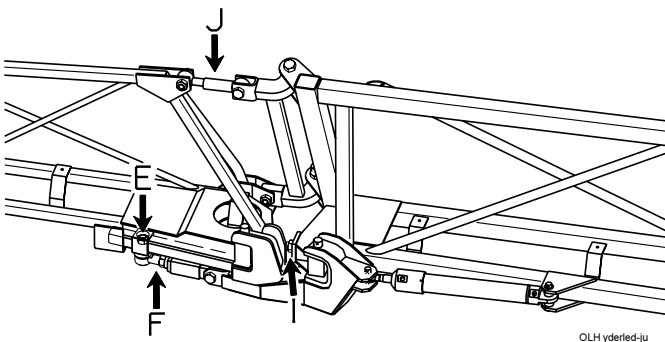

Adjust length of ball joint rod **F**, until bolt **E** fits - assemble the locking device again.

Adjustment of inner section folding (OLH/OLV/OLS)

Boom must be unfolded to working position, Adjust inner section/centre section alignment at adjustment screw **5**.

Breakaway (OLH/OLV/OLS)

The function of the breakaway is to prevent or reduce boom damage, should it strike an object or the ground. The breakaway cannot be adjusted, but should only be kept greased.



CHECK THAT ALL LOCK NUTS ARE TIGHT AFTER PERFORMING THE ADJUSTMENTS.

1000 hours service

1. Wheel bearings and brakes

Check the condition of the bearings and brake wear parts the following way:

1. Place stop wedges in front of and behind LH wheel and jack up RH wheel.
2. Support the trailer with axle stands.
3. Remove the wheel.
4. Remove the hub cap **A**, cotter pin **B** and castle nut **C**.
5. Pull off the wheel hub and brake drum assembly. Use a wheel puller if necessary.
6. Vacuum clean the brake drum **D** for brake dust or rinse with water.

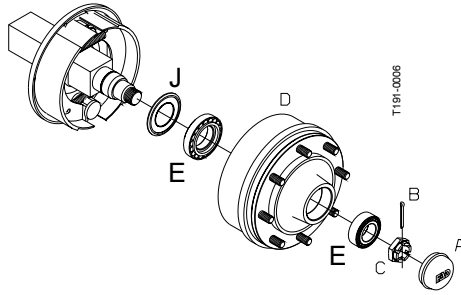

WARNING! Brake dust can cause severe health injuries! Avoid inhalation of brake dust! Use respirator when servicing the brakes. Do not clean brakes with compressed air! Use vacuum cleaner or rinse with water to avoid brake dust being blown around.

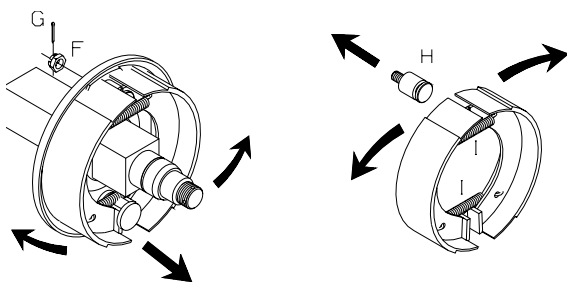

7. Rinse the remaining parts on the brake carrier plate with water and dry them.
8. Remove roller bearings **E**, clean all parts in degreasing detergent and dry them.
9. Check the brake drum diameter and lining thickness - renew if worn.

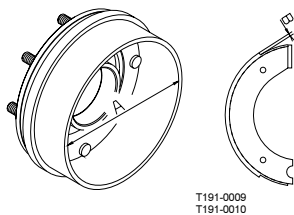

| Max. wear rates on brake components, mm (in) | | |
|--|---------------|---------------|
| Model | 2200/2800 | 3200/4200 |
| Max. drum diameter A | 302 (11.8897) | 402 (15.8388) |
| Min. lining thickness B | 2.0 (0.07874) | 4.0 (0.15748) |

IMPORTANT! The specified min. thickness is the absolute minimum which must never be exceeded. Renew the parts if they would reach the above dimensions before next service inspection.

IMPORTANT! Renewal of brake linings or brake drums must be done both sides at the same time.

NOTE! If the brake drum must be removed from the hub, a hydraulic press is required to press the wheel studs out.

10. Remove the clevis pin between the air diaphragm cylinder and brake cam lever.
11. Remove the cotterpin **G** and nut **F**, the brake shoe anchor bolt **H** and slide the brake shoes over the cam. Twist the pair of brake shoes to remove the shoe return springs **I**. Replace brake shoes if the linings are worn.
12. Apply a small qty. of copper paste on moving parts and assemble the brake shoes and shoe return springs again.



WARNING! Do not get oil, grease or copper paste in contact with the brake linings and drums.

13. Fit the shoe assembly with the anchor bolt first. Then pull the shoes away from each other and slide them over the cam afterwards. Tighten the anchor bolt castellated nut again and fit a new cotter pin.
14. Check roller bearings for discoloration and wear - renew if worn or damaged.
15. Assemble the hub and bearings using a new sealing ring **J**.
16. Fill the hub and bearings with fresh grease before fitting it to the shaft.
17. Fit the castellated nut. Rotate the hub and tighten the castellated nut until a slight rotation resistance is felt.
18. Loosen the castellated nut again until the first notch is aligned with the cotter pin hole in the shaft.

NOTE! The shaft has a vertical and an horizontal cotter pin hole. Use the one first aligned with the notch when loosening the castellated nut.

19. Fit a new cotter pin and bend it.
20. Fill the hub cap with fresh grease and carefully press it on to the hub.
21. Adjust the brakes as described in "200 hours service".
22. Fit the wheel again and tighten the wheel nuts. See section "50 hours service" regarding torque wrench setting. Tighten all bolts to half the specified torque first, then to the full specified torque.
23. Tighten again after 10 hours of work. Check the torque every day until it is stabilised.



WARNING! If you do not feel totally confident changing wheel bearings or brake shoes contact your HARDI dealers workshop.

2. Transmission shaft

Change the protection tube nylon bearings as described under "Replacement of transmission shaft protection tubes".

Occasional maintenance

The maintenance and renewal intervals for the next points will depend very much on the conditions under which the sprayer will operate, and are therefore impossible to specify.

Pump valves and diaphragms renewal

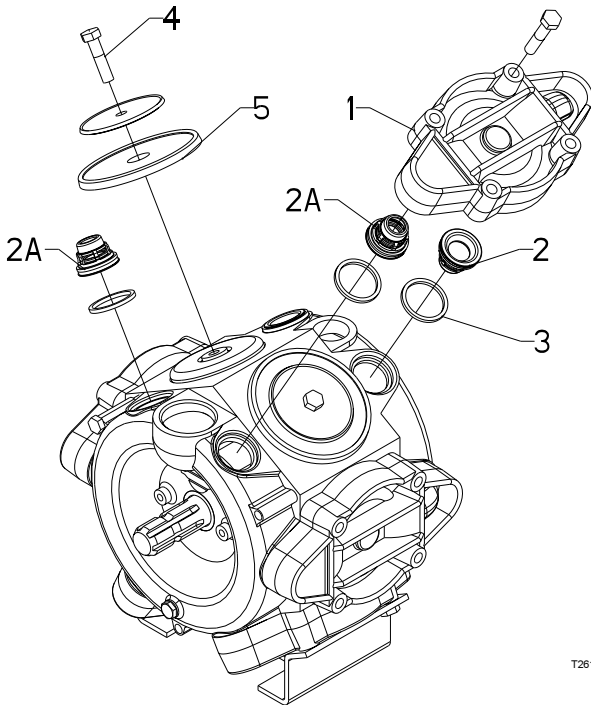

T261-0001

Diaphragm pump overhaul kit (valves, seals, diaphragms etc.)

| Pump model | HARDI part No. |
|------------|----------------|
| 363 | 750342 |
| 463 | 750343 |

Valves

Remove valve cover **1**. Before changing the valves **2** note their orientation so they are replaced correctly. **NOTE:** One special valve with white flap **2A** is used. It has to be placed in the valve opening shown. It is recommended to use new gaskets **3** when changing or checking the valves.

Diaphragms

Remove the diaphragm cover **4**. The diaphragm **5** may then be changed. If fluids have reached the crankcase, re-grease the pump thoroughly. Check also the drain hole at the bottom of the pump is not blocked. Reassemble with the following torque setting.

| Pump model | Diaphragm cover Nm | Diaphragm bolt Nm |
|------------|--------------------|-------------------|
| 363 | 90 | 90 |
| 463 | 90 | 90 |

1 Nm = 0.74 lbft

Ball seat check/renewal, EC on/off valve

If the main ON/OFF valve does not seal properly (dripping nozzles when main ON/OFF valve is closed), the ball and seat should be checked.

Remove the 2 bolts fixing the main ON/OFF-pressure valve unit to the bracket, unscrew the union nut **A** and pull the valve away from the distribution valves.

Check the ball for sharp edges and scratches, and check the ball seat for cracks and wear - replace if necessary.

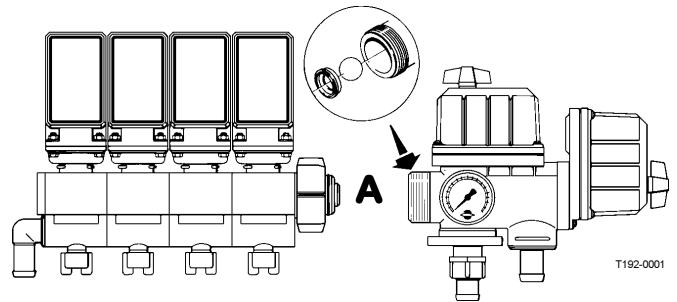

T192-0001

Cone check/renewal, EC distribution valve

Periodically check the distribution valves for proper sealing. Do this by running the sprayer with clean water and open on/off valve and all distribution valves.

Cautiously remove the clip **A** and pull out the hose **B** for the pressure equalisation device. When the housing is drained, there should be no liquid flow through the pressure equalisation device. If there is any leakage, the valve cone **E** must be changed.

Remove the clip **C** and lift the EC-motor housing off the valve housing. Then unscrew the screw **D** and replace the valve cone **E**. Reassemble in reverse order.

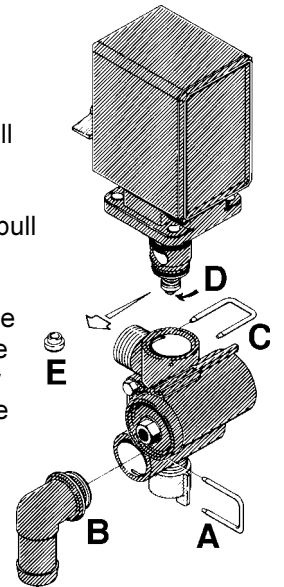

Wear bush renewal, boom lift

The wear bushes are inspected and renewed before they are worn through.

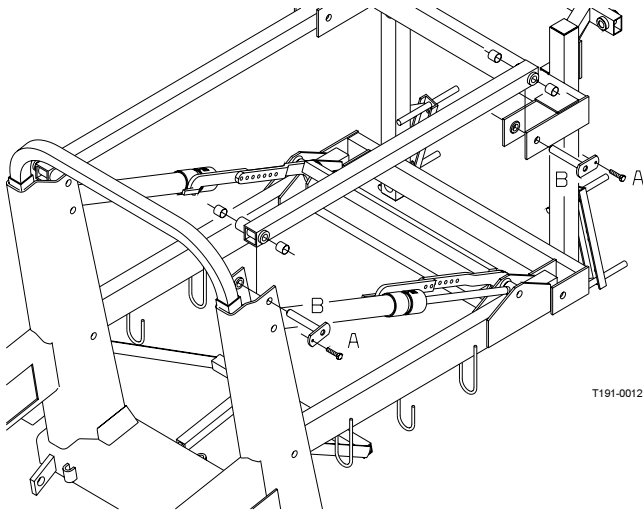

T191-0012

1. Connect the trailer to a tractor and unfold the booms to working position.
2. Lift the boom centre frame with a lifting device and support it until the load is taken off the parallelogram arms.
3. Remove the screws **A**, and pull out the pins **B** at one of the upper parallelogram arms and renew the wear bushes.
4. Refit the arm.
5. Repeat this on the other upper arm.
6. The lower arms must be disconnected simultaneously.
Grease all grease nipples.
7. Remove the lifting gear again.

Wear bush renewal, drawbar (TRACKER models only)

If too much play in the drawbar is found the wear bushes must be renewed.

Main articulating point
(all TRACKER models)

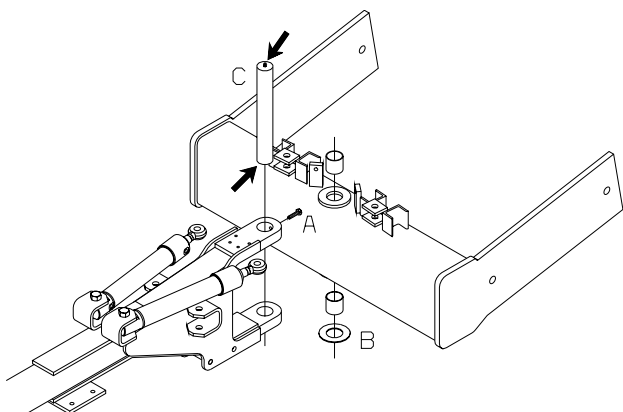

T262-0005

1. Place stop wedges in front of and behind both wheels.
2. Jack up the frame and support it properly.
3. Without dismantling the hydraulic system the rear hydraulic rams are removed from the drawbar.
4. Support the drawbar and remove the screw **A**, washer **B** and the pin **C**.
5. Move the drawbar sideways and support it.
6. Press out the worn bushes and fit new ones.
7. Assemble again in reverse order.
8. Grease through grease nipples and remove jack and wedges.
9. Place the sprayer on the support leg

Front articulating points (SELF and MULTI TRACK only)

1. Disconnect the sprayer from the tractor.
2. Without dismantling the hydraulic system remove the front rods or hydraulic rams from the cardan joint.
3. Dismantle by removing the bolts **A** and **B** and press out the bushes **C**.
4. Fit new bushes. Ensure that the bushes are situated at each end of the pin hole.
5. Replace the wear pads **D** if worn. Max. clearance between wear pads and yoke is 1 mm (0.03937 in). Check with feeler gauge and add 1 mm shims if clearance is over 1 mm.
6. Assemble in reverse order.
7. Grease through grease nipples.
8. On SELF TRACK the support rods must be extended as much as possible so they are pressing against the yoke.

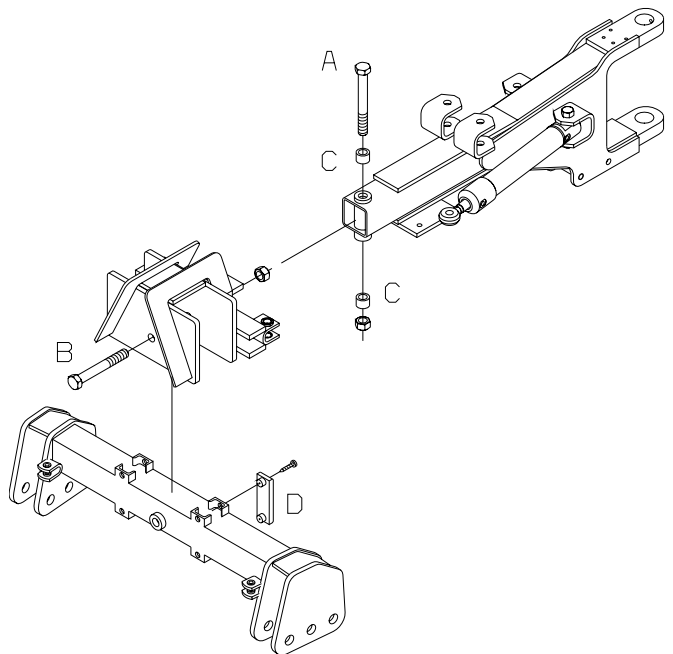

Priming the hydraulic damping system (TRACKER only)

If the hydraulic damping system has been dismantled the system needs to be refilled and primed again.

SELF TRACK

1. Depressurize the expansion bottle, remove the hydraulic hose and connect it to an oil pump.
2. Disconnect the hydraulic ram piston rods and loosen the hose fittings at each ram. Retain waste oil in an appropriate container.
3. Retract both rams fully to remove all air from the rams.
4. With the rams fully retracted, pump clean oil through the hydraulic system until all air is out.
5. Tighten the hose fittings again.
6. Pump oil till the rams extend again. Connect the piston rods again.
7. Disconnect the hose from the pump and connect it to the expansion bottle again.
8. Fill with clean oil until it reaches the level hole again. Fit the plug.
9. Inflate the expansion tank to 5 bar (78 p.s.i.) and fit the dust cap again.
10. When the TRACKER is connected to the tractor the hydraulic ram piston rods are allowed to move max. 5 mm (0.19685 in) when the sprayer is pushed hard by hand from side to side. If more than 5 mm repeat the priming procedure again.

MULTI TRACK

1. The sprayer shall be disconnected from the tractor except for the hydraulics and D.A.H. control box.
2. Loosen the hydraulic hose connections on all rams and retract all hydraulic rams fully. Retain waste oil in an appropriate container.

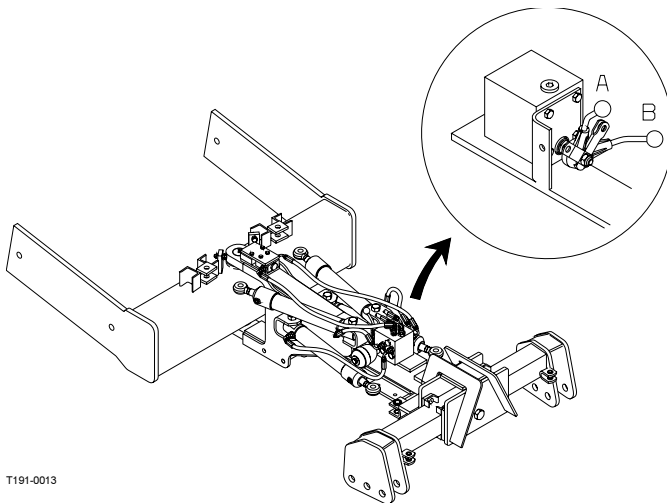

3. The lever on the hydraulic valve block is set vertical (pos. **A**).
4. Start the tractor and activate the track correction switch on the D.A.H. control box until oil free from air is streaming out of the hoses.
5. When all air is out the hose fittings are retightened.

Activate again, and let the oil pressure extend the rams until they reach the drawbar again. Then fit bolts again.

6. Set the lever in horizontal pos. **B**.
7. Activate the track correction switch until oil free from air is streaming out.
8. Tighten the hose fittings again, and let the oil pressure extend the rams till they reach the yoke again. Fit the bolts.
9. When the damping system is primed the rams must not be able to move more than 1 mm (0.03937 in) when the trailer is pushed hard from side to side by hand.
10. If the rams are moving more than 1 mm the priming procedure is repeated.

TRACKER damping pressure setting

The hydraulic pressure relief valves in the TRACKER's damping system is factory set to open at appr. 40 bar (580 p.s.i.) which is adequate for most conditions.

If the damping seems too "soft" or too "hard", the settings can be adjusted on the screws shown.

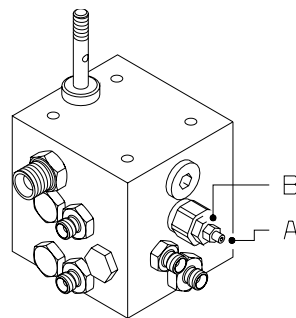
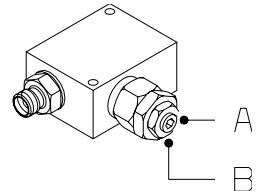

Connect pressure gauges to the minimesh gauge connectors and check that pressure setting is equal to both sides.

A = adjustment
B = counter nut

NOTE! Too low setting will cause instability of the sprayer, and too high pressure setting will cause problems with the tractor steering.

Shock absorbers

If the shock absorbers loose their efficiency or start leaking oil, they should be replaced.

Level indicator adjustment

The level indicator reading should be checked regularly.

When the tank is empty, the float should lie on the stop pin, of the rod, and the O-ring on the indicator should be positioned at the top position line **A**.

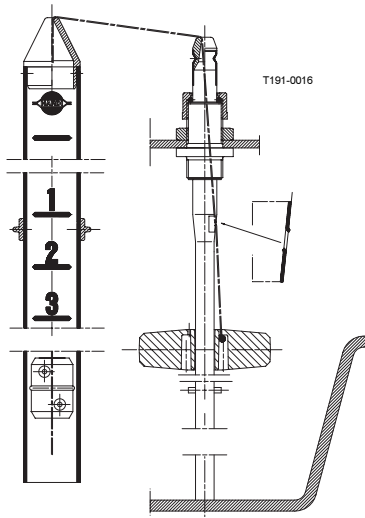

If any deviation is found, pull out the plug **B**, loosen screws **C**, and adjust the length of the cord.

Cord renewal, level indicator

If the cord on the level indicator has to be changed, the float guide pole is removed:

1. Remove the tank drain valve (see paragraph "Main tank drain valve") and loosen the fitting holding the pole in position.
2. Pull the pole down through the drain valve hole till it is free in the top of the tank.
3. The pole can now be taken out of the tank through the filling hole.



DANGER! Do not attempt to enter the tank - the float pole can be removed from outside the tank!

Seal renewal, drain valve

If the main tank drain valve leaks, the seal and seat can be changed the following way.



DANGER! Do not enter the inside of the tank - the parts can be changed from underneath the tank!



WARNING! Use eye / face protection mask when dismantling the tank drain valve!

1. Make sure the tank is empty and clean.
2. The valve must be closed and the string loose.
3. Pull out the clip **A** and pull down connecting piece **B**. The entire valve assembly can now be pulled out.
4. Check cord and valve flap assembly **C** for wear, replace seal **D** and assemble again.
5. Assemble the valve assembly again using a new valve seat **E**. Lubricate O-rings **F** before assembly.
6. Fit clip **A** again.

NOTE! Check function of valve with clean water before filling chemicals into the tank.

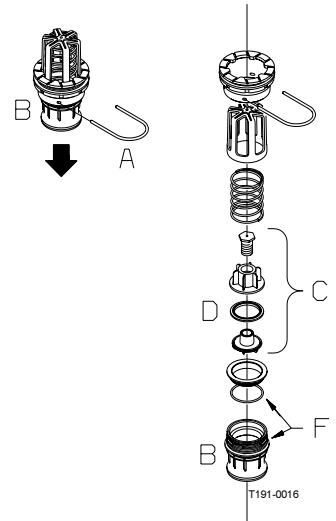

Nozzle tubes and fittings

Poor seals are usually caused by:

- missing O-rings or gaskets
- damaged or incorrectly seated O-rings
- dry or deformed O-rings or gaskets
- foreign bodies

In case of leaks:

DO NOT overtighten. Disassemble, check condition and position of O-ring or gasket. Clean, lubricate and reassemble.

The O-ring must be lubricated **ALL THE WAY ROUND** before fitting on to the nozzle tube. Use non-mineral lubricant.

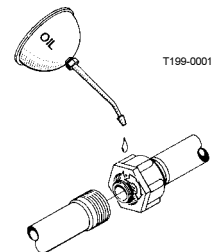

For **RADIAL** connections only hand-tighten them.

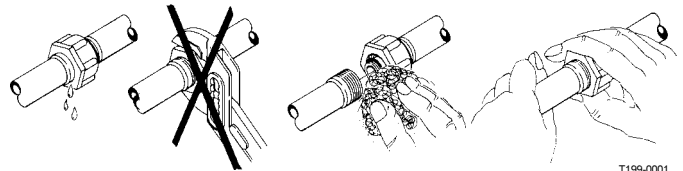

For **AXIAL** connections, a little mechanical leverage may be used.

Replacement of transmission shaft protection guards

1. Remove bolt **A**, lock **B** and grease nipple **C**. Twist uni CV-joint cover 1/4 turn and pull it backwards.

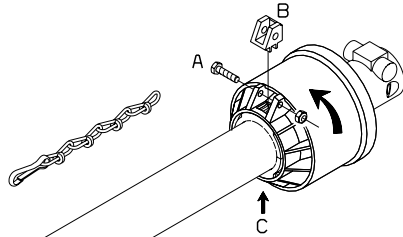

2. Remove the synthetic bearings and protection tube.

2a. Remove inner bush from protection tube.

3. Assemble again in reverse order, using new parts where necessary. Remember to fit chains again.

4. Grease bearings.

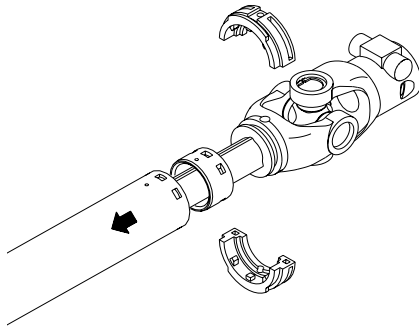

NOTE! Only use genuine HARDI spare parts to service the transmission shaft.

Replacement of transmission shaft cross journals.

1. Remove protection guard as described previously.

2. Remove Seeger circlip rings

3. Press the cross journal sideways - use hammer and mandrel if necessary.

4. Remove needle bearing cups and cross journal can now be removed.

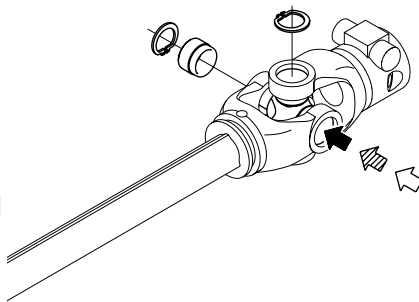

5. Carefully remove needle bearing cups from new cross journal and install it in reverse order.

Before fitting the needle bearing cups again, check that needles is placed correctly. Avoid dust and dirt in the new bearings.

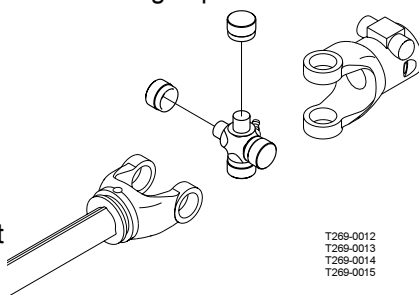

T269-0012
T269-0013
T269-0014
T269-0015

Off-season storage

When the spraying season is over, you should devote some extra time to the sprayer.

If chemical residue are left over in the sprayer for longer periods, it can reduce the life of the individual components.

To preserve the sprayer intact and protect the components, carry out following off-season storage program.

1. Clean the sprayer completely - inside and outside - as described under "Cleaning of the sprayer". Make sure that all valves, hoses and auxiliary equipment has been cleaned with detergent and flushed with clean water afterwards, so no chemical residue is left in the sprayer.
2. Renew possible damaged seals and repair possible leaks.
3. Empty the sprayer completely and let the pump work for a few minutes. Operate all valves and handles to drain as much water off the spraying circuit as possible. Let the pump run until air is coming out of all nozzles. Remember to drain the rinsing tank also.
4. Pour appr. 50 litre (11 Imp.gal) anti-freeze mixture consisting of 1/3 automotive anti-freeze and 2/3 water into the tank.
5. Engage the pump and operate all valves and functions on the MANIFOLD, operating unit, FILLER etc. allowing the anti-freeze mixture to be distributed around the entire circuit. Open the operating unit main on/off valve and distribution valves so the anti-freeze is sprayed through the nozzles as well.
The anti-freeze will also prevent O-rings, seals, diaphragms etc. from drying out.
6. Lubricate all lubricating points according to the lubricating scheme regardless of intervals stated.
7. When the sprayer is dry remove rust from possible scratches or damages in the paint and touch up the paint.
8. Remove the glycerine-filled pressure gauges and store them frost free in vertical position.
9. Apply a thin layer of anti-corrosion oil (e.g. SHELL ENSIS FLUID, CASTROL RUSTILLO or similar) on all metal parts. Avoid oil on rubber parts, hoses and tyres.
10. Fold the boom in transport position and relieve pressure from all hydraulic functions.
11. All electric plugs and sockets are to be stored in a dry plastic bag to protect them against damp, dirt and corrosion.
12. Remove the control boxes and the HARDI PILOT control box + display from the tractor, and store them dry and clean (in-house).
13. Wipe hydraulic snap-couplers clean and fit the dust caps.
14. Apply grease on all hydraulic ram piston rods which are not fully retracted in the barrel to protect against corrosion.

15. Chock up the wheels, to prevent moisture damage and deformation of the tyres. Tyre blacking can be applied to the tyre walls to preserve the rubber.
16. Drain air brake tank for condensed water.
17. To protect against dust the sprayer can be covered by a tarpaulin. Ensure ventilation to prevent condensation.

Preparation after off-season storage

After a storage period the sprayer should be prepared for the next season the following way:

1. Remove the cover
2. Remove the support from the wheel axle and adjust the tyre pressure.
3. Wipe off the grease from hydraulic ram piston rods.
4. Fit the pressure gauges again. Seal with Teflon tape.
5. Connect the sprayer to the tractor including hydraulics and electric's.
6. Check all hydraulic and electric functions.
7. Empty the tank for remaining anti-freeze.
8. Rinse the entire liquid circuit on the sprayer with clean water.
9. Fill with clean water and check all functions.
10. Check function of brakes. Please note that brake power will be reduced until the rust are worn off the drums. Always brake lightly until the drums are clean.



Fault-finding Operational problems

In cases where breakdowns have occurred, the same factors always seem to come into play:

1. Minor leaks on the suction side of the pump will reduce the pump capacity or stop the suction completely.
2. A clogged suction filter will hinder or prevent suction so that the pump does not operate satisfactorily.
3. Clogged up pressure filters will result in increasing pressure at the pressure gauge but lower pressure at the nozzles.
4. Foreign bodies stuck in the pump valves with the result that these cannot close tightly against the valve seat. This reduces pump efficiency.
5. Poorly reassembled pumps, especially diaphragm covers, will allow the pump to suck air resulting in reduced or no capacity.
6. Hydraulic components that are contaminated with dirt result in rapid wear to the hydraulic system.

Therefore ALWAYS check:

1. Suction, pressure and nozzle filters are clean.
2. Hoses for leaks and cracks, paying particular attention to suction hoses.
3. Gaskets and O-rings are present and in good condition.
4. Pressure gauge is in good working order. Correct dosage depends on it.
5. Operating unit functions properly. Use clean water to check.
6. Hydraulic components are maintained clean.

TRACKER damping system

| FAULT | PROBABLE CAUSE | CONTROL/REMEDY |
|---|---|--------------------------------|
| Sprayer trails unstable | Air pockets in the hydraulic circuit | Prime hydraulic circuit |
| | Hydraulic circuit leaking | Repair leak, prime |
| | Pressure relief valve(s) set too low | Adjust pressure relief valves |
| Front hydraulic rams will not allow the yoke to turn when rear rams are extended/retracted to the maximum (MULTI TRACK) | Safety valve incorrectly adjusted | Adjust safety valve |
| Rear hydraulic rams are too tight and vehicle continues straight ahead when trying to turn | Insufficient counter weight on front of tractor | Ad ballast on front of tractor |
| | Pressure relief valve set too high | Adjust pressure relief valves |



Liquid system

| FAULT | PROBABLE CAUSE | CONTROL/REMEDY |
|------------------------------------|---------------------------------------|--|
| No spray from boom when turned on. | Air leak on suction line. | Check if suction filter O-ring is sealing. Check suction tube and fittings. Check tightness of pump diaphragm and valve covers. |
| | Air in system. | Fill suction hose with water for initial prime. |
| | Suction/pressure filters clogged. | Clean filters. Check yellow suction pipe is not obstructed or placed too near the tank bottom. |
| Lack of pressure. | Incorrect assembly. | Restrictor nozzle in Self-Cleaning Filter not fitted. Safety valve spring for Self-Cleaning Filter not tight. Too little distance between yellow suction pipe and tank bottom. |
| | | Pump valves blocked or worn. |
| | Defect pressure gauge. | Check for dirt at inlet of gauge. |
| Pressure dropping. | Filters clogging. | Clean all filters. Fill with cleaner water. If using powders, make sure agitation is on. |
| | Nozzles worn. | Check flow rate and replace nozzles if it exceeds 10%. |
| | Tank is air tight. | Check vent is clear. |
| | Sucking air towards end of tank load. | Lower pump r.p.m. |
| Pressure increasing | Pressure filters beginning to clog. | Clean all filters. |
| Formation of foam. | Air is being sucked into system. | Check tightness / gaskets / O-rings of all fittings on suction side. |
| | Excessive liquid agitation. | Reduce pump r/min. Check safety valve for Self-Cleaning Filter is tight. Ensure returns inside tank are present. Use foam damping additive. |
| Liquid leaks from bottom of pump. | Damaged diaphragm. | Replace. See Changing of valves and diaphragms. |



Hydraulic system

| FAULT | PROBABLE CAUSE | CONTROL/REMEDY |
|----------------------|---|---|
| Boom slow/eradic. | Air in system | Loosen ram connection and activate hydraulics until oil flow has no air in it (not whitish). |
| | Regulation valve incorrectly set | Open or close until desired speed is achieved (clockwise = less speed). Remember oil must be at operating temperature. |
| | Insufficient hydraulic pressure | Check output pressure of tractor hydraulics. Minimum for sprayer is 130 bar. |
| | Insufficient amount of oil in tractor reservoir | Check and top up if needed. |
| Ram not functioning. | Restrictor or regulation valve blocked | Secure boom with "S" hook. Dismantle and clean. |

EC Operating unit

| FAULT | PROBABLE CAUSE | CONTROL/REMEDY |
|--------------------------------|------------------------------|---|
| Operating unit not functioning | Blown fuse(s). | Check mechanical function of microswitches. Use cleaning/lubricating agent if the switch does not operate freely. Check motor. 450-500 milli-Amperes max. Change motor, if over. |
| | Wrong polarity. | Brown - pos. (+). Blue - neg. (-). |
| | Valves not closing properly. | Check valve seals for obstructions. Check microswitch plate position. Loosen screws holding plate a $1/2$ turn. |
| | No power. | Wrong polarity. Check that brown is pos. (+), Blue is neg. (-). Check print plate for dry solders or loose connections. Check fuse holder are tight around fuse. |



D.A.H. Hydraulic system

| FAULT | PROBABLE CAUSE | CONTROL/REMEDY |
|---|--|---|
| No boom movements when activated | insufficient oil pressure | Check oil pressure - min. 130 bar, max. 160 bar. Check tractor hydraulic oil level |
| | Insufficient oil supply. | Oil flow must be min. 10 l/min. and max. 90 l/min. Check tractor hydraulic oil level. |
| | Blown fuse. | Check / replace fuse in junction box. |
| | Bad / corroded electrical connections | Check / clean connections, multi plugs etc. |
| | Insufficient power supply. | Voltage on activated solenoid valve must be more than 8 Volts. Use wires of at least 4 mm ² for power supply. |
| | Defect relay / diodes in junction box. | Check relays, diodes and soldering at PCB in junction box |
| | Clogged restrictors B or C in by-pass block. | Remove and clean restrictors B and C in by-pass block (See hydraulic diagram) Change hydraulic oil + filter |
| | Wrong polarity. | Check polarity. White pos. (+) Blue neg. (-). |
| Boom lift raises to max. pos. when tractor hydraulics are engaged | Wrong oil inlet to by-pass block. | Connect hydraulic snap couplers opposite in tractor outlets, or engage spool valve lever in opposite direction |
| | Back pressure in return line exceeds 20 bar | Connect the return line with free flow to hydraulic oil reservoir. Divide return line in two and lead return oil back to reservoir via two spool valves. |
| Oil heats up in Closed Centre systems | By-pass valve 0 does not close properly | Check / replace locking clip on by-pass valve 0 . |
| | Internal leaks in flow regulator | Replace flow regulator O-rings and back-up rings. Replace flow regulator. |
| Individual ram does not move | Clogged restrictor | Dismantle and clean restrictor |

Tyre safety

Should it be necessary to replace tyres, it is recommended to leave this to a specialist and follow the mentioned rules.

1. Always clean and inspect the rim before mounting.
2. Always check that the rim diameter corresponds exactly to the rim diameter moulded on the tyre.
3. Always inspect inside of the tyre for cuts, penetrating objects or other damages. Repairable damages should be repaired before installing the tube. Tyres with unrepairable damages must never be used.
4. Also inspect inside of the tyre for dirt or foreign bodies and remove it before installing the tube.
5. Always use tubes of recommended size and in good condition. When fitting new tyres always fit new tubes.
6. Before mounting, always lubricate both tyre beads and rim flange with approved lubricating agent or equivalent anti-corrosion lubricant. Never use petroleum based greases and oils because they may damage the tyre. Using the appropriate lubricant the tyre will never slip on the rim.
7. Always use specialised tools as recommended by the tyre supplier for mounting the tyres.
8. Make sure that the tyre is centred and the beads are perfectly seated on the rim. Otherwise danger of bead wire tear can occur.
9. Inflate the tyre to 100-130 kPa (14.5-19 p.s.i.) then check whether both beads are seated perfectly on the rim. If any of the beads do not seat correctly, deflate the assembly and re-centre the beads before starting inflation of the tyre. If the beads are seated correctly on the rim at 100-130 kPa inflate the tyre to a maximum of 250 kPa (36 p.s.i.) until they seat perfectly on the rim.
10. Never exceed the maximum mounting pressure moulded on the tyre!
11. After mounting tyres adjust inflation pressure to operation pressure recommended by the tyre manufacturer.
12. Do not use tubes in tubeless tyres.



WARNING! Non observance of mounting instructions will result in the bad seating of the tyre on the rim and could cause the tyre to burst leading to serious injury or death!

Never mount or use damaged tyres or rims!

Use of damaged, ruptured, distorted, welded or brazed rim is not allowed!

Emergency operation of the sprayer The boom

In case of power failure the boom can be operated manually by pressing the individual buttons on the solenoid valves. This is done by locking the by-pass valve, as is done when using tractors with closed centre hydraulics.

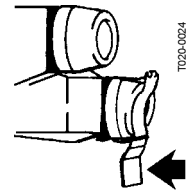

Remove the protection box of the solenoid valves at the boom. The boom can now be operated by pressing the individual buttons on the solenoid valves.

Remember to reset the system to Open Centre hydraulic, if the tractor has an Open Centre (Constant Flow) hydraulic system.

The problem may be due to a blown fuse. One spare fuse is located inside the junction box.

Fuse type: T10 A 250 V

HARDI ref. No. 261272

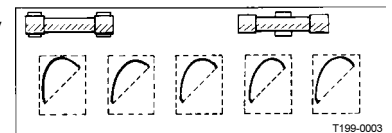

EC operating unit

In case of power failure it is possible to operate all functions of the operating unit manually. First disconnect the multi plug from the control box. Now manually turn the emergency control knobs.

The problem may be due to a blown fuse. The fuses are placed in the control box and are marked according to functions. Fuses 7 and 8 are spare fuses.

Fuse type: T 500 mA
T 1.25 A

HARDI ref. no. 261125

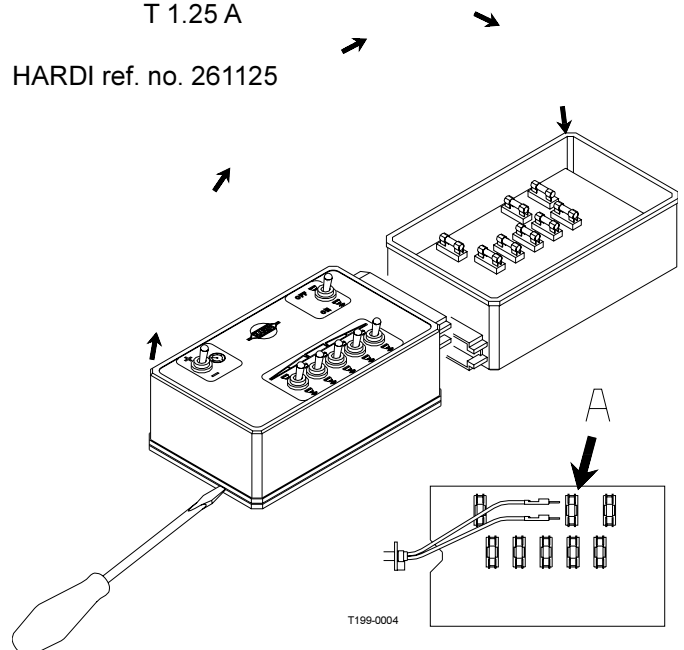

Technical specifications

Measure and weight

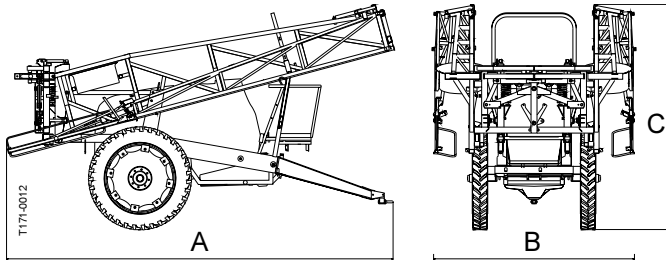

Overall dimensions

CM-2200/2800 (OLH/OLS/OLS)

| Boom width, m | A | B | C* |
|---------------|------|------|------|
| 18 | 5800 | 2980 | 3694 |
| 20 | 5800 | 2980 | 3694 |
| 21 | 5800 | 2980 | 3694 |
| 24 | 5800 | 2980 | 3694 |
| 27 | 7100 | 2980 | 3944 |
| 28 | 7100 | 2980 | 3944 |

CM-3200/4200 (OLH/OLV/OLS)

| Boom width, m | A | B | C* |
|---------------|------|------|------|
| 18 | 7100 | 2980 | 3694 |
| 20 | 7100 | 2980 | 3694 |
| 21 | 7100 | 2980 | 3694 |
| 24 | 7100 | 2980 | 3694 |
| 27 | 7100 | 2980 | 3944 |
| 28 | 7100 | 2980 | 3944 |

All measurements are in mm

* = The shown figures are based on wheel size 12.4 R46

Weights

CM-2200-OLH/OLV/OLS

| Boom width m | Empty | | | Full | | |
|--------------|--------------|-----------------|---------------|--------------|-----------------|-----------------|
| | Axle load kg | Drawbar load kg | Own weight kg | Axle load kg | Drawbar load kg | Total weight kg |
| 18 | 2165 | 436 | 2601 | 4233 | 990 | 5223 |
| 20 | 2168 | 433 | 2601 | 4235 | 988 | 5223 |
| 21 | 2182 | 439 | 2621 | 4250 | 993 | 5243 |
| 24 | 2201 | 440 | 2641 | 4268 | 995 | 5263 |
| 27 | 2125 | 576 | 2701 | 4193 | 1130 | 5323 |
| 28 | 2133 | 608 | 2741 | 4203 | 1163 | 5366 |

CM-2800-OLH/OLV/OLS

| Boom width m | Empty | | | Full | | |
|--------------|--------------|-----------------|---------------|--------------|-----------------|-----------------|
| | Axle load kg | Drawbar load kg | Own weight kg | Axle load kg | Drawbar load kg | Total weight kg |
| 18 | 2185 | 441 | 2626 | 4610 | 1083 | 5693 |
| 20 | 2187 | 439 | 2626 | 4612 | 1081 | 5693 |
| 21 | 2202 | 444 | 2646 | 4627 | 1086 | 5713 |
| 24 | 2220 | 446 | 2666 | 4645 | 1134 | 5779 |
| 27 | 2145 | 581 | 2726 | 4570 | 1223 | 5793 |
| 28 | 2152 | 614 | 2766 | 4577 | 1256 | 5833 |

CM-3200-OLH/OLV/OLS

| Boom width m | Empty | | | Full | | |
|--------------|--------------|-----------------|---------------|--------------|-----------------|-----------------|
| | Axle load kg | Drawbar load kg | Own weight kg | Axle load kg | Drawbar load kg | Total weight kg |
| 18 | 2766 | 408 | 3174 | 5675 | 1157 | 6832 |
| 20 | 2767 | 407 | 3174 | 5677 | 1155 | 6832 |
| 21 | 2784 | 410 | 3194 | 5694 | 1158 | 6852 |
| 24 | 2803 | 411 | 3214 | 5713 | 1159 | 6872 |
| 27 | 2752 | 522 | 3274 | 5662 | 1270 | 6932 |
| 28 | 2766 | 548 | 3314 | 5676 | 1296 | 6972 |

CM-4200-OLH/OLV/OLS

| Boom width m | Empty | | | Full | | |
|--------------|--------------|-----------------|---------------|--------------|-----------------|-----------------|
| | Axle load kg | Drawbar load kg | Own weight kg | Axle load kg | Drawbar load kg | Total weight kg |
| 18 | 2798 | 416 | 3214 | 6520 | 1352 | 7872 |
| 20 | 2800 | 414 | 3214 | 6522 | 1350 | 7872 |
| 21 | 2816 | 418 | 3234 | 6538 | 1354 | 7892 |
| 24 | 2835 | 419 | 3254 | 6557 | 1355 | 7912 |
| 27 | 2785 | 529 | 3314 | 6507 | 1465 | 7972 |
| 28 | 2798 | 556 | 3354 | 6521 | 1491 | 8012 |

NOTE! All weights are approximate values, and based on machines equipped with rinsing tank, 12.4R46" wheels, brakes and HARDI FILLER. (1 kg = 2.2 lb).

For MULTI TRACK and SELF TRACK models the values in above tables must be increased as follows:

Empty: + 255 kg on Drawbar and Total weights

Full: + 400 kg on Drawbar and Total weights

NOTE! Additional weight (own weight) for COMMANDER with suspension:

COMMANDER 2200/2800: + App. 220 kg.

COMMANDER 3200/4200: + App. 250 kg.



Pump capacity

463/10.0

| bar | Rotation per min | | | | | |
|----------------|------------------|-----|-----|-----|-----|-----|
| | 200 | 300 | 400 | 500 | 540 | 600 |
| Capacity l/min | | | | | | |
| 0 | 109 | 156 | 207 | 257 | 276 | 305 |
| 2 | 103 | 152 | 202 | 252 | 270 | 299 |
| 4 | 101 | 149 | 198 | 246 | 265 | 295 |
| 6 | 99 | 146 | 195 | 424 | 263 | 289 |
| 10 | 94 | 142 | 192 | 236 | 256 | 282 |
| 15 | 91 | 136 | 184 | 230 | 248 | 276 |

Max. pressure: 15bar Weight: 66.5 kg Suction height: 0.0 m

Ground clearance (under axle) for COMMANDER with suspension:

COMMANDER 2200/2800: 600 mm (9.5 x 44" wheels)
 COMMANDER 3200/4200: 750 mm (12.4 x 46" wheels)

Filters and nozzles

Filter gauze width

30 mesh: 0.58 mm 50 mesh: 0.30 mm
 80 mesh: 0.18 mm 100 mesh: 0.15 mm

Temperature and pressure ranges

Operating temperature range:
 2° to 40° C. (36°F to 104°F)

Operating pressure for safety valve:
 15 bar (220 psi)

Max. pressure on the pressure manifold:
 20 bar (290 psi)

Max. pressure on the suction manifold:
 7 bar (100 psi)

Brakes

Max. wear rates on brake components, mm (in)

| Model | 2200/2800 | 3200/4200 |
|-------------------------|---------------|---------------|
| Max. drum diameter A | 302 (11.8897) | 402 (15.8388) |
| Min. lining thickness B | 2.0 (0.07874) | 4.0 (0.15748) |

Hydraulic brakes

Max. hydraulic pressure: 150 bar (2176 p.s.i.)

Air brakes, single line:

Air pressure, relieved brakes: 5.3 - 5.6 bar
 Air pressure drop to activate: 0.8 - 1.3 bar

Air brakes, dual line

Load apportioning valve pressure settings:

Relieved: 0 bar
 Empty: 1.6 bar (23.2 p.s.i.)
 Half: 3.4 bar (49.3 p.s.i.)
 Full: Air tank pressure

Electrical connections

Rear lights

| Position | Wire colour |
|---------------------------|-------------|
| 1. LH direction indicator | Yellow |
| 2. Free | Blue |
| 3. Frame | White |
| 4. RH direction indicator | Green |
| 5. RH rear position lamp | Brown |
| 6. Stop lamps | Red |
| 7. LH rear position lamp | Black |

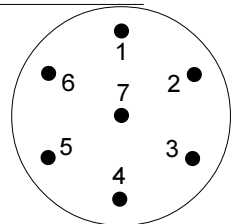

The wiring is in accordance with ISO 1724.

EC

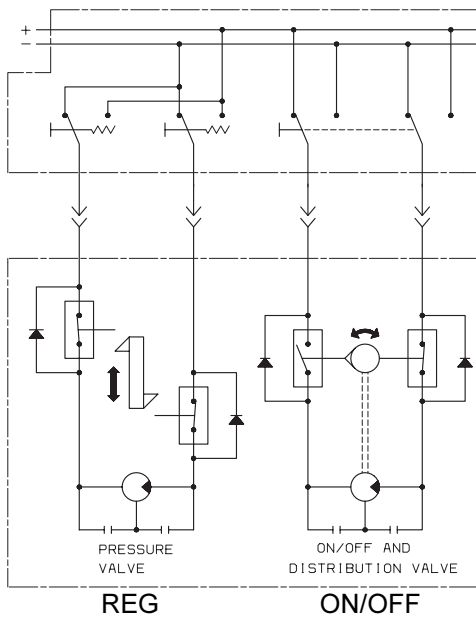

copy of EIdiagram BK/EC

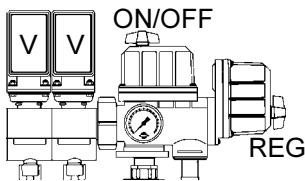

armatur EC 2B(L)

Number of distribution valves

2/3/4 5/6 7

| Valve | Wire number or color code | | |
|--------|---------------------------|--------|-------|
| V1 | 1-2 | 1-2 | 1-11 |
| V2 | 3-4 | 3-4 | 2-12 |
| V3 | 5-6 | 5-6 | 3-13 |
| V4 | 7-8 | 7-8 | 4-14 |
| V5 | | 9-10 | 5-15 |
| V6 | | 11-12 | 6-16 |
| V7 | | | 7-17 |
| REG | 9-10 | 13-14 | 9-10 |
| ON/OFF | 11-G/Y | 15-G/Y | 8-G/Y |

The EC operating unit fulfils the EC noise reduction standards.

Materials and recycling

- Tank: HDPE
- Hoses: PVC
- Valves: mainly glass-filled PA.
- Fittings: PA

Disposal of the sprayer

When the equipment has completed its working life, it must be thoroughly cleaned. The tank, hose and synthetic fittings can be incinerated at an authorised disposal plant. The metallic parts can be scrapped. Always follow local legislation regarding disposal.

Conversion factors, SI to Imperial units

All units used in this manual are SI units. In some occasions Imperial units are used. Use following factors to convert SI units to Imperial units:

| | SI unit | Imperial unit | Factor |
|-----------------|---------|---------------------------------|-----------------|
| Weight | kg | lb. | x 2.205 |
| Surface area | ha | acres | x 2.471 |
| Length | cm | in | x 0.394 |
| | m | ft | x 3.281 |
| | m | yd | x 1.094 |
| | km | mile | x 0.621 |
| Velocity | km/h | mile/h | x 0.621 |
| | km/h | m/s | x 0.277 |
| Quantities/area | l/ha | gal (Imp.) | x 0.089 |
| | | /acre | |
| Volume | ml | fl. oz (Imp.) | x 0.0352 |
| | l | Imp. pt. | x 0.568 |
| | l | gal (Imp.) | x 0.22 |
| Pressure | bar | lb./in ² (p.s.i.) | x 14.504 |
| Temperature | °C | °F | (°C x 1.8) + 32 |
| Power | kW | hp | x 1.341 |
| Torque | Nm | lbft | x 0.74 |

Boom hydraulic OLV (with Multi Track)

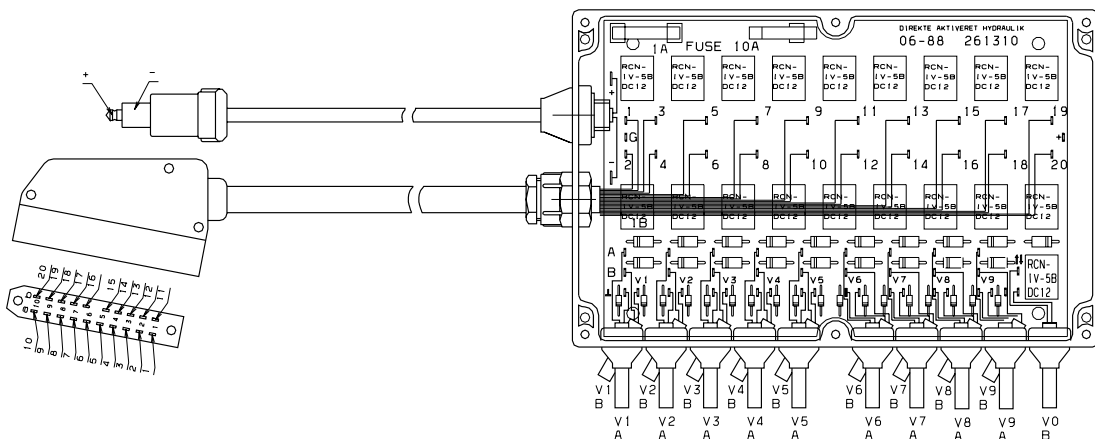
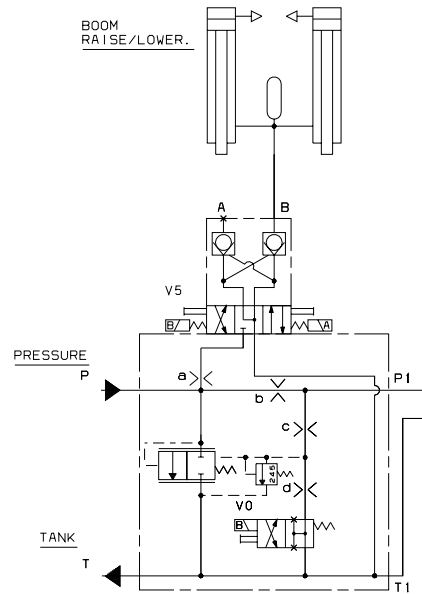
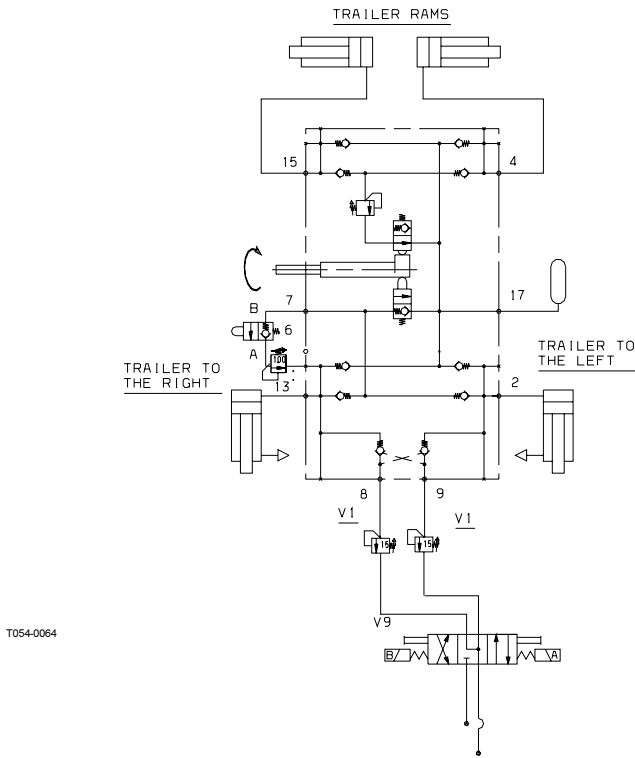
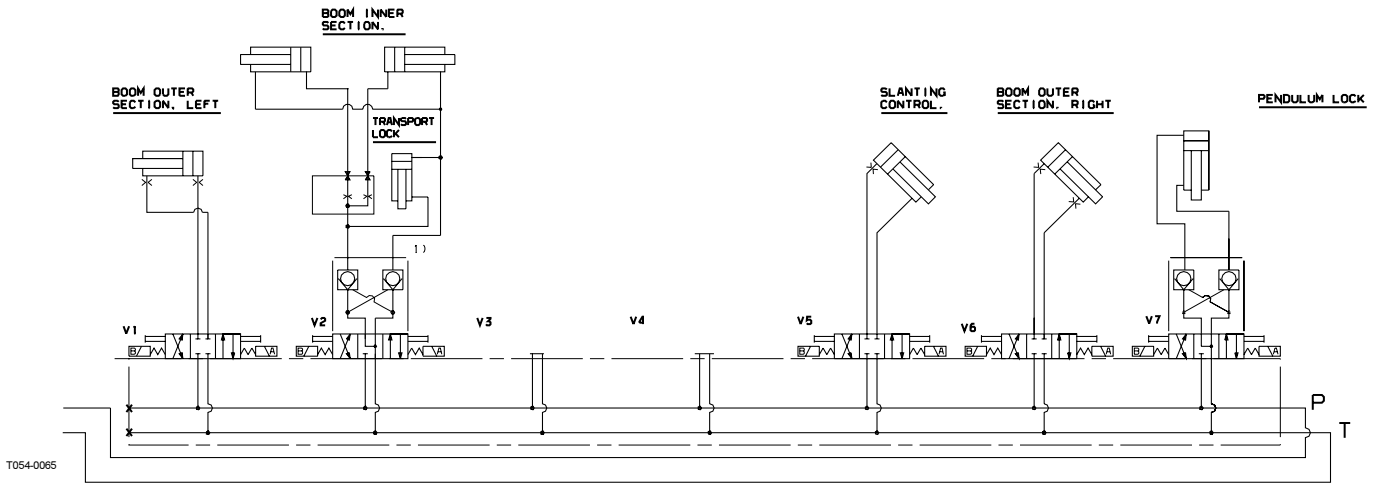

Boom hydraulic OLV (with STEER TRACK)

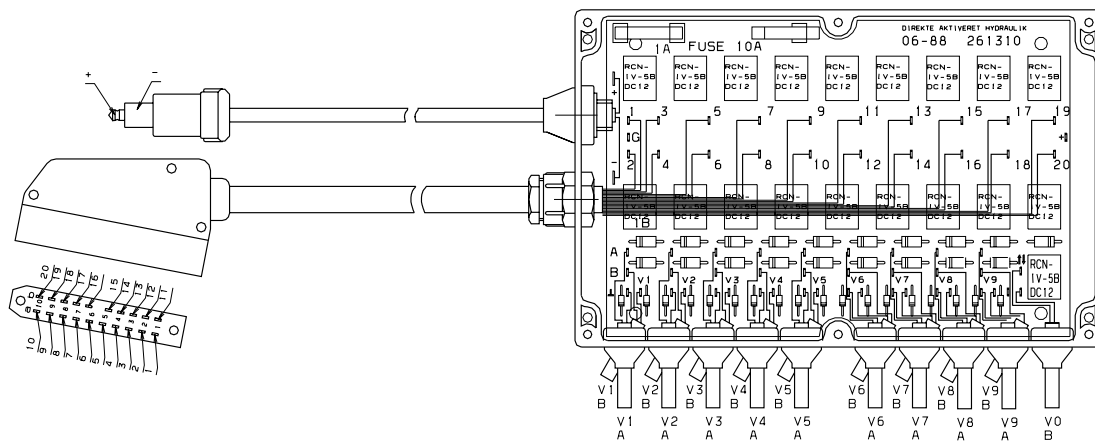
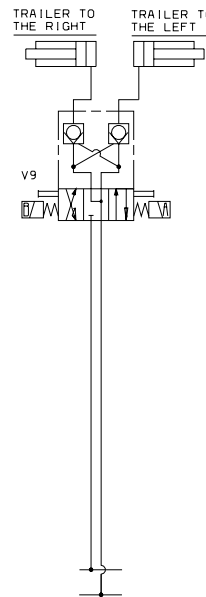
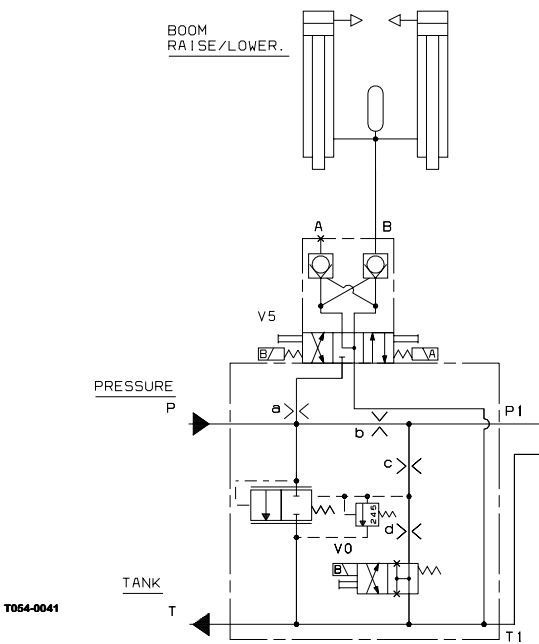
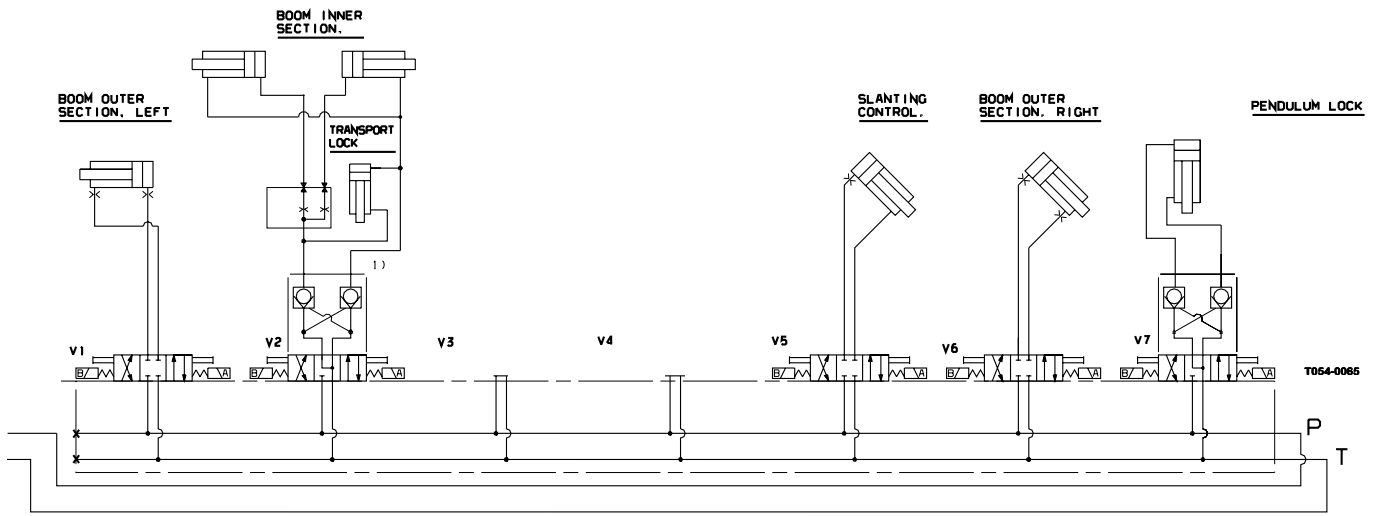

Boom hydraulic OLV

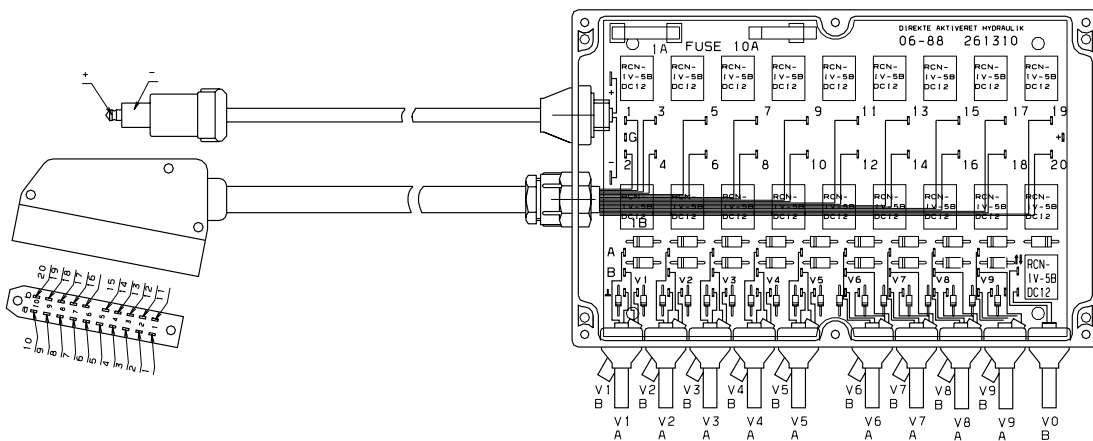
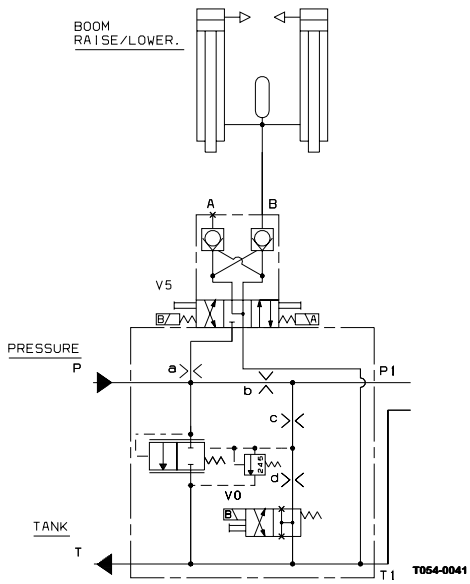
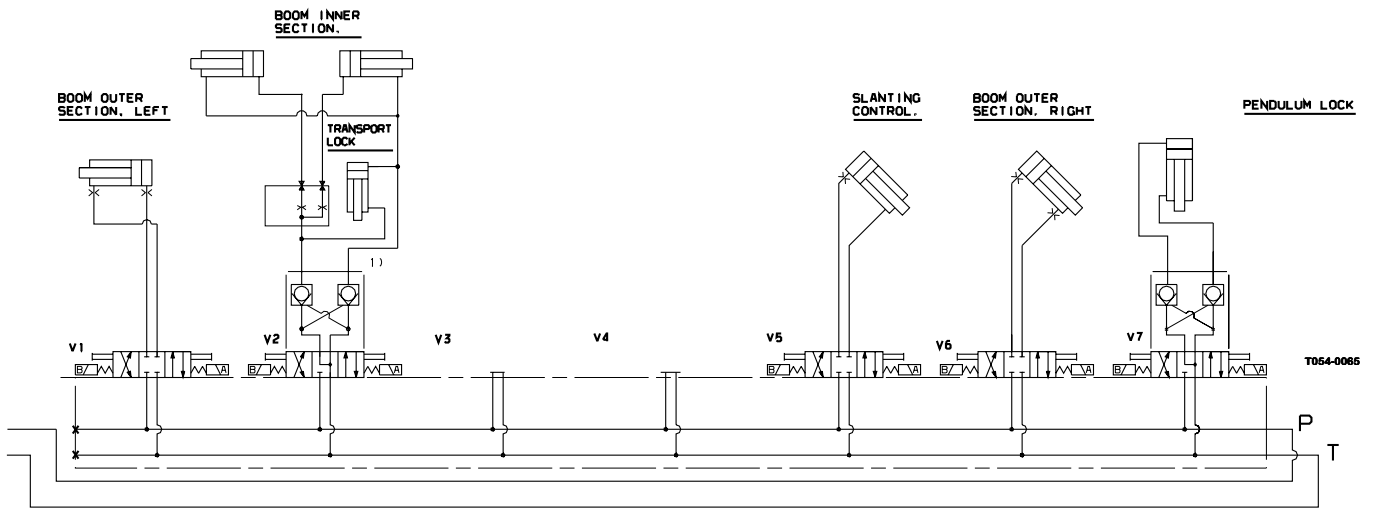

Boom hydraulic OLH (with STEER TRACK)

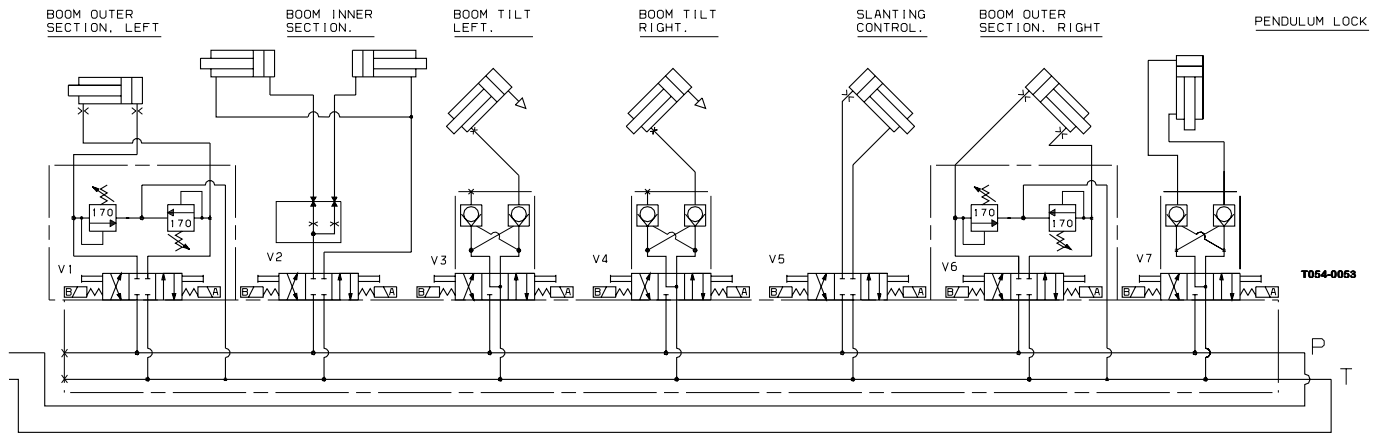

T054-0053

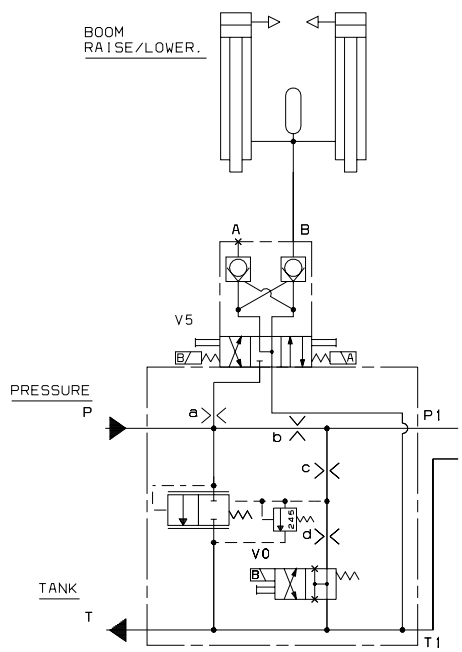

T054-0041

T054-0036

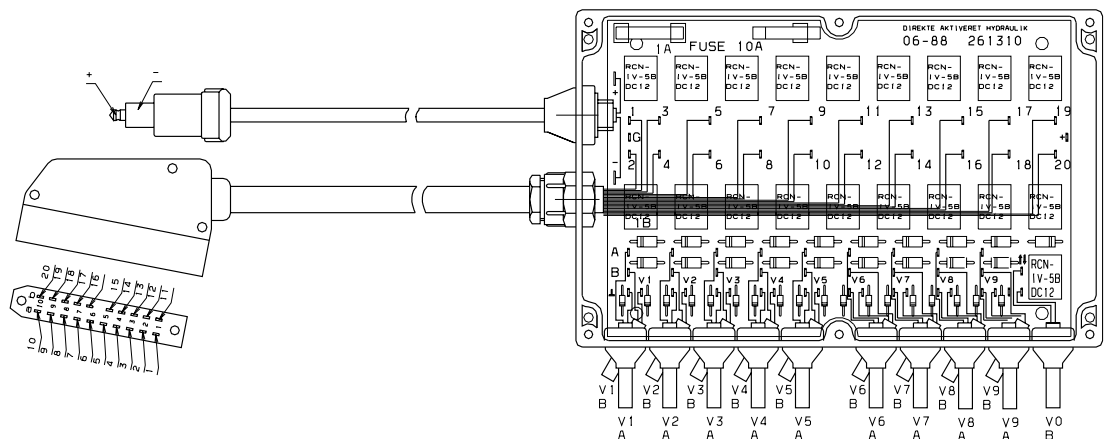

T059-0006

Boom hydraulic OLH (with MULTI TRACK)

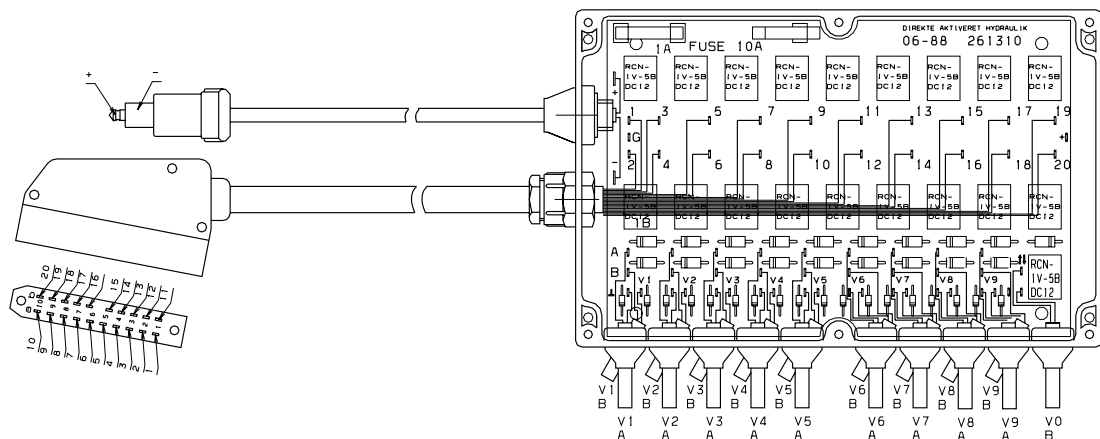
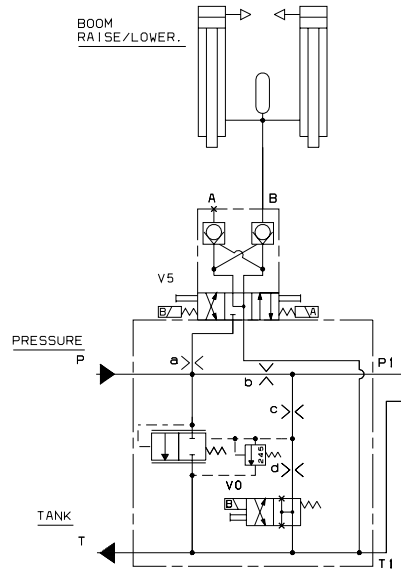
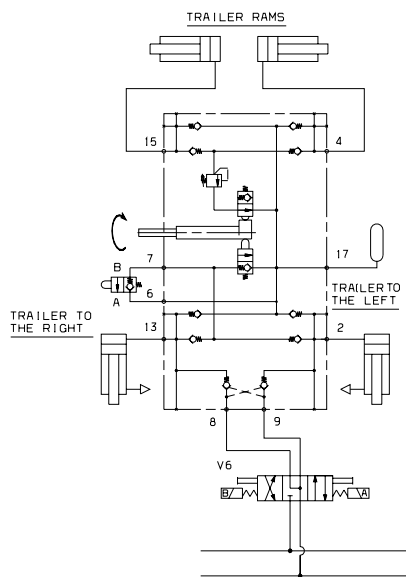
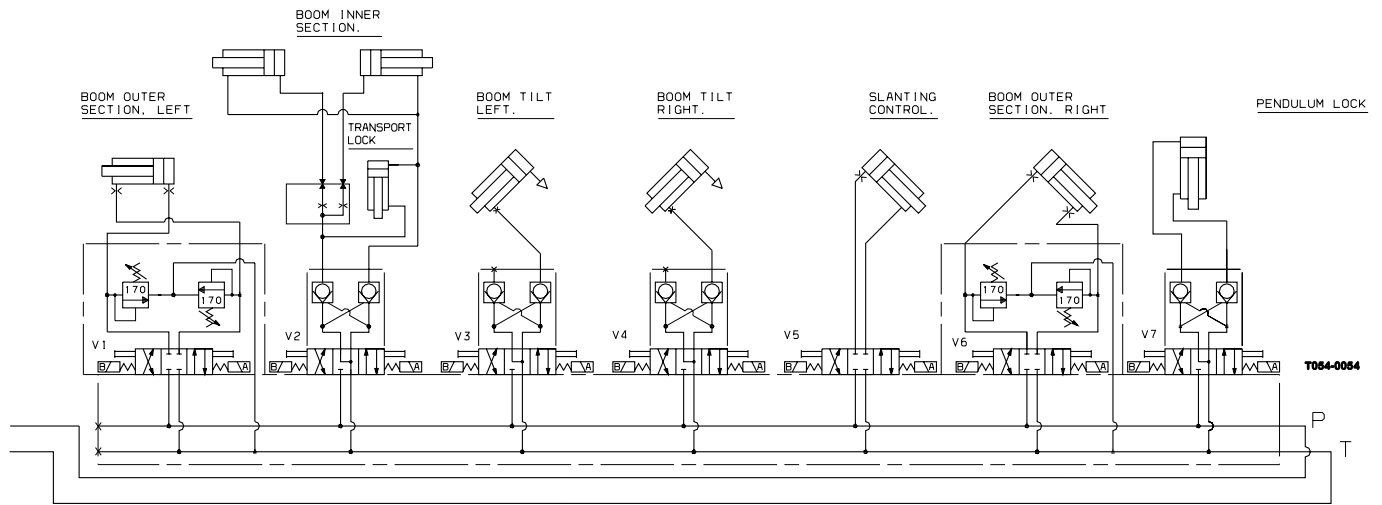

Boom hydraulic OLS

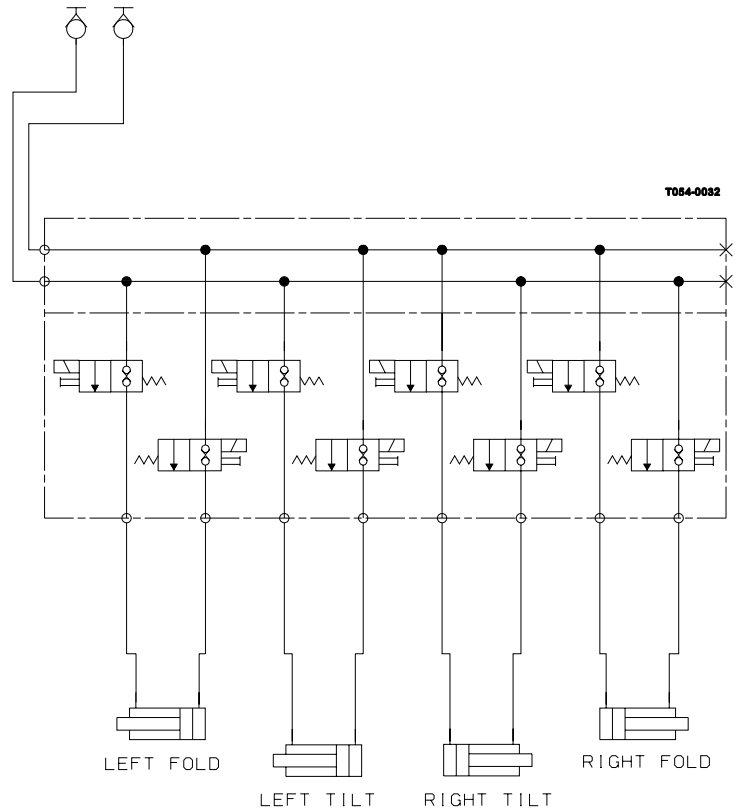

Wiring diagram OLS

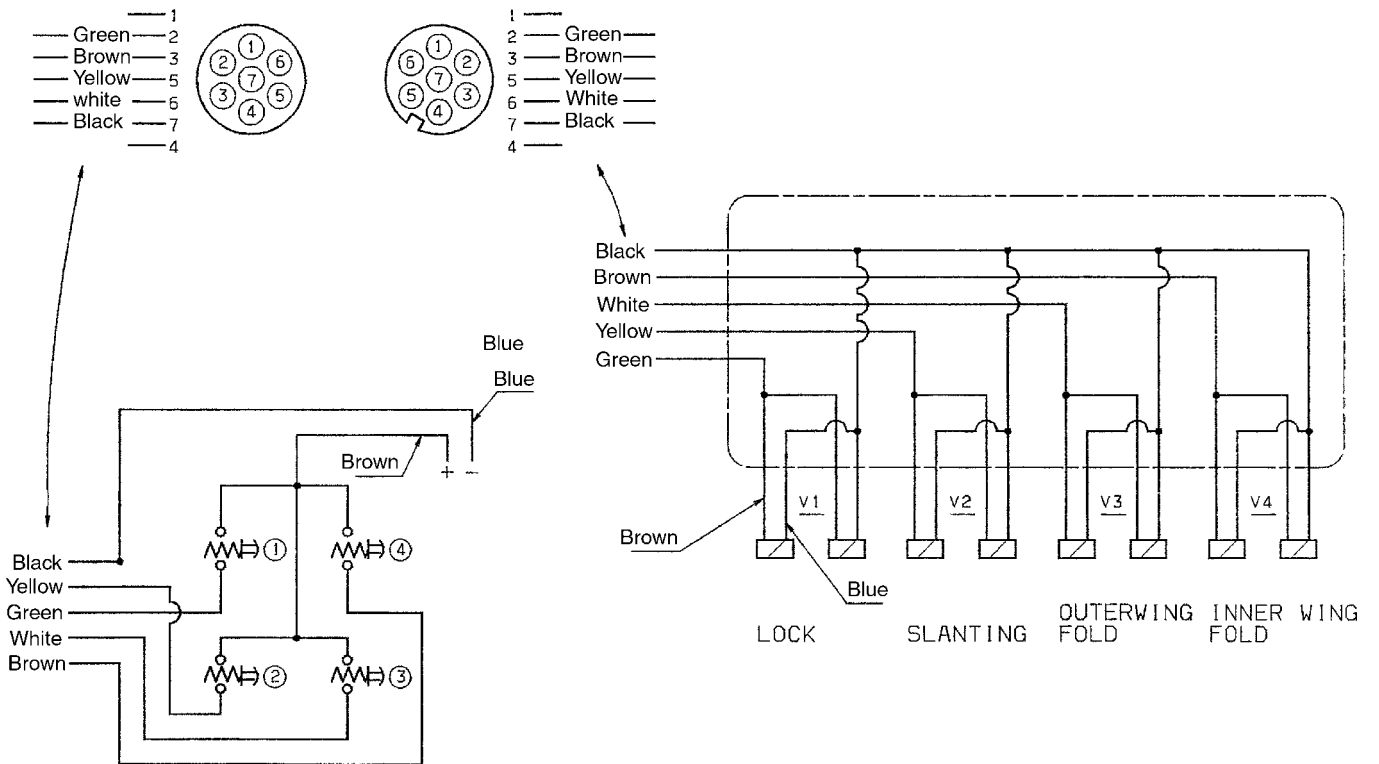

T058-0013



Subject index

A

Air activated brakes 12
Air brake filters 39
Air brakes 37
Air in system 51
Altering track gauge 10
Anti-freeze 49
AXIAL connection 47

B

Ball seat 44
Ball valve 25
Black disc 20
Blown fuse 53, 54
Blue disc 20
Boom 5
Boom alignment 41
Boom slow/eradic 52
Brake operating arm 11
Brakes 12, 36, 38
Breakaway 42

C

CaCl₂ 15
Centre rim 10
Chemicals 25, 29
Circuit leak 50
Clean water tank 23
Cleaning procedure 31
Clogged restrictor 53
CLOSED CENTRE 14
Cone 44
Control box 14
Conversion factors 57
Counter weight 15
Cross journals 48

D

D.A.H. system 14, 53
Damping pressure setting 46
Diaphragm 44
Disposal of pesticides 31
Distribution block 14
Draw bar bolts 37
Drawbars 7
Driving Technique 16
Dual-line brakes 12

E

EC Declaration 4
EC operating unit 23, 24, 52, 54, 57
Electrical connections 56
Emergency brake 12
Emergency operation 54
End stop valve 42
Expansion bottle 37, 39

F

Fast Filling Device 22
Fault-finding 50
Filling of chemicals 25
Filling of water 21
Filter gauze 36
Filters 5, 24
Fittings 47
Formation of foam 51
Frame 5
Front articulating points 45
Function diagram 20
Fuse 54

G

Green disc 20

H

HARDI FILLER 26
HARDI-MATIC 5
Height setting 13
Hitch 7
Hose package 30
Hub flange 10
Hydraulic activated brakes 12
Hydraulic brakes 39
Hydraulic circuit 39
Hydraulic leaks 14
Hydraulic system 14, 52

I

I.A.H. system 19
Identification plates 5
Imperial units 57
In-Line filter 36

J

Joystick 19



L

Lack of pressure. 51
Ladder 8
Level indicator 47
Linear adjustment 41
Liquid chemicals 26
Liquid leaks 51
Liquid system 51
Liquid-filled tyres 15
Lubricants 32

M

Maintenance 31
MANIFOLD SYSTEM 5, 20
Max. pressure 56
Max. transport height 13
Measure 55
Multi plug 54
MULTI TRACK 8, 16

N

No boom movements 53
No spray from boom 51
Nominal contents 5
Normal trailing mode 17
Nozzle filters 36
Nozzle tube 47
Nozzles 56

O

O-ring 47
Occasional maintenance 44
Off-season storage 49
Oil heats up 53
Oil pressure 53
OLH boom 18
OLS boom 19
OLV boom 18
OPEN CENTRE 14
Operating pressure 56
Operating temperature 56
Operating unit 5
Operational problems 50
Operator safety 4
Overall dimensions 55

P

P.T.O. 5
P.T.O. shaft 9
Parking brake 12, 30, 39
Parking brake cables 39
Pendulum 5

Pendulum suspension 42
Personal protection 29
Pesticide washings 31
Platform 8
Position lamp 6
Powder chemicals 27
Power failure 54
Power supply 14, 53
Ppressure gauge 24
Pressure increasing 51
Pressure range 56
Pressure valve 20
Priming 46
Protection film 6
Protection guards 48
Protective clothing 31
Pump 5
Pump capacity 56
Pump valve 44

R

RADIAL connection 47
Ram not functioning 52
Rear lights 6, 56
Recycling 57
Remote pressure gauge 24
Replace tyres 54
Restrictor 25
Return valve 20
Rinsing nozzles 28
Rinsing tank 23, 28
Rinsing tank drain valve 29
Roadworthiness 6

S

Safe sprayers 31
Safety valve 39, 50
SELF TRACK 8, 16
Self-Cleaning Filter 25, 36
Service 35
Shipping package labels 4
Shock absorbers 46
SI 57
Single-line brakes 12
Sprayer trails unstable 50
Spraying circuit 36
Stability 10
STEER TRACK 7, 16
Stop wedges 8, 30
Suction Filling Device 21
Suction filter 36
Suction valve 20
Support leg 7
Suspension 36



T

Tank 5
Tank drain valve 29
Tank lid 21
Technical Residue 28
Temperature 56
Track correction mode 17
Track gauge 10, 11
TRACKER damping system 50
Tracking mode 17
Tractor's remote control lever 19
Trailer coupling 7
Transmission shaft 9, 37, 43, 48
Transmission shaft support 30
Transport brackets 13
Tyre 54
Tyre pressure 37
Tyre safety 54

U

Unloading the sprayer 6

W

Wear bush 45
Wear rates 56
Weight 55
Wheel bearings 38
Wheel bolts 37
Wheel brake 38



Notes:

