

TZ

Instruction book

674900-GB-92/11

Contents

Description	2
Connecting the sprayer	4
Drawbar	4
Track gauge and clearance	5
Boogie axle (if fitted)	5
Hydraulics	5
Control boxes and power supply	6
Parking brake (if fitted)	7
Hydraulic activated brakes (if fitted)	7
Pneumatic activated brakes (if fitted)	8
Transmission shaft	8
Steering axle (if fitted)	9
Track correction (if fitted)	10
Boogie axle (if fitted)	11
Operating instructions	12
Operating of the boom	12
Self-cleaning filter	14
Adjustment of the controls	15
Maintenance	18
Lubrication	18
Re-adjustment of the Boom	26
Recommended tyre pressure	30
Wheel nuts and bearings	31
Adjustment of brakes	32
Filters	33
Changing of valves and diaphragms	34
Level indicator	35
Changing of ball seat in operating unit	35
Check of valve cone in distribution valves	36
Nozzle tubes and fittings	36
Off-season storage	37
Technical specifications	42
Assembly	49

TZ

Instruction book

674900-GB-92/11

HARDI INTERNATIONAL A/S reserve the right to make changes in design or to add new features without any obligation in relation to implements purchased before or after such changes.



We congratulate you for choosing a HARDI plant protection product. The reliability and efficiency of this product depend on your care. The first step is to carefully read and pay attention to this instruction book. It contains essential information for the efficient use and long life of this quality product.

As the instruction book covers all TZ models, please pay attention to the paragraphs dealing with precisely your model. This book is to be read in conjunction with the "Spray Technique" book.



Description

The Hardi TZ models consist of a pump, frame with adjustable wheel track gauge, 1500, 2400 or 3500 litre tanks, self-cleaning filter, EC operating unit, LHZ 12, 15, 16, 18 metre or MHZ 20, 21, 24 or 28 metre fully hydraulic operated spray boom and transmission shaft. Some models have parking- hydraulic- or pneumatic activated brakes and steering axle as factory fitted optional extras.

The design of the diaphragm pump is simple, with easily accessible diaphragms and valves that ensures liquid does not contact the vital parts of the pump.

The tank, made of impact-proof and chemical resistant polyethylene, has a purposeful design with no sharp corners, for easy cleaning.

The EC operating unit consists of: on/off valve, pressure control valve with built-in HARDI-MATIC, pressure gauge and distribution valves with pressure equalization.

HARDI-MATIC ensures a constant volume per ha of the liquid at varying speed in the same gear. The number of revolutions on the P.T.O. must be kept between 300-600 r/min.

With the self-cleaning filter the impurities that exist in the spray liquid will by-pass the filter and be recirculated back to the tank via the return to tank.

The LHZ/MHZ spray boom is fully hydraulic folded and operated. Individual folding of right and left outer sections enable alternative boom widths. Individual boom tilt function for right and left side adapts boom height to slopping terrain. Slanting control for trapeze suspension compensates for driving on hillsides. All functions are controlled by Direct Acting Hydraulic system (D.A.H.). The outer sections incorporate spring loaded breakaways.

Identification plates

An identification plate fitted on the frame and pump is to indicate model, year of production with serial number and country of origin. Boom centre frame, and inner/outer sections also have identification plates indicating boom type and part no. of steel parts. If ordering spare parts, inform your dealer of these so the right model and version are described.

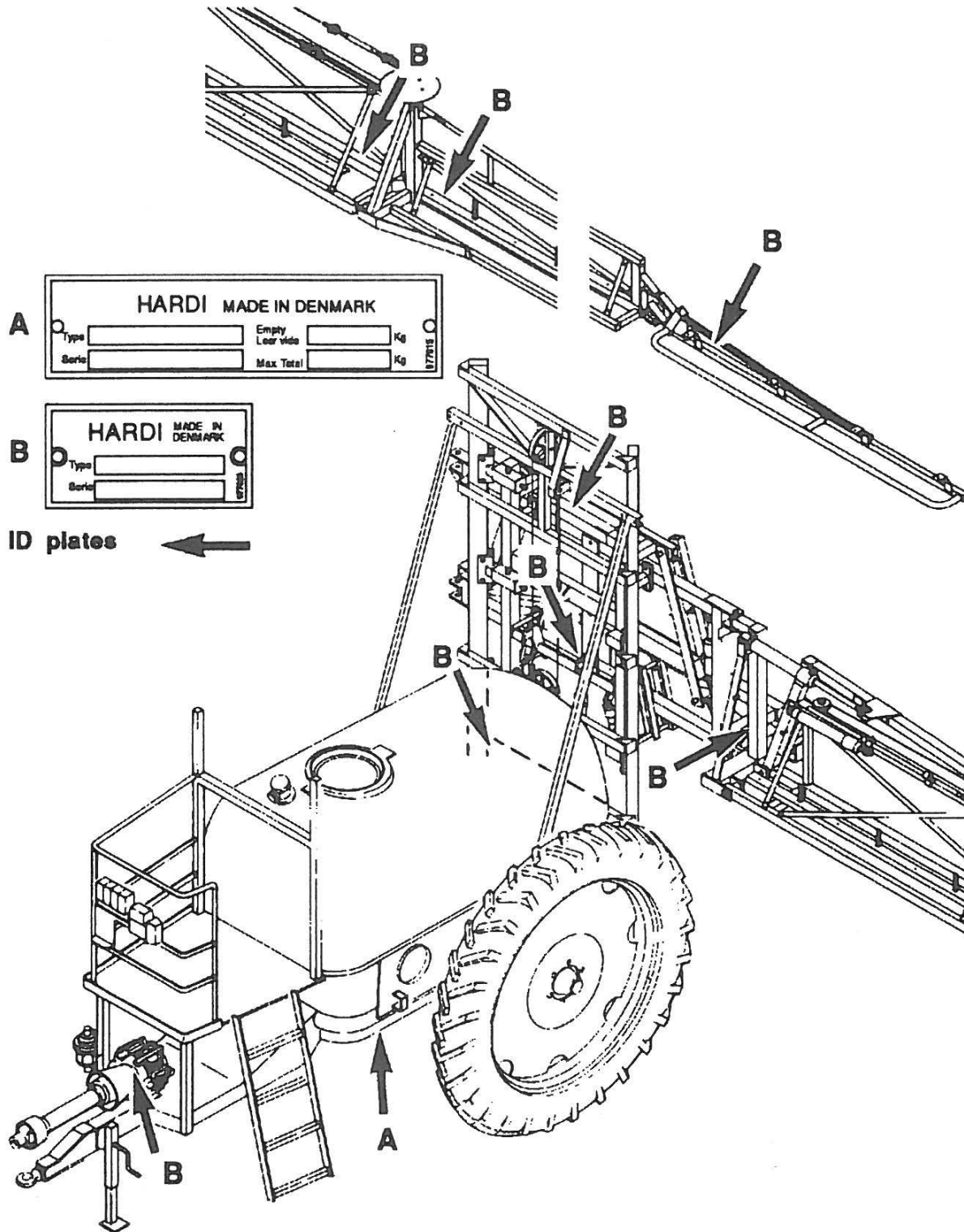

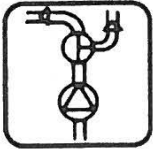

Operation diagram

1. Suction filter
2. Pump
3. Self-cleaning filter
4. Safety valve
5. Pressure agitator
6. On/off valve with pressure gauge
7. Pressure control valve with HARDI-MATIC
8. Distribution valve with pressure equalization
9. By-pass agitation
10. Sprayer boom.

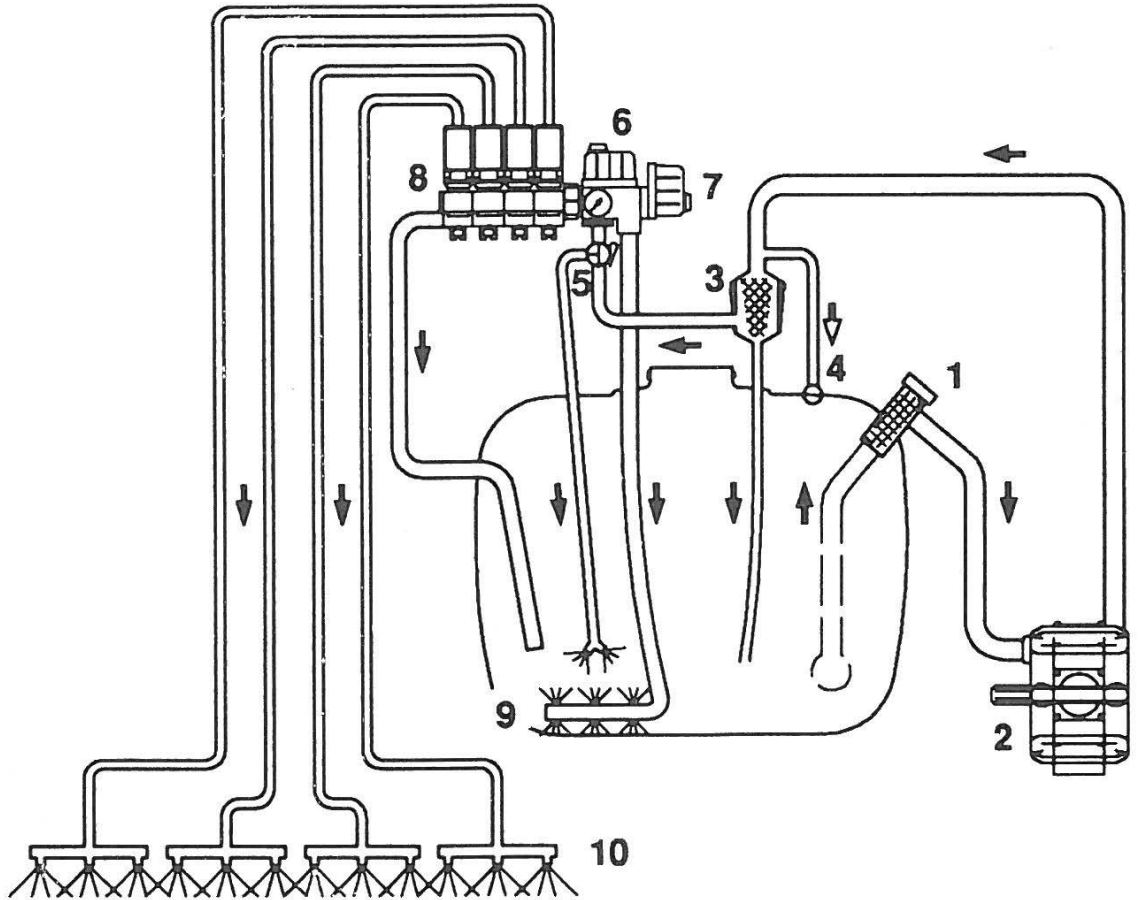

Connecting the sprayer

Drawbar

The drawbar is equipped with 36 mm swivel towing ring. Two bolts connect the drawbar to the chassis. Extra bolt holes permit different positions to suit tractor hitch.

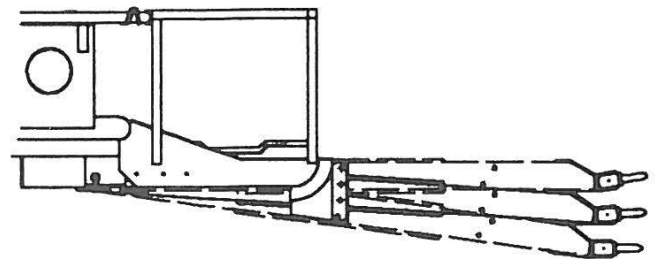

Drawbar is set so the chassis is parallel to the ground.



WARNING: Trailer frame must be supported before adjusting drawbar position.

After the drawbar is connected, the jack is folded up.

Track gauge and clearance

The track gauge of the trailer can be varied between 1.4 m to 2.1 m depending on model. The two nuts are loosened, and thereafter the hub bracket can be drawn out or pushed in, until the required track gauge is obtained.

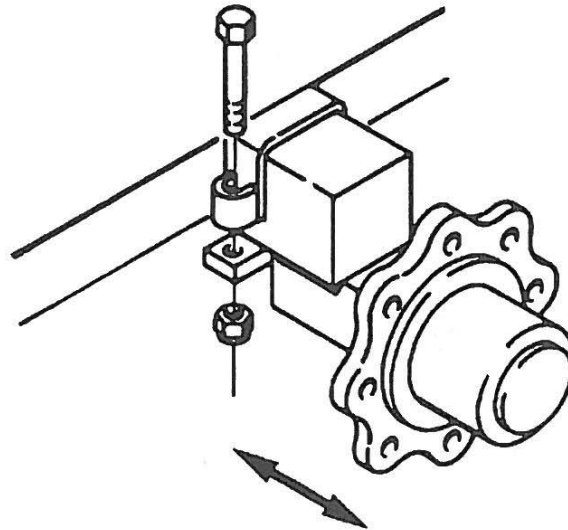

Ground clearance can be reduced by rotating the axles 180°.

Boogie axle (if fitted)

On models with boogie axle, the track gauge can be set by turning and changing the position of rims and rim plates.

Following track gauge settings can be obtained.

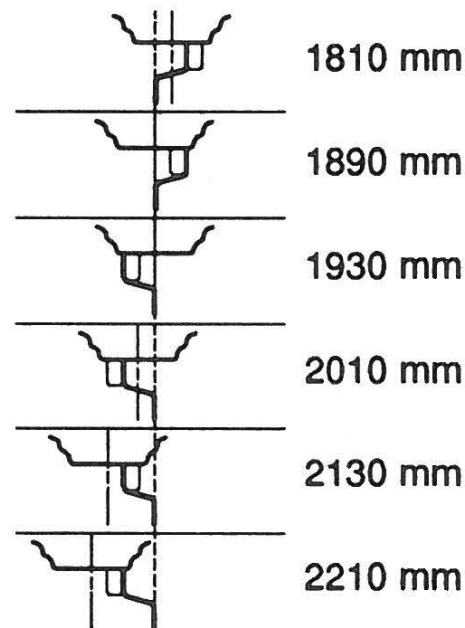

Hydraulics

Hydraulic connection requires one double acting outlet for the D.A.H. system. A single outlet and return can also be used. The hydraulic hoses are marked with an arrow to indicate direction of oil flow.

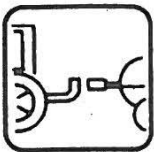

The D.A.H. system requires an oil flow between 10 to 90 litres per minute and a min. pressure of 130 bar. The system has a built-in flow regulator that maintains constant speed on hydraulic movements.



Before operating the hydraulics, the clip at the distribution valve (situated under the platform behind the pump) should be set for OPEN or CLOSED CENTRE tractor hydraulics.

Most tractors have OPEN CENTRE hydraulics and the valve must be open for continuous oil circulation. For CLOSED CENTRE hydraulics (e.g. JOHN DEERE) the clip must hold the valve closed so oil only circulates when hydraulic movements are required.

Setting of distribution valve.

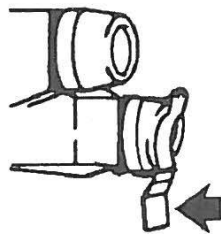

CLOSED CENTRE

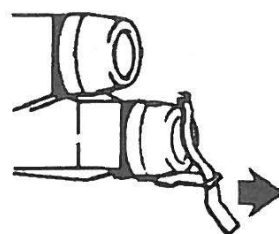

OPEN CENTRE



Control boxes and power supply

Power requirement is 12 V DC. Note polarity!

For EC: Brown pos. (+), Blue neg. (-).

For D.A.H.: White pos. (+), Black neg. (-).



The control boxes for EC-operating unit and for D.A.H. are fitted in the tractor cabin at a convenient place. See section on Assembly for initial mounting.

The wires must have a cross-sectional area of at least 4.0 mm² to ensure sufficient power supply. For the EC-operating unit the tractor circuit should have a 8 Amp fuse and for the D.A.H. a 16 Amp fuse.

Use the HARDI Electric distribution box (No. 817925) if the tractor has a doubtful power supply.

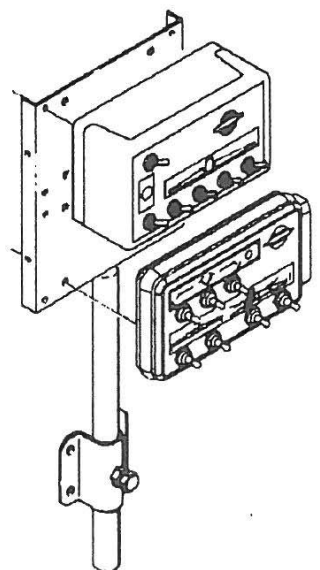

Rear lights (if fitted)

Connect plug for rear lights to the tractor's 7-poled socket and check that rear lights, stop lights and turning indicators work.



Parking brake (if fitted)

After the sprayer is connected, release the parking brake by pushing the thumb button in and pushing the lever forward. It is recommended to always use the parking brake before disconnecting the sprayer.

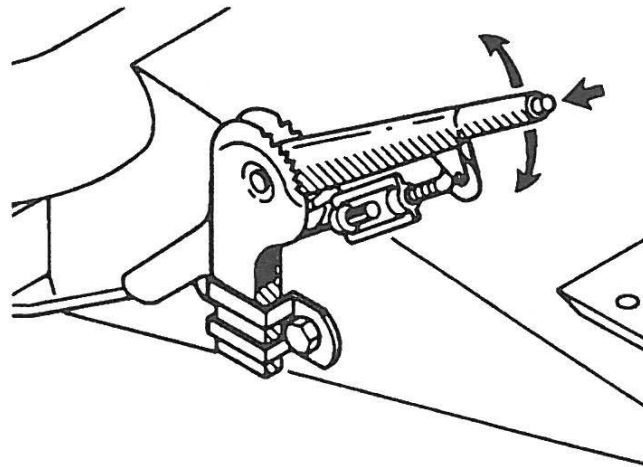

Hydraulic activated brakes (if fitted)

This requires a special trailer brake valve **A** attached to the tractor hydraulic and brake system. Connect the snap coupler to the tractor brake outlet. When the tractor brakes are applied, the trailer brakes will work proportional to the tractor brakes and ensure safe and efficient braking. **Max. Inlet oil pressure: 8 bar.** Release the parking brake before driving.

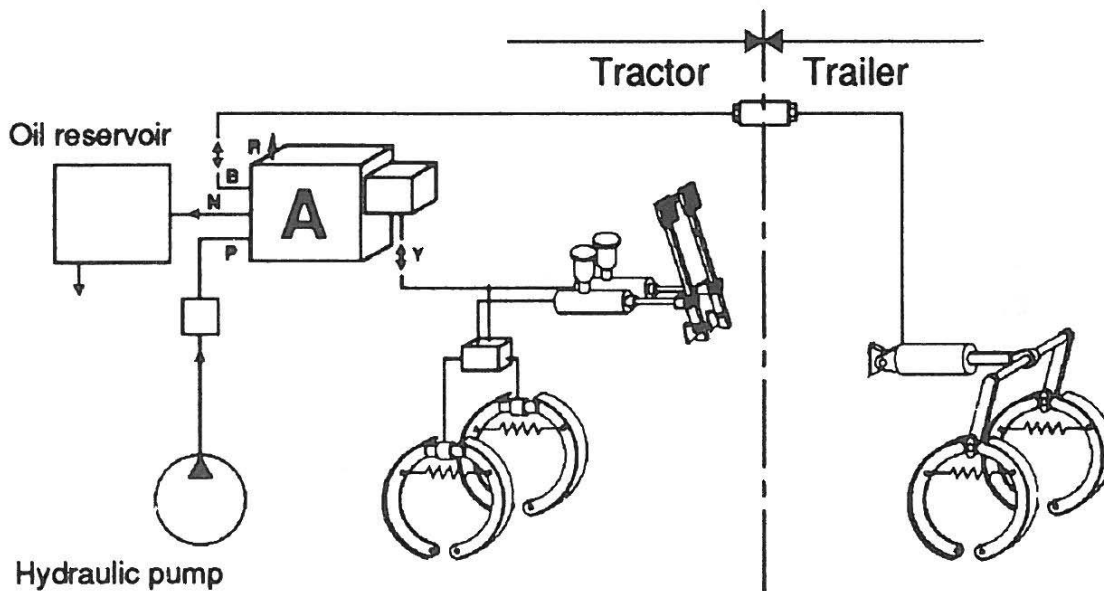

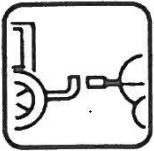

Pneumatic activated brakes (if fitted)

This system requires a tractor with compressor and pneumatic brake system with outlets for trailer brakes. Connect the brake system snap coupler to the tractor outlet and let the compressor fill the sprayer's air reservoir. Release the parking brake before driving.

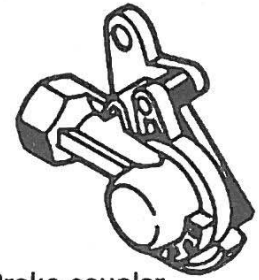

Brake coupler



IMPORTANT! If a load valve is fitted, this must be set at correct position. Set to obtain optimal air pressure to trailer brakes.

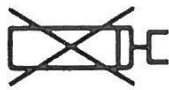

= Released



= Half full tank



= Empty tank



= Full tank

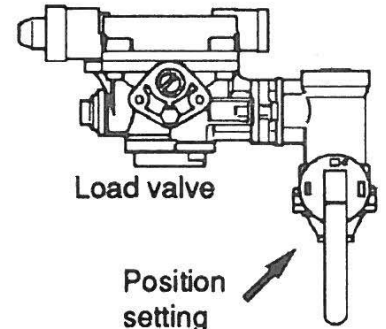

Load valve

Position setting



DANGER! Driving with wrong load valve setting will cause the brakes to under- or overapply, which can result in dangerous situations.

Transmission shaft

When connecting the sprayer to the tractor the length of the transmission shaft should be checked and if necessary shortened. There should be at least 150 mm free play between the male and female parts when the shaft is horizontal. When connected, check by turning sharply. Do this with caution. There should be at least 10 mm between male and female parts when the shaft is at its minimum length.

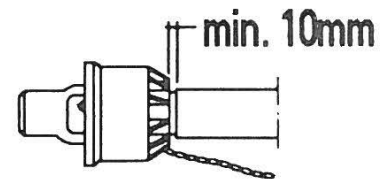
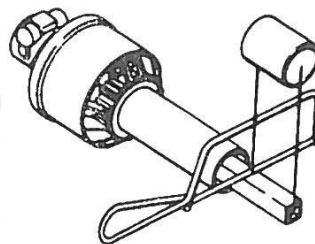
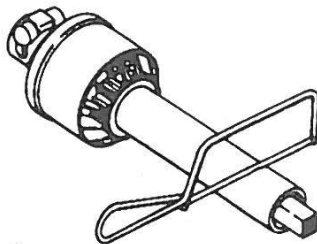

min. 10mm

To ensure long life of the transmission shaft, try to avoid working angles greater than 15° and turning angles greater than 70°.

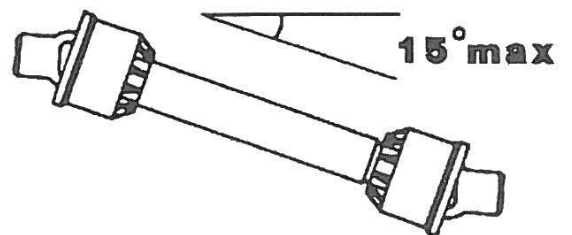

15° max

It is important for the personal safety of the operator that the transmission shaft is intact. The protection guards must cover the whole shaft. This includes the universal cross covers at each end of the shaft. The chains are connected so that the protection guards do not rotate with the shaft.

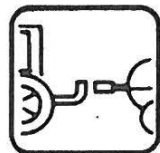
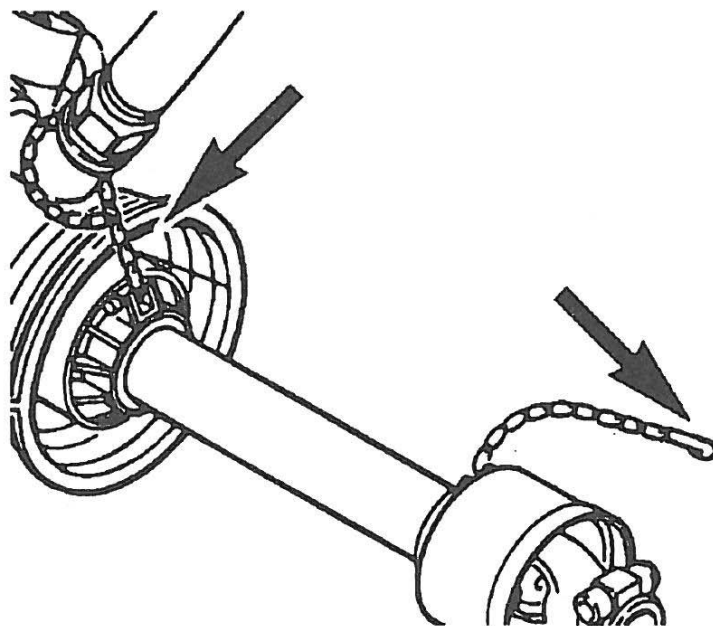

Steering axle (if fitted)

1. Adjustment of track width

A - Track width measured at ground level.

B is to equal C.

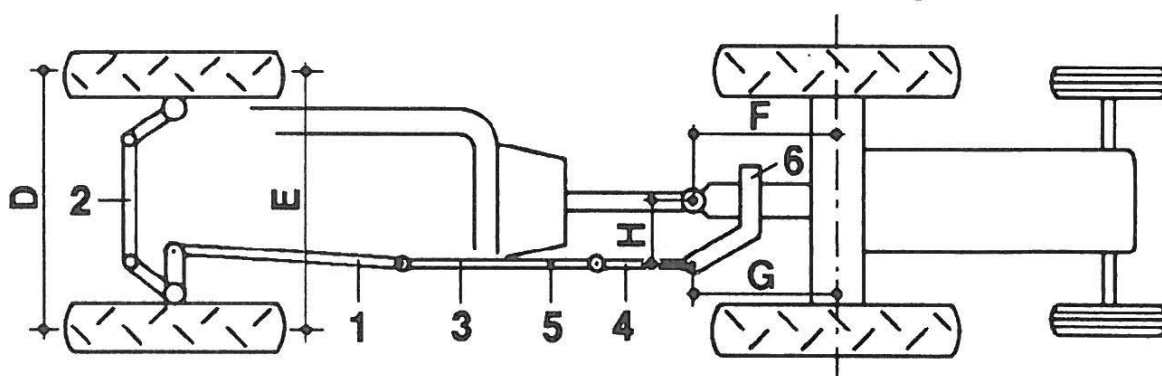
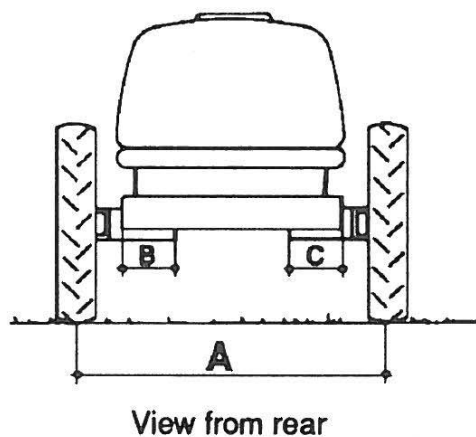

2. Adjustment of wheels (toe-in)

Adjust wheels so D is 10 mm longer than E. D and E are to be measured at the centre of tyre at wheel hub level front and rear. The adjustments are carried out by shortening and extending the rods 1 and 2.

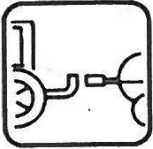

3. Adjustment of tractor/trailer connection

1. Fit the activating bracket 6 to the tractor's drawbar so $F = G$ and $H = 200$ mm
2. Unlock rod 3 by removing lock pin 5.
3. Adjust length of rod 4 utilizing lock pin 5 and connect to tractor.
4. Drive one circle clock-wise. Correct the distance H as shown.

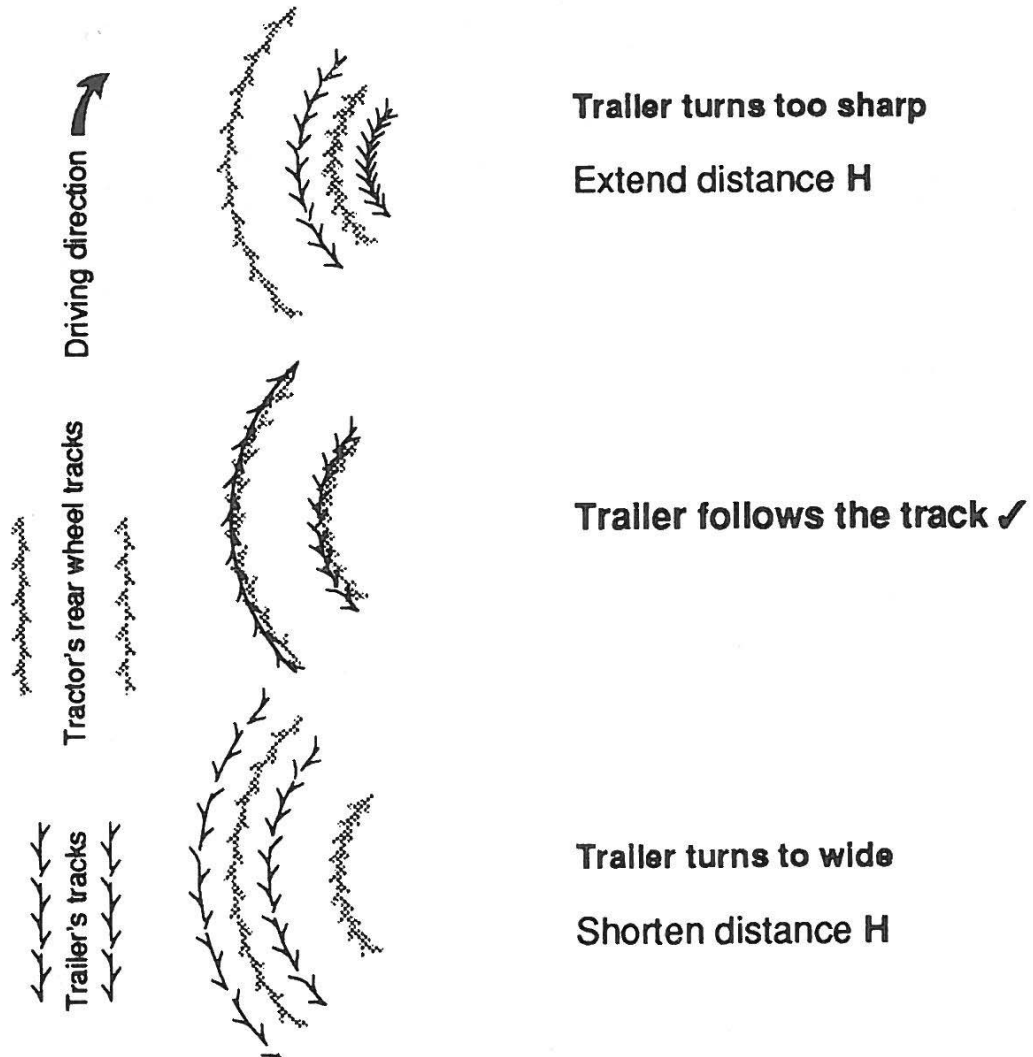

WARNING: When driving on public roads, lock the steering axle with pin 5 and remove rod 4 from the activating bracket 6, thereby making sprayer respond as a normal trailed implement.

Track correction (if fitted)

Connect the two quick couplers to a double acting outlet, and set the hydraulic ram at half extended position. When operating the sprayer along hillsides, the sprayer can be forced to follow the tractor's wheel tracks by extending or shorten the ram hydraulically.

Boogie axle (if fitted)

On TZ 3500 models equipped with boogie axles, the rear wheels will articulate up to 13° by turning with the vehicle to avoid “dozing” in the field and to reduce tyre wear.

To keep the rear wheels aligned when reversing, there are 2 single acting hydraulic rams fitted at the axle operated by a separate single acting hydraulic outlet.

To align the wheels, activate the hydraulic lever during the last 2 metres driving forward, until the wheels are aligned. Then set the lever back to neutral. Reversing is now possible.

Should a single acting outlet not be available, the rear wheels can be mechanically held in alignment by flipping the 2 locks located above the rams A forward.

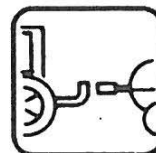
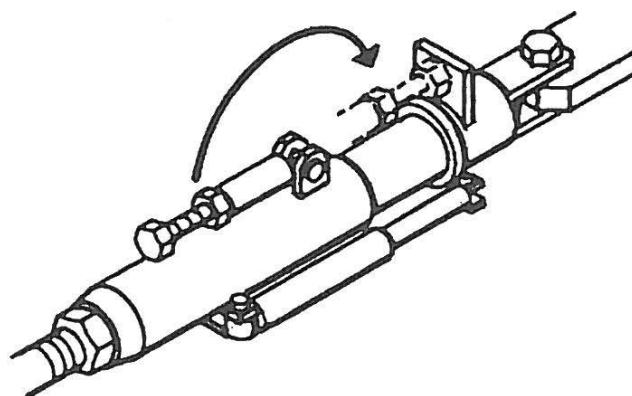
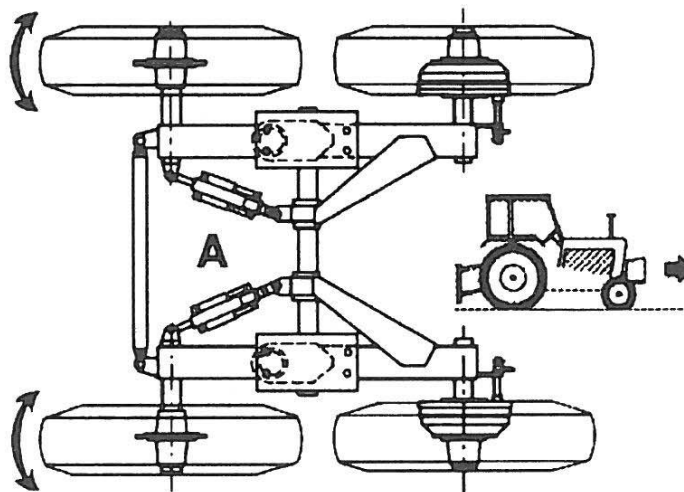

When driving forward, the hydraulic lever should be set in the “float” position or the mechanical locks flipped back to allow the rear axles to articulate again.

Roadworthiness

When driving on public roads and other areas where the highway code applies, or areas where there are special rules and regulations for marking and lights on implements, you should observe these and equip implements accordingly.



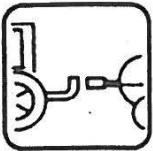

Operating instructions

Operating of the boom

WARNING: WHEN UNFOLDING THE SPRAY BOOM IT IS IMPORTANT THAT THE SPRAYER IS CONNECTED TO THE TRACTOR TO PREVENT OVERBALANCING.



BE CAUTIOUS WITH INITIAL USE OF THE HYDRAULIC SYSTEM; IF THERE IS AIR IN THE SYSTEM THIS MAY CAUSE VIOLENT MOVEMENTS OF THE BOOM. THEREFORE TAKE CARE THAT NO PERSONS OR OBJECTS ARE HURT OR DAMAGED IN THE PROCESS OF TESTING.

First set the tractor's hydraulic remote control lever in position for correct direction of oil flow. If the boom starts to rise either switch the hydraulic hoses around or set the control lever in the opposite position.

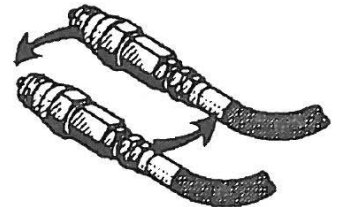

Boom manoeuvring is as follows.

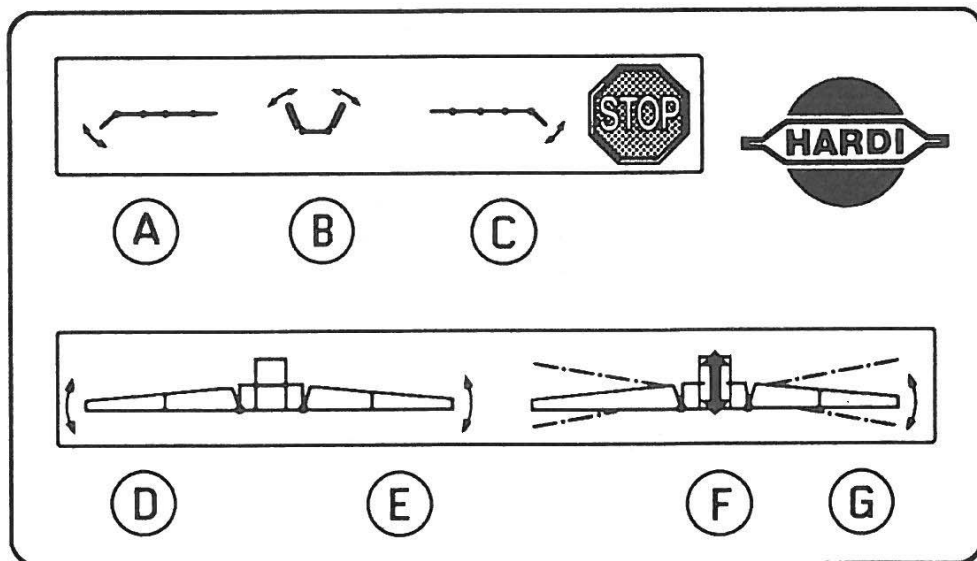

- A. Unfolding/folding of left outer section
- B. Unfolding/folding of inner section
- C. Unfolding/folding of right outer section
- D. Boom tilt for left side
- E. Boom tilt for right side
- F. Raising and lowering of boom
- G. Slanting of boom

Unfolding of boom

ENSURE THAT THE BOOMS ARE CLEAR FROM THE TRANSPORT BRACKETS BEFORE UNFOLDING.

1. Push switch **F** upwards to lift the boom clear of the rear transport brackets.
2. Push switch **D** and **E** upwards to ensure boom sections are clear of the front transport brackets.
3. Push switch **B** upwards to unfold the inner sections.
4. Push switch **A** and **C** upwards to unfold outer sections.
5. Push switch **D** and **E** down-wards to lower right and left sections.
6. Push switch **F** down-wards to lower the boom to correct height above crop- or ground level.

NOTE

The 3 upper functions, in the red rectangle with STOP sign, must only be operated when sprayer is stationary. Failure to do so will damage the boom.



Folding of boom

1. Raise boom **F** to upper position.
2. Check the slanting function is midway **G**.
3. Fold outer sections, **A** and **C**.
4. Raise right and left sections **D** and **E**.
5. Fold inner sections **B**.
6. Lower boom **F** until boom rests on rear transport brackets.
7. Lower right and left boom sections until they rest the front transport brackets **D** and **E**.

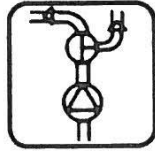

Self-cleaning filter

Operation diagram

1. From pump
2. To safety valve (operating pressure is 12 bar)
3. Double filter screen
4. Guide cone
5. To operating unit
6. Replaceable restrictor
7. Return to tank
8. Nut

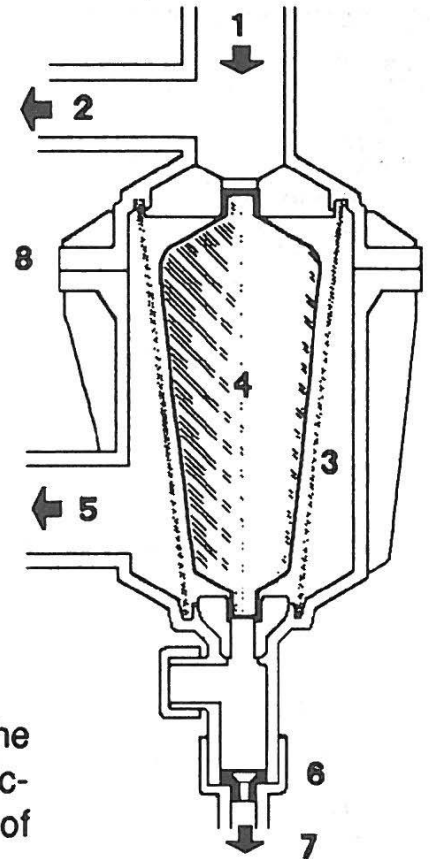

Choice of restrictor

It is important to have a large flow through the filter. This is achieved by choosing the restrictor size in relation to the liquid consumption of the spray boom.

4 restrictors are supplied. Use the green one (largest orifice A) first.

The hose N is demounted at the self-cleaning filter, the restrictor is put in the hose and the hose is mounted again.

If the required working pressure cannot be obtained, the restrictor is too large. Choose a smaller restrictor.

Start with the black one, then the white and finally the red one.

When cleaning the filter remove hose N and the hose at the safety valve, and check there are no residues.

Standard filter size is 80 mesh. Sizes of 50 and 100 mesh are available and can be changed by opening the filter top. Check the O-rings before reassembling the filter and replace if damaged.

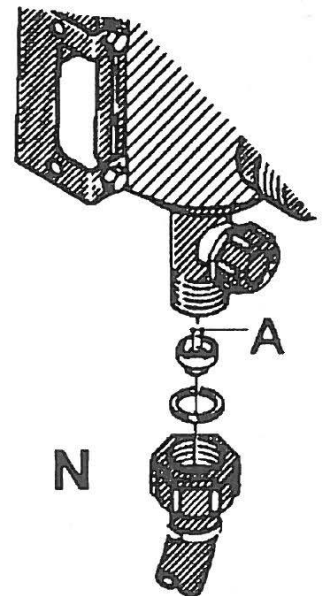

Adjustment of the controls



EC operating unit

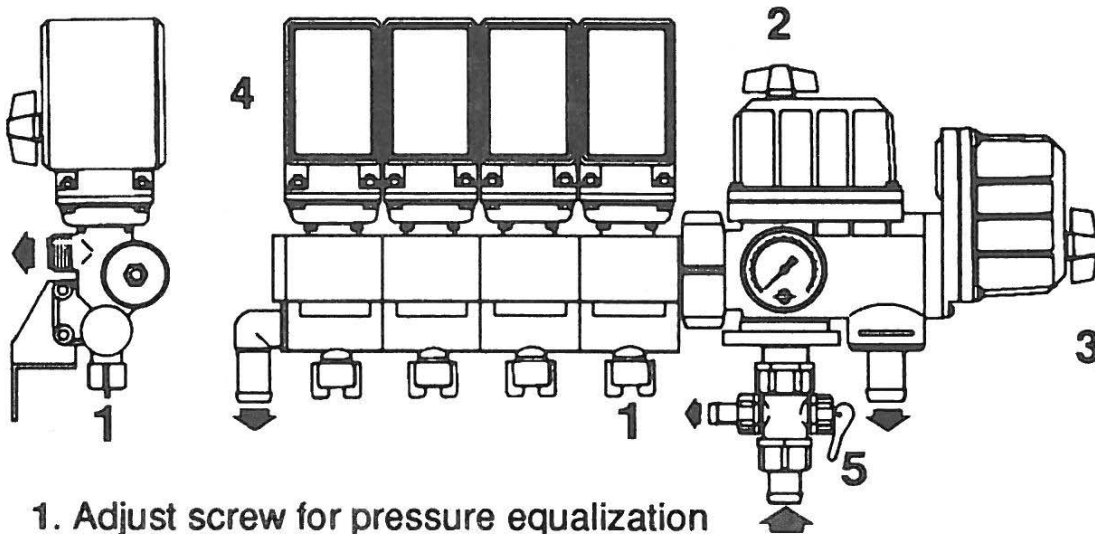

1. Adjust screw for pressure equalization
2. On/off valve
3. Pressure control valve
4. Distribution valve
5. Pressure agitation valve

EC remote control box

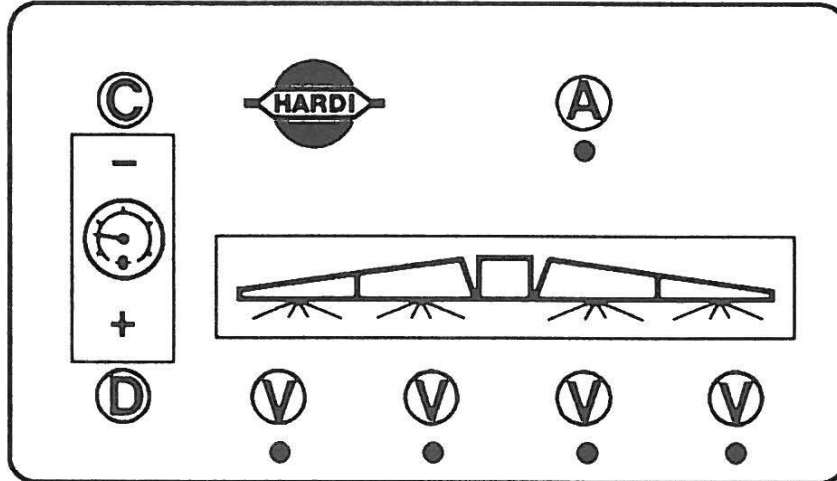

- A. Operating switch for on-off valve
- V. Operating switch for distribution valves
- C. Pressure regulation switch (to lower)
- D. Pressure regulation switch (to raise)

1. Choose the correct nozzle size by turning the triplet nozzle bodies to the suitable nozzle for the spray purpose. Make sure that all nozzles are the same type and capacity. See "Spray Technique" book.



2. Open or close lever **5** depending on whether pressure agitation is required. (Remember pressure agitation takes 5% to 10% of pump output).

3. On-off switch **A** is activated against green.

4. All distribution valves switches **V** are activated against green.

5. Pressure regulation switch **C** is activated until emergency handle **3**, stops rotating (minimum pressure).

6. Put the tractor in neutral and adjust the P.T.O. and thereby the number of revolutions of the pump corresponding to the intended travelling speed.

Remember the number of revolutions on the P.T.O. must be kept between 300-600 r/min.

7. Pressure regulation switch **D** is activated till the recommended pressure is shown on the pressure gauge.

ADJUSTMENT OF PRESSURE EQUALIZATION:

8. Close the first distribution valve switch **V**.

9. Turn the adjusting screw **1** until the pressure gauge again shows the same pressure.

10. Adjust the other sections of the distribution valve in the same way.

NOTE: HEREAFTER ADJUSTMENT OF PRESSURE EQUALIZATION WILL ONLY BE NEEDED IF YOU CHANGE TO NOZZLES WITH OTHER CAPACITIES.

11. Operating the control unit while driving:

In order to close the entire boom switch on-off **A** to off position. This returns the pump output to the tank through the return system. The diaphragm anti-drip valves ensure instantaneous closing of all nozzles.

In order to close one or more sections of the boom, switch the relevant distribution valve **V** to off position. The pressure equalization ensures that the pressure does not rise in the sections which are to remain open.

In case of power failure it is still possible to activate all functions of the

operating unit. To operate manually, disconnect the multiplug first.

When the sprayer is put aside, the control box and the multiplug must be protected against moisture and dirt. A plastic bag may be used to protect the multi plug.



Operation of the tank drain valve

Pull the string at left hand side of the tank to open the drain valve. The valve is spring-loaded, but can be kept open by pulling the string out-and upwards in the V-shaped slit.

To release and close the drain valve again, pull the string down-wards and the valve will close automatically.

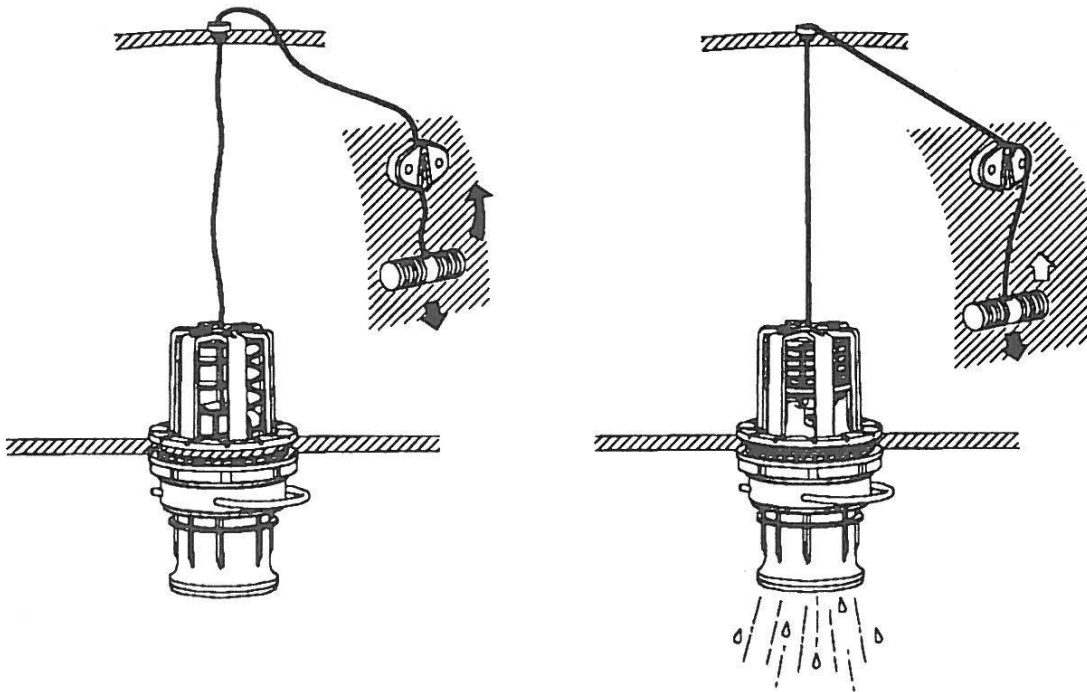

If draining residues, e.g. liquid fertilizers into a reservoir, a snap-coupler with hose can rapidly be connected to the drain valve, and the liquid safely drained.

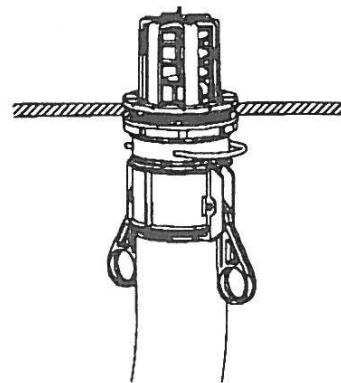



Spray Technique - see separate book.



Maintenance

In order to derive full benefit from the sprayer for many years the following few but important rules should be kept:



Cleaning the Sprayer - see separate book.

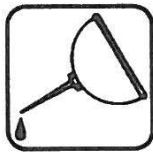

Lubrication

Recommended lubrication is shown in following tables.
Use ball bearing grease (lithium grease No.2).



NOTE: If the sprayer is cleaned with a high pressure cleaner or fertilizer has been used, we recommend lubrication of all sections.

POS.

○ — 7 Position on sprayer



Operation hours



Oil



Page to find more information









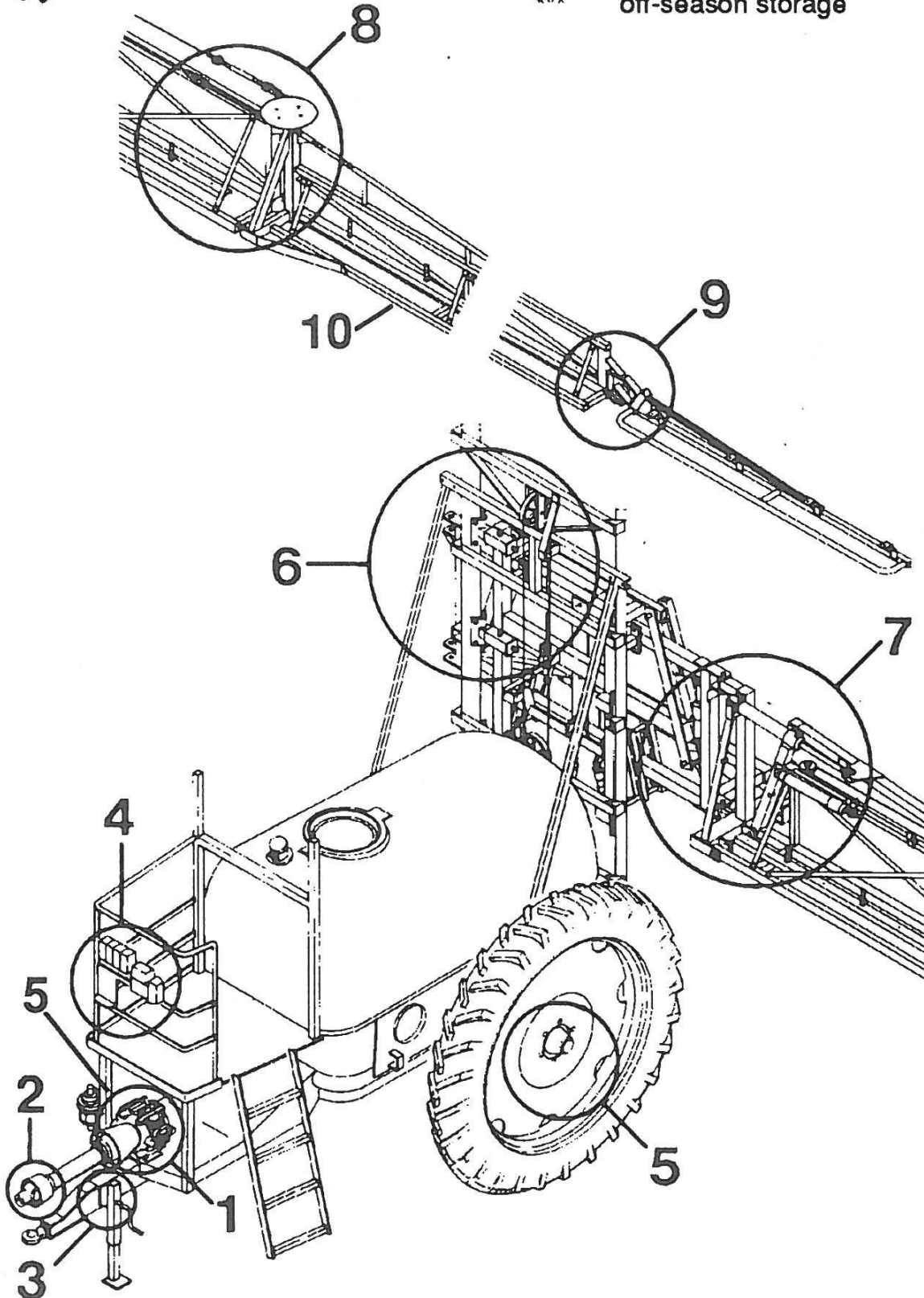

Grease



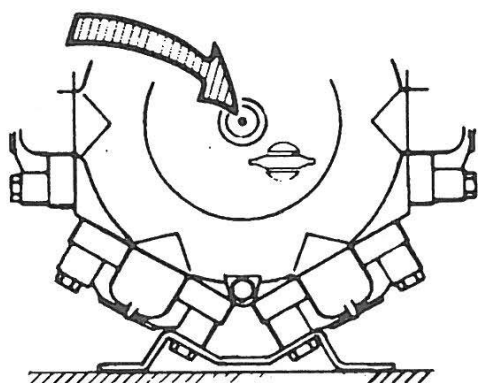
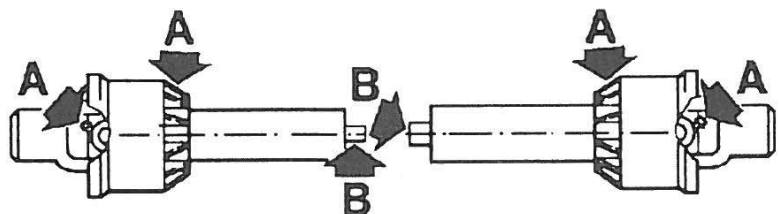
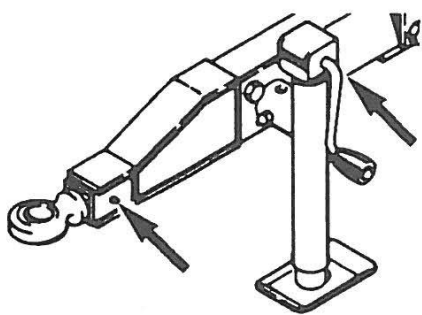
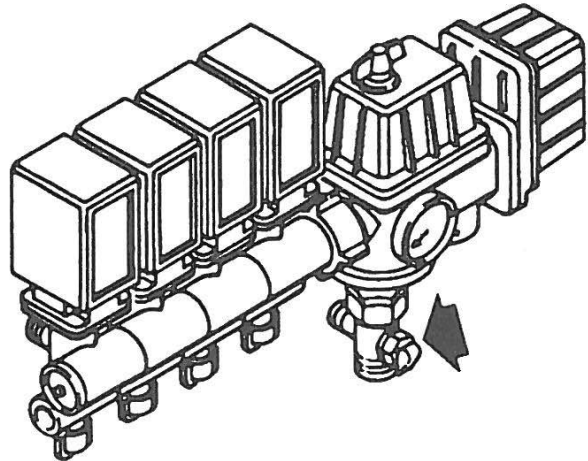



Winter protection or off-season storage

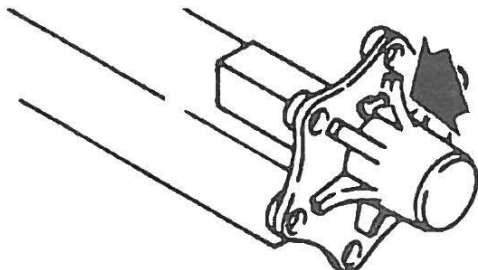
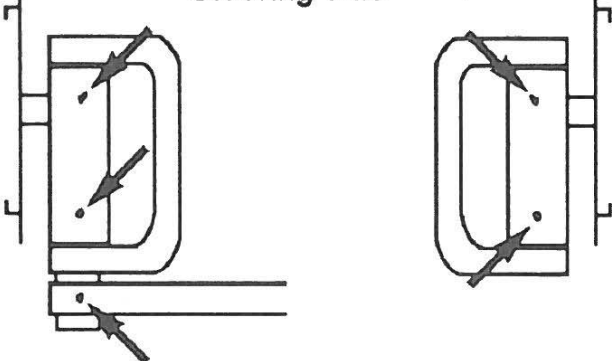
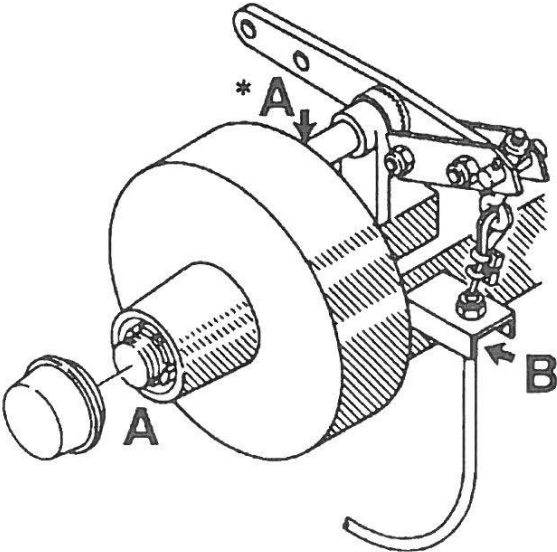
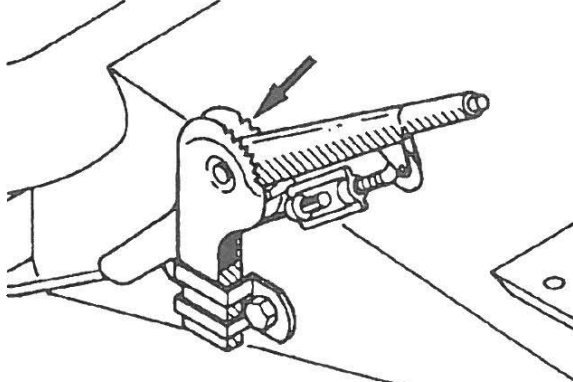

POS.					
1		X	40		34
2 A B		X X	12 40		8 9
3		X	40		4
4	X		40		6 15 35 36

POS.					
5		X	1000		5 31
5		X	1000	<p data-bbox="798 627 1005 672">Steering axle</p> 	9 10
5 A B	X	X	1000 100		5 31 32 33
*A		first thereafter	100 1000		7 32

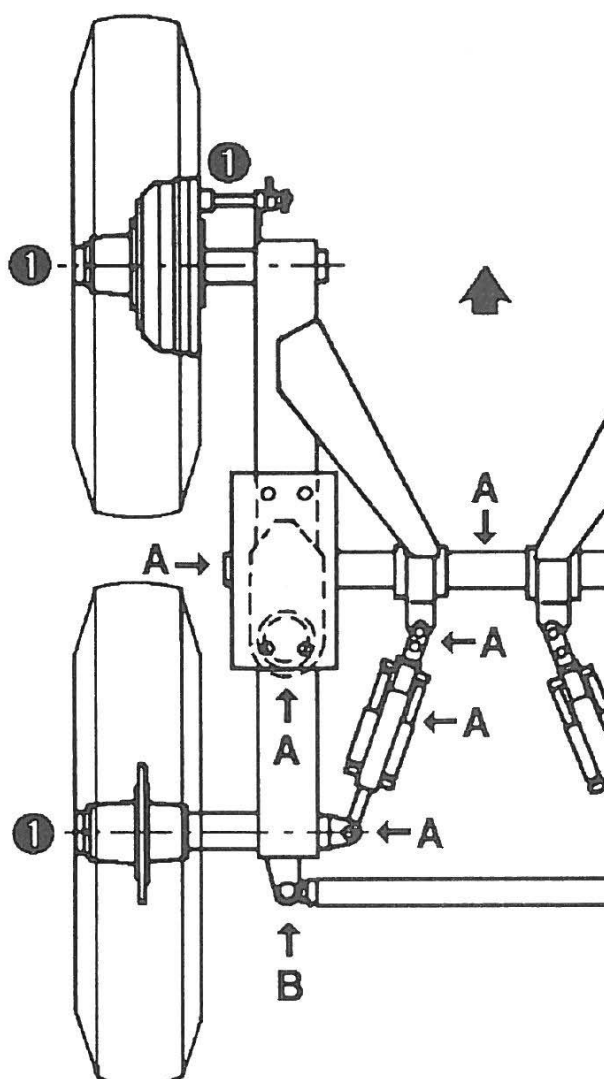
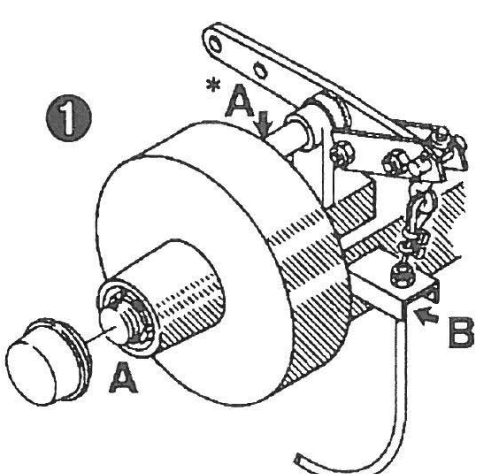
POS.					
5 A B	X	X	1000 1000	 <p>The drawing shows a mechanical assembly with a central vertical shaft. At the top, there is a component labeled '1'. Below it, a horizontal arm extends to the right, with a downward arrow labeled 'A'. Further down, another horizontal arm extends to the left, with a rightward arrow labeled 'A'. Below that, a vertical shaft has an upward arrow labeled 'A'. At the bottom, a horizontal shaft has a leftward arrow labeled 'A' and a vertical shaft has an upward arrow labeled 'B'. A large upward-pointing arrow is also present on the right side of the assembly.</p>	5 11 31
5 A B *A	X	X first thereafter	1000 100 100 1000	 <p>The drawing shows a mechanical assembly with a large cylindrical component. A callout '1' points to a small component on the left. A callout '*A' points to a component on the top right. A callout 'A' points to a component on the bottom left. A callout 'B' points to a component on the bottom right.</p>	

POS.



6
A
B





X

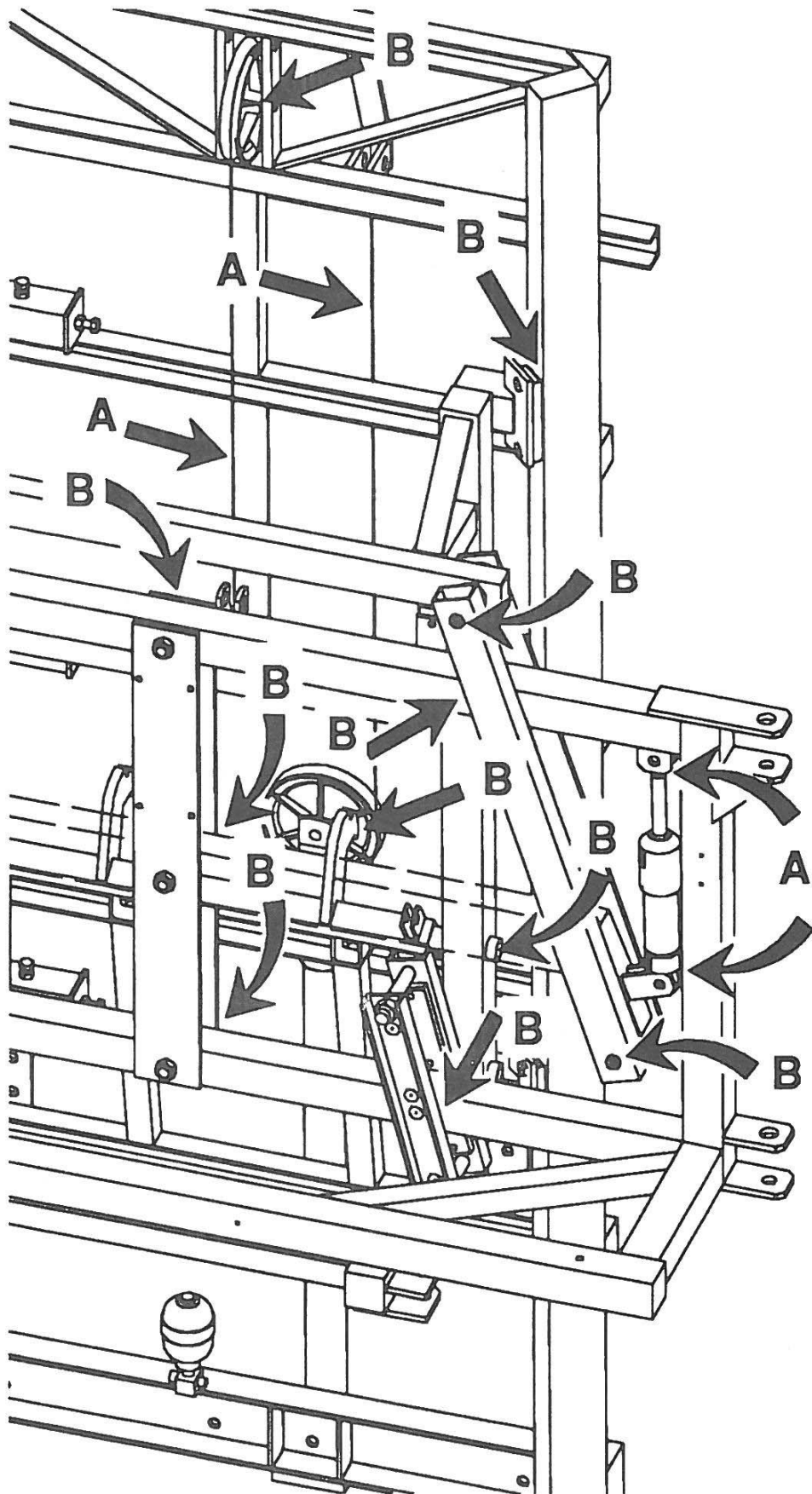



X

40
40

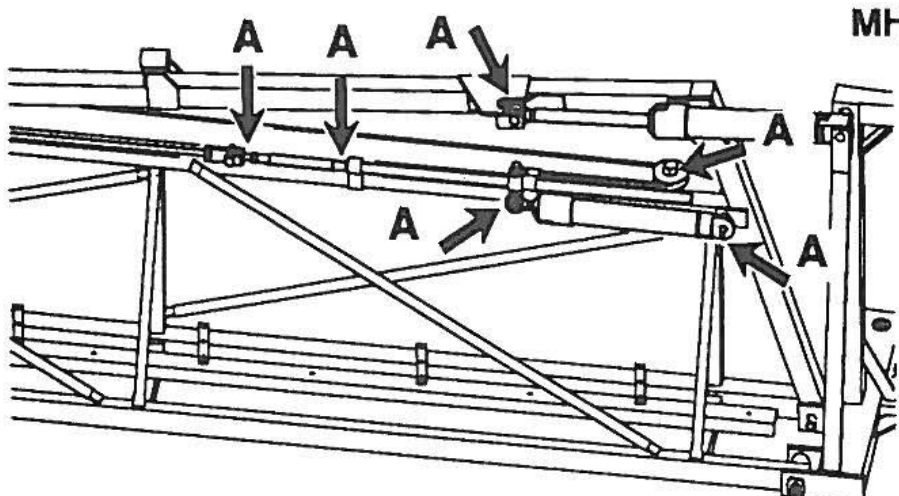
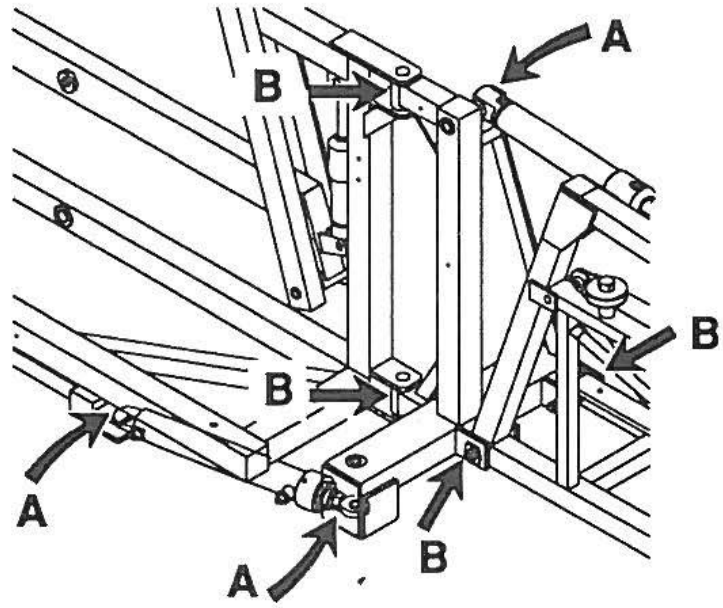
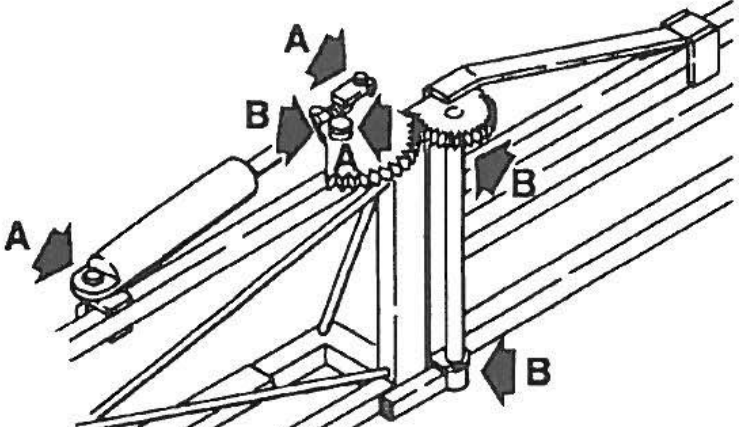

26
27

POS.					
7 A	X		40		29
8 A B	X	X	40 40		29
8 A B	X	X	40 40		28

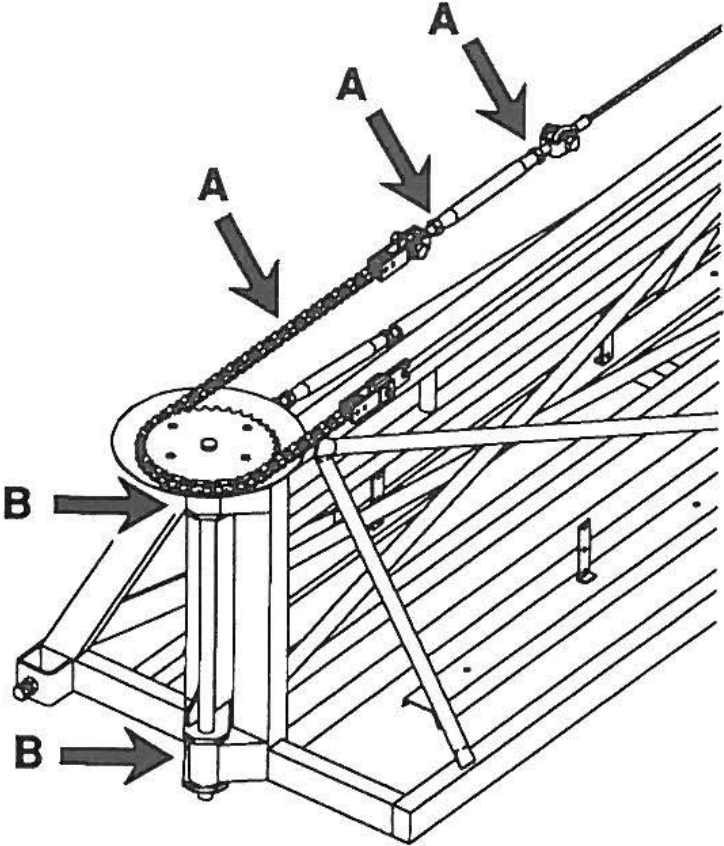
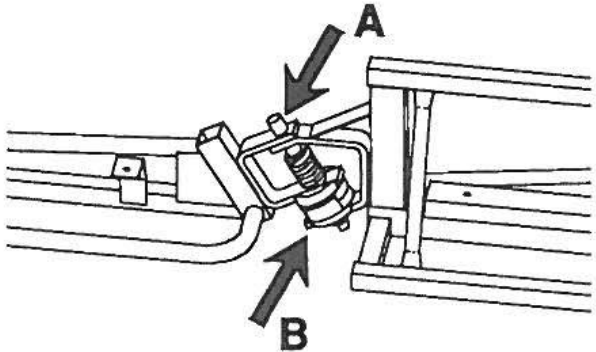
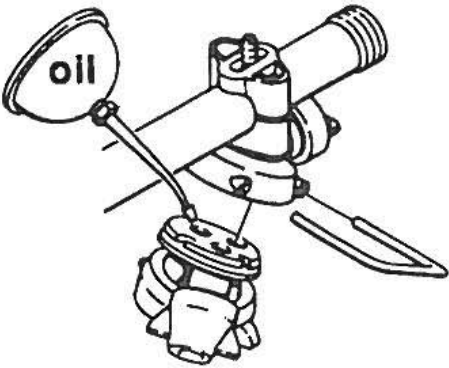
POS.					
8 A B	X	X	40 40	 <p style="text-align: right;">MHZ</p>	28 29
9 A B	X	X	40 40		30
10	X		80		36



Re-adjustment of the boom

After having used the sprayer for some days the boom should be adjusted according to the following instructions:

When adjusting the boom and the trapeze the spray boom must be in the working position. Tractor and sprayer must be on level ground.



WARNING

NOBODY MUST STAND UNDER THE BOOM WHILST ADJUSTMENT IS TAKING PLACE.

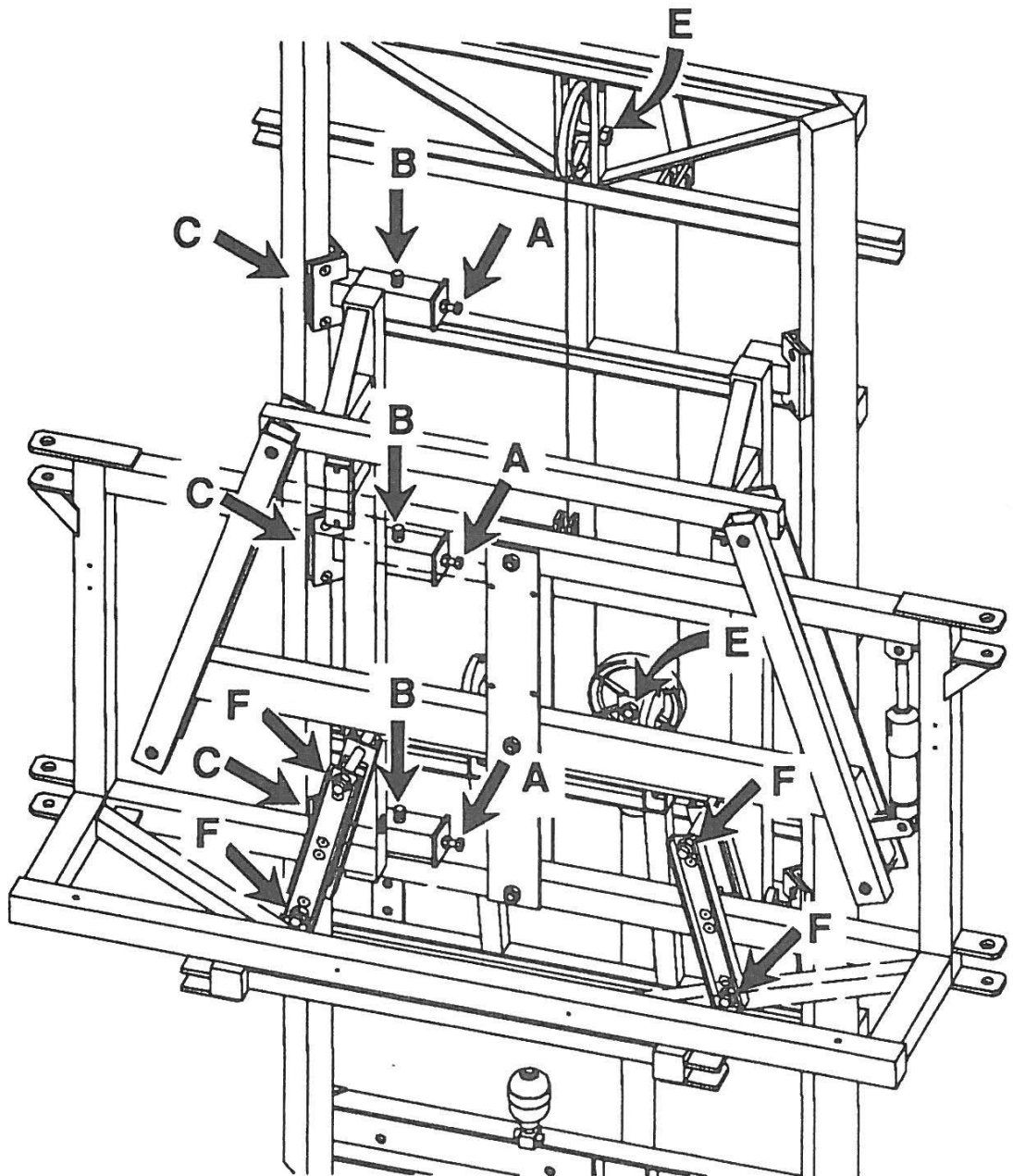



1. Boom lift.

The boom lift should be adjusted so the boom can freely move up and down when the lift cylinder is actuated.

Adjust the screws **A** so the glide pads **C** are just touching at all points in both directions. Tighten the screws **B**, and counter nuts after adjustment. The lift should move freely but without any play between lift and gantry **C**.

The cable connecting the hydraulic ram and the boom lift should be inspected regularly for wear or damage. If individual threads in the cable start breaking, the cable must be replaced immediately.

CAUTION! When detaching and attaching the steel cable, it is important that the hydraulic activated transport support claw is fully engaged. Secure the claw with a pin or bolt **D** to prevent it from disengaging during replacement of cable.

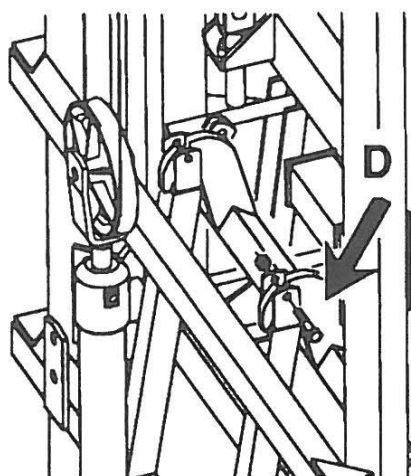

The bolts **E** at the pulleys must be retightened regularly.

The cable should be well lubricated with special **steel cable lubricant** to prevent corrosion and excessive wear (see section "Lubrication").

2. Trapeze suspension.

For the trapeze to function it must not be overtight. If it is too loose the boom will yaw (forward and back movement). This results in a poor spray distribution.

Adjustment is made after having lubricated all pivot points (see section "Lubrication").

Adjust trapeze bolts **F** so that the trapeze is not too tight nor too loose. Minor adjustment in the field may be necessary.



NOTE: The following adjustments are best done without pressure in the hydraulic rams.

3. Adjustment of outer sections (12-18 m LHZ models)

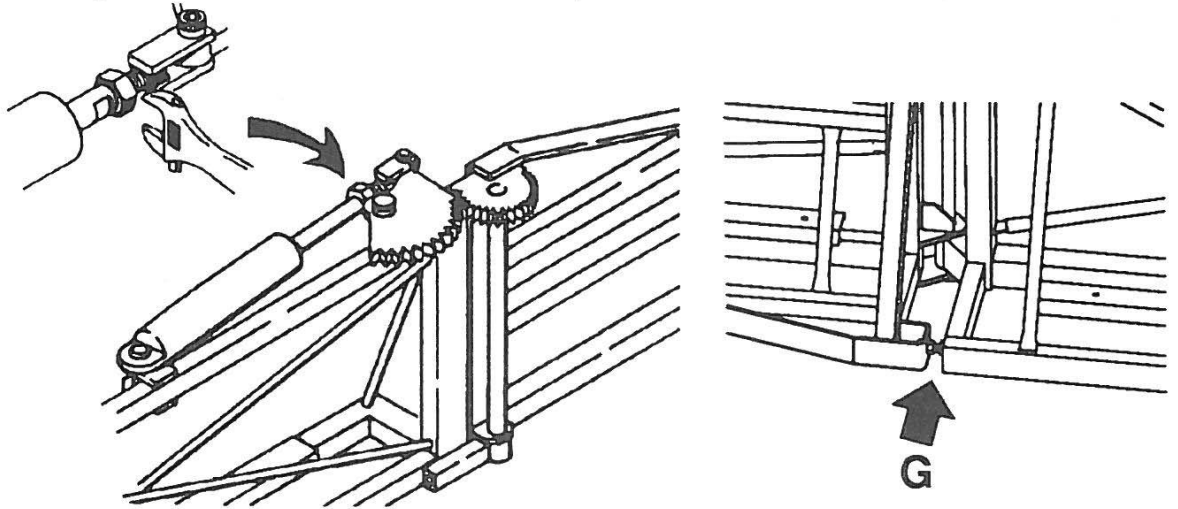

1. Fold the outer sections completely and adjust the folding ram, so the outer section folds firm, but not hard, against the stop bracket on the inner section. Don't forget the counter nut.
2. Unfold the outer sections completely. The boom should unfold, so the inner and outer sections at G are touching firmly, and the boom is steady.

4. Adjustment of outer sections (20-28 m MHZ models)

1. Unfold the outer section completely, until it touches the stop bolt G.
2. Adjust the stop bolt G, so the inner and outer section are aligned. Tighten the counter nut.
3. Adjust the rigging screw H, until the outer section is lying firmly against the stop bolt, and is steady, when pulling backwards on the outer section.
4. Fold the outer sections completely.
5. Adjust the other rigging screw J, until the outer section is lying firmly against the inner section rubber stop.

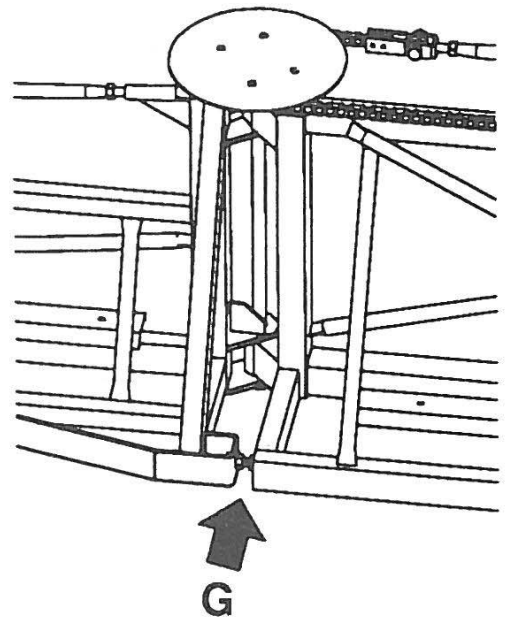

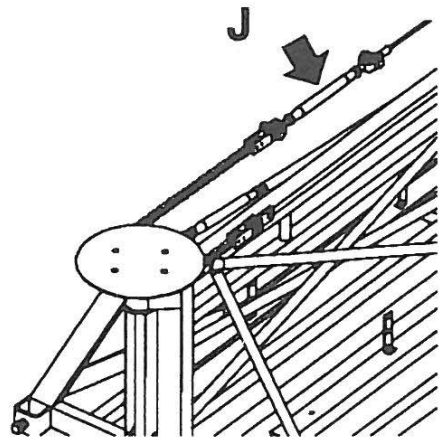
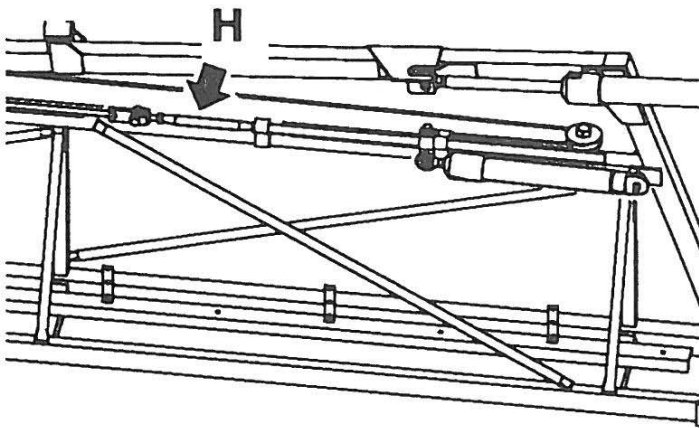

5. Adjustment of Inner sections (all models)

1. Fold the outer sections first, then the inner sections, until the folding rams are at full length, and place the boom in the transport brackets. Adjust the ram and eye-joint at K until the boom is about to touch the outer stop at the transport brackets L.
2. Then adjust the inner stop M at the transport bracket, so it touches the boom. Stop M should not cause the boom to bind.

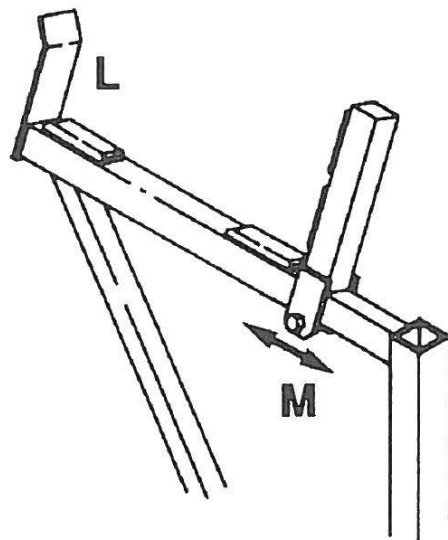
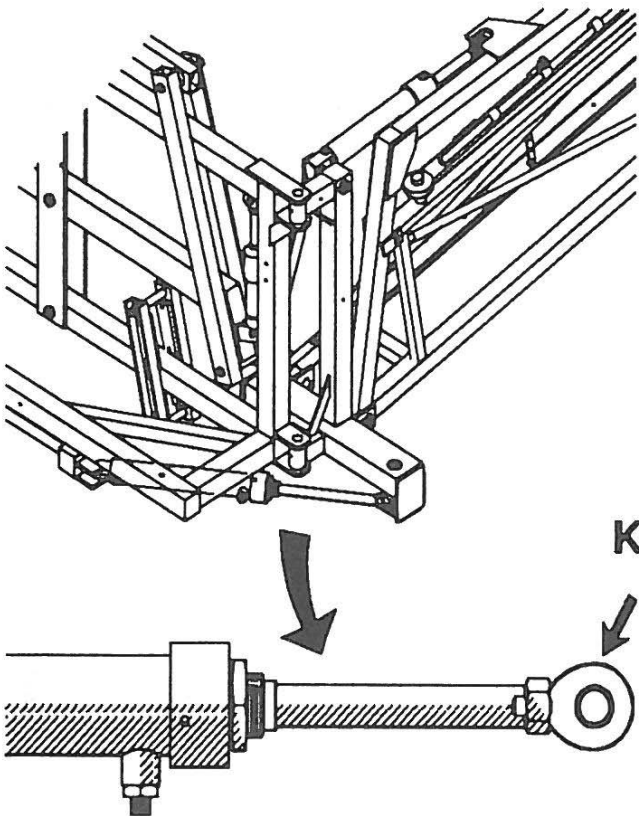



3. Unfold the boom again, slacken counter nut **N** and adjust the inner stop **O** at the ram until the booms are in right angle to the tank frame. Retighten counter nut **N**.

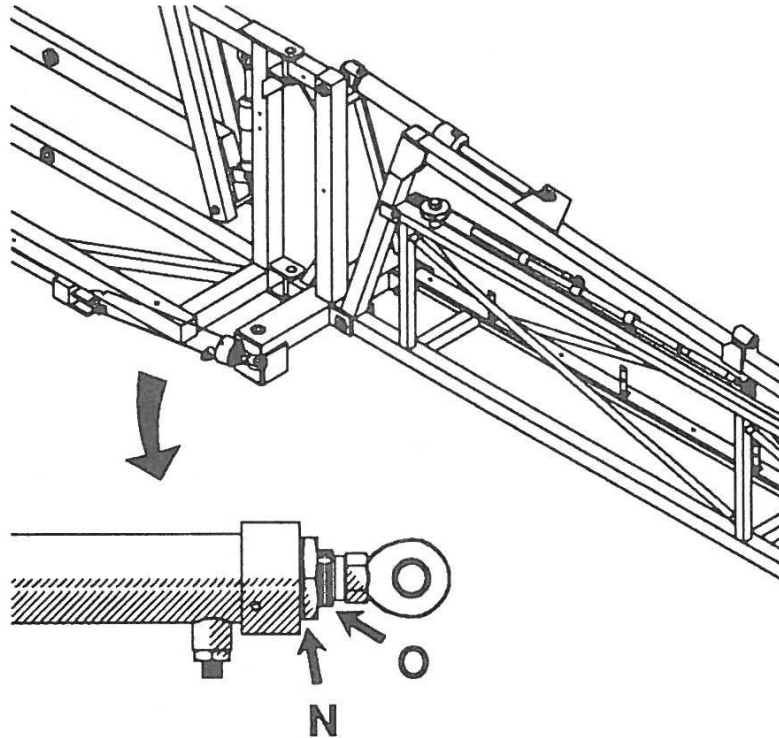

6. Break-away.

The function of the breakaway is to prevent or reduce boom damage should it strike an object or the ground. The break-away can not be adjusted but must be regularly greased (see section "Lubrication").

REMEMBER TO TIGHTEN ALL COUNTER NUTS AGAIN AFTER ADJUSTMENT.



Recommended tyre pressure

The tyres should not run under-inflated. This only promotes instability and rapid wear.

Tyre size:	Maximum pressure:
9,5 x 32"	3,5 bar (50 psi)
9,5 x 36"	3,8 bar (54 psi)
9,5 x 44"	3,0 bar (43 psi)
9,5 x 48"	3,0 bar (43 psi)
11,2 x 44"	3,0 bar (43 psi)
12,4 x 46"	3,0 bar (43 psi)

The pressure is specified for a full loaded trailer. When travelling on hard road surfaces with maximum load, do not exceed 10 km/hr. Remember it is easier to let off a little pressure for a specific use than to re-inflate a tyre in mid-field.



Wheel nuts and bearings

Check wheel nut tension after the first 8 working hours, hereafter every 50 hours.



	Thread	Spanner size (mm)	Torque (Nm)
Without brakes	M18 x 2,5	24	300
	M20 x 1,5	27	400
With brakes	M18 x 1,5	24	260
	M20 x 1,5	27	340
	M22 x 2,0	32	420

For rims with lugs, the lug bolts should be tightened to a torque of 250 Nm.

Check roller bearing slack after the first 8 hours and 50 hours. Thereafter every 100 hours.

If necessary, adjust as follows

1. Jack wheel up. It is best to remove the wheel.
2. Remove hub cap **A** and split pin **B**.
3. Shaft nut **C** is tightened until slight rotation resistance of drum is noted (check it is not the brake linings).
4. Now loosen shaft nut until first split pin hole is visible.
5. Insert split pin and replace hub cap.

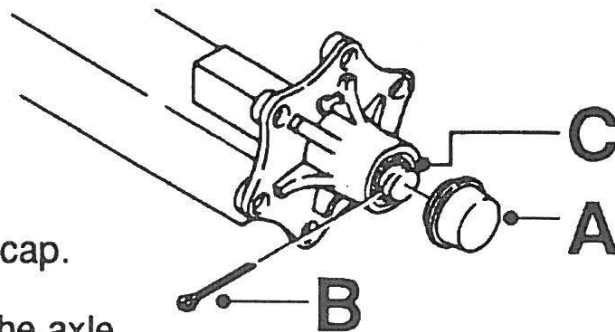

After 1000 hours or once a year, the axle bearings are greased.



Adjustment of brakes

As the brake linings wear it may be necessary to adjust the position of the brake arm. Initial check is made at 100 hours.

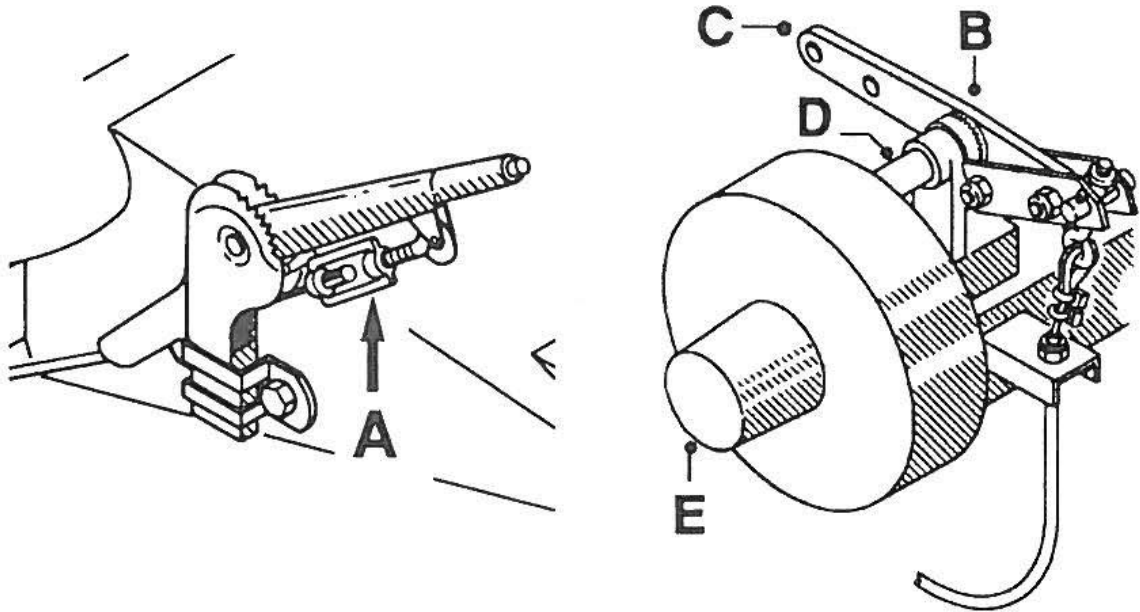

1. Slacken the hand brake cable **A**.
2. Loosen nut **B** holding brake arm **C** to cam shaft **D** entering brake drum.
3. Loosen brake arm **C** so the grooved washers are freed.
4. Rotate cam shaft **D** as if braking (use a pipe wrench) until wheel just turns smoothly.
5. Refit brake arm **C** and nut.
6. Take slack from hand brake cable **A**.

Cam shaft **D** is to be greased after the initial 100 hours and thereafter 1000 hours or once a year.

After 1000 hours or once a year, the axle bearings are greased and brake linings checked. Remove hub cap **E** to grease bearings. The brake drum must be removed before the linings can be checked. Replacement must take place before the brake lining rivets contact the brake drums.



CAUTION! When inspecting and servicing brakes, avoid inhaling the brake dust, as it can cause major health injuries. Use a respirator. Rinse brakes with water instead of using compressed air.

Maintenance of pneumatic brakes.

Daily:

- Check brake system for proper function.
- Drain air reservoir for water at bottom drain valve

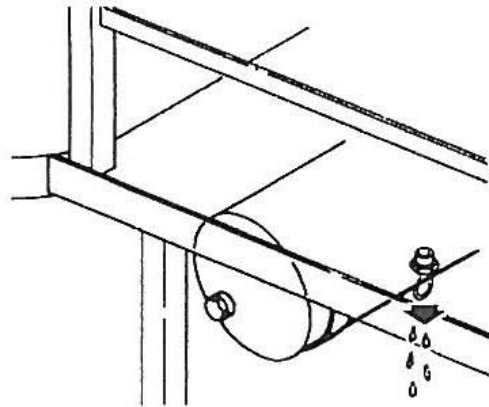

Weekly:

- Fill air reservoirs.
- Stop motor.
- Apply brake and check system for leaks.
- If more than 1/2 piston displacement is used, the brake linings must be adjusted (see section "Adjustment of brakes").
- Check the protection bellows for leaks and proper attachment.

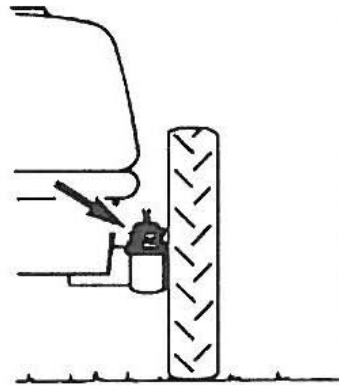

Filters

Clean filters ensure;

- Sprayer components such as valves, diaphragms and operating unit are not hindered or damaged during operation.
- Nozzle blockages do not occur whilst spraying.
- Long life of pump. A blocked suction filter will result in pump cavitation.

The main filter protecting sprayer components is the suction filter at the top of the tank. Check it regularly. Ensure the O-ring on filter housing is in good condition and lubricated.

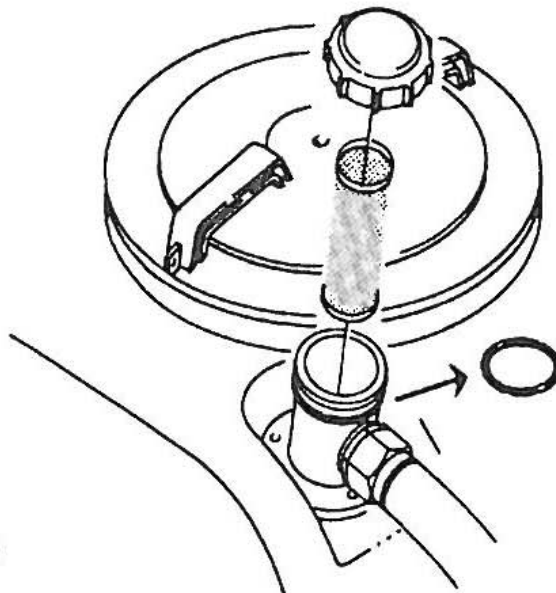



Changing of valves and diaphragms

Valves

Remove valve cover 1. Before changing the valves 2 note the orientation of the valves so that they are replaced correctly.

Important: Note valve with red flap 2A is placed in the valve opening shown.

It is recommended to use new O-rings 3 when changing or checking the valves.

Diaphragms

Remove the diaphragm bolt 4 after having dismantled the valve cover as indicated above. The diaphragm 5 may then be changed. If fluids have reached the crankcase, re-grease the pump thoroughly.

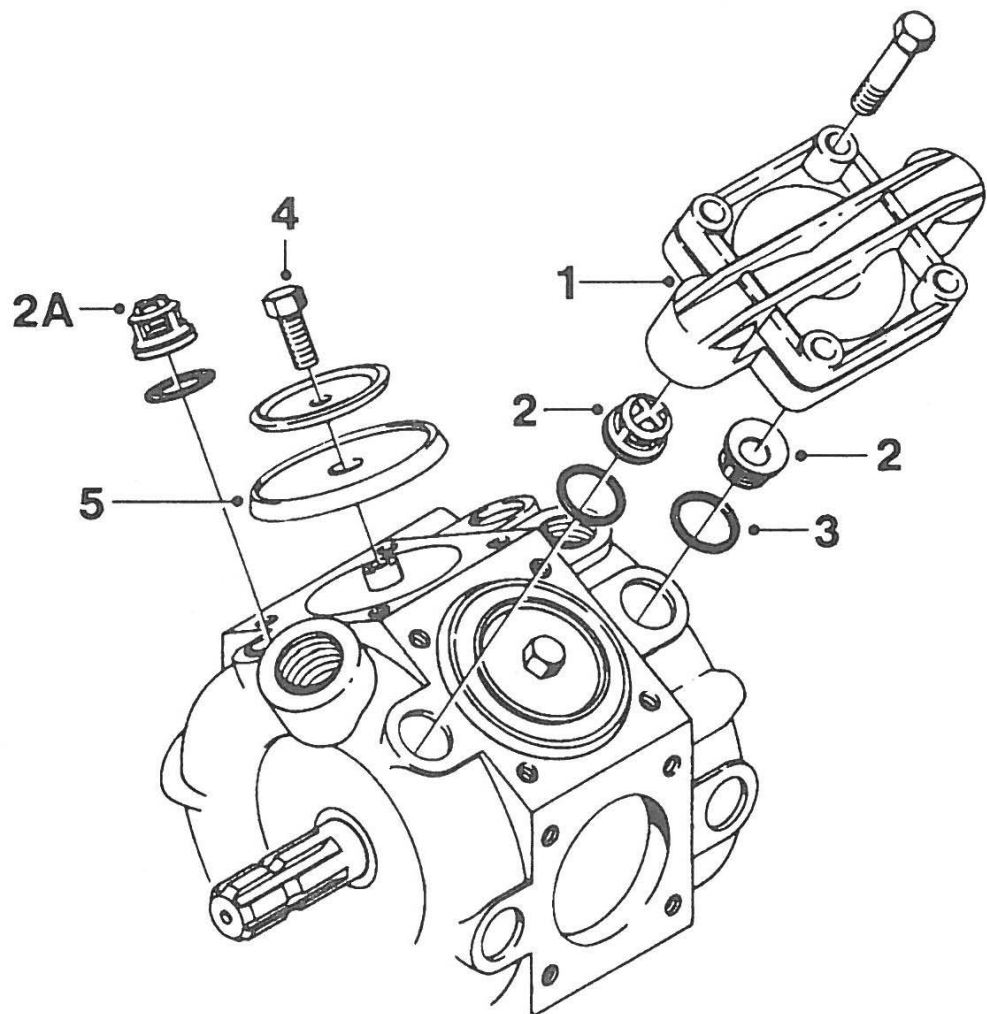

Level indicator

The level indicator reading should be checked regularly.

When the tank is empty, the floater should rest on the stop pin on the rod and the O-ring at the indicator should be positioned at the top position line A.

If any deviation is found, pull out the plug B, and loosen the screws C, and adjust the length of the cord.

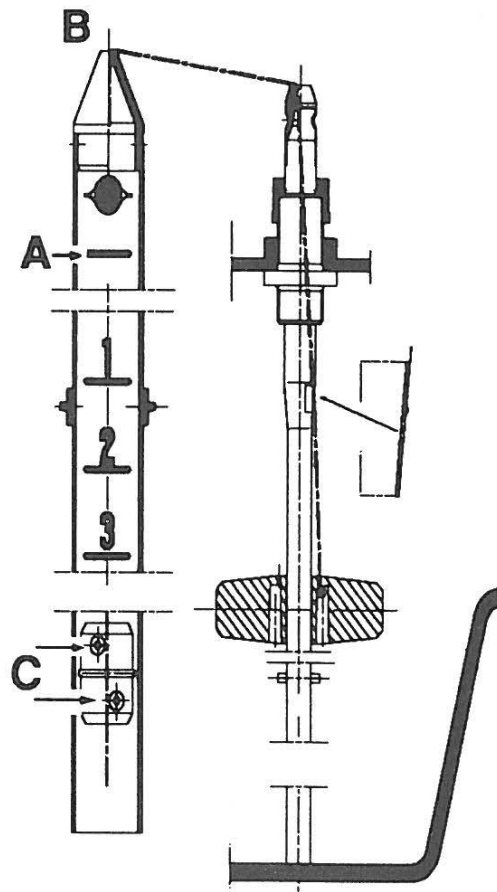

Changing of ball seat in operating unit

If problems with on/off valve occurs (dripping nozzles when on/off valve is closed), the ball and ball seat should be checked.

Remove the 2 bolts fixing the on/off-pressure valve unit to the bracket, unscrew the union nut A and pull the on/off-pressure valve away from the distribution valves.

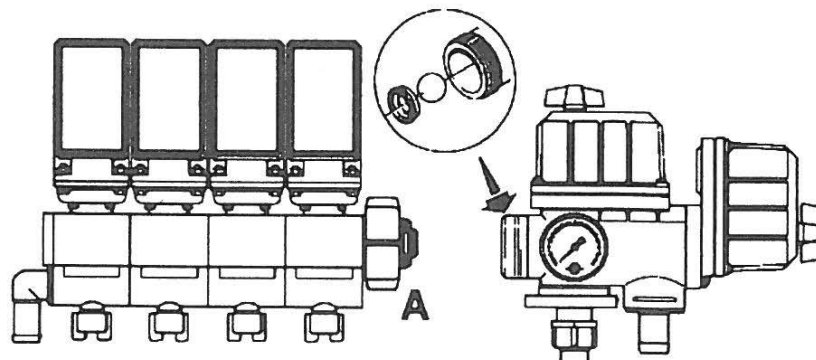

Check the ball for sharp edges and scratches and check the ball seat for cracks and wear - replace if necessary.





Check of valve cone in distribution valves

Periodically check the distribution valves for proper sealing.

Run the sprayer with clean water and open on/off and all distribution valves.

Remove the clip **A** and remove hose **B** for the constant pressure device. When the housing is drained, there should not flow liquid through the constant pressure device. If there is any leakage, the valve cone **E** must be changed.

Remove the clip **C**, and pull the EC-motor off the valve housing.

Then unscrew the screw **D** and replace the valve cone **E**. Reassemble in opposite sequence.

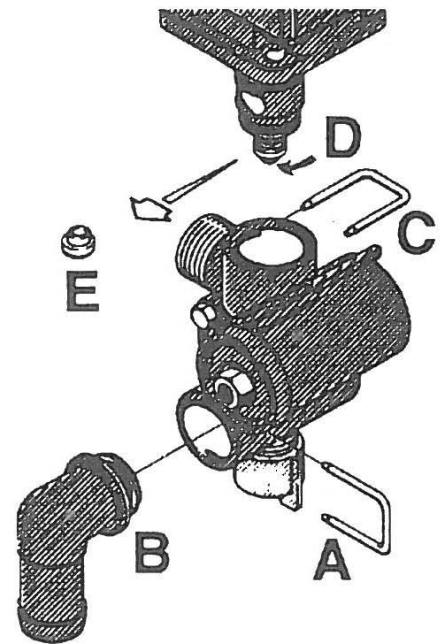

Nozzle tubes and fittings

Poor seals are usually caused by;

- missing O-rings or gaskets
- damaged or incorrectly seated O-rings
- dry or deformed O-rings or gaskets
- foreign bodies

Therefore, in case of leaks: **DO NOT** over-tighten. Disassemble, check condition and position of O-ring or gasket, clean lubricate and reassemble.

For **radial** connections only hand tighten them.

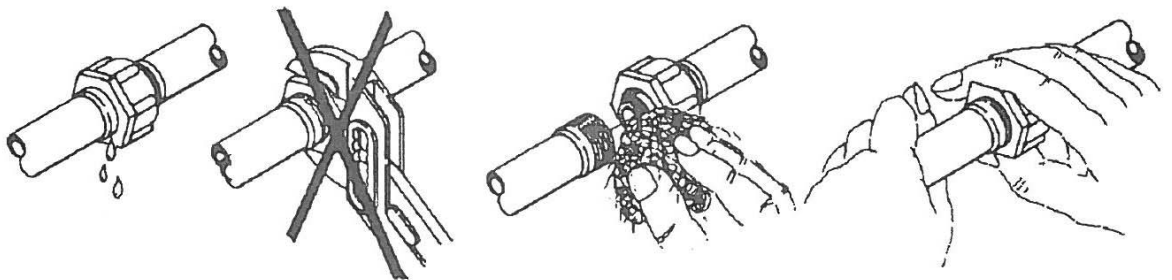
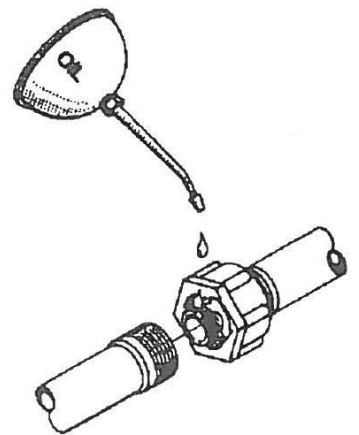

The O-ring to be lubricated **ALL THE WAY ROUND** before fitting on to the nozzle tube.

For axial connections, a little mechanical leverage may be used.



Off-season storage

When the spraying season is over you should devote some extra time to the sprayer before it is stored.

Hoses

Check that none of the hoses are caught or have sharp bends.

A leaky hose can give an annoying delay in the middle of the spraying job. Therefore check all the hoses and change if there is any doubt about the durability.

Paint

Some chemicals are very hard on paints. It is therefore well advised to remove rust, if any, and then touch up the paint.

Tank

Check that no chemical residues are left from the last spraying. Chemical residues must not be left in the tank for a long time. It will reduce the life of the tank. See "Spray Technique" book - Cleaning the sprayer.

Operating unit

When the sprayer is put away the control box and the multiplug must be protected against moisture and dirt. Possibly use a plastic bag.

Transmission shaft

Check that the transmission shaft fulfills its security purpose, e.g. that shields and protective tubes are intact.

Anti-freeze precaution

If the sprayer is not stored in a frost-proof place you should take the following precautions: Put at least 10 litres of 33% anti-freeze mixture in the tank and let the pump run a few minutes so that the entire system including spray hose are filled. Remove the glycerine filled pressure gauge and store it frost free in vertical position.

The anti-freeze solution also hinders the O-rings and gaskets from drying out.



Operational problems

In cases where breakdowns have occurred the same factors always seem to come into play:

- Minor leaks on the suction side of the pump will reduce the pump capacity or stop the suction completely.
- A clogged suction filter will hinder or prevent suction so that the pump does not operate satisfactorily.
- Clogged up pressure filters will result in increasing pressure at the pressure gauge but lower pressure at the nozzles.
- Foreign bodies stuck in the pump valves with the result that these cannot close tightly against the valve seat. This reduces pump efficiency.
- Poorly reassembled pumps, especially diaphragm covers will allow the pump to suck air resulting in reduced or no capacity.
- Electrical and hydraulic components that are contaminated with dirt result in poor connections and rapid wear to the hydraulic system.

Therefore ALWAYS check:

1. Suction, self-cleaning, pressure and nozzle filters are clean.
2. Hoses for leaks and cracks, paying particular attention to suction hoses.
3. Gaskets and O-rings are present and in good condition.
4. Pressure gauge is in good working order. Correct dosage depends on it.
5. Operating unit functions properly. Use clean water to check.
6. Electrical and hydraulic components are maintained clean.

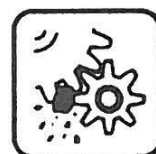

Fault	Probable cause	Control / remedy
Liquid system		
No spray from boom when turned on.	Air leak on suction.	Check if red suction lid/O-ring are sealing.
		Check suction tube and fittings.
		Check tightness of pump diaphragm and valve covers.
	Air in system.	Fill suction hose with water for initial prime.
Lack of pressure.	Incorrect assembly.	Agitation nozzles not fitted.
		Restrictor nozzle in self-cleaning filter not fitted.
		Safety valve spring for self-cleaning filter not tight.
		Too little distance between yellow suction pipe and tank bottom.
	Pump valves blocked or worn.	Check for obstructions and wear.
Defect pressure gauge.	Check for dirt at inlet of gauge.	
Pressure dropping.	Filters clogging.	Clean all filters. Fill with cleaner water.
		If using powders, make sure agitation is on.
	Nozzles worn.	Check flow rate and replace nozzles if it exceeds 10%.
	Tank is airtight.	Check vent is clear.
Sucking air towards end of tank load.		Excessive agitation, turn off.
		Returns inside tank need relocation.



Fault	Probable cause	Control / remedy
Pressure increasing	Pressure filters beginning to clog.	Clean all filters.
	Agitation nozzles clogged.	Check by turning agitation off/on.
Formation of foam.	Air is being sucked into system.	Check tightness / gaskets / O-rings of all fittings on suction side.
	Excessive liquid agitation.	Turn agitation off. Reduce pump r/min.
		Check safety valve for self-cleaning filter is tight.
		Ensure returns inside tank are present.
		Use foam damping additive.
Liquid leaks from bottom of pump.	Damaged diaphragm.	Replace. See Changing of valves and diaphragms.
Operating unit		
EC operating unit not functioning .	Blown fuse(s).	Check mechanical function of microswitches. Use cleaning/ lubricating agent if the switch does not operate freely.
		Check motor. 450-500 milli-Amperes max. Change motor, if over.
	Wrong polarity.	Brown - pos. (+). Blue - neg. (-).
	Valves not closing properly.	Check valve seals for obstructions.
Check microswitch plate position. Loosen screws holding plate a 1/2 turn.		
No power.	Wrong polarity. Check that brown is pos. (+), Blue is neg. (-).	Check print plate for dry solders or loose connections.
		Check fuse holders are tight around fuse.



Fault	Probable cause	Control / remedy
Hydraulic system		
Hydraulic movements of boom are fast/slow/eradic.	Air in system.	Loosen cylinder connections and activate hydraulics until oil flow has no air in it (not whitish).
	Insufficient hydraulic pressure.	Check output pressure of tractor hydraulics. Minimum for sprayer is 130 bar.
	Insufficient amount of oil in tractor reservoir.	Check and top up if needed.
Particular cylinder not functioning.	Restrictor blocked.	Place boom in transport bracket. Dismantle and clean

Emergency operation of EC

In case of power failure it is possible to emergency activate all functions of the operating unit manually. First disconnect the multiplug from the control box. Now manually turn the emergency control knobs. The problem may be due to a blown fuse. The fuses are placed in the control box and are marked according to functions. (7 and 8 are spare fuses).

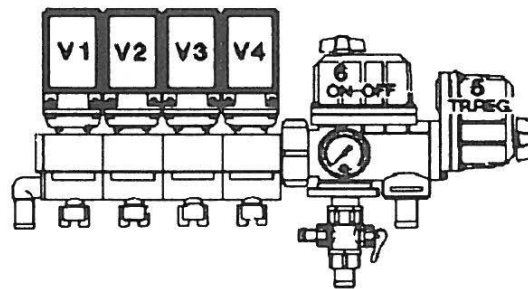

Fuse type T 500mA
 HARDI no. 261125

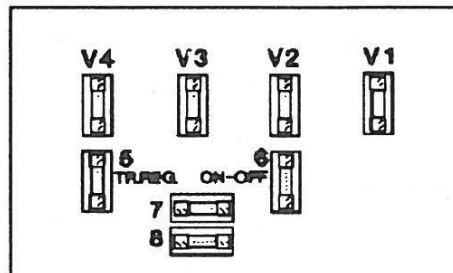

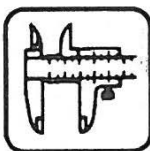

Technical specifications

Measure and weight

Tank size l	Wheel-size "	Spraying width m	Measure a x b x c cm	Weight kg
1500	36	12	460 x 246 x 275	1420
		15	460 x 246 x 330	1445
		16	460 x 246 x 340	1460
		18	460 x 246 x 340	1480
2400	44	12	510 x 246 x 280	1690
		15	510 x 246 x 340	1715
		16	510 x 246 x 350	1730
		18	510 x 246 x 350	1750
		20	510 x 250 x 360	1890
		21	510 x 250 x 370	2110
		24	585 x 250 x 390	2155
3500	48	20	680 x 250 x 400	2225
		20	570 x 250 x 340	1995
		21	570 x 250 x 350	2215
		24	585 x 250 x 370	2260
3500	32	28	680 x 250 x 400	2330
		20	570 x 250 x 335	2371
		21	570 x 250 x 345	2391
		24	585 x 250 x 370	2436

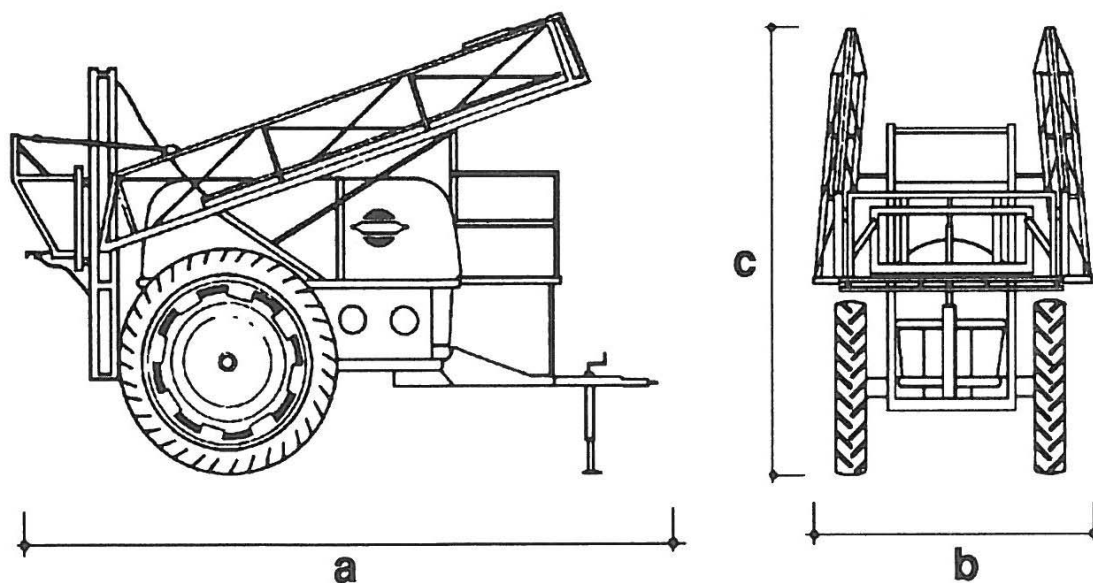

Power consumption and capacity



361/9.5	r/min									
	300		400		500		540		600	
bar	l/min	kW	l/min	kW	l/min	kW	l/min	kW	l/min	kW
0	95	0,92	127	1,33	158	1,56	171	1,69	189	1,85
5	92	1,49	123	1,93	151	2,38	165	2,63	183	2,98
10	91	2,22	120	2,89	148	3,69	163	4,02	180	4,74
15	89	3,03	119	3,92	148	4,90	160	5,40	177	6,15
Rotation per min.	r/min	Capacity				l/min	Suction height			0,0 m
Power consumption	kW	Max. pressure				15bar	Weight			54,0 kg

462/10.0	r/min									
	300		400		500		540		600	
bar	l/min	kW	l/min	kW	l/min	kW	l/min	kW	l/min	kW
0	134	0,94	180	1,23	223	1,56	242	1,69	265	1,91
5	130	1,71	173	2,36	213	2,97	231	3,21	254	3,69
10	127	2,69	169	3,69	209	4,82	226	5,37	248	6,00
15	125	3,71	166	5,03	205	6,28	221	6,87	243	7,66
Rotation per min.	r/min	Capacity				l/min	Suction height			0,0 m
Power consumption	kW	Max. pressure				15 bar	Weight			70,0 kg

Filters and nozzles

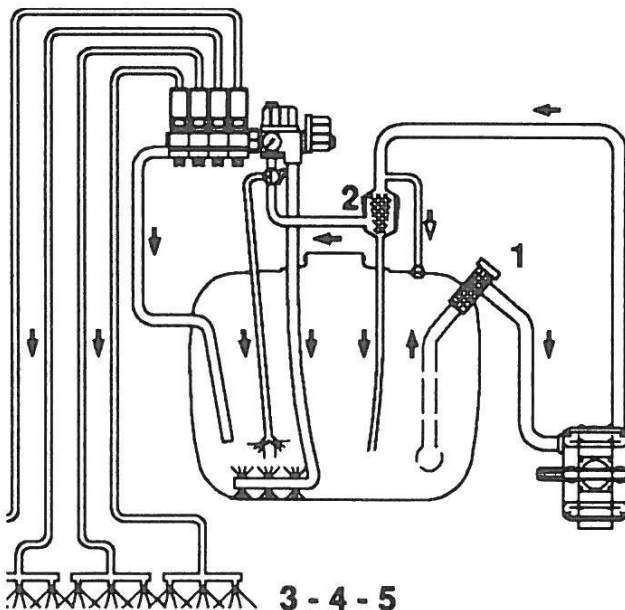

Pos.	Mesh/ colour	Description/ nozzle
1	30	Suction filter
2	80	Self-cleaning filter
3	50 blue	Nozzle 4110-14
4	50 blue	Nozzle 4110-16
5	50 blue	Nozzle 4110-20



Electric and hydraulic diagram Distribution box

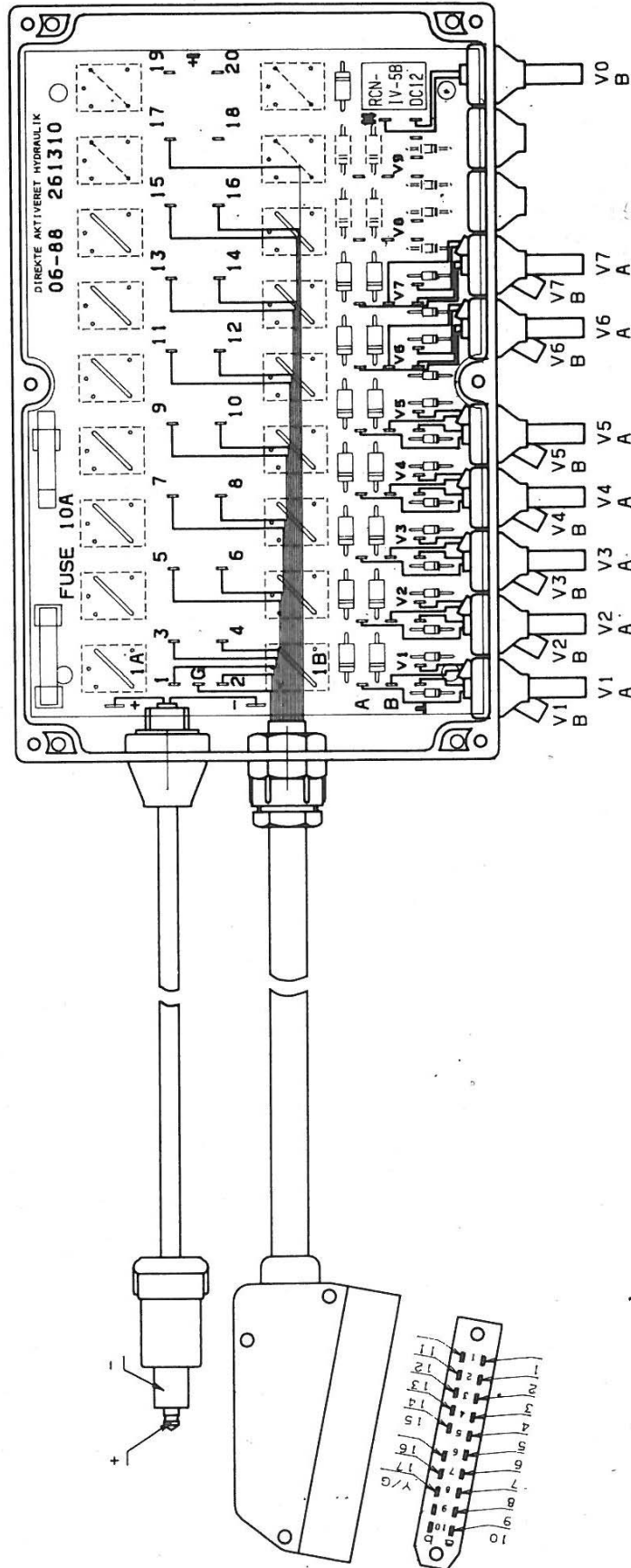

23-11-90 LZ/TZ

Hydraulic system

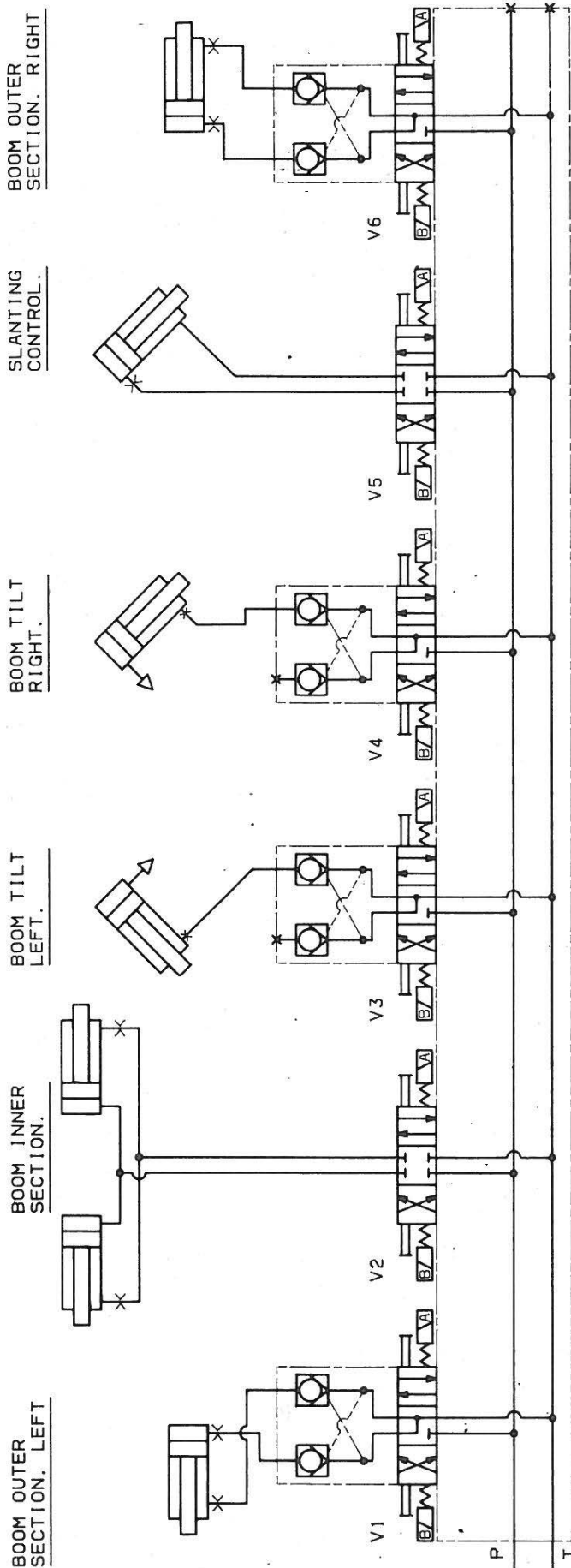

HYDRAULIC SPEC.:

MAX. INLET FLOW FROM TRAC.: $Q_s \leq 90$ L/MIN.
 INTERNAL PRESSURE RELIEF VALVE: 245 BAR.
 ORIFICE: (a) = $\emptyset 2,0$. (b) = $\emptyset 2,0$.
 (c) = $\emptyset 0,8$. (d) = $\emptyset 0,8$.

DIRECTIONAL VALVES:

V2, V5.: DG4V-3-2C-HMU G7 60 EU38 (LOW LEAKAGE VERSION)
 V1, V3, V4, V6, V7: DG4V-3-6C-HMU G7 60
 V0: DG4V-3-0B HMU G7 60 (REDUCED PIN), CHECK VALVES: DGMPC-3-ABK-BAK.
 VALVES ARE PRODUCED BY VICKERS, HAVANT.

23-11-90 LZ/TZ

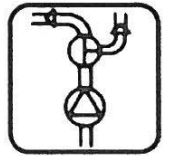



Boom raise/lower

BOOM
RAISE/LOWER.

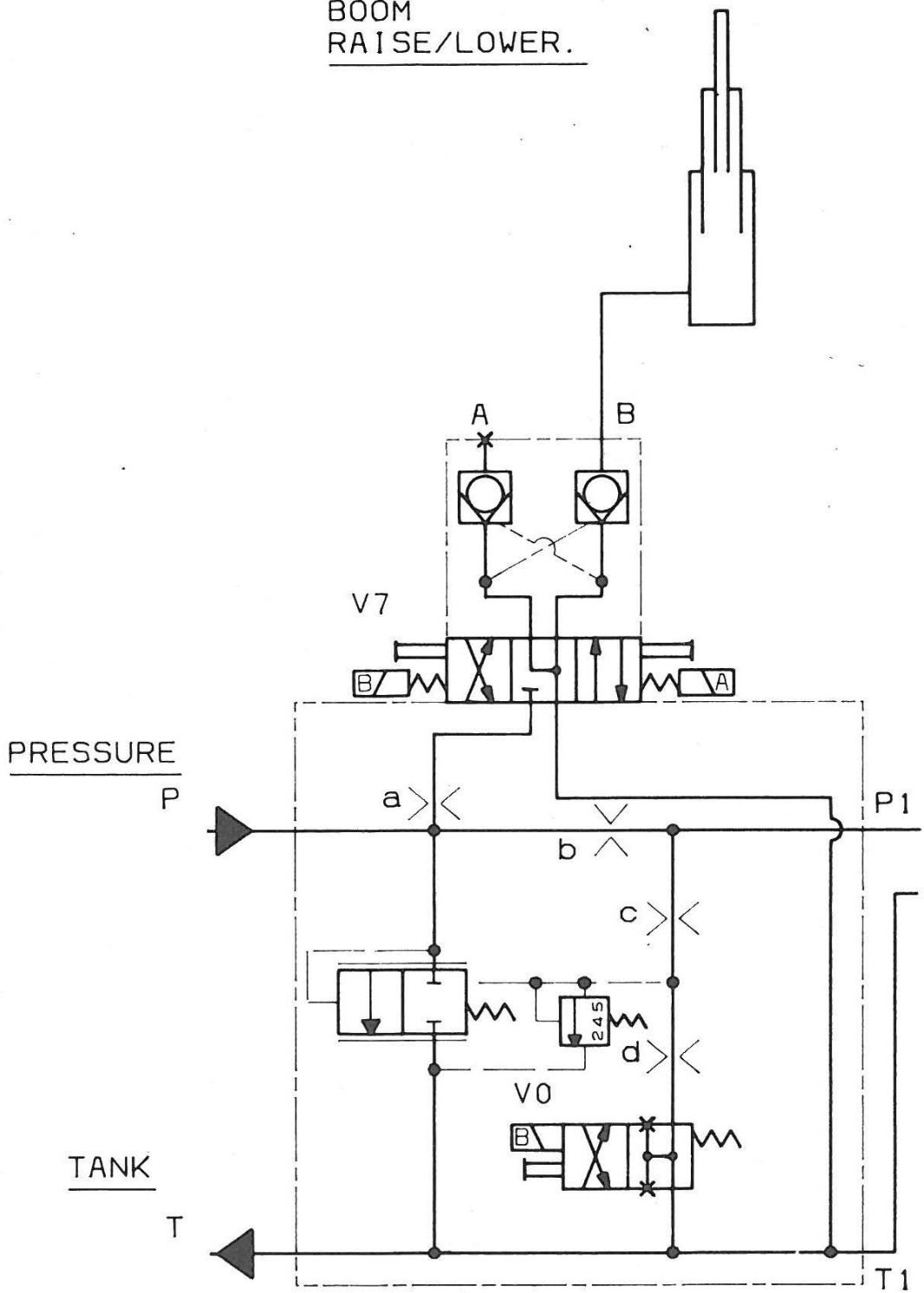

Before 1-8-92

23-11-90 LZ/TZ

Boom raise/lower

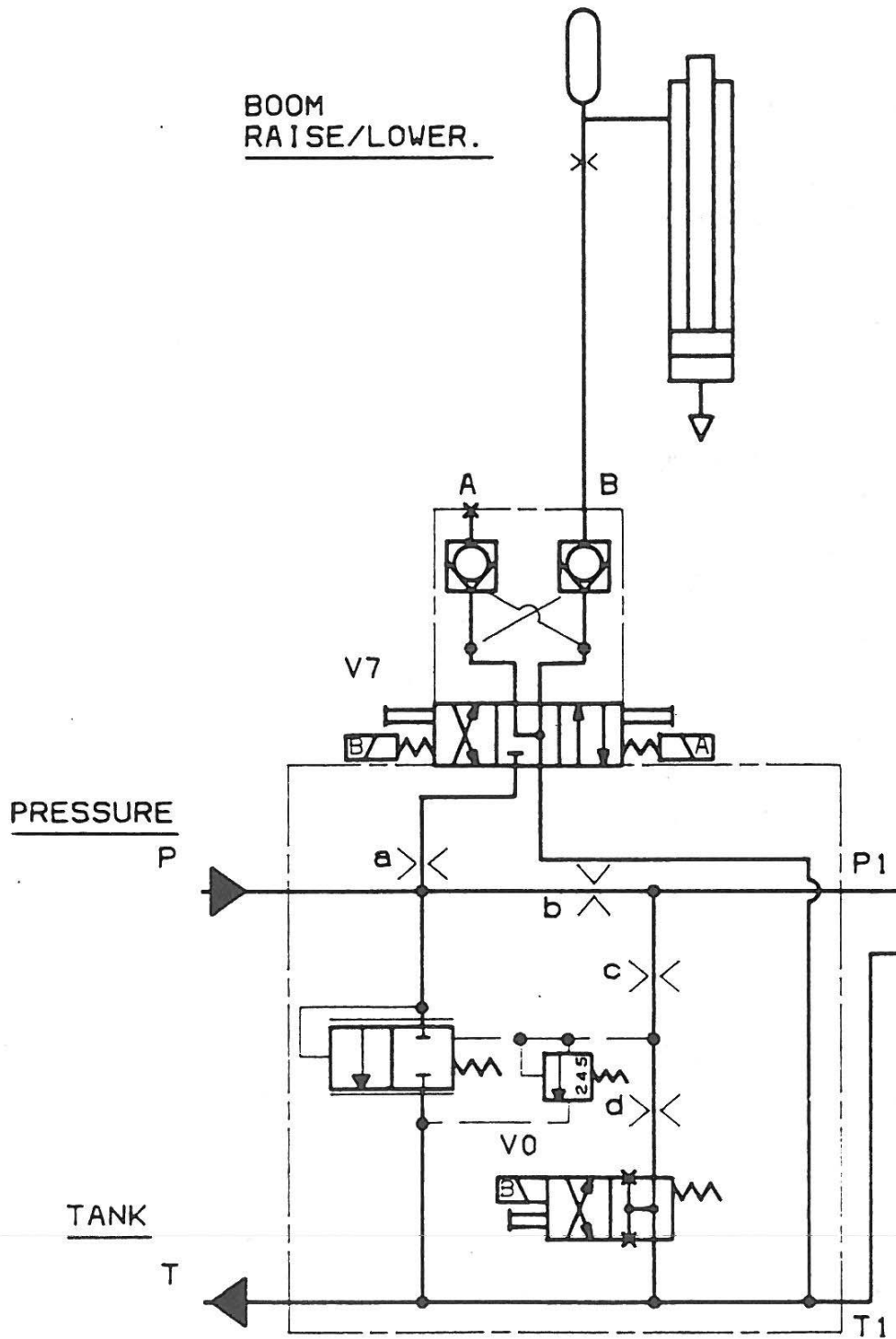
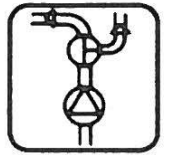

After 1-8-92

3-11-92

LZ/TZ



Pictorial symbols



Description

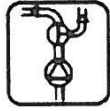

Function



Connection



Warning



Operating



Service/adjustment



Liquid flow



Pressure



Cleaning



Lubrication



Winter off-season storage

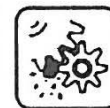

Operational problems



Technical specifications

Assembly

Preassembly information

The sprayer is supplied ex-works in shipping packages (SP). Number of SP's per sprayer varies depending on model.

As this covers all TZ models, please note the fittings covering exactly your model.

NOTE:

Removal of the plastic bag covering the tank is easiest done before assembly.

Some components are shipped within the tank. Check inside.

A crane or forklift will be needed to raise the gantry and boom from the shipping position.

Packaging Information

Materials used for packaging are environmentally compatible. They can be safely deposited or they can be burnt in an incinerator.

Recycling

Cardboard: Can recycle up to 99% and therefore should be put into the waste collection system.

Polystyrene foam: Can be recycled. Fluorocarbons (CFC) not used in foam production.

Polyethylene: Can be recycled.

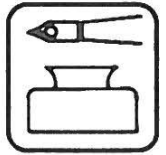

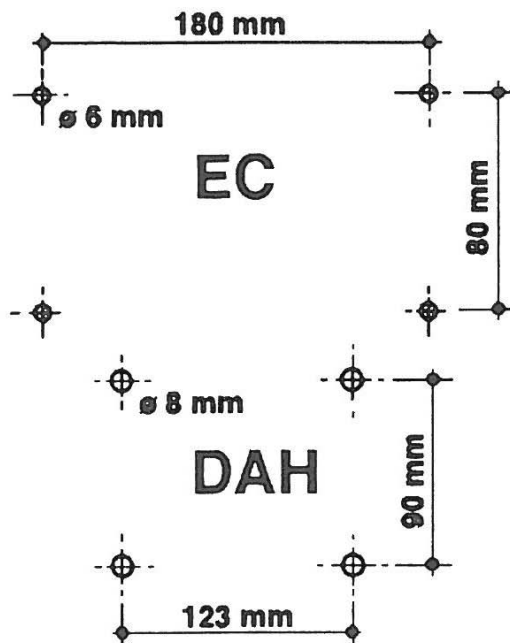
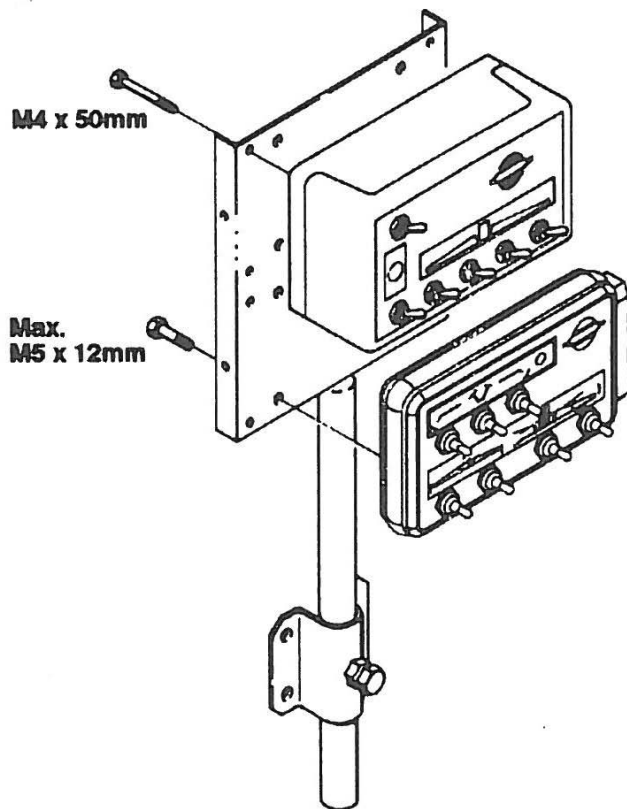

1. Mount the boxes on the holder delivered, or on a suitable bracket for the purpose.



WARNING! The screws for mounting the D.A.H. control box must not be too long (max. 12 mm) as they may cause a short circuit!

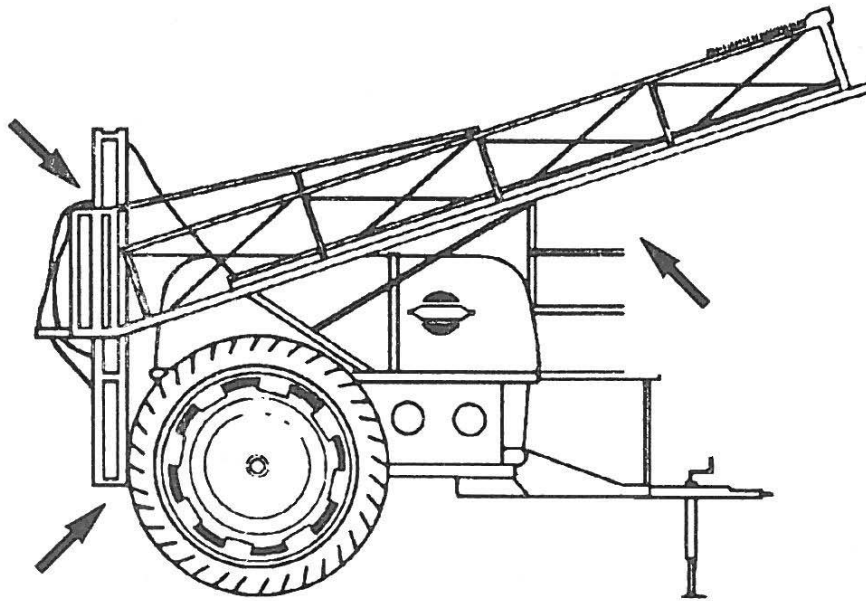

2. Gantry and boom need to be raised from the shipping position. A crane or forklift will be needed. The easiest method is to unfold the boom inner sections before removing nuts and bolts (→).



WARNING; Remember to secure the sprayer from over-balancing.

3. Another method is to first remove tilt ram pins **A** and then raise gantry. Then the left and right booms will have to be raised so the pins **A** can be reinserted. Be cautious of boom transport brackets when lifting the gantry.

4. Remove the black shipping transport brackets and mount the red brackets.

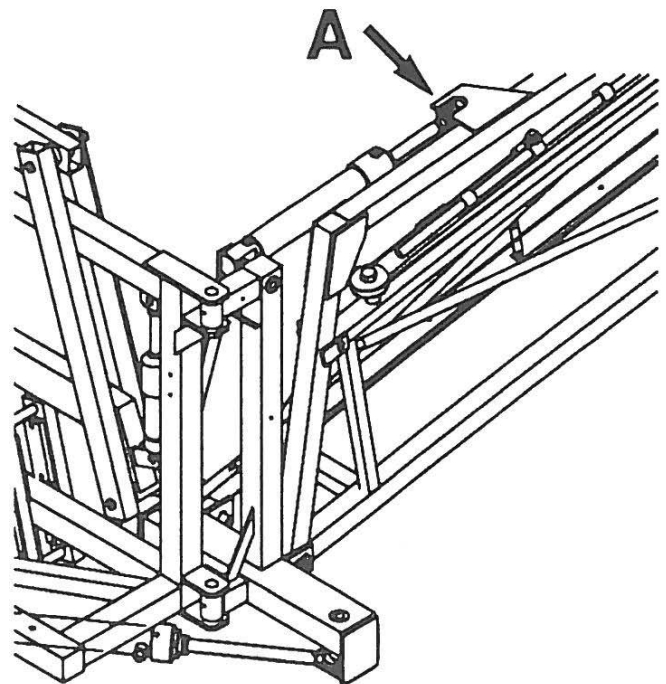

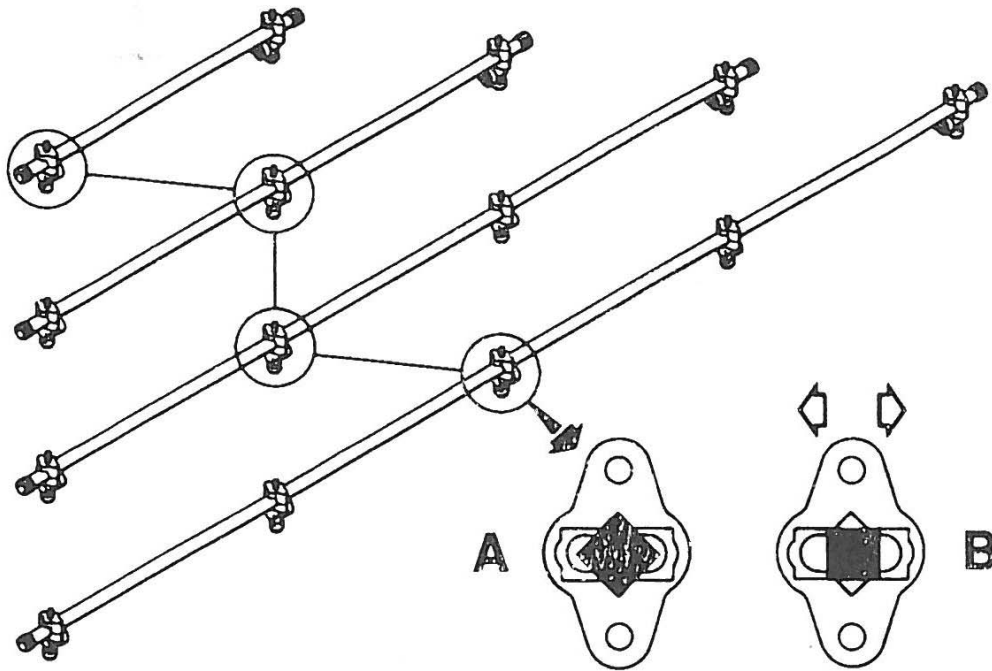

5. Nozzle tubes are supplied with one lock nozzle saddle per tube A. The rest can slide lengthwise B allowing for extension and contraction.

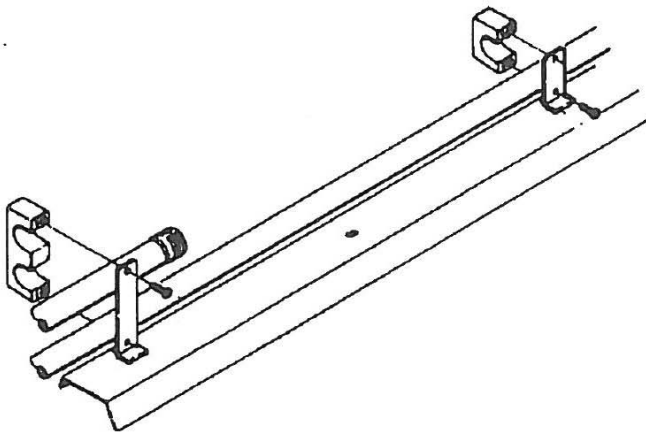

6. Tubes and hoses are connected.
Fit tubes using synthetic nut. Press down 1,
turn 2. Do not over-tighten.

Fit filter and COLOR TIPS.
REMEMBER: Lubricate O-rings before fitting.

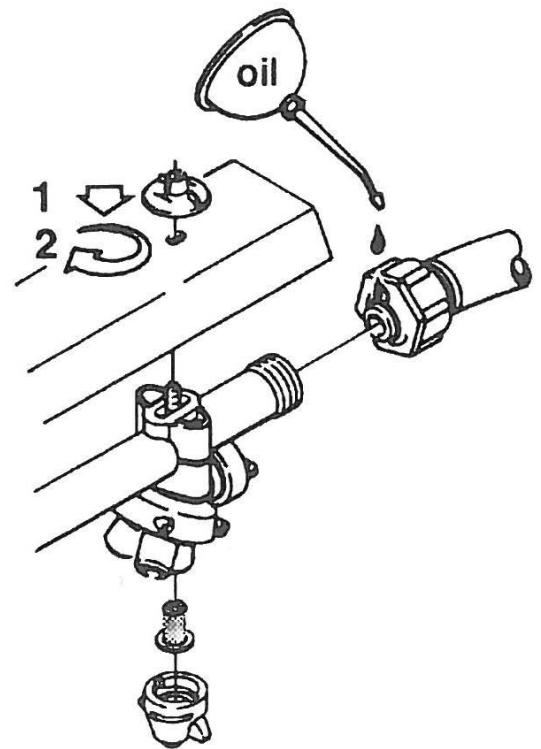

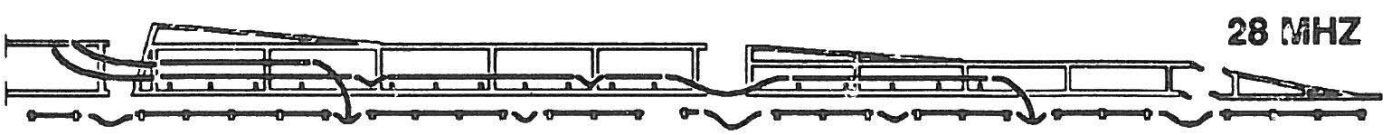
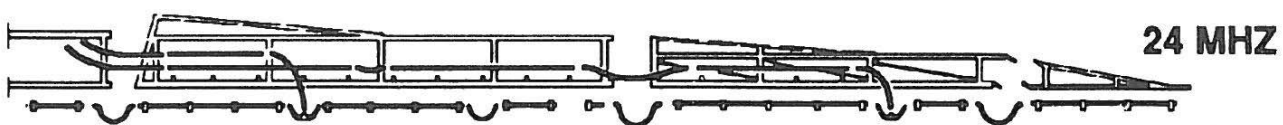
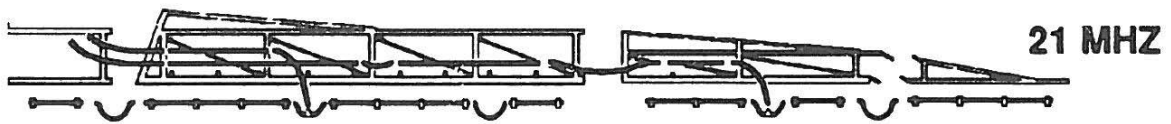
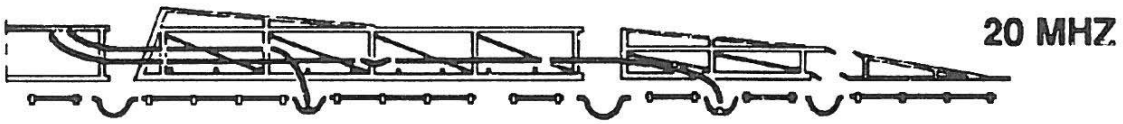
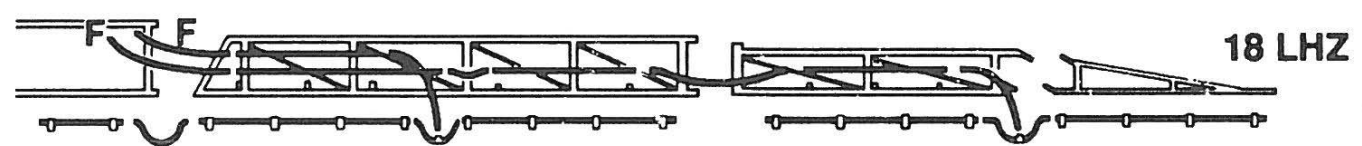
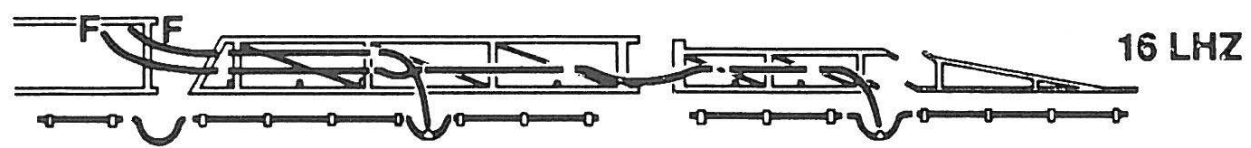
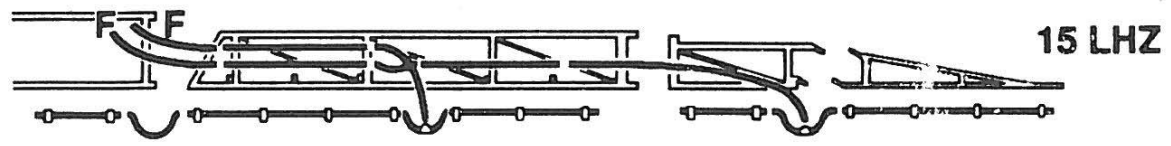
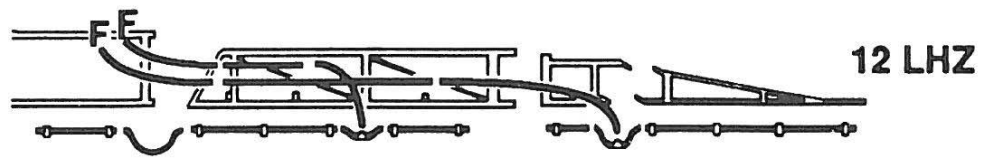

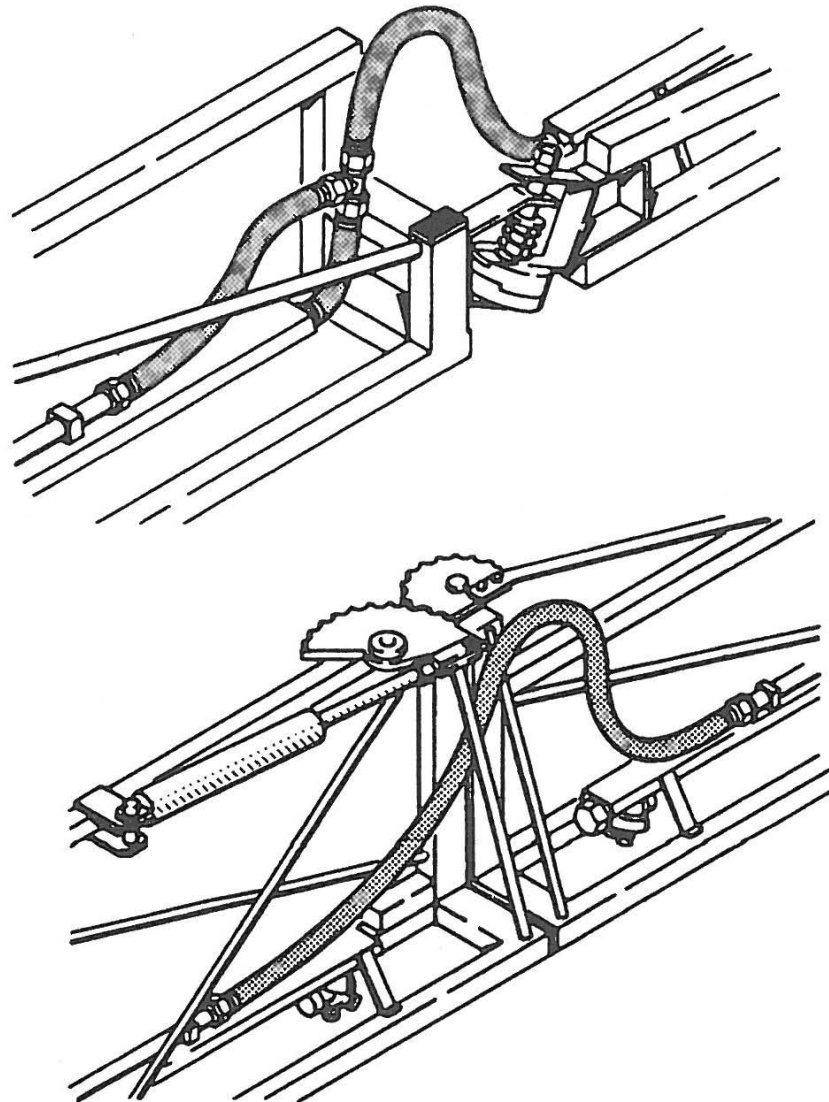

7. Secure feed and connecting hoses with plastic straps (approx. every 30 cm). Check that the hoses do not catch or pinch during folding and unfolding.

