

# HARDI® SPRAYERS

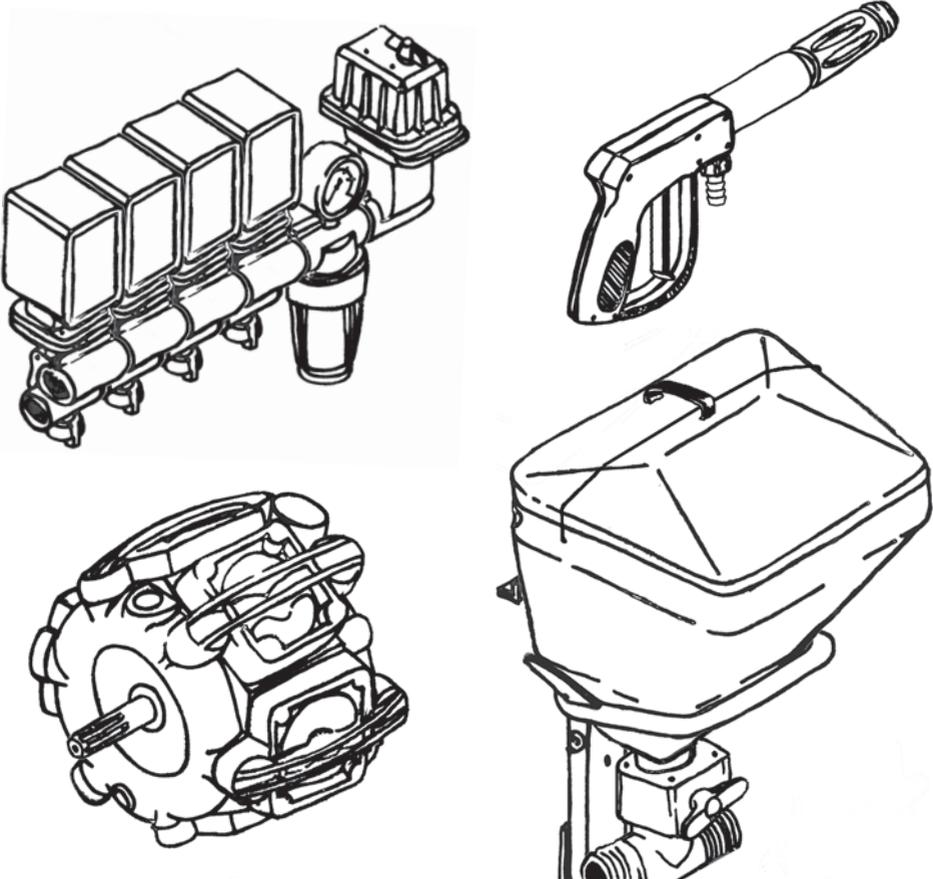

**N-SERIES 3-PT SPRAYER  
DIAPHRAGM  
Operator's Manual**

67303103 (01/20)

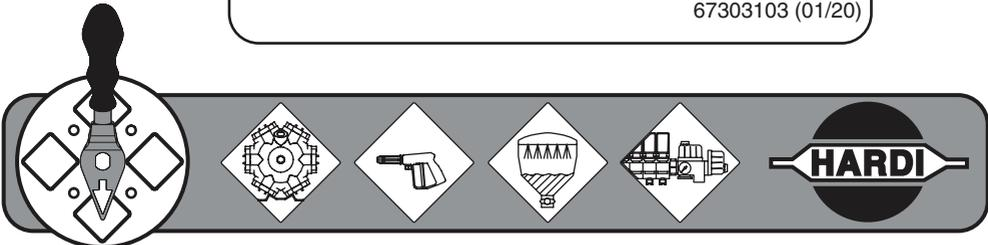





**N-SERIES 3-PT SPRAYER  
DIAPHRAGM  
Operator's Manual**

67303103 (01/20)

HARDI® reserves the right to make changes in design, material, or specification without notice thereof. HARDI® and other product names are registered trademarks of HARDI® Inc. in the U.S. and in other countries.



# TABLE OF CONTENTS

<b>1.0 INTRODUCTION</b> .....	<b>6</b>
<b>2.0 SAFETY INFORMATION</b> .....	<b>8</b>
2.1 Follow Safety Instructions .....	9
2.2 Operating the Sprayer Safely .....	9
2.3 Handling Chemical Products Safely .....	11
2.4 Local Poison Information Center .....	12
<b>3.0 HOOKING UP THE SPRAYER</b> .....	<b>13</b>
3.1 P.T.O. Shaft Operator Safety .....	14
3.2 Installation Of P.T.O. Shaft .....	14
3.3 Power Supply (electric controls only) .....	16
3.4 Control box (electric controls only) .....	17
<b>4.0 OPERATING INSTRUCTIONS</b> .....	<b>18</b>
4.1 Filling The Main Tank (all models) .....	18
4.2 Filling The Clean Water Tank (optional) .....	18
4.3 EC-3 Standard Plumbing Diagram .....	19
4.4 EC-3 Plumbing Diagram w/optional Rate Controller	20
4.5 Adjustment of the EC-3 Electric Controls .....	21
4.6 ET-3 Manual Control Plumbing Diagram .....	23
4.7 Adjustment of the ET-3 Manual Controls .....	24
4.8 ET-1 Manual Control Plumbing Diagram .....	26
4.9 Adjustment of the ET-1 Manual Controls .....	27
4.10 BK-3 Manual Control Plumbing Diagram .....	29
4.11 Adjustment of the BK-3 Manual Controls .....	30
4.12 Operation Of The Tank Drain Valve (all models) ...	33
4.13 Adjustment of Air Pressure in Pressure Damper (All models) .....	33
4.14 Unfolding/Folding Boom (All models with standard booms) .....	34
4.15 Boom Height Adjustment (All models with standard booms) .....	35



<b>5.0 NOZZLE SELECTION</b> . . . . .	<b>36</b>
5.1 Boom Nozzle Selection (All models with standard booms) . . . . .	36
5.2 Brass Boomless Nozzle (Pasture Sprayer only) . . .	39
5.3 Spraygun Nozzle Selection (All models) . . . . .	40
5.4 Calibration (All models with standard booms) . . . . .	41
5.5 Calibration (Pasture sprayer model only) . . . . .	45
<b>6.0 MAINTENANCE</b> . . . . .	<b>49</b>
6.1 Cleaning The Sprayer . . . . .	49
6.2 Filters . . . . .	51
6.3 Nozzles And Fittings . . . . .	52
6.4 Changing the Valves and Diaphragms (all pumps) .	53
6.5 Lubrication . . . . .	54
<b>7.0 OFF-SEASON STORAGE</b> . . . . .	<b>57</b>
7.1 Preparation after Off-Season Storage . . . . .	58
<b>8.0 ACCESSORIES</b> . . . . .	<b>59</b>
8.1 Clean Water Dispenser (optional) . . . . .	59
8.2 Spraygun And Hose wrap (optional) . . . . .	59
8.3 SprayMate II Rate Controller (optional) . . . . .	60
8.4 Large 4" Pressure Gauge (optional) . . . . .	60
8.5 Chemical Filler (optional) . . . . .	61
8.6 Chemical Filler Bag & Bottle Rinse Kit (optional) . .	61
8.7 SMV Sign Kit (optional) . . . . .	62
<b>9.0 TROUBLESHOOTING</b> . . . . .	<b>63</b>
9.1 General Spray Systems . . . . .	63
<b>10.0 TECHNICAL SPECIFICATIONS</b> . . . . .	<b>65</b>
10.1 Dimensions and weights . . . . .	65
10.2 Power consumption . . . . .	65
<b>11.0 WARRANTY POLICY AND CONDITIONS</b> . . . . .	<b>66</b>
<b>12.0 NOTES</b> . . . . .	<b>68</b>



Dear Owner,

Thank you for purchasing a HARDI® product and welcome to the ever-increasing family of HARDI® sprayer owners.

Our sprayers and accessories are rapidly becoming a familiar sight on North American farms. We believe that this results from growers becoming increasingly conscious of crop protection input costs and the vital need for cost effective spray application equipment.

Please take the time to thoroughly read the Operator's Manual before using your equipment. You will find many helpful hints as well as important safety and operation information.

Some of the features on your HARDI® sprayer were suggested by growers. There is no substitute for "on farm" experience and we invite your comments and suggestions. If any portion of this instruction book remains unclear after reading it, contact your HARDI® dealer or service personnel for further explanation before using the equipment.

**For Product, Service or Warranty Information:**

- Please contact your local HARDI® dealer.

**To contact HARDI® directly:**

- Please use the HARDI® Customer Service number: 1-866-770-7063  
- Or send your email to [CUSTSERV@hardi-us.com](mailto:CUSTSERV@hardi-us.com)

**Visit us online at: [www.hardi-us.com](http://www.hardi-us.com)**

**HARDI® NORTH AMERICA INC.**

1500 West 76th St.  
Davenport, Iowa 52806  
Phone: (563) 386-1730  
Fax: (563) 386-1280



*Fig. 1*

*N155 GALLON 3-PT WITH 26' SB BOOM*



*Fig. 2*

*N105 GALLON 3-PT PASTURE SPRAYER MODEL*



## 1.0 INTRODUCTION

We congratulate you for choosing a HARDI® plant protection product. The reliability and efficiency of this product depends on your care. The first step is to carefully read and pay attention to this operator's manual. It contains essential information for the efficient use and long life of this quality product.

As this instruction book covers all N-series models, please pay attention to the sections dealing with your specific model.

This manual covers the HARDI® N-series 3-PT sprayers, available in 105, 155 or 210 gallon (400 L, 600 L or 800 L) capacities. They are equipped with a HARDI® 603, 1203 or 1303 diaphragm pump (540 RPM P.T.O. drive), 3-PT frame and tank with electrical (EC) or manual (ET or BK) controls. Available standard booms include:

N105: 14' HD, 20' SB, 26' SB

N155: 14' HD, 20' SB, 26' SB, 33' SB, 40' SB

N210: 14' HD, 20' SB, 26' SB, 33' SB, 40' SB

Other boom options include: No boom (spray gun only) or pasture sprayer nozzles (50-52' spray width).

The heart of your sprayer is the diaphragm pump. The design is simple, resulting in low maintenance requirements and guaranteed pump life. The bearings and crankshaft are grease lubricated and are therefore protected from spray solution if any diaphragm fails in service. A drain hole is located in the base of the crank case to facilitate the draining of any foreign matter. The pump is self-priming and can be run dry without damage.

The EC-3 electric control unit consists of: Electrically operated master on/off valve, electrically operated boom distribution valves, manual pressure adjustment valve, 2-1/2" pressure gauge, and adjustable pressure agitation.

The ET-1/ET-3 manual control unit consists of: Manual pressure adjustment valve, boom distribution valves, 2-1/2" pressure gauge, and adjustable pressure agitation.

**Note:** ET-1 control is used on pasture sprayer model



The BK-3 manual control unit consists of: On/off function, distribution valves with pressure equalization, manual pressure adjustment valve, pressure filter with 2-1/2" pressure gauge and HARDI-MATIC. The HARDI-MATIC is a mechanical rate controller that ensures a constant volume of spray solution per acre at varying speeds in the same gear.

The tanks, made of impact proof and chemical resistant polyethylene, have a purposeful design with rounded contours and a large deep sump to allow for efficient cleaning and draining. The tanks are equipped with a top suction filter for easy service and a top operated tank drain.

All standard booms (20', 26', 33' or 40' SB) feature ISO flat fan nozzles with 20" spacing.

The pasture sprayer model includes a height adjustable nozzle bracket bolted to the rear of the 3-PT frame for mounting a brass boomless nozzle. The brass nozzle provides a maximum spray width of 52' (16m) under optimal spraying conditions.

Available options include:

Spray Mate II Rate Controller (requires electric EC control)

Remote control cable (for manual BK control only)

In-Line filter (with 50 mesh filter)

4 gallon (15 L) clean water dispenser

Chemical filler with optional bag & bottle rinse

4" pressure gauge

Hose wrap with 25' of 3/8" hose and a model 60L HARDI® spray gun

Hose reel with 150' of 1/2" hose and a model 60L HARDI® spray gun\*

Hydraulic boom vertical fold (SB boom only)

SMV Sign kit

\* Not available on N210 with boom





## 2.0 SAFETY INFORMATION

### WARNING



**ALWAYS READ OPERATOR'S MANUAL BEFORE  
USING EQUIPMENT**

**DO NOT REMOVE ANY SAFETY DEVICES OR  
SHIELDS. NEVER SERVICE, CLEAN OR REPAIR A  
MACHINE WHILE IT IS OPERATING**

### WARNING



**ALWAYS WATCH FOR THIS SYMBOL TO POINT OUT  
IMPORTANT SAFETY PRECAUTIONS**

**IT MEANS ATTENTION! BECOME ALERT!  
YOUR SAFETY IS INVOLVED!**



## RECOGNIZE SAFETY INFORMATION

**This is the Safety-alert symbol. When you see this symbol on your machine or in this manual, be alert to the potential for personal injury. Follow recommended precautions and safe operating practices.**



### 2.1 Follow Safety Instructions

- Carefully read all the safety messages in this manual and the safety labels fitted to the machine. Keep safety labels in good condition. Replace missing or damaged safety labels. Be sure that new equipment components include any current safety labels. Replacement safety labels are available from your authorized HARDI® dealer.
- Learn how to operate the sprayer and how to use the controls properly. Do not let anyone operate the machine without proper instructions.
- Keep your sprayer in proper working condition. Unauthorized modifications or use may impair the function and/or safety and affect the machine's life.
- If you do not understand any part of this manual and need assistance, please contact your authorized HARDI® dealer.

### 2.2 Operating The Sprayer Safely

1. Read the complete manual carefully and become familiar with the operation of the equipment before initial operation in each spraying season. Failure to do so may result in possible over or under-application of spray solution which may drastically affect crop production and lead to personal injury.
2. Before starting the engine on the tractor unit, be sure all operating controls are in the off or neutral position (including spray controls) and disengage the tractor power train.
3. Operate spray functions only when seated in the operator's seat.
4. One of the most frequent causes of personal injury or death results from persons falling off or being run over. Do not permit others to ride on or in. Only one person, the operator, should be on the machine when in operation.



5. Before leaving the tractor seat, stop the engine, put all controls in neutral, and put the transmission control lever in the park position or neutral with the brakes locked. Read the tractor operations manual for added safety precautions.
6. P.T.O. driven equipment can cause serious injury. Before working on or near the P.T.O. shaft, servicing or cleaning the equipment, put P.T.O. lever in the DISENGAGE position and stop the engine.
7. Keep hands, feet & clothing away from moving parts.
8. Wear relatively tight and belted clothing to prevent from being caught on some part of the machine.
9. Slow down when turning.
10. Always keep children away from your sprayer and/or tractor unit.
11. Slow moving tractors and spray equipment can create a hazard when on public roads. Avoid personal injury or death resulting from any accidents by using flashing lights. Local regulations may require installation of flashing warning lights.
12. Understand service procedures before undertaking any maintenance. Never lubricate, service, or adjust the machine while it's moving. Securely support any components before working on them.
13. Keep all parts in good condition and properly installed. Fix damaged parts immediately. Replace worn or broken parts. Remove excessive buildup of grease, oil or debris.

## 2.3 Handling Chemical Products Safely

1. Direct exposure to hazardous chemicals can cause serious injury. These chemicals can include lubricants, coolants, paints, adhesives and agricultural chemicals. Material Safety Data Sheets (M.S.D.S.) are available for all hazardous chemicals which inform the user of specific details including, physical and health hazards, safety procedures, and emergency response techniques.
2. Protective clothing such as rubber gloves, goggles, coveralls and respirator must be worn while handling chemicals. All protective clothing should be kept in excellent condition and cleaned regularly or discarded.
3. If chemicals come in contact with any exposed skin areas, wash immediately with clean water and detergent. Never place nozzle tips or any other components that have been exposed to chemicals to lips to blow out obstructions. Use a soft brush to clean spray nozzles.
4. Dedicate an area to fill, flush, calibrate and decontaminate sprayer where chemicals will not drift or run off to contaminate people, animals, vegetation, water supply, etc. Locate this area where there is no chance of children coming in contact with this residue.
5. Decontaminate equipment used in mixing, transferring and applying chemicals after use. Follow the instructions on the chemical label for the correct procedure required. Wash spray residue from outside of the sprayer to prevent corrosion.
6. Extreme care should be taken in measuring spray products. Powders should be used in suitable sized packages or weighed accurately. Liquids should be poured into a suitable graduated container. Keep chemical containers low when pouring. Wear a filtered respirator and let the wind blow away from you to avoid dust and/or splashes contacting the skin or hair.
7. Store chemicals in a separate, plainly marked locked building. Keep the chemical in its original container with the label intact.
8. Dispose all empty containers after rinsing in accordance with local regulations & by-laws. Dispose of all unused chemicals and left over fertilizer in an approved manner
9. Keep a first aid kit and fire extinguisher available at all times when handling chemicals.





## 2.4 Local Poison Information Center

If you live anywhere in the United States, the following toll free number will connect you to your Local Poison Information Center.

**PHONE NO. 1 - 8 0 0 - 2 2 2 - 1 2 2 2**

If you live outside the United States, find the number for the poison control center in your phone book and write it in the space below:

**PHONE NO.** \_\_\_\_\_ - \_\_\_\_\_ - \_\_\_\_\_

Keep a list, in the space provided below, of all the chemicals that you have in use.

1. \_\_\_\_\_
2. \_\_\_\_\_
3. \_\_\_\_\_
4. \_\_\_\_\_
5. \_\_\_\_\_
6. \_\_\_\_\_
7. \_\_\_\_\_
8. \_\_\_\_\_
9. \_\_\_\_\_
10. \_\_\_\_\_

## 3.0 HOOKING UP THE SPRAYER

**WARNING: MAKE SURE THAT YOUR TRACTOR HAS SUFFICIENT HORSEPOWER, BRAKING ABILITY AND CARRYING CAPACITY TO SAFELY CONTROL THE TRACTOR WITH THE SPRAYER MOUNTED.**

Check your tractor operator's manual for 3 point lifting capacity (See section 10.1 for approximate weight of your N-series model sprayer and section 10.2 for minimum tractor power requirements).

1. Attach lower lift arms.
2. Attach P.T.O. shaft (See sections 3.1 and 3.2).
3. Attach top link.

**IMPORTANT: *Make absolutely sure that the correct 3 point hitch pins are used and that they are securely installed.***

4. Raise sprayer from ground and adjust 3 point linkage so that tank is level in the raised position (ensure that the sprayer tank is level from side to side as well as front to back).
5. Also follow these general recommendations:
  - Increase tire pressure if necessary (refer to tractor operator's manual) to compensate for the added weight.
  - Make sure that no parts of the sprayer come into contact with the tractor.
  - Be careful when filling the sprayer for the first time.
  - Travel at slower speeds when driving with a full tank.

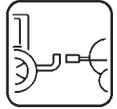



### 3.1 P.T.O. Shaft Operator Safety

**WARNING:** ALWAYS STOP ENGINE BEFORE ATTACHING THE TRANSMISSION SHAFT TO TRACTOR P.T.O. - MOST TRACTOR P.T.O. SHAFTS CAN BE ROTATED BY HAND TO FACILITATE SPLINE ALIGNMENT, WHEN ENGINE IS STOPPED.



When attaching the shaft, make sure that the snap lock is FULLY ENGAGED - push and pull shaft until it locks.



**WARNING:** ROTATING TRANSMISSION SHAFTS WITHOUT PROTECTION GUARDS ARE FATAL.

Always keep protection guards and chains intact and make sure that it covers all rotating parts, including CV-joints at each end of the shaft. Do not use without protection guard.

Do not touch or stand on the transmission shaft when it is rotating - safety distance: min 5' (1.5 meters).

Prevent protection guards from rotating by attaching the chains, allowing sufficient slack for turns.

Make sure that protection guards around tractor P.T.O. and implement shaft are intact. Check every 40 hours.

Always **STOP ENGINE** and remove the ignition key before carrying out maintenance or repairs to the transmission shaft or implement.

### 3.2 Installation Of P.T.O. Shaft

**WARNING:** THE P.T.O. SHAFT ANGLE WILL CHANGE WHEN RAISING AND LOWERING THE 3 POINT LINKAGE. TO PREVENT EXCESSIVE LOADING AND BINDING ON THE P.T.O. SHAFT, IT MAY BE ADVISABLE TO LEAVE THE P.T.O. SHAFT DISCONNECTED UNTIL THIS OPERATION IS COMPLETED. THEN P.T.O. SHAFT ADJUSTMENTS CAN BE MADE.



Initial installation of the shaft is done as follows:

1. Attach sprayer to tractor and set sprayer in the position with **shortest** distance between the tractor and sprayer pump P.T.O. shafts.
2. Stop engine and remove ignition key.



### 3.2 Installation Of P.T.O. Shaft (continued)

3. If P.T.O. shaft must be shortened, pull the shaft apart. Fit the two shaft parts at tractor and sprayer pump and measure how much it is necessary to shorten the shaft. Mark the protection guards.

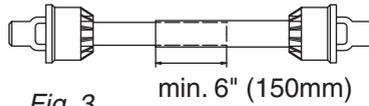
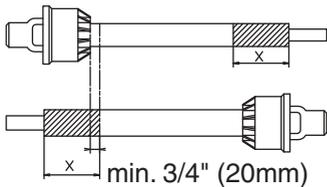

Fig. 3

**Note:** The shaft must always have a minimum overlap of 6" (150 mm) (Fig. 3).

4. Shorten the two parts equally. Use a saw, and file the profiles afterwards to remove burrs (Fig. 4).

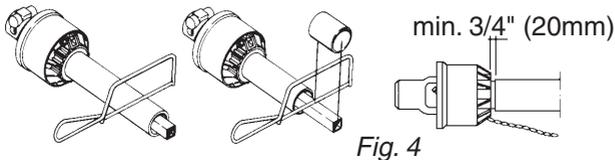

Fig. 4

5. Grease the profiles, and reassemble the male and female parts.  
6. Fit the shaft to tractor and sprayer pump.

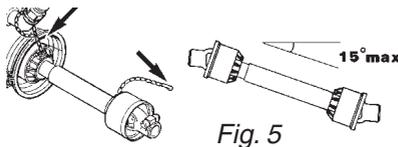

Fig. 5

**Note:** Female part towards tractor. Fit the chains to prevent the protection guards from rotating with the shaft.

7. To ensure long life of the P.T.O. shaft, try to avoid working angles greater than 15° (Fig. 5).





### 3.3 Power Supply (electric controls only)

A 12 Volt DC power supply is required to operate the electrical boom distribution valve solenoids (Fig. 6). Connect the power supply wiring harness as follows:

Red wire to positive (+) and Black wire to negative (-).



**IMPORTANT:** *Do not connect to the starter motor or generator/alternator. Warranty is void if this is done.*

The power supply wiring harness is equipped with a 7.5 Amp inline fuse to protect the control box.

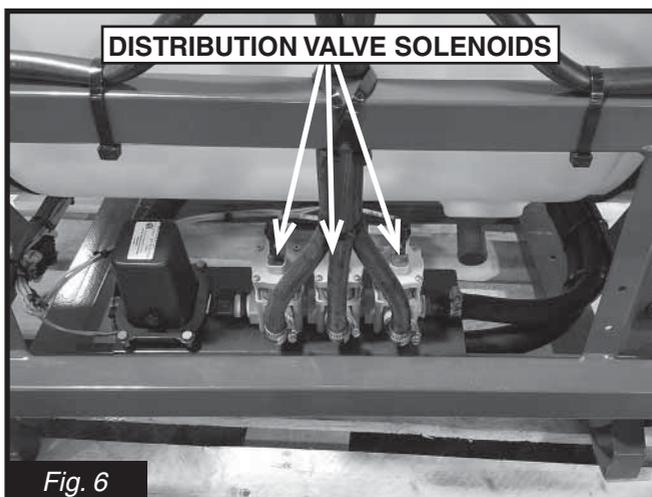

Fig. 6

### 3.4 Control box (electric controls only)

The HARDI® N-series 3-PT sprayer equipped with electric controls uses an electrical control box for master on/off control and individual boom section on/off control. An optional rate controller box is also available.

1. Mount the control box in a convenient location near the operator.
2. Route the power supply (installed in section 3.3) to the small plug on the control box.
3. Route the main wiring harness from the sprayer to the large plug on the control box.

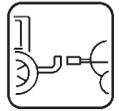

Fig. 7



## 4.0 OPERATING INSTRUCTIONS

### 4.1 Filling The Main Tank (all models)

Water is filled into the tank by removing the tank lid located at the center of sprayer tank. It is recommended to use water as clean as possible for spraying purposes. Fill water through the strainer basket (optional) to prevent foreign particles from entering the tank.



**WARNING: DO NOT LET THE FILLING HOSE ENTER THE TANK. KEEP IT OUTSIDE THE TANK, POINTING TOWARDS THE FILLING HOLE (FIG. 8). IF THE END OF THE HOSE IS BENEATH THE SURFACE OF THE TANK CONTENTS AND THE WATER SUPPLY STOPS, CHEMICALS MAY BE SIPHONED BACK AND CONTAMINATE THE WATER SUPPLY SOURCE AND LINES.**

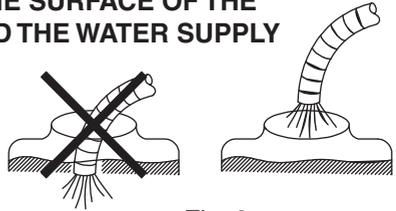

Fig. 8

### 4.2 Filling The Clean Water Tank (optional)

Unscrew the clean water tank lid and fill with clean water only.



**IMPORTANT: *The water from this tank is only for hand washing, cleaning blocked nozzles, etc.***

**WARNING: ALTHOUGH THE HANDWASH TANK IS ONLY FILLED WITH CLEAN WATER, THE WATER MUST NEVER BE USED FOR DRINKING, DUE TO THE SMALL RISK OF CONTAMINATION WHILE FILLING, ETC.**

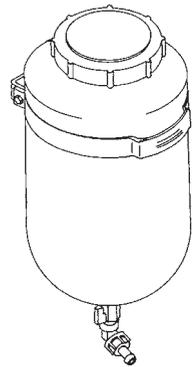

Fig. 9

### 4.3 EC-3 Standard Plumbing Diagram

Review and study the following diagram. By following the flow through the diagram, you will better understand the various functions of your sprayer system.

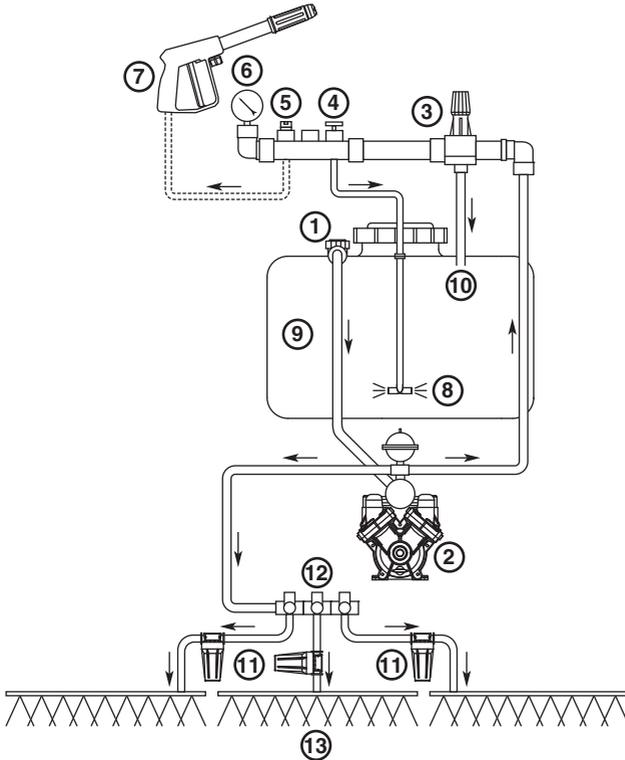

Fig. 10

- |                              |                                |
|------------------------------|--------------------------------|
| 1. Top Suction               | 8. Agitation                   |
| 2. Diaphragm Pump            | 9. Tank                        |
| 3. Pressure Control Valve    | 10. Bypass Return              |
| 4. Agitation Valve           | 11. In-Line Filters (optional) |
| 5. Spraygun Valve (optional) | 12. Boom Distribution Valves   |
| 6. System Pressure Gauge     | 13. Boom                       |
| 7. Spraygun (optional)       |                                |



## 4.4 EC-3 Plumbing Diagram w/optional Rate Controller

Review and study the following diagram. By following the flow through the diagram, you will better understand the various functions of your sprayer system.

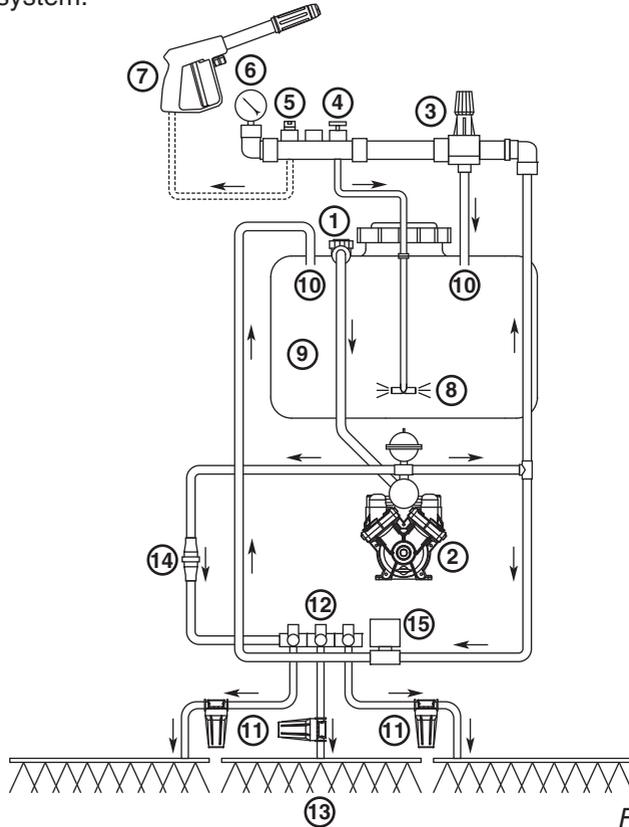

Fig. 11

- |                              |                                |
|------------------------------|--------------------------------|
| 1. Top Suction               | 9. Tank                        |
| 2. Diaphragm Pump            | 10. Bypass Returns             |
| 3. Pressure Relief Valve*    | 11. In-Line Filters (optional) |
| 4. Agitation Valve           | 12. Boom Distribution Valves   |
| 5. Spraygun Valve (optional) | 13. Boom                       |
| 6. System Pressure Gauge     | 14. Flowmeter                  |
| 7. Spraygun (optional)       | 15. Pressure Regulator         |
| 8. Agitation                 |                                |

\*Turn Pressure Relief Valve clockwise all the way in when used with the optional Rate Controller. Refer to SprayMate Operator's manual for adjustment of the controls.

## 4.5 Adjustment of the EC-3 Electric Controls

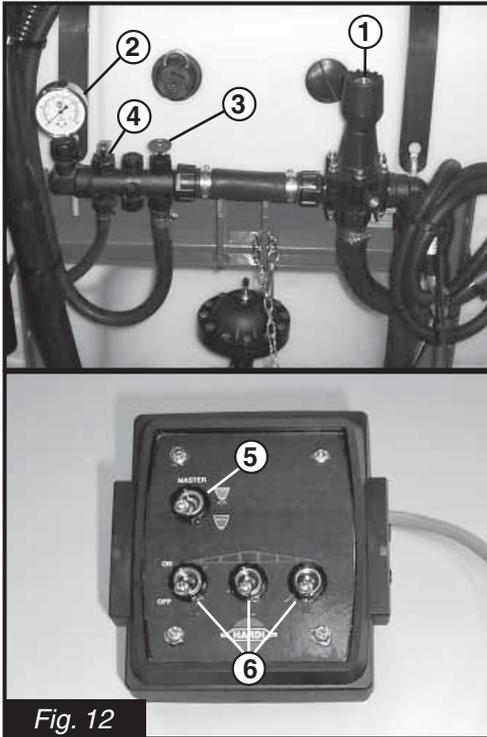

Fig. 12

### SPRAYER CONTROLS:

1. Pressure control valve
2. System Pressure gauge
3. Agitation valve
4. Spraygun valve (optional)

### CONTROL BOX:

5. Master On/Off Switch
6. Distribution Switches

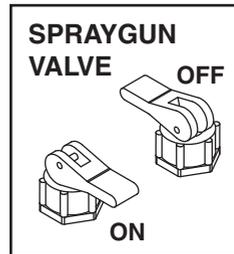

### Boom Operation

1. Choose the correct nozzle. Make sure that all nozzles are the same type and capacity. Refer to section 5.0 for nozzle selection and calibration.
2. Locate your sprayer in a suitable location to spray water from the boom. Fill the tank with clean water (see section 4.1).
3. Turn the Pressure Control Valve **1** (Fig. 12) counter clockwise all the way out.
4. Set Master On/Off boom switch **5** and individual boom switches **6** (Fig. 12) "ON". Set spraygun valve **4** (Fig. 12) "OFF".
5. With the tractor in neutral, engage the P.T.O. to start the pump. Adjust the R.P.M.'s to normal operating speed.
6. Increase pressure by turning Pressure Control Valve **1** (Fig. 12) clockwise. Adjust until the pressure gauge **2** (Fig. 12) reaches the desired pressure (turn Pressure Control Valve counter clockwise to decrease pressure).



### Operating the Spraygun (optional)

7. Set spraygun valve **4** (Fig. 12) "ON" and set Master On/Off boom switch **5** (Fig. 12) "OFF".
8. Then depress the red handle **A** (Fig. 13) to spray fluid from the spraygun. Check the pressure on the system pressure gauge **2** (Fig. 12) and follow step **6** to adjust.
9. To adjust the spray pattern, turn the black handle **B** (Fig. 13) OUT for a narrow spray pattern for long distances and IN for a wide pattern for more coverage at close distances.

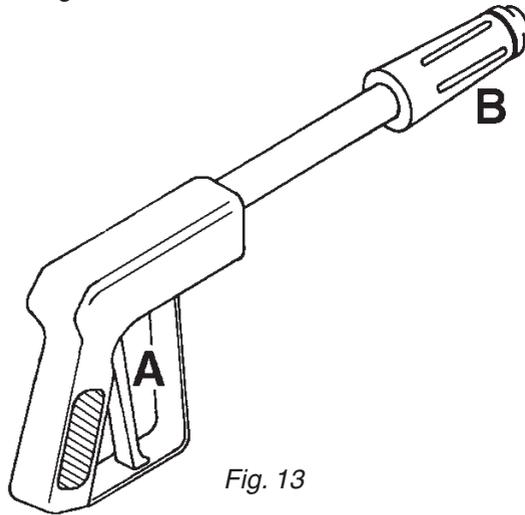

Fig. 13

### Agitation Adjustment

Agitation is necessary to keep the solution in your tank properly mixed. Consult your chemical supplier for the recommended amount of agitation.

In general, maximum agitation is required but some products tend to foam easily. To reduce foaming in some instances anti-foaming agents may be added to the tank (Refer to chemical label). When running low liquid levels in the tank, agitation may be reduced to facilitate pump priming and avoid pressure fluctuations. Make sure that you have adjusted the agitation properly before sprayer calibration.

Turn the agitation valve **3** (Fig. 12) clockwise to reduce the agitation flow. Turn the valve counter-clockwise to increase the agitation flow.



## 4.6 ET-3 Manual Control Plumbing Diagram

Review and study the following diagram. By following the flow through the diagram, you will better understand the various functions of your sprayer system.

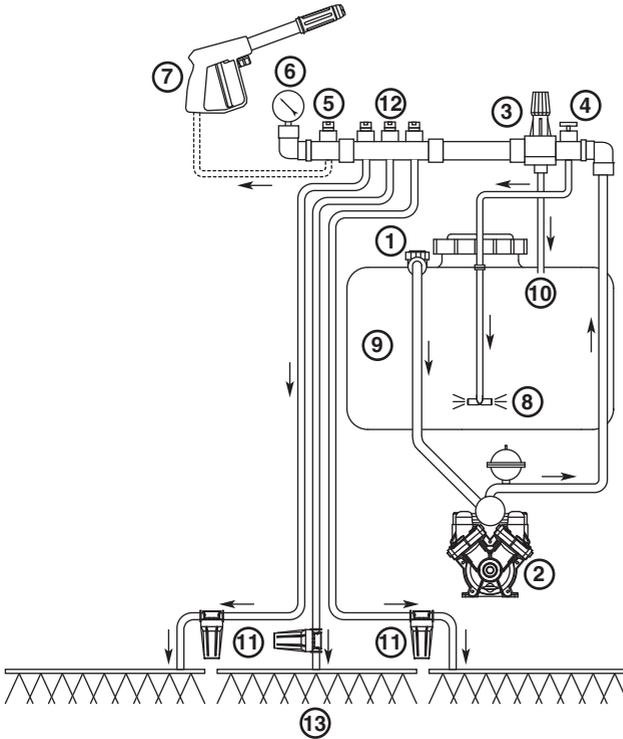

Fig. 14

- |                              |                                |
|------------------------------|--------------------------------|
| 1. Top Suction               | 8. Agitation                   |
| 2. Diaphragm Pump            | 9. Tank                        |
| 3. Pressure Control Valve    | 10. Bypass Return              |
| 4. Agitation Valve           | 11. In-Line Filters (optional) |
| 5. Spraygun Valve (optional) | 12. Boom Distribution Valves   |
| 6. System Pressure Gauge     | 13. Boom                       |
| 7. Spraygun (optional)       |                                |



## 4.7 Adjustment of the ET-3 Manual Controls

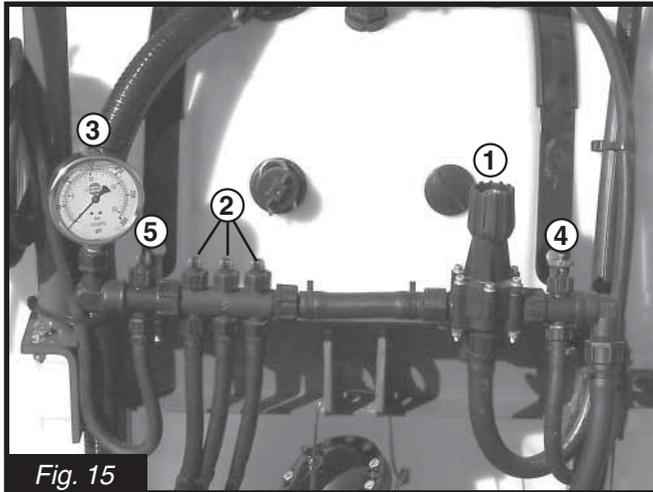
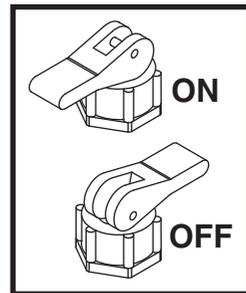

Fig. 15

1. Pressure control valve
2. Distribution valves
3. System pressure gauge
4. Agitation valve
5. Spraygun valve (optional)



### Boom Operation

1. Choose the correct nozzle. Make sure that all nozzles are the same type and capacity. Refer to section 5.0 for nozzle selection and calibration.
2. Locate your sprayer in a suitable location to spray water from the boom. Fill the tank with clean water (see section 4.1).
3. Turn the Pressure Control Valve **1** (Fig. 15) counter clockwise all the way out.
4. Set the three distribution valves **2** (Fig. 15) to the ON position. Set spraygun valve **5** (Fig. 15) to the OFF position.
5. With the tractor in neutral, engage the P.T.O. to start the pump. Adjust the R.P.M.'s to normal operating speed.
6. Increase pressure by turning Pressure Control Valve **1** (Fig. 15) clockwise. Adjust until the pressure gauge **3** (Fig. 15) reaches the desired pressure (turn Pressure Control Valve counter clockwise to decrease pressure).

### Operating the Spraygun (optional)

7. Set the three distribution valves **2** (Fig. 15) to the OFF position. Set spraygun valve **5** (Fig. 15) to the ON position.
8. Then depress the red handle **A** (Fig. 16) to spray fluid from the spraygun. Check the pressure on the system pressure gauge **3** (Fig. 15) and follow step **6** to adjust.
9. To adjust the spray pattern, turn the black handle **B** (Fig. 16) OUT for a narrow spray pattern for long distances and IN for a wide pattern for more coverage at close distances.

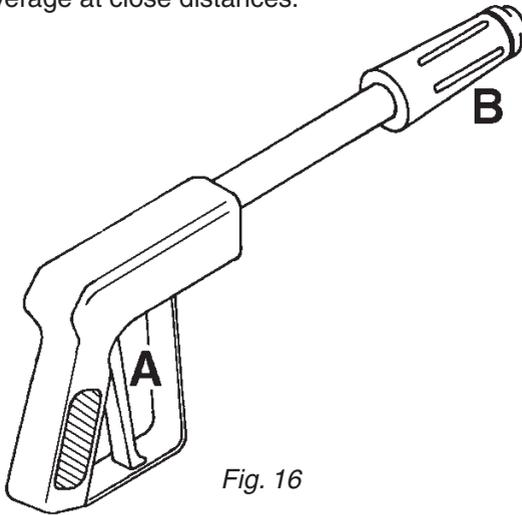

Fig. 16

### Agitation Adjustment

Agitation is necessary to keep the solution in your tank properly mixed. Consult your chemical supplier for the recommended amount of agitation.

In general, maximum agitation is required but some products tend to foam easily. To reduce foaming in some instances anti-foaming agents may be added to the tank (Refer to chemical label). When running low liquid levels in the tank, agitation may be reduced to facilitate pump priming and avoid pressure fluctuations. Make sure that you have adjusted the agitation properly before sprayer calibration.

Turn the agitation valve **4** (Fig. 15) clockwise to reduce the agitation flow. Turn the valve counter-clockwise to increase the agitation flow.



## 4.8 ET-1 Manual Control Plumbing Diagram

Review and study the following diagram. By following the flow through the diagram, you will better understand the various functions of your sprayer system.

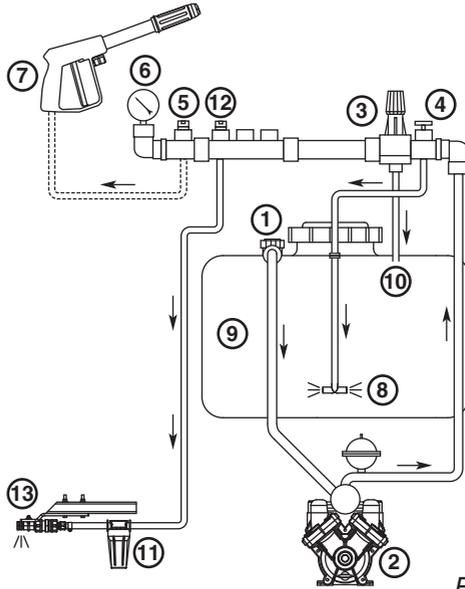

Fig. 17

- |                              |                               |
|------------------------------|-------------------------------|
| 1. Top Suction               | 8. Agitation                  |
| 2. Diaphragm Pump            | 9. Tank                       |
| 3. Pressure Control Valve    | 10. Bypass Return             |
| 4. Agitation Valve           | 11. In-Line Filter (optional) |
| 5. Spraygun Valve (optional) | 12. Boom Distribution Valve   |
| 6. System Pressure Gauge     | 13. Pasture Sprayer Nozzle    |
| 7. Spraygun (optional)       |                               |

## 4.9 Adjustment of the ET-1 Manual Controls

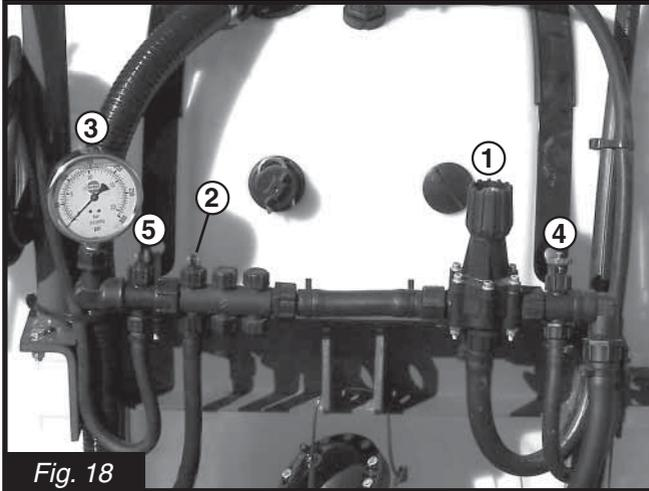
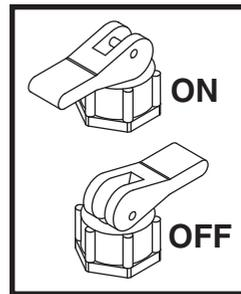

Fig. 18

1. Pressure control valve
2. Distribution valve
3. System pressure gauge
4. Agitation valve
5. Spraygun valve (optional)



### Operating the Pasture Sprayer Nozzle

1. Choose the desired pressure for your pasture sprayer (Section 5.2).
2. Locate your sprayer in a suitable location to spray water from the boom. Fill the tank with clean water (see section 4.1).
3. Turn Pressure Control Valve **1** (Fig. 18) counter clockwise all the way.
4. Set the distribution valve **2** (Fig. 18) to the ON position. Set spraygun valve **5** (Fig. 18) to the OFF position.
5. With the tractor in neutral, engage the P.T.O. to start the pump. Adjust the R.P.M.'s to normal operating speed.
6. Increase pressure by turning Pressure Control Valve **1** (Fig. 18) clockwise. Adjust until the pressure gauge **3** (Fig. 18) reaches the desired pressure (turn Pressure Control Valve counter clockwise to decrease pressure).



### Operating the Spraygun (optional)

7. Set the distribution valve **2** (Fig. 18) to the OFF position. Set spraygun valve **5** (Fig. 18) to the ON position.
8. Then depress the red handle **A** (Fig. 19) to spray fluid from the spraygun. Check the pressure on the system pressure gauge **3** (Fig. 18) and follow step **6** to adjust.
9. To adjust the spray pattern, turn the black handle **B** (Fig. 19) OUT for a narrow spray pattern for long distances and IN for a wide pattern for more coverage at close distances.

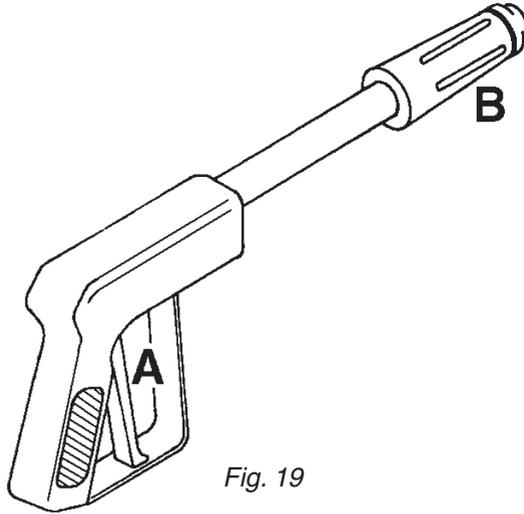

Fig. 19

### Agitation Adjustment

Agitation is necessary to keep the solution in your tank properly mixed. Consult your chemical supplier for the recommended amount of agitation.

In general, maximum agitation is required but some products tend to foam easily. To reduce foaming in some instances anti-foaming agents may be added to the tank (Refer to chemical label). When running low liquid levels in the tank, agitation may be reduced to facilitate pump priming and avoid pressure fluctuations. Make sure that you have adjusted the agitation properly before sprayer calibration.

Turn the agitation valve **4** (Fig. 18) clockwise to reduce the agitation flow. Turn the valve counter-clockwise to increase the agitation flow.

## 4.10 BK-3 Manual Control Plumbing Diagram

Review and study the following diagram. By following the flow through the diagram, you will better understand the various functions of your sprayer system.

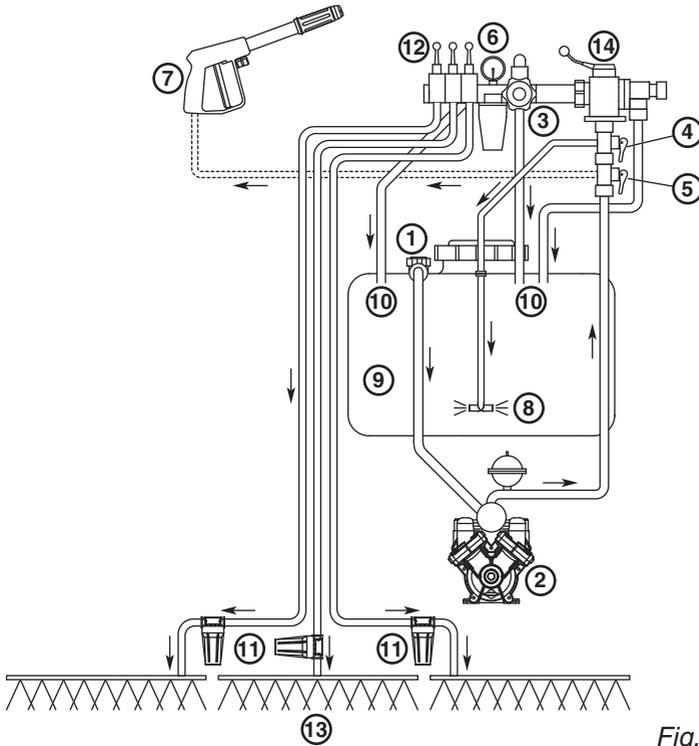

Fig. 20

- |  |   |
|--|---|
| 1. Top Suction                         | 8. Agitation  |
| 2. Diaphragm Pump                      | 9. Tank   |
| 3. HARDI-MATIC                         | 10. Bypass Returns                                      |
| 4. Agitation Valve                     | 11. In-Line Filters (optional)                          |
| 5. Spraygun Valve (optional)           | 12. Boom Distribution Valves with pressure equalization |
| 6. Pressure Filter with pressure gauge | 13. Boom  |
| 7. Spraygun (optional)                 | 14. On/Off Valve  |



## 4.11 Adjustment of the BK-3 Manual Controls

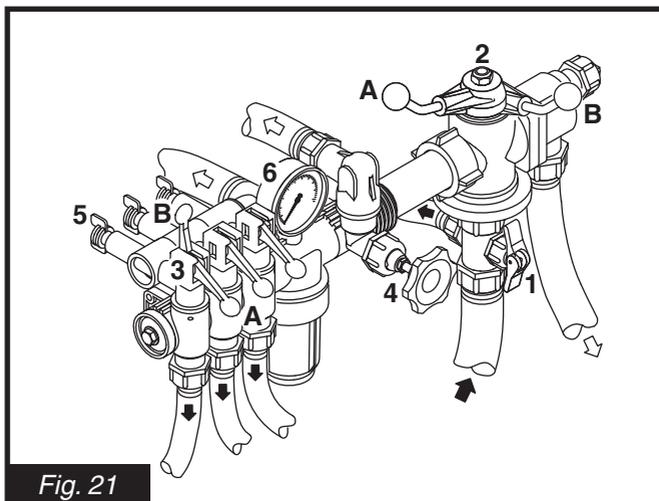

Fig. 21

1. Choose the correct nozzle. Make sure that all nozzles are the same type and capacity. Refer to section 5.0 for nozzle selection and calibration.
2. Locate your sprayer in a suitable location to spray water from the boom. Fill the tank with clean water (see section 4.1).
3. Open or close lever 1 (Fig. 21) depending on whether pressure agitation is required (Remember pressure agitation takes 5% to 10% of pump output).
4. Turn main On/Off handle 2 (Fig. 21) to **ON** position **A**.
5. Set all hand levers 3 (Fig. 21) on the distribution valves to **ON** position **A**.
6. Turn the HARDI-MATIC valve 4 (Fig. 21) counter-clockwise all the way out.
7. With the tractor in neutral, engage the P.T.O. to start the pump. Adjust the R.P.M.'s to normal operating speed.

**Note:** The P.T.O. revolutions must be kept between 300-600 R.P.M. for the HARDI-MATIC to function properly.

8. Increase pressure by turning the HARDI-MATIC valve 4 (Fig. 21) clockwise. Adjust until the pressure gauge 6 (Fig. 21) reaches the desired pressure (turn HARDI-MATIC valve counter clockwise to decrease pressure).



## Adjustment of Pressure Equalization

**Note:** Adjust the constant boom section pressure one section at a time as follows: (Start with the valve turned closed before adjusting).



9. Place the first boom distribution valve lever **3** (Fig. 21) in the **OFF** position **B**.
10. Turn the adjusting screw **5** (Fig. 21) until the pressure gauge **6** (Fig. 21) again shows the same pressure as in step **8** (Turn the screw clockwise for higher pressure, counter clockwise for lower pressure).
11. Turn the boom distribution valve lever **3** (Fig. 21) back to the **ON** position **A**.
12. Repeat steps **9** through **11** for the remaining boom section valves.

**Note:** Hereafter adjustment of the constant boom pressure will only be needed if you change to nozzles with other capacities, but not required if only changing pressure or application rate using the same nozzles.

## Operating the Control Unit while driving

13. In order to shut off the entire boom, turn the **ON/OFF** handle **2** (Fig. 21) to **OFF** position **B**. This returns the pump output to the tank through the return system. The diaphragm anti-drip valves ensure instantaneous closing of all nozzles.

In order to shut off one or more boom sections, turn the boom distribution lever(s) **3** (Fig. 21) of the unneeded boom section(s) to **OFF** position **B**. The constant pressure device ensures that the pressure does not increase in the section(s) which are still operating.



### Operating the Spraygun (optional)

14. Set the three distribution valves **3** (Fig. 21) to the OFF position. Set spraygun valve **5** (Fig. 20) to the ON position.
15. Then depress the red handle **A** (Fig. 22) to spray fluid from the spraygun. Check the pressure on the system pressure gauge **6** (Fig. 21) and follow step **8** to adjust.
16. To adjust the spray pattern, turn the black handle **B** (Fig. 22) OUT for a narrow spray pattern for long distances and IN for a wide pattern for more coverage at close distances.

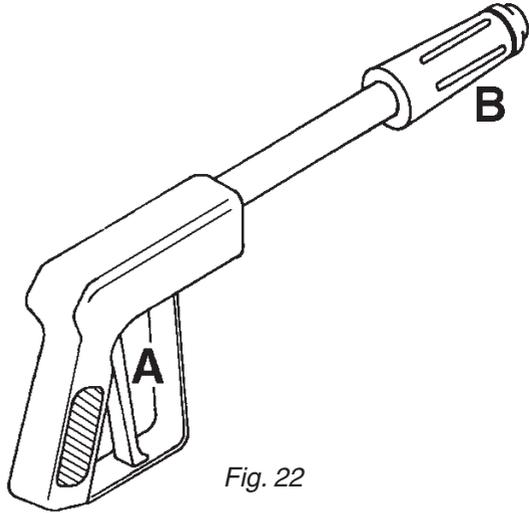

Fig. 22

## 4.12 Operation Of The Tank Drain Valve (all models)

**WARNING: BEFORE USING THE TANK DRAIN, VERIFY THAT DISPOSAL OF WASTE IS DONE ACCORDING TO CHEMICAL LABEL INSTRUCTIONS AND LOCAL REGULATIONS.**

The HARDI® N-series 3-PT sprayer is equipped with a top operated tank drain valve.

The top operated tank drain valve handle is located near the tank lid. To open the drain valve, turn the red drain valve handle (Fig. 23) counter-clockwise.

To close the drain valve, turn the handle (Fig. 23) clockwise.

### TOP OPERATED TANK DRAIN

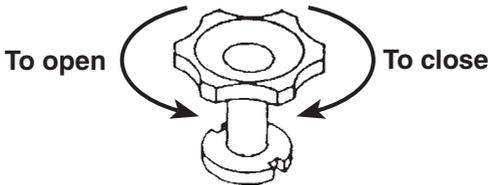

Fig. 23

## 4.13 Adjustment of Air Pressure in Pressure Damper (All models)

The air pressure in the damper on the HARDI® diaphragm pump is factory preset at 30 psi (2 bar). This is suitable for nozzle spray pressures between 45 psi (3 bar) and 225 psi (15 bar). If different nozzle pressures are required, set pressure damper at pressures indicated.

	
PSI (BAR)	PSI (BAR)
20-45 (1-3)	0-15 (0-1)
45-255 (3-15)	15-45 (1-3)





## 4.14 Unfolding/Folding Boom (All models with standard booms) Unfolding boom into operating position

1. Remove transport lock pin **A** (Fig. 24) and swing boom into operating position. Store transport lock pin in original location so it doesn't get lost.
2. Lift outer boom sections up and over to horizontal position (not necessary for 20' MB boom). Carefully check that feed hoses do not interfere with spray pattern.

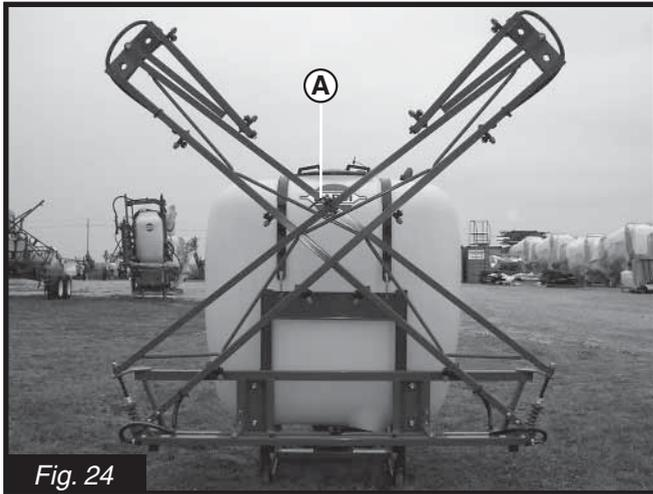

Fig. 24

### Folding boom into transport position

1. Fold outer boom section over to rest on inner boom section (not necessary for 20' MB boom).
2. Remove transport lock pin **A** (Fig. 24) and fold boom into transport position. Secure with transport lock pin **A** (Fig. 24).



**WARNING: MAKE ABSOLUTELY CERTAIN BOOM TRANSPORT LOCK PINS ARE INSTALLED AND SECURED WITH CLIP PINS BEFORE TRANSPORTING THE SPRAYER.**

## 4.15 Boom Height Adjustment (All models with standard booms)

Correct boom height is very important in order to achieve the most optimal spray pattern. Small adjustments of the boom height can usually be made with the 3-point suspension from the tractor - raising or lowering the sprayer.

In crops where greater adjustments are needed, the boom height can be changed manually by removing the 4 bolts holding the boom to the frame.

**Note:** This is best done by 2 people or with a mechanical hoist.



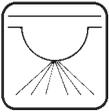

## 5.0 NOZZLE SELECTION

Correct selection of nozzles and calibration of the sprayer are critical to achieve accurate and cost effective use of farm crop protection products.

Your HARDI® N-series sprayer has been supplied with standard nozzles. Should you wish a different application rate or different type of nozzle, HARDI® manufactures a nozzle for virtually every need.



**IMPORTANT: Always consult your chemical supplier for recommended chemical rate and water application rate. Always wear protective gloves when handling nozzles.**

### 5.1 Boom Nozzle Selection (All models with standard booms)

The following tables show what types of spray nozzles are suitable for different applications. It is important to use the correct nozzle.

	<p><b>HARDI® ISO COLOR TIPS™</b> 110 degree flat fan, one piece cap and nozzle; color coded for flow rate selection. For herbicides, insecticides, and fertilizer applications. 50, 80, and 100 mesh screens are normally used.</p>	F110
	<p><b>HARDI® ISO LowDrift COLOR TIPS™</b> 110 degree flat fan, one piece cap and nozzle, 1553 solid stream nozzle; color coded for flow rate selection. In-Line Filters will normally be used.</p>	LD110

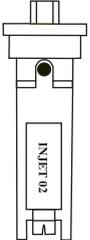
	<p><b>HARDI® INJET™ NOZZLES;</b> air inclusion nozzles with removable restrictor. Color coded for flow rate selection. In-Line Filters will normally be used.</p>	
	<p><b>FLAT SPRAY NOZZLES</b> in 65 degree, 80 degree, and 110 degree spray angles. For herbicides, insecticides, and fertilizer applications. 50, 80, and 100 mesh screens are normally used.</p>	<p>4665-65 degree 2080-80 degree 4110-110 degree</p> <p>Part # 330013-O-ring</p>
	<p><b>FLOOD NOZZLES</b> set at 40° spacing. Designed for high volume application.</p>	<p>4598</p>
	<p><b>HOLLOW CONE NOZZLES</b> for high pressure and high volume insecticide application in row crops. 1553 nozzles are ALWAYS used with swirl plates shown below EXCEPT when used as solid stream nozzles. 50, 80, or 100 mesh screens are normally used with these nozzles</p>	<p>1553 Must add swirl to produce hollow cone pattern</p>
	<p><b>SWIRL PLATE</b> used in conjunction with cone nozzle to create desired spray pattern. These swirls work with 1553 series cone nozzles. Grey, blue, or black swirls are used to create hollow cone effect. White swirls are used to create full cone effect.</p>	<p>Grey Blue Black White</p>

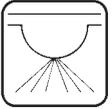

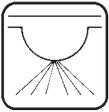

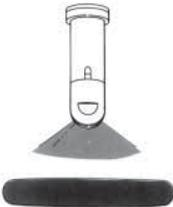
	<p><b>HOLLOW CONE CERAMIC NOZZLES</b> for high pressure and high volume fungicide and insecticide application.</p>	<p>1299</p>
	<p><b>LARGE DROPLET HOLLOW CONE NOZZLE</b> for use where drift must be kept to a minimum. These nozzles must always be fitted with 1553 nozzles and grey swirl plates. 50, 80 or 100 mesh screens are normally used with these nozzles.</p>	<p>371077</p>
	<p><b>LARGE DROPLET FLAT SPRAY TIP IN 150 DEGREE SPRAY ANGLE.</b> Always used in conjunction with 1553-14-16-18 or 20 cone nozzle. 50, 80 or 100 mesh screens are normally used with these nozzles.</p>	<p>371551</p>
	<p><b>SOLID STREAM NOZZLE</b> for high volume liquid fertilizer application. In this application, the 1553 nozzle is always used with 330013 o-ring and 50, 80 or 100 mesh screens.</p>	<p>1553 less swirl</p>
	<p><b>HARDI® QUINTASTREAM 5 HOLE LIQUID FERTILIZER NOZZLE</b> Five streams of liquid are distributed at different angles and flows. Highest flow is from the middle stream and lowest in the outer; overlapping streams. This allows for boom movements that do not influence distribution. Boom heights of 20" can be used as safely as 30".</p>	<p>372011 thru 372019</p>



## 5.2 Brass Boomless Nozzle (Pasture Sprayer only)

The pasture sprayer model uses a single brass nozzle to provide a maximum spray width of 52' (16m) under optimal spraying conditions at the recommended 24"-48" (61-122 cm) nozzle spray heights. A single brass nozzle includes 2 interchangeable caps for 90° & 180° spraying. Use 90° spraying to avoid fences or trees. Use 180° spraying for full coverage in open areas.

### Brass Boomless Nozzle characteristics:

- 90° & 180° spraying
- Pressure range: 30 to 60 PSI
- Spray width up to 52 ft.
- Brass for increased wear resistance

**IMPORTANT: Always consult your chemical supplier for recommended chemical rate and water application rate. Always wear protective gloves when handling nozzles.**

Use the following table to quickly determine which pressure and speed will work best for a wide range of application rates.

**Note:** Using this chart will get you close to your desired application rate. However, you must calibrate your sprayer with clean water before applying chemicals (Section 5.5).

GPA for 180° #10 Brass Boomless Nozzle*							
PSI	GPM	SWATH	3 mph	4 mph	5 mph	8 mph	10 mph
30	3.7	50'	12.0	9.2	7.3	4.6	3.7
40	4.2	50'	13.9	10.4	8.3	5.2	4.2
50	4.6	52'	14.6	10.9	8.8	5.5	4.4
60	5.0	52'	15.8	11.9	9.5	5.9	4.8

\* 90° nozzle has same GPA, but 1/2 GPM & swath

Fig. 25

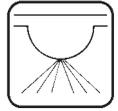

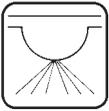

### 5.3 Spraygun Nozzle Selection (All models)

The 1099-20 nozzle (HARDI® ref. no. 371314) is the standard nozzle for the spraygun. This nozzle supplies the following rates in U.S. gallons per minute at the given pressures:

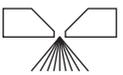
NOZZLE	PSI	GPM	
			
1099-20	20	0.678	0.538
	30	0.829	0.661
	40	0.956	0.766
	50	1.068	0.857
	60	1.169	0.940
	70	1.261	1.018
	100	1.504	1.222
	150	1.840	1.500
200	2.123	1.736	

Other size 1099 nozzles are available from your HARDI® Dealer.

## 5.4 Calibration (All models with standard booms)

**WARNING: ALWAYS CALIBRATE YOUR SPRAYER WITH CLEAN WATER ONLY! IN ADDITION, WEAR PROTECTIVE CLOTHING WHEN CALIBRATING YOUR SPRAYER!**



### Why must you calibrate a sprayer?

A nozzle selection chart will tell you what application rate you should expect. Variations due to nozzle wear, errors in pressure adjustment, and tractor speedometer can result in a possible error in application rate.

### How do you calibrate a sprayer?

Calibration kits are available from HARDI®, #81624503 for US gallons & #81859600 for metric calibration.

Following are some tips to remember when using the calibration kit method:

- When determining the length of time required to drive the recommended distance, drive in actual field conditions with a half-full tank.
- Repeat the test several times, each time avoiding the tracks from the previous test. Take the average of the times recorded.
- Calibration of the sprayer should be completed at the beginning of the season and repeated after every 2 to 3 full days of spraying, and every time you change volume rate or use new nozzles.
- Before you calibrate, check the flow of each nozzle. If it puts out more than 10% of its original volume, replace it.

Select your calibration method: Ounce method or Formula method. Then follow the steps described in the corresponding section(s):



## Ounce Method

1. Determine how long it takes to cover the test strip. Use the following chart to determine the length of your test strip. Row width for broadcast application is equal to your nozzle spacing. For your drop nozzle or band application, use row spacing.

<u>Row width or nozzle spacing (in.)</u>	<u>Distance (ft.)</u>
40	102
38	107
36	113
34	120
32	127
30	136
28	146
26	157
24	170
22	185
20	204
18	227
16	255
14	291

2. Measure the amount of time it takes you to travel the test strip when throttle is set at spraying speed.
3. In a container (with oz. measurements), catch the spray from one nozzle for that amount of time. For drop or band nozzles, catch the spray from all nozzles for the row.
4. Read the ounces in the container. That is the actual U.S. GPA applied. (ounces = GPA)

## Formula Method

1. Check your spraying speed. Measure a test strip of at least 200 feet (300 feet is ideal). Travel the distance at the speed you plan on spraying and record the time it takes to travel the distance. Read from the chart or use the formula to find your exact travel speed.



### Travel Time (in seconds)

	Speed in MPH	200 ft.	300 ft.
	3.0	45	68
	3.5	39	58
	4.0	34	51
	4.5	30	45
	5.0	27	41
	6.0	23	34
	7.0	19	29
	7.5	18	27
	8.0	17	26
	9.0	15	23

#### Formula:

$$\frac{\text{distance (ft.)} \times 0.68}{\text{seconds}} = \text{MPH}$$

#### Formula:

$$\text{GPM} = \frac{10 \times 7 \times 20}{5940} = .24 \text{ GPM}$$

- Note:** W=
- Nozzle spacing (in inches) for broadcast application.
  - Row spacing (in inches) divided by number of nozzles per row for drop nozzle application.
  - Sprayed band width or swath width (in inches) for band application divided by number of nozzles per band.
  - Note that on the nozzle wheel, W = 20 inches.

3. Set correct pressure. Read the required pressure from the nozzle table in the nozzle catalogue or nozzle wheel. With clean water in the tank and line, turn on the sprayer and set the target pressure. Collect the spray from one nozzle for one minute in a container. Adjust pressure until you collect the precise GPM called for.



### Calibration For Carriers Other Than Water

Use the following water rate conversion chart to determine the right conversion factor. When you've determined the new converted GPM or GPA, you can follow the steps on either the pressure or ounce method of calibration.

<u>Weight of solution</u>	<u>Specific Gravity</u>	<u>Conversion Factors</u>
7.00 lbs/gal	.84	.92
8.00 lbs/gal	.96	.98
8.34 lbs/gal-water	1.00	1.00
9.00 lbs/gal	1.08	1.04
10.00 lbs/gal	1.20	1.10
10.65 lbs/gal-28% N	1.28	1.13
11.00 lbs/gal	1.32	1.15
12.00 lbs/gal	1.44	1.20
14.00 lbs/gal	1.68	1.30

Example:            20 GPA of 28% N  
                           Then GPA (solution) x conversion factor = GPA (water)  
                           20 GPA (28% N) x 1.13 = 22.6 GPA (water)  
                           Calibrate for 22.6 GPA of water

For conversion to Imperial gallons per acre, multiply U.S. GPA by .833

For conversion to liters per hectare, multiply U.S. GPA by 9.34

For conversion to liters per acre, multiply U.S. GPA by 3.78

Formula for tractor speed:  $\frac{\text{Distance (in feet)}}{\text{Second}} \times .682 = \text{MPH}$

## 5.5 Calibration (Pasture sprayer model only)

**WARNING: ALWAYS CALIBRATE YOUR SPRAYER WITH CLEAN WATER ONLY! IN ADDITION, WEAR PROTECTIVE CLOTHING WHEN CALIBRATING YOUR SPRAYER!**



### Why must you calibrate a sprayer?

A nozzle selection chart will tell you what application rate you should expect. Variations due to nozzle wear, errors in pressure adjustment, and tractor speedometer can result in a possible error in application rate.

### How do you calibrate a sprayer?

Calibration kits are available from HARDI®, #81624503 for US gallons & #81859600 for metric calibration.

Following are some tips to remember when using the calibration kit method:

- When determining the length of time required to drive the recommended distance, drive in actual field conditions with a half-full tank.
- Repeat the test several times, each time avoiding the tracks from the previous test. Take the average of the times recorded.
- Calibration of the sprayer should be completed at the beginning of the season and repeated after every 2 to 3 full days of spraying, and every time you change volume rate or use new nozzles.
- Before you calibrate, check the flow of the nozzle. If it puts out more than 10% of its original volume, replace it.



## Formula Method

1. Choose your application rate according to the recommendations on the chemical container. For 180° #10 Brass Boomless Nozzles, use the nozzle chart on page 39 (Fig. 25) to find the closest desired pressure and speed to match the application rate.
2. Use the following formula to calculate the nozzle capacity:

### Formula:

$$\text{Total GPM} = \frac{W \text{ (ft.)} \times \text{GPA} \times \text{MPH}}{495}$$

**Note:** W = Total measured sprayed width (ft.) at operating pressure.

3. To initially calculate GPM, let W = 50 ft. or 52 ft. depending on the pressure selected from the chart on page 39 (Fig. 25).

Example:            Total sprayed width: 50 ft. (40 PSI)  
                           Application rate: 10 GPA (Closest from chart 10.4)  
                           Forward speed: 4 mph

$$4.04 \text{ GPM} = \frac{50 \text{ ft.} \times 10 \text{ GPA} \times 4 \text{ mph}}{495}$$

4. Check your spraying speed. Measure a test strip of at least 200 feet (300 feet is ideal). Travel the distance at the speed you plan on spraying and record the time it takes to travel the distance. Read from the chart or use the formula to find your exact travel speed.

### Travel Time (in seconds)

	Speed in MPH	200 ft.	300 ft.
	3.0	45	68
	4.0	34	51
<b>Formula:</b>	5.0	27	41
$\frac{\text{Distance (ft.)} \times 0.68}{\text{Time (sec.)}} = \text{MPH}$	6.0	23	34
	7.0	19	29
	8.0	17	26
	9.0	15	23
	10.0	14	20



## Calibration (continued)

5. If the measured sprayed width at operating pressure differs from the value used in step 2, re-calculate the nozzle capacity using the measured sprayed width. This will be the corrected nozzle capacity in GPM required for proper application rate.

**IMPORTANT:** *Always check actual sprayed width at operating pressure once the correct nozzle has been chosen. Locate the sprayer in a suitable location and use clean water to check.*

6. Double-check the nozzle output with a measuring jug (using clean water at operating pressure). If the measured nozzle output matches the required calculated output, calibration is complete.
7. If necessary, use the following formulas to adjust either the spraying speed or operating pressure to achieve proper calibration.

$$\text{New speed (MPH)} = \frac{\text{Desired output (GPM)} \times \text{Previous speed (MPH)}}{\text{Measured output (GPM)}}$$

$$\text{New pressure (PSI)} = \frac{\text{Desired output (GPM)} \times \text{Previous pressure (PSI)}}{\text{Measured output (GPM)}}$$

**Note:** If the operating pressure is changed, the actual spraying width will need to be checked again. If spraying width differs, repeat steps 5-7.

**Note:** When calibrating with 90° spraying cap, use 1/2 the spraying width to begin calculations.

Example:            Total sprayed width: 25 ft. (40 PSI)  
                         Application rate: 10 GPA (Closest from chart 10.4)  
                         Forward speed: 4 mph

$$2.02 \text{ GPM} = \frac{50 \text{ ft.} \times 10 \text{ GPA} \times 4 \text{ mph}}{495}$$





### Calibration For Carriers Other Than Water

Use the following water rate conversion chart to determine the right conversion factor. When you've determined the new converted GPM or GPA, you can follow the steps in the formula method of calibration.

<u>Weight of solution</u>	<u>Specific Gravity</u>	<u>Conversion Factors</u>
7.00 lbs/gal	.84	.92
8.00 lbs/gal	.96	.98
8.34 lbs/gal-water	1.00	1.00
9.00 lbs/gal	1.08	1.04
10.00 lbs/gal	1.20	1.10
10.65 lbs/gal-28% N	1.28	1.13
11.00 lbs/gal	1.32	1.15
12.00 lbs/gal	1.44	1.20
14.00 lbs/gal	1.68	1.30

Example:            20 GPA of 28% N  
                          Then GPA (solution) x conversion factor = GPA (water)  
                          20 GPA (28% N) x 1.13 = 22.6 GPA (water)  
                          Calibrate for 22.6 GPA of water

For conversion to Imperial gallons per acre, multiply U.S. GPA by .833

For conversion to liters per hectare, multiply U.S. GPA by 9.34

For conversion to liters per acre, multiply U.S. GPA by 3.78

Formula for tractor speed:  $\frac{\text{Distance (in feet)}}{\text{Second}} \times .682 = \text{MPH}$

## 6.0 MAINTENANCE

**IMPORTANT:** *Always clean the sprayer at the end of your workday or before servicing is done to avoid unnecessary contact with chemicals.*

In order to derive full benefit from the sprayer for many years, the following few, but important rules should be followed.

### 6.1 Cleaning The Sprayer

#### Guidelines

Read the whole label for the chemical used. Take note of any particular instructions regarding recommended protective clothing, deactivating agents, etc. Read the detergent and deactivating agent labels. If cleaning procedures are given, follow them closely.

Be familiar with local legislation regarding disposal of pesticides washings, mandatory decontamination methods, etc. Contact the appropriate body (e.g. Dept. of Agriculture).

Cleaning starts with calibration, as a well calibrated sprayer will ensure a minimal amount of remaining spray liquid.

It is good practice to clean the sprayer immediately after use, thereby rendering the sprayer safe and ready for the next application. This also prolongs the life of the components.

It is sometimes necessary to leave spray liquid in the tank for short periods - overnight, or until the weather becomes suitable for spraying again. Unauthorized persons and animals must not have access to the sprayer under these circumstances.

If the product applied is corrosive, it is recommended to coat all metal parts of the sprayer before and after use with a suitable rust inhibitor.

Remember: Clean sprayers are safe sprayers.  
Clean sprayers are ready for action.  
Clean sprayers can not be damaged by chemicals and their solvents.





## Cleaning

1. Dilute remaining spray liquid in the tank with at least 10 parts water and spray the liquid out in the field you have just sprayed.

**Note:** It is advisable to increase the forward speed (double if possible) and reduce the pressure.

2. Select and use the appropriate protective clothing. Select detergent suitable for cleaning and suitable deactivating agents if necessary.
3. Rinse and clean sprayer and tractor externally. Use detergent if necessary.
4. Remove all filters and clean them. Be careful not to damage the mesh. Replace filters when the sprayer is completely clean.
5. With the pump running, rinse the inside of the tank. Remember the tank roof. Rinse and operate all components and any equipment that has been in contact with the chemical.
6. After spraying the liquid out again in the field, stop the pump and fill at least 1/5 of the tank with clean water. Note that some chemicals require the tank to be completely filled. Add appropriate detergent and/or deactivating agent, e.g. Washing soda or Triple ammonia.

**Note:** If a cleaning procedure is given on the chemical label, follow it closely.

7. Start the pump and operate all controls enabling the liquid to come in contact with all the components. Leave the distribution valves until last. Some detergents and deactivating agents work best if left in the tank for a short period. Check the label.
8. Drain the tank and let the pump run dry. Rinse inside of tank, again letting the pump run dry.
9. Stop the pump. If the chemicals used have a tendency to block nozzles, remove and clean them now.
10. Replace all filters and nozzles and store the sprayer. If, from previous experiences, it is noted that the solvents in the chemicals are particularly aggressive, store the sprayer with the tank lid open.

**Note:** If the sprayer is cleaned with a high pressure cleaner we recommend lubrication of the entire machine (Section 6.8).

## 6.2 Filters

**IMPORTANT:** *Wear protective clothing when servicing & handling components that have been in contact with spray liquid.*

Clean filters ensure :

- Sprayer components such as valves, diaphragms and operating unit are not hindered or damaged during operation.
- Nozzle blockages do not occur while spraying.
- Long life of pump. A blocked suction filter will result in pump cavitation.

### Suction filter

The main filter protecting sprayer components is the suction filter at the top of the tank. Check it regularly. Make sure the O-ring on the filter housing is in good condition and lubricated\*.

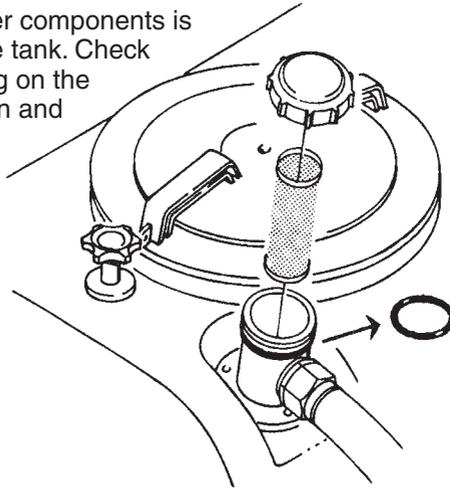

### Pressure filter (BK-3 Control Unit only)

The BK-3 Control unit is equipped with a built-in pressure filter. Unscrew the base to check and clean the filter. Make sure the O-ring on the filter housing is in good condition and lubricated\*.

\*HARDI® recommends using a silicone based lubricant to prolong the life of the O-ring.



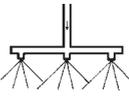

ISO Nozzle Size 	Suction Filter 	Nozzle Screen 	Inline Filters (optional) 
Pink (075) Orange (01) Green (015) Yellow (02)	50	100	100
Lilac (025) Blue (03)	50	80	80
Red (04) & Larger	30*	50*	50*

\*Standard mesh

### 6.3 Nozzles And Fittings

Poor seals are usually caused by:

- Missing O-rings or gaskets
- Damaged or incorrectly seated O-rings
- Dry or deformed O-rings or gaskets
- Foreign materials

Therefore, in case of leaks; **DO NOT** over tighten. Disassemble, check condition and position of O-ring or gasket, clean, lubricate and reassemble. For **radial** type seals (O-ring) hand tighten only, do not use pliers (Fig. 26).

The O-rings need to be lubricated **ALL THE WAY AROUND** before fitting on to the nozzle tube.



Fig. 26

HARDI® recommends using a silicone based lubricant to prolong the life of the O-ring.

## 6.4 Changing the Valves and Diaphragms (all pumps)

**Note:** It is recommended that if one or more diaphragms and or valves need replacing, they should all be replaced. Complete rebuild kits are available from HARDI® (check the table below for part numbers).



Pump model	603	1203	1303
Hardi® Part No.	75073200	75073400	75073600

1. Remove the valve cover **1**. Before changing the valves **2**, note the orientation of the valves so that they are replaced correctly.
2. It is recommended to use new O-rings **3** when changing or checking valves.
3. Remove diaphragm covers **4** to gain access to the diaphragms.
4. Remove the diaphragm bolts **5**. The diaphragms **6** may now be changed.
5. If fluids have reached the crankcase, regrease the pump thoroughly. Also make sure the drain hole at the bottom of the pump is not blocked.
6. Reassemble with torque settings shown below.

Pump Model	Valve Cover Ft/lb (Nm)	Diaphragm Bolt Ft/lb (Nm)	Diaphragm Cover
603	34 (46)	18.5 (25)	37 (50)
1203/1303	45 (60)	45 (60)	50 (70)

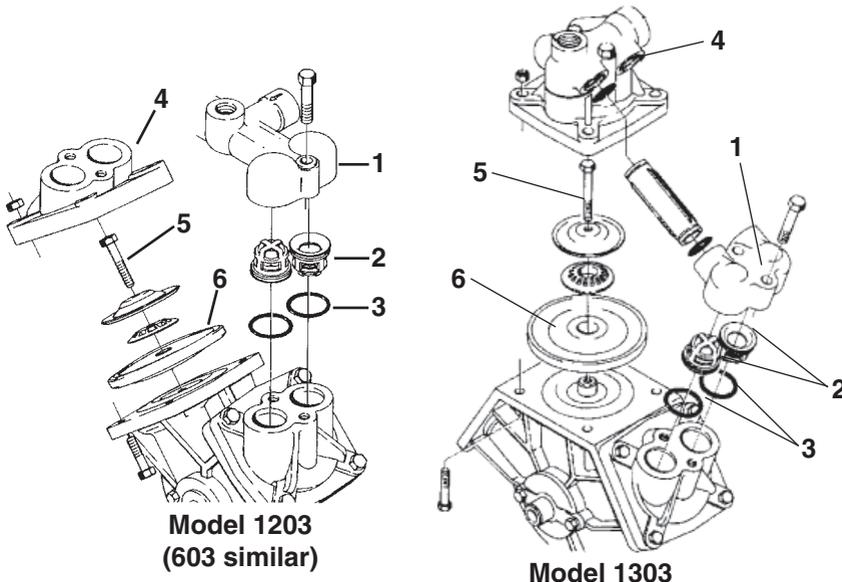



## 6.5 Lubrication

Recommended lubrication is shown in following tables.  
Use ball bearing grease (lithium grease No. 2)

**Note:** If the sprayer is cleaned with a high pressure cleaner or fertilizer has been used, we recommend lubrication of all sections.

**POS.**

Position on  
sprayer



Grease



Page to find more  
information



Oil



Operation  
hours



Winter protection  
or off-season  
storage

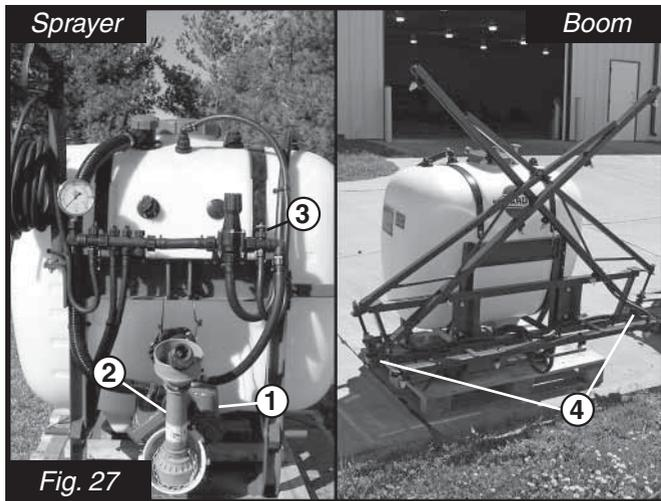

*N-series sprayer lubrication points*

1. Pump
2. PTO
3. Agitation Control
4. Clutch

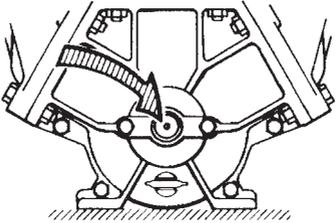
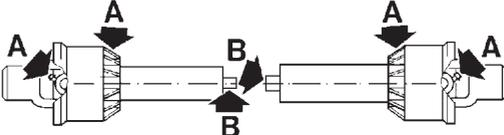
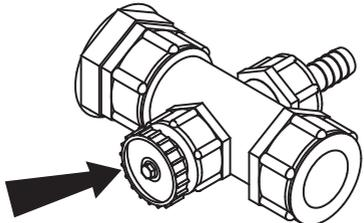

POS.					
1		X	40		53
2	A B	X X	10 50		
3	X		40		54



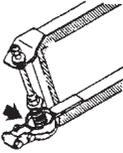

POS.					
4		X	8		54

## 7.0 Off-Season Storage

When the spraying season is over, you should devote some extra time to the Sprayer. If chemical residues are left over in the sprayer for long periods, it can reduce the life of the individual components. To preserve the sprayer and protect the components, carry out the following off-season storage program:



1. Clean the sprayer completely - inside and outside - as described under "Cleaning The Sprayer" (section 6.1). Make sure that all valves, hoses and auxiliary equipment have been cleaned with detergent and flushed with clean water afterwards, so no chemical residues are left in the sprayer.
2. Replace any damaged seals and repair any leaks.
3. Empty the sprayer completely and let the pump work for a few minutes. Operate all valves and handles to drain as much water out of the spraying circuit as possible. Let the pump run until air is coming out of all the nozzles.
4. Pour in a mixture of ethylene glycol base antifreeze and water at the ratio for the desired temperature protection (there will be a small amount of water left in the hoses, pump and bottom of tank). The volume of the mixture needs to be enough keep the tank sump full while the pump is running fluid through the entire circuit.
5. Engage the pump and operate all valves and functions of the plumbing system. Spray the spraygun (optional) into the tank until antifreeze sprays out to make sure the line is full of antifreeze. Open the distribution valves so the antifreeze is sprayed through the nozzles as well. The antifreeze will also prevent O-rings, seals, diaphragms etc. from drying out.
6. When the sprayer is dry, remove rust from any scratches or damages in the paint and touch up the paint.
7. Lubricate all lubricating points according to the lubricating scheme regardless of intervals stated.
8. Remove the glycerine-filled pressure gauge and store in a vertical position in frost free conditions.
9. Apply a thin layer of anticorrosive oil (e.g. SHELL ENSIS FLUID, CASTROL RUSTILLO or similar) on all metal parts. Avoid oil on rubber parts, hoses and tires.



## **Off-Season Storage (continued)**

10. All electric plugs and sockets are to be stored in a dry plastic bag to protect them from moisture, dirt, and corrosion.
11. Remove all the control boxes (including any rate controller control box) from the tractor and store them in a dry and clean place.
12. To protect against dust, the sprayer can be covered by a tarpaulin. Ensure ventilation to prevent condensation.

### **7.1 Preparation After Off-Season Storage**

After a storage period, the sprayer should be prepared for the next season the following way:

1. Remove the cover. (If fitted)
2. Fit the pressure gauge again. Seal with Teflon tape.
3. Connect the sprayer to the tractor, including electric controls (if any).
4. Empty the tank of remaining antifreeze.
5. Rinse the entire liquid circuit on the sprayer with clean water.
6. Fill with clean water and check all functions.

## 8.0 ACCESSORIES

### 8.1 Clean Water Dispenser (optional)



Fig. 28

*Clean Water Dispenser*

A handy source of fresh water on the sprayer to clean up plugged nozzles and for rinsing gloves and hands after performing service or maintenance.

### 8.2 Spraygun And Hose Wrap (optional)

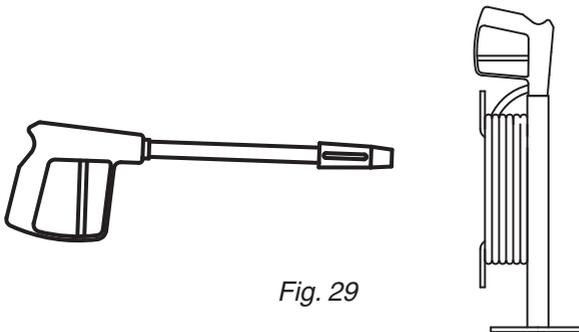

Fig. 29

A spraygun with adjustable spray pattern and 25 ft. of 3/8" hose for spraying fence row or spot spraying a small area can be installed onto your sprayer. A handy hose wrap and spraygun holder can be conveniently located on the sprayer to transport the spraygun. A Hose Reel with 150' of 1/2" hose\* is also available.

\* Not available on N210 with boom



### 8.3 SprayMate II Rate Controller (optional)



Fig. 30

The SprayMate II Rate Controller offers precise rate control regardless of field conditions. It is equipped with a Master control switch and built-in boom switches. It features on-the-go rate adjustment, push button auto/manual control for spot treatment, as well as a minimum flow feature to ensure proper application pattern as ground speed slows to extremes.

### 8.4 Large 4" Pressure Gauge (optional)



Fig. 31

A large and easy to read 4" pressure gauge is available to replace the standard 2-1/2" gauge.

## 8.5 Chemical Filler (optional)



*Fig. 32*

*Chemical Filler*

Will inject all types of chemical formulations, liquid, powder or granules, into the bottom of the tank near the agitation flow. A cleaning ring ensures that chemical residue is removed from the filler tank.

## 8.6 Chemical Filler Bag & Bottle Rinse Kit (optional)



*Fig. 33*

*Chemical Filler Bag & Bottle Rinse Kit*

A container rinse kit for liquid containers or plastic bags is also available for installation into the chemical filler hopper.



## 8.7 SMV Sign Kit (optional)

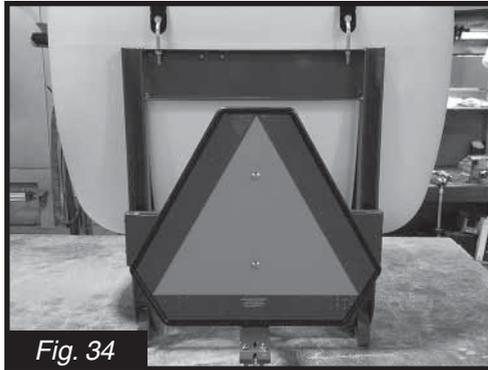

A kit is available to mount an SMV Sign to the nozzle bracket.



## 9.0 TROUBLESHOOTING

### 9.1 General Spray Systems



<b>Problem</b>	<b>Cause</b>
1. No liquid getting to the pump.	A. Suction filter plugged.
2. Lack of pressure	A. Suction filter plugged. B. P.T.O. speed not fast enough. C. Suction side air leak. D. Pump valves obstructed or worn. Replace valves if necessary (Section 6.4). E. Check pressure gauge.
3. Pressure jumping	A. Suction side air leak. B. P.T.O. shaft slipping on pump crank shaft. C. Suction filter partially plugged. D. Check pressure gauge.
4. Pressure dropping	A. P.T.O. shaft slipping on pump crank shaft. B. Suction side air leak. C. Suction filter partially plugged.
5. Control box not operating one or more boom sections	A. Check connections at battery. B. Check for blown inline fuse on power supply wiring harness. (7.5 Amp - Section 3.3) C. Check electrical wiring for bad connection. D. Check for 12 Volts at boom distribution valve solenoids.
6. Liquid leaking from pump	A. Damaged diaphragm(s). Replace (Section 6.4).
7. Poor agitation	A. Agitation valve not open. B. Agitation nozzle plugged. C. Agitation nozzle missing.



## 9.1 General Spray Systems (continued)

<b>Problem</b>	<b>Cause</b>
8. Excessive vibrations in hoses	A. P.T.O. shaft slipping on pump crank shaft. B. Suction side air leak.
9. Can't get tank empty.	A. Small tear or pin hole in suction tube. B. Tank is not level.

# 10.0 TECHNICAL SPECIFICATIONS

## 10.1 Dimensions and weights

The following charts give approximate dimensions and weights for the HARDI® N-series 3-PT sprayers. Since each sprayer can have many different options/configurations, these are only approximate. If more accurate results are needed, it is recommended to measure or weigh the sprayer before connecting it to the tractor.

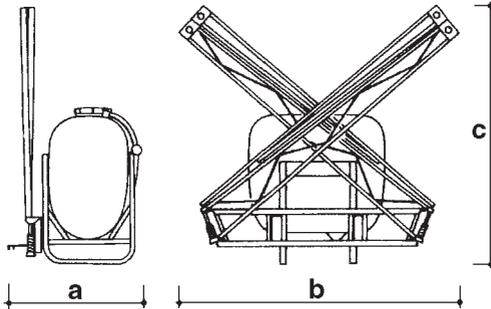
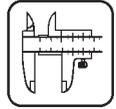

Tank size (Gal.)	With boom			Without boom		
	Dimensions a x b x c (inches)	Empty Weight (lbs.)	Loaded Weight* (lbs.)	Dimensions a x b x c (inches)	Empty Weight (lbs.)	Loaded Weight* (lbs.)
105	55 x 75 x 83	375	1251	28 x 39 x 52	250	1126
155	55 x 101 x 102	475	1768	31 x 47 x 55	300	1593
210	55 x 101 x 102	525	2276	31 x 63 x 57	350	2101

\*Total loaded weight with water. Some solutions may weigh more.

## 10.2 Power consumption

Minimum tractor requirements:

N105 ..... 40HP (30 kW)

N155 ..... 50HP (37 kW)

N210 ..... 60HP (45 kW)



## 11.0 WARRANTY POLICY AND CONDITIONS

HARDI® NORTH AMERICA INC. , 1500 West 76th Street, Davenport, Iowa, USA hereinafter called "HARDI®", offers the following limited warranty in accordance with the provisions below to each original retail purchaser of its own manufacturer, from an authorized HARDI® dealer that such equipment is at the time of delivery to such purchaser, free from defects in material and workmanship and that such equipment will be warranted for a period of one year from the time of delivery to the end user, providing the machine is used and serviced in accordance with the recommendations in the Operator's Manual and is operated under normal farm conditions.

1. This limited warranty is subject to the following exceptions:
  - a) Parts of the machine not manufactured by HARDI®, (i.e. engines, tires, tubes, electronic controls and other components or trade accessories, etc.) are not covered by this warranty but are subject to the warranty of the original manufacturer. Any claim falling into this category will be taken up with the manufacturer concerned.
  - b) This warranty will be withdrawn if any equipment has been used for purposes other than for which it was intended or if it has been misused, neglected, or damaged by accident, let out on hire or furnished by a rental agency. Nor can claims be accepted if parts other than those manufactured by HARDI® have been incorporated in any of our equipment. Further, HARDI® shall not be responsible for damage in transit or handling by any common carrier and under no circumstances within or without the warranty period will HARDI® be liable for damages of loss of use, or damages resulting from delay or any consequential damage.
2. We cannot be held responsible for loss of livestock, loss of crops, loss because of delays in harvesting or any other expense or loss incurred for labor, supplies, substitute machinery, rental for any other reason, or for injuries either to the owner or to a third party, nor can we be called upon to be responsible for labor charges, other than originally agreed, incurred in the removal or replacement of components.
3. The customer will be responsible for and bear the costs of:
  - a) Normal maintenance such as greasing, maintenance of oil levels, minor adjustments including the boom.
  - b) Transportation of any HARDI® product to and from where the warranty work is to be performed.
  - c) Dealer travel time to and from the machine or to deliver and return the machine from the service workshop for repair unless otherwise dictated by state law.
  - d) Dealer traveling costs.
4. Parts defined as normal wearing items, (i.e. Pump Diaphragms, Valves, O-rings, Tires and V-belts) are not in any way covered under this warranty.
5. This warranty will not apply to any product which is altered or modified without the express written permission of the HARDI® Service and Engineering Departments and/or repaired by anyone other than an Authorized HARDI® Dealer.
6. Warranty is dependent upon the strict observance by the purchaser of the following provisions:
  - a) That this warranty may not be assigned or transferred to anyone.
  - b) That the Warranty Registration Certificate has been correctly completed by dealer and purchaser with their names and addresses, dated, signed and returned to the appropriate address as given on the Warranty Registration Certificate within 30 days of delivery to the purchaser.
  - c) That all safety instructions in the operator's manual shall be followed and all safety guards regularly inspected and replaced where necessary.
7. No warranty is given on second-hand products and none is implied.

# WARRANTY POLICY AND CONDITIONS



8. Subject to the following terms, conditions and contributions, HARDI® extends the warranty on polyethylene tanks (excluding fittings, lids and gaskets) to FIVE YEARS on field sprayers. To qualify for this extended warranty, the tank must be drained and flushed with fresh water after each day's use. HARDI®'s liability is limited to replacement of defective parts FOB our plant in Davenport, IA at no cost to the purchaser for the first twelve months after date of purchase; at 20% of the then current retail price during the second year; at 40% during the third year; at 60% during the fourth year; and at 80% during the fifth year. This extended warranty is subject, in each instance, to the tank being inspected and approved for replacement or repair by HARDI® personnel before HARDI® will accept any liability hereunder.
9. Subject to the following terms, conditions and contributions, HARDI® extends the warranty on HARDI® diaphragm pumps (excluding wearing parts such as diaphragms, valves and o-rings) to FIVE YEARS. To qualify for this extended warranty, the pump must be drained and flushed with fresh water after each day's use. HARDI®'s liability is limited to replacement of defective parts, FOB our plant in Davenport, IA at no cost to the purchaser during the first twelve months after date of purchase; at 20% of the then current retail price during the second year; at 40% during the third year; at 60% during the fourth year; and at 80% during the fifth year. This five year extended warranty is subject, in each instance, to the pump being inspected and approved for replacement or repair by HARDI® personnel before HARDI® will accept any liability hereunder.
10. HARDI® reserves the right to incorporate any change in design in its products without obligation to make such changes on units previously manufactured.
11. The judgement of the HARDI® Service Department in all cases of claims under this warranty shall be final and conclusive and the purchaser agrees to accept its decisions on all questions as to defect and the repair or exchange of any part or parts.
12. No employee or representative is authorized to change this warranty in any way or grant any other warranty unless such change is made in writing and signed by the CEO in the Davenport office. Approval of warranty is the responsibility of the HARDI® Service Department.
13. Any warranty work performed which will exceed \$1000.00 MUST be approved IN ADVANCE by the Service Department. Warranty claims filed without prior approval will be returned.
14. ANY pump replacement MUST be approved by the HARDI® Service Department.
15. Claims under this policy MUST be filed with the HARDI® Service Department within thirty (30) days of when the work is performed or warranty shall be void unless prior arrangements are made.
16. Parts which are requested for return by the HARDI® Service Department must be returned prepaid within thirty (30) days for warranty settlement.
17. Warranty claims must be COMPLETELY filled out including part numbers and quantities or claims will be returned to the submitting dealer.

## DISCLAIMER OF FURTHER WARRANTY

THERE ARE NO WARRANTIES, EXPRESSED OR IMPLIED, EXCEPT AS SET FORTH ABOVE.  
THERE ARE NO WARRANTIES WHICH EXTEND BEYOND THE DESCRIPTION OF THE PRODUCT CONTAINED HEREIN. IN NO EVENT SHALL THE COMPANY BE LIABLE FOR INDIRECT, SPECIAL OR CONSEQUENTIAL DAMAGES (SUCH AS LOSS OF ANTICIPATED PROFITS) IN CONNECTION WITH THE RETAIL PURCHASER'S USE OF THE PRODUCT.





**For Product, Service or Warranty Information:**

- Please contact your local HARDI® dealer.

**To contact HARDI® directly:**

- Please use the HARDI® Customer Service number: 1-866-770-7063

- Or send your email to: [CUSTSERV@hardi-us.com](mailto:CUSTSERV@hardi-us.com)

Visit us online at: [www.hardi-us.com](http://www.hardi-us.com)

**HARDI® NORTH AMERICA INC.**

1500 West 76th St.

Davenport, Iowa 52806

Phone: (563) 386-1730

Fax: (563) 386-1280

