

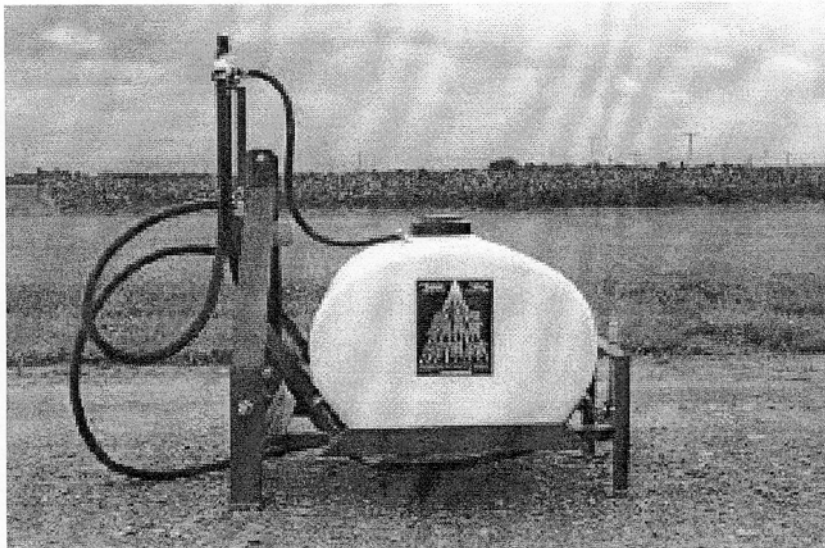

# **AG SPRAY EQUIPMENT, INC.**

## **OWNERS MANUAL**



**RM 55 HORIZONTAL**

**HYPRO 6 ROLLER PUMP**

**BOOMJET, BOOMEXTENDER, KLC, HAMILTON**

**&**

**AG 4 ROW DELUXE BOOM**

# RM 55 HORIZONTAL

## AG SPRAY EQUIPMENT

## OWNER'S MANUAL

---

Congratulations on purchasing your new three point hitch field sprayer. This manual is designed to aid you in operating your new sprayer. Also enclosed is a parts breakdown on your roller pump, pressure regulator, 43L-AL spray gun, and calibration on the KLC-18, Boomjet, Hamilton, Boomextender boomless nozzles & 4 row deluxe boom.

### WARRANTY

All Field Sprayers are under warranty by **Ag Spray Equipment, Inc.** for a one year period from the date of purchase. This warranty only applies to defects in workmanship or manufactures defects in their components. This warranty does not cover any misuse, abuse, or parts that may freeze & break. Owners are responsible for these issues. Parts proven defective before the one year period will be replaced at no charge.

**Ag Spray Equipment, Inc.** must be notified immediately of any defects or parts broken due to shipping on the sprayer before the one year period occurs. Waiting until after the one year period whether the sprayer has been ran once, twice, or none at all; warranty is void. No product will be accepted for return without authorization. All returned goods must be packaged securely and shipped with transportation charges prepaid.

For further information regarding parts or warranty, contact:

**Ag Spray Equipment, Inc.**  
**1100 New Industry Lane**  
**Hopkinsville, KY 42240**  
**Phone: 1-800-637-7172**

### Operation & Instructions of New Sprayer

First, back your tractor up to the sprayer, let lift arms all the way down & insert the lift pins into the lift arms of the tractor & secure with lock pins. Secondly, hook up the top link on the tractor to the very top hole of the frame. Next, connect the pump to the PTO shaft on your tractor by pulling the orange coupler back while sliding it onto the PTO shaft until the balls lock into the grooves on the shaft. After pump is secure take the chain & wrap it around the drawbar of the tractor using the snap link to snap the chain together to keep pump from twisting hoses when PTO is engaged.

Next, fill the tank at least  $\frac{1}{4}$  to  $\frac{1}{2}$  full of plain water with no chemicals. Screw the pressure regulator part of the way out (gray knob) & make sure agitation valve is  $\frac{3}{4}$  of the way open if supplied (55 gallon sprayers do not have agitation valve). This ensures that you do not peg the gauge & break it. Also, make sure valve under tank is on (handle should be turned going w/ the line).

You are now ready to try out your sprayer. By engaging PTO lever & pulling throttle to the 540RPM mark on the RPM gauge turn boom valve on & adjust the desired pressure that you will need to operate at. Adjust pressure with the pressure regulator (gray knob) & not the agitation valve because you need to keep agitation constant.

# CALIBRATING YOUR SPRAYER

## HAMILTON NOZZLE 6541-01

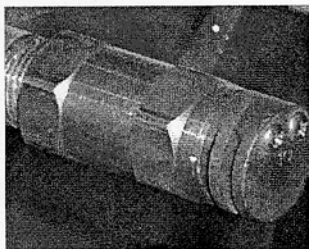

### CALIBRATING YOUR SPRAYER

To determine pressure & GPA with a boomless nozzle use this calibration formula.

$$\text{GPA} = \frac{495 \times \text{GPM}}{\text{MPH} \times \text{Swath in feet}}$$

**EXAMPLE:**  $\frac{495(\text{constant}) \times 4.2\text{gpm}}{4\text{mph} \times 50'\text{swath}} = 2079$

$$\frac{2079}{200} = 10.395 \text{ GPA}$$

*Refer to Chart*

### OPERATING DATA OF 180\* NOZZLES

SPRAYERS ARE SUPPLIED w/ #20

Orifice Number	PSI	GPM 180*	Swath 180*	GALLON PER ACRE				
				3 MPH	4 MPH	5 MPH	8 MPH	10 MPH
#5	30	1.7	44'	6.4	4.8	3.8	2.4	1.9
	40	2.0	46'	7.2	5.4	4.3	2.7	2.2
	50	2.2	48'	7.6	5.7	4.5	2.9	2.3
	60	2.4	50'	7.9	5.9	4.8	3.0	2.4
#10	30	3.7	50'	12.2	9.2	7.3	4.6	3.7
	40	4.2	50'	13.9	10.4	8.3	5.2	4.2
	50	4.6	52'	14.6	10.9	8.8	5.5	4.4
	60	5.0	52'	15.8	11.9	9.5	5.9	4.8
#20	30	5.1	54'	15.6	11.6	9.3	5.8	4.7
	40	5.9	54'	18.0	13.5	10.8	6.8	5.4
	50	6.7	56'	19.7	14.8	11.8	7.4	5.9
	60	7.1	58'	20.2	15.1	12.1	7.6	6.1

**GPM = Gallons Per Minute**  
**GPA = Gallons Per Acre**  
**MPH = Miles Per Hour**  
**PSI = Pressure Per Square Inch**

# SPRAYING SYSTEMS 5880 BOOMJET NOZZLE

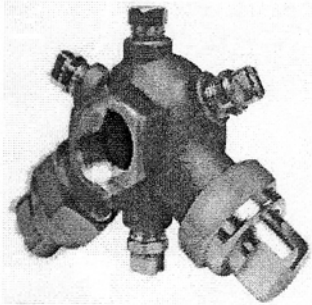

W = Maximum effective coverage with nozzle mounted at 36" height.

**\*NOTE:** BOOMJET SPRAYERS ARE STANDARD w/ #10 NOZZLE & a HYPRO 6 ROLLER PUMP.

Model	Nozzle	Filter	Strainer	PSI	Capacity of Nozzle in GPM	"W" (ft)	GPA				
							4 mph	5 mph	7.5 mph	10 mph	15 mph
5880-3/4-2TOC10	OC10	H1/4U-0508HE	H1/4VVL-11004 with 50 mesh strainer	20	2.83	39.5	8.9	7.1	4.7	3.5	2.4
				30	3.46	40	10.7	8.6	5.7	4.3	2.9
				40	4.00	40.5	12.2	9.8	6.5	4.9	3.3
5880-3/4-2TOC20	OC20	H1/4U-0520HE	H1/4VVL-9506 with 50 mesh strainer	20	6.08	47	16.0	12.8	8.5	6.4	4.3
				30	7.45	50	18.4	14.8	9.8	7.4	4.9
				40	8.60	52	20	15.4	10.9	8.2	5.5

## HYPRO BOOM X TENDER TIPS

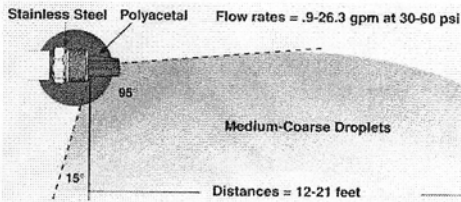

**\*NOTE:** YELLOW TIP-XT024 IS USED.

Broadcast & Turf Applications		Application Rate (GPA) Miles Per Hour															Gal/1000ft Squared	Swath Width (feet) 40 PSI	
Thread	XT Model	PSI	GPM	4	5	6	7	8	10	12	14	16	18	20	2	3	4	5	
1/4" MNPT	XT010	30	0.9	8.9	7.1	6.0	5.1	4.5	3.6	3.0	2.6	2.2	2.0	1.8	0.41	0.27	0.20	0.16	12
		40	1.0	10.3	8.3	6.9	5.9	5.2	4.1	3.4	2.9	2.6	2.3	2.1	0.47	0.31	0.24	0.19	
		50	1.1	11.5	9.2	7.7	6.6	5.8	4.6	3.8	3.3	2.9	2.6	2.3	0.53	0.35	0.26	0.21	
		60	1.2	12.6	10.1	8.4	7.2	6.3	5.1	4.2	3.6	3.2	2.8	2.5	0.58	0.39	0.29	0.23	
1/4" MNPT	XT020	30	1.7	12.6	10.1	8.4	7.2	6.3	5.0	4.2	3.6	3.2	2.8	2.5	0.58	0.38	0.29	0.23	17
		40	2.0	14.6	11.6	9.7	8.3	7.3	5.8	4.9	4.2	3.6	3.2	2.9	0.67	0.44	0.33	0.27	
		50	2.2	16.3	13.0	10.9	9.3	8.1	6.5	5.4	4.7	4.1	3.6	3.3	0.75	0.50	0.37	0.30	
		60	2.4	17.8	14.3	11.9	10.2	8.9	7.1	5.9	5.1	4.5	4.0	3.6	0.82	0.54	0.41	0.33	
1/4" MNPT	XT024	30	2.1	14.3	11.4	9.5	8.2	7.1	5.7	4.8	4.1	3.6	3.2	2.9	0.65	0.44	0.33	0.26	18
		40	2.4	16.5	13.2	11.0	9.4	8.3	6.6	5.5	4.7	4.1	3.7	3.3	0.76	0.50	0.38	0.30	
		50	2.7	18	14.8	12.3	10.5	9.2	7.4	6.1	5.3	4.6	4.1	3.7	0.84	0.56	0.42	0.34	
		60	2.9	20	16.2	13.5	11.5	10.1	8.1	6.7	5.8	5.1	4.5	4.0	1.0	0.65	0.49	0.39	
3/8" MNPT	XT043	30	3.7	23	18.4	15.4	13.2	11.5	9.2	7.7	6.6	5.8	5.1	4.6	1.1	0.70	0.53	0.42	20
		40	4.3	27	21.3	17.7	15.2	13.3	10.6	8.9	7.6	6.7	5.9	5.3	1.2	0.81	0.61	0.49	
		50	4.8	30	23.8	19.8	17.0	14.9	11.9	9.9	8.5	7.4	6.6	5.9	1.4	0.91	0.68	0.54	
		60	5.3	33	26.1	21.7	18.6	16.3	13.0	10.9	9.3	8.1	7.2	6.5	1.5	1.0	0.75	0.60	
1/2" MNPT		30	6.9	41	33	27	23	20	16.3	13.6	11.7	10.2	9.1	8.2	1.9	1.2	0.9	0.75	21
		40	8.0	47	38	31	27	24	19	15.7	13.5	11.8	10.5	9.4	2.2	1.4	1.1	0.86	
		50	8.9	53	42	35	30	26	21	17.6	15.1	13.2	11.7	10.5	2.4	1.6	1.2	1.0	
		60	9.8	58	46	38	33	29	23	19	16.5	14.4	12.8	11.5	2.6	1.8	1.3	1.1	
3/4" MNPT	XT167	30	14.5	99	80	66	57	50	40	33	28	25	22.1	19.9	4.6	3.0	2.3	1.8	18
		40	16.7	115	92	77	66	57	46	38	33	29	25.5	23.0	5.3	3.5	2.6	2.1	
		50	18.7	128	103	86	73	64	51	43	37	32	28.5	25.7	5.9	3.9	2.9	2.4	
		60	20.5	141	112	94	80	70	56	47	40	35	31.2	28.1	6.4	4.3	3.2	2.6	
3/4" MNPT	XT015	30	18.6	115	92	77	66	58	46	38	33	28.8	25.6	23.0	5.3	3.5	2.6	2.1	20
		40	21.5	133	106	89	76	67	53	44	38	33	30	26.6	6.1	4.1	3.0	2.4	
		50	24.0	149	119	99	85	74	59	50	42	37	33	30	6.8	4.5	3.4	2.7	
		60	26.3	163	130	109	93	81	65	54	47	41	36	33	7.5	5.0	3.7	3.0	

Note: All application rates are based on swath widths listed.

# KLC DIAGRAM & CALIBRATION



1/4" KLC-18 NOZZLE

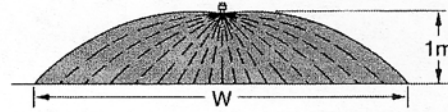

KLC DIAGRAM OF THE PATTERN

## CHART FOR KLC NOZZLE:

Determine speed you will be applying & adjust your pressure according to the gallons per acre (GPA) recommended.

	Pipe Conn.	PSI	Total Capacity GPM	"W" in feet	GPA				Gallons Per 1000 Sq. Ft.			
					3 mph	4 mph	5 mph	8 mph	3 mph	4 mph	5 mph	8 mph
¼-KLC-5	¼"	20	0.71	17	6.9	5.2	4.1	2.6	.16	.12	.09	.06
		30	0.87	18	8.0	6.0	4.8	3.0	.18	.14	.11	.07
		40	1.00	21	7.9	5.9	4.7	2.9	.18	.13	.11	.07
¼-KLC-9	¼"	20	1.27	18	11.6	8.7	7.0	4.4	.27	.20	.16	.10
		30	1.56	19	13.5	10.2	8.1	5.1	.31	.23	.19	.12
		40	1.80	21	14.1	10.6	8.5	5.3	.32	.24	.19	.12
¼-KLC-18	¼"	20	2.55	20	21	15.8	12.6	7.9	.48	.36	.29	.18
		30	3.12	21	25	18.4	14.7	9.2	.56	.42	.34	.21
		40	3.60	22	27	20	16.2	10.1	.62	.46	.37	.23
¼-KLC-36	¼"	20	5.09	22	38	29	23	14.3	.87	.66	.52	.33
		30	6.24	24	43	32	26	16.1	.98	.74	.59	.37
		40	7.20	26	46	34	27	17.1	1.0	.78	.63	.39
¼-KLC-50	¾"	20	7.07	23	51	38	30	19.0	1.2	.87	.70	.44
		30	8.66	26	55	41	33	21	1.3	.94	.75	.47
		40	10.0	28	59	44	35	22	1.3	1.0	.81	.51
¼-KLC-72	¾"	20	10.2	25	67	50	40	25	1.5	1.2	.92	.58
		30	12.5	29	71	53	43	27	1.6	1.2	.98	.61
		40	14.4	31	77	57	46	29	1.8	1.3	1.1	.66
¼-KLC-108	¾"	20	15.3	28	90	68	54	34	2.1	1.5	1.2	.77
		30	18.7	33	94	70	56	35	2.1	1.6	1.3	.80
		40	21.6	36	99	74	59	37	2.3	1.7	1.4	.85

Note: Always double check your application rates.

# TEEJET SPRAY TIP CALIBRATION

## BA4DSQ

All standard booms come w/ 8003VP poly tips.

The 4 Row booms have 9 nozzles.

### Formula:

$$\frac{\text{GPA} \times \text{MPH} \times \text{Nozzle Spacing}}{5940}$$

### Example:

$$\frac{20\text{gpa} \times 4\text{mph} \times 20''}{5940} = \frac{1600}{5940} = .27\text{gpm}$$

Take the GPM that you figured & look down the GPM chart to figure what pressure you need to run at that desired speed.

**\*NOTE:** If spraying liquid nitrogen you will need to multiply the conversion factor w/ the gpa, mph, & nozzle spacing.

Conversion Factor: 28% Nitrogen - 10.65 lbs. per gal. - 1.13  
32% Nitrogen - 11.00 lbs. per gal. - 1.15

Ex.  $\frac{20\text{gpa} \times 4\text{mph} \times 20'' \times 1.13}{5940} = \frac{1808}{5940} = .31\text{gpm}$

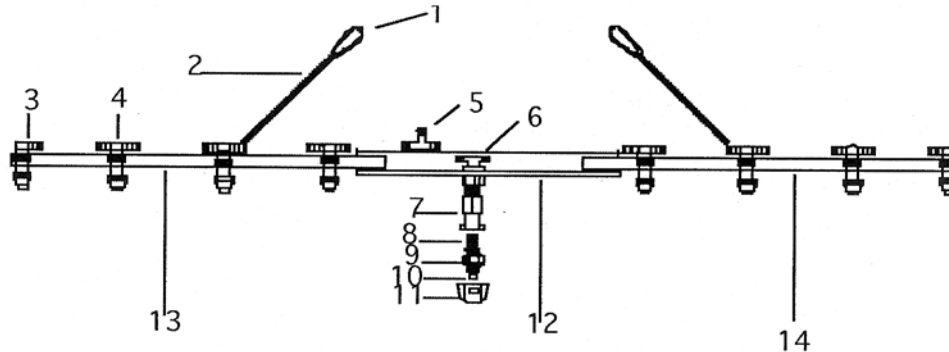

1. Snap Link \_"
2. Breakaway Spring
3. 18635406 - 3/8" QJ Body - Elbow
4. 18636406 - 3/8" QJ Body - Tee
5. T38
6. NTT38
7. QJT-NYB
8. 50 Mesch Poly Strainer
9. EPDM Gasket
10. 8003VP Tip
11. Quick Jet Slotted Cap
12. Center Section
13. Left Arm Boom Pipe - 6' Long
14. Right Arm Boom Pipe - 6' Long

PSI	PSI	PSI	GPM	GPA 20"											
				4 MPH	5 MPH	6 MPH	7 MPH	8 MPH	9 MPH	10 MPH	12 MPH	14 MPH	16 MPH	18 MPH	20 MPH
AI(30-115)	D25143-UB-8502 (DG, TJ60, TP, XR) 8002 (AI, DG, TJ60, TP, TT, XR) 11002 1/4TTJ02	15	0.12	8.9	7.1	5.9	5.1	4.5	4.0	3.6	3.0	2.5	2.2	2.0	1.8
DG(30-60)		20	0.14	10.4	8.3	6.9	5.9	5.2	4.6	4.2	3.5	3.0	2.6	2.3	2.1
TJ60(30-60)		30	0.17	12.6	10.1	8.4	7.2	6.3	5.6	5.0	4.2	3.6	3.2	2.8	2.5
TP(30-60)		40	0.20	14.9	11.9	9.9	8.5	7.4	6.6	5.9	5.0	4.2	3.7	3.3	3.0
TT(15-90)		50	0.22	16.3	13.1	10.9	9.3	8.2	7.3	6.5	5.4	4.7	4.1	3.6	3.3
TTJ(25-75)		60	0.24	17.8	14.3	11.9	10.2	8.9	7.9	7.1	5.9	5.1	4.5	4.0	3.6
AI(30-115)	D25143-UB-8503 (DG, TJ60, TP, XR) 8003 (AI, DG, TJ60, TP, TT, XR) 11003 AIUB8503	15	0.18	13.4	10.7	8.9	7.6	6.7	5.9	5.3	4.5	3.8	3.3	3.0	2.7
AiUB(30-115)		20	0.21	15.6	12.5	10.4	8.9	7.8	6.9	6.2	5.2	4.5	3.9	3.5	3.1
DG(30-60)		30	0.26	19.3	15.4	12.9	11.0	9.7	8.6	7.7	6.4	5.5	4.8	4.3	3.9
TJ60(30-60)		40	0.30	22	17.8	14.9	12.7	11.1	9.9	8.9	7.4	6.4	5.6	5.0	4.5
TP(30-60)		50	0.34	25	20	16.6	14.4	12.6	11.2	10.1	8.4	7.2	6.3	5.6	5.0
TT(15-90)		60	0.37	27	22	18.3	15.7	13.7	12.2	11.0	9.2	7.8	6.9	6.1	5.5
AI(30-115)	D25143-UB-8504 (DG, TJ60, TP, XR) 8004 (AI, DG, TJ60, TP, TT, XR) 11004 AIUB8504	15	0.24	17.8	14.3	11.9	10.2	8.9	7.9	7.1	5.9	5.1	4.5	4.0	3.6
AiUB(30-115)		20	0.28	21	16.6	13.9	11.9	10.4	9.2	8.3	6.9	5.9	5.2	4.6	4.2
DG(30-60)		30	0.35	26	21	17.3	14.9	13.0	11.6	10.4	8.7	7.4	6.5	5.8	5.2
TF(10-40)		40	0.40	30	24	19.8	17.0	14.9	13.2	11.9	9.9	8.5	7.4	6.6	5.9
TJ60(30-60)		50	0.45	33	27	22	19.1	16.7	14.9	13.4	11.1	9.5	8.4	7.4	6.7
TP(30-60)		60	0.49	36	29	24	21	18.2	16.2	14.6	12.1	10.4	9.1	8.1	7.3

# HYPRO 6500C, 6500N, & 6500XL

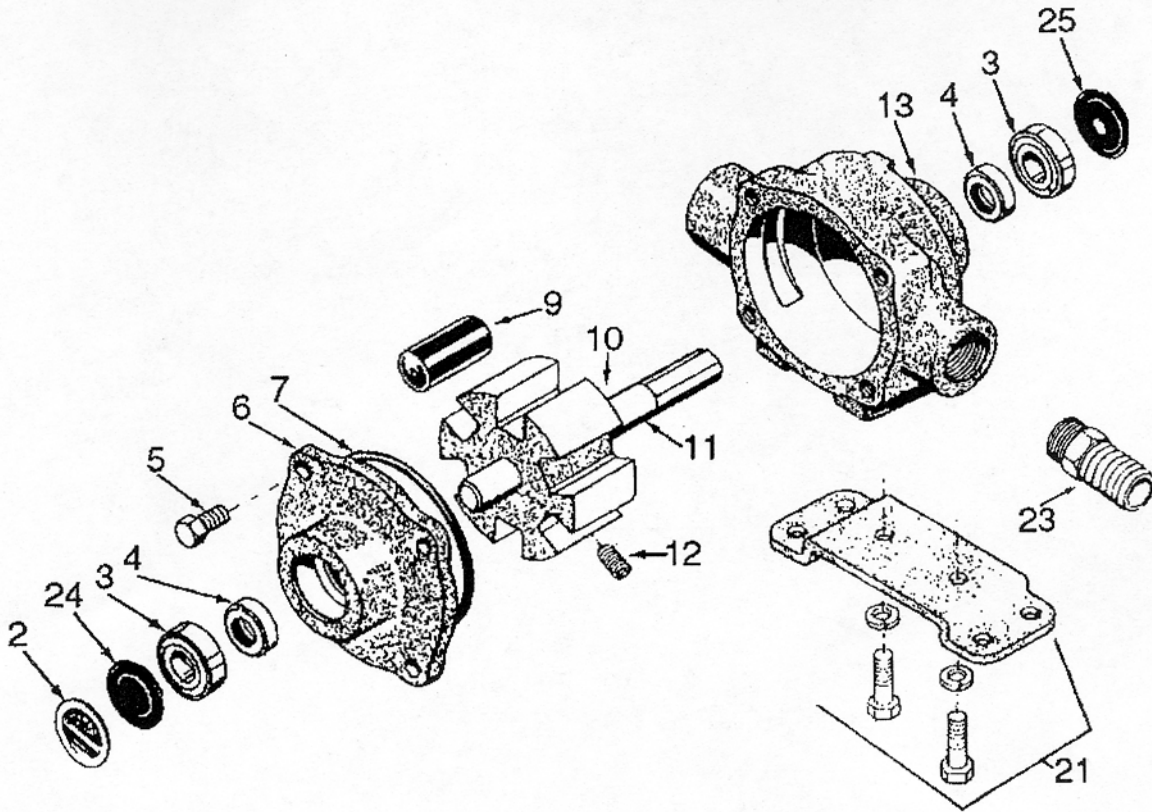

Ref. No.	Qty. Req'd.	Part Number	Description
2	1	6031-0258	Name Plate (Specify Pump Model #)
3	2	2000-0010	Ball Bearing
4	2	2107-0002	Viton Seal (Standard)
4	2	2102-0001	Buna-N Seal (Optional)
4	2	2103-0001	Leather Seal (Optional)
5	4	2210-0004	Bolt for Endplate
6	1	0200-6600C	Endplate (Cast Iron) with Standard Seal
6	1	0200-6600N	Endplate (NI-Resist) with Standard Seal
6	1	0200-6600X	Endplate (SilverCast) with Standard Seal
7	1	1720-0008	O-ring for Endplate
9	6	1005-0004	Super Roller (Standard)
9	6	1002-0004	Polypropylene Roller (Optional)
9	6	1055-0004	Teflon Roller (Optional)
9	6	1052-0004	Buna-N Roller (Optional)
10	1	0300-6600C	Rotor (Cast Iron) with shaft
10	1	0300-6600N	Rotor (Ni-Resist) with shaft
10	1	0300-6600X	Rotor (SilverCast) with shaft
11	1	0500-6600	Shaft Only
12	1	2230-0003	Set Screw
12	1	2230-0007	Set Screw (SilverCast Only)

**Repair Parts Kit No. 3430-0343 (Universal)** Consists of: (8) Ref. 8 Super Rollers, (2) Ref. 7 O-rings and (4) Ref. 4 Viton Seals of two different sizes.

**Repair Parts Kit No. 3430-0380** Consists of: (6) Ref. 8 Super Rollers, (1) Ref. 7 O-rings and (2) Ref. 4 Viton Seals.

**Repair Parts Kit No. 3430-0174** Consists of: (6) Ref. 8 Polypropylene Rollers and (1) Ref. 7 O-Ring Gasket.

Ref. No.	Qty. Req'd.	Part Number	Description
13	1	0100-6600C	Body (Cast Iron) with Seal
13	1	0100-6600N	Body (Ni-Resist) with Seal
13	1	0100-6600X	Body (SilverCast) with Seal
14	1	1320-0022	1-3/8" 6-spline 540 rpm PTO Adapter (Includes (2) 2230-0012 and (1) 2230-0003 Set Screws)
15	2	2230-0012	5/16" x 1/2" Set Screw
17	1	1320-0053	1-3/8" 21-spline 1000 rpm PTO Adapter (Includes (2) 2230-0012 and (1) 2230-0003 Set Screws)
18	1	2230-0003	5/16" x 3/8" Set Screw
21	1	3420-0023	Base Kit — Includes: (1) Base, (2) Bolts, and (2) Lockwashers
22	1	1321-0006	Quick Coupler Adapter for 1-3/8" 6-spline 540 rpm PTO <i>NOT SHOWN</i>
22	1	1321-0008	Quick Coupler Adapter for 1-3/8" 21-spline 1000 rpm PTO <i>NOT SHOWN</i>
23	1	2404-0052	1" Hose Barb
24	1	2300-0021	Bearing Cover
25	1	2300-0023	Shaft Bearing Cover

**Repair Parts Kit No. 3430-0175** Consists of: (6) Ref. 8 Polypropylene Rollers, (1) Ref. 7 O-Ring Gasket, and (2) Ref. 4 Viton Seals.

# PRESSURE HEADS

## PRESSURE HEAD FOR RM 55H-4D

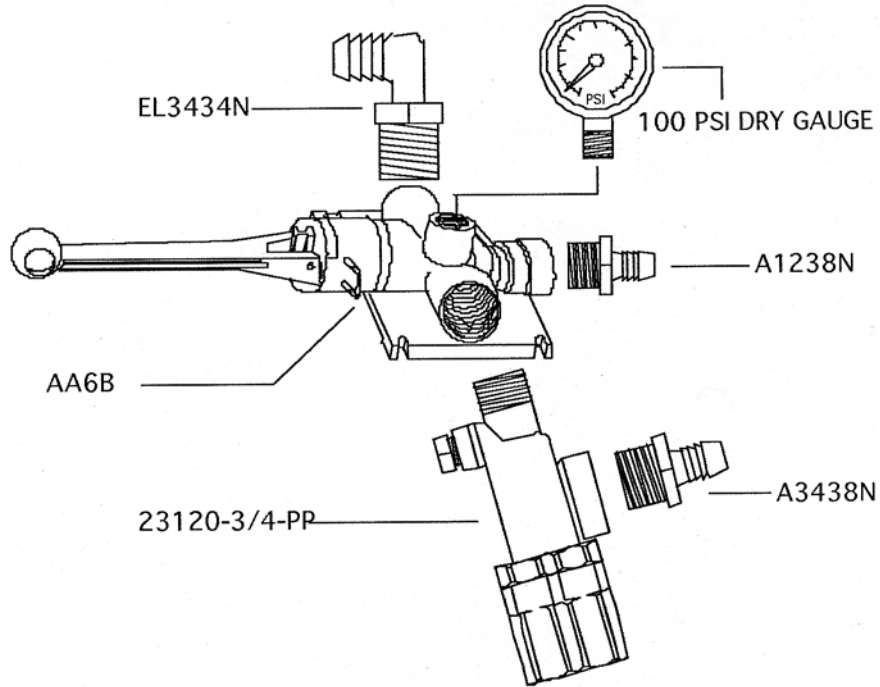

## PRESSURE HEAD FOR RM 55 H BXT

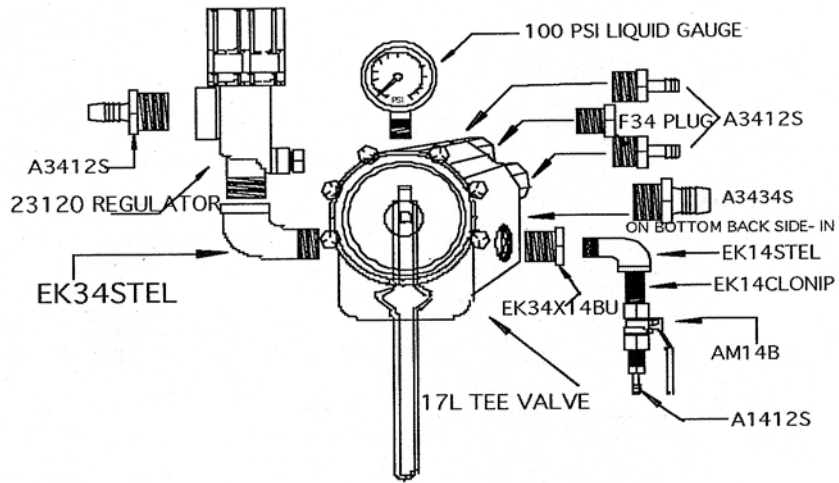

## PRESSURE HEAD FOR RM 55 H BOOMJET, HAMILTON & KLC

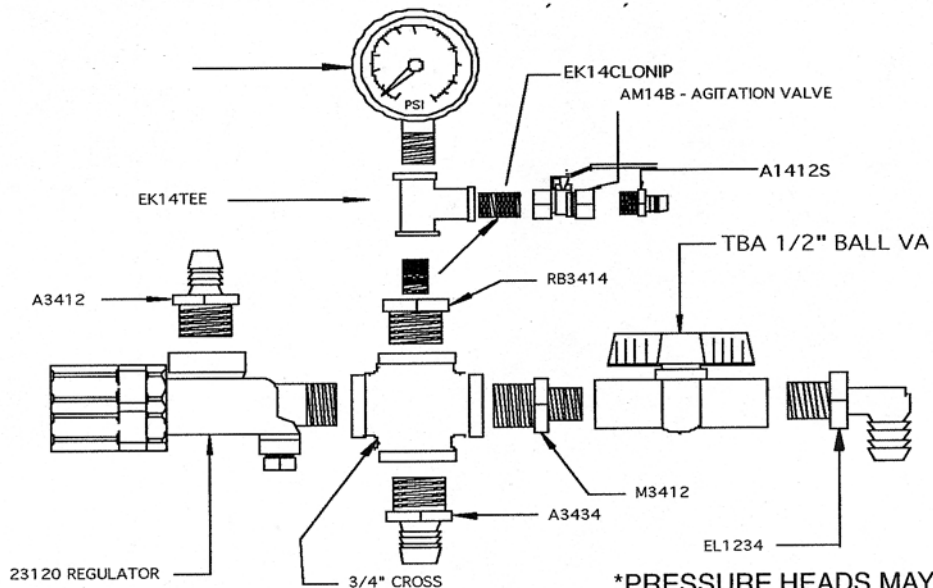

\*PRESSURE HEADS MAY VARY SLIGHTLY



# TANK PLUMBING

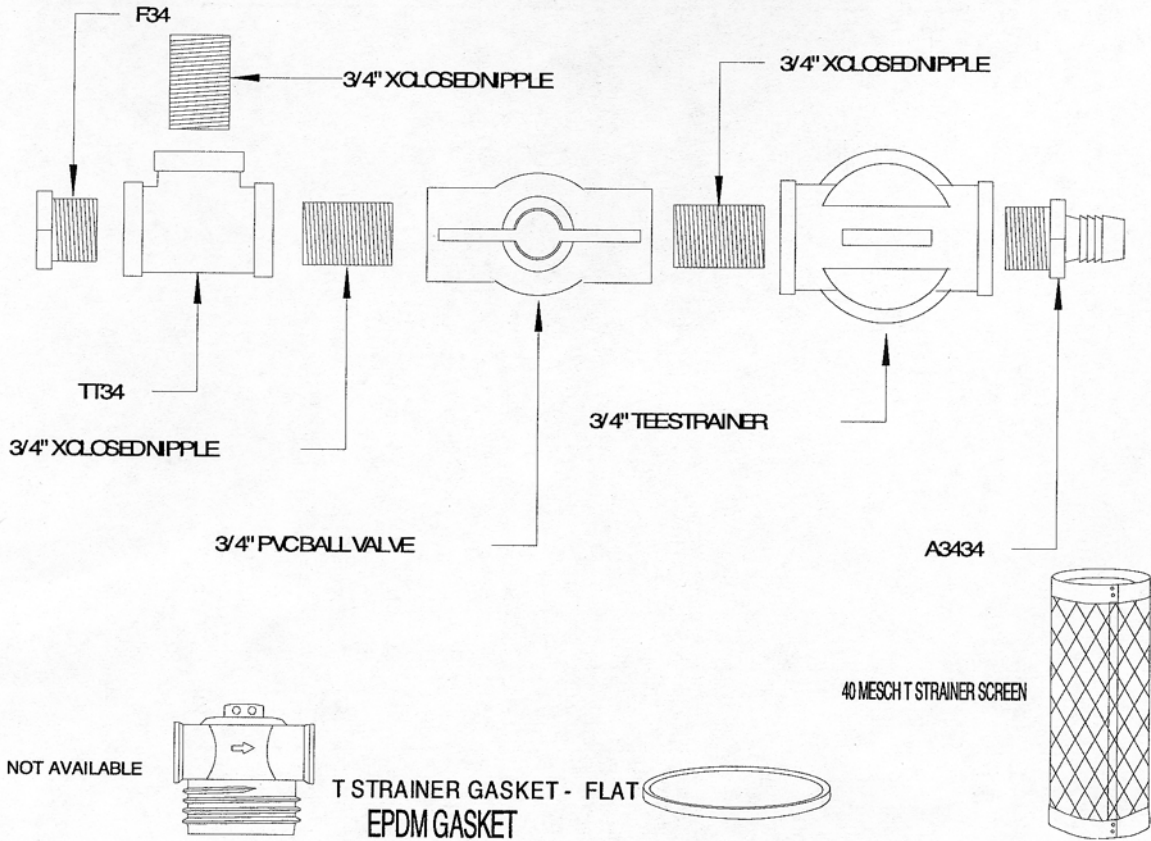

# SPRAYING SYSTEMS 23120 REGULATOR

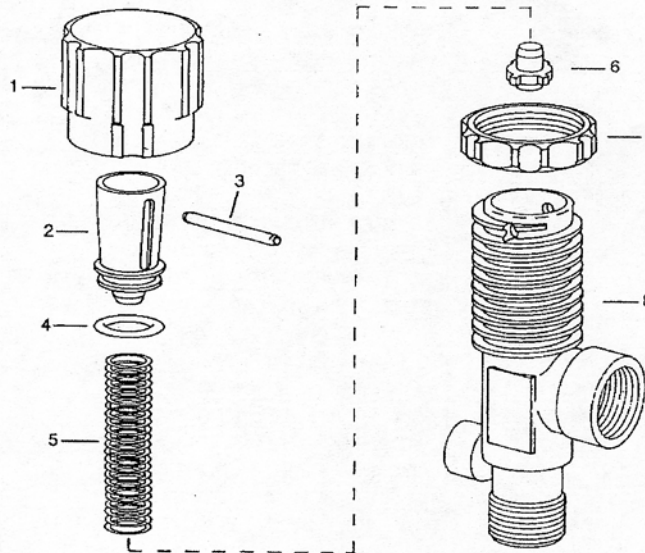

ITEM	PART NO.	DESCRIPTION
1	CP23122-NY	Adjusting Cap, Nylon (Gray)
2	CP23124-PPB	Spring Retainer, Polypropylene (Black)
3	CP23126-302SS	Retaining Pin, Type 302 Stainless Steel
4	CP7717-15-	O'Ring
5	CP23127-316SS	Spring, Type 316 Stainless Steel
6	CP23125-PPB	Guide Seat, Polypropylene (Black)
7	CP23123-PP	Lock Ring, Polypropylene (Gray)
8	CP23128-1-PPB	Body, Polypropylene (Black) For Model 23120A-1/2-PP
	CP23121-1-PPB	Body, Polypropylene (Black) For Model 23120A-3/4-PP
No. 23120A-1/2-PP Pressure Relief Valve		
No. 23120A-3/4-PP Pressure Relief Valve		
PK-AB23120 - Kit - Spare Parts Kit (includes all items marked with *)		

# SPRAYING SYSTEMS 43L-AL SPRAY GUN

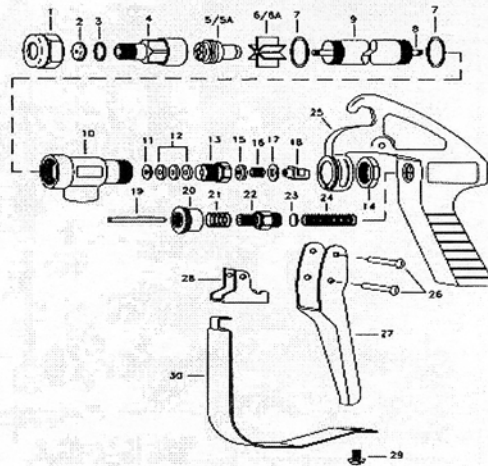

ITEM	PART #		DESCRIPTION
	BRASS	ALUMINUM	
1	CP1325	CP1325-AL	CAP, BRASS, or ALUMINUM
2	D-**	D-**	ORIFICE DISC, HARDENED STAINLESS STEEL
3	CP4743-NY	CP4743-NY	GASKET, NYLON
4	CP10566	CP10566-AL	NOZZLE HOUSING, BRASS or ALUMINUM
5A	10565	10565-AL	SEAT PLUG ASSEMBLY - BRASS or ALUMINUM
6	CP10571-2-NYB	CP10571-3-NYB	GUIDE VANE, NYLON
6A		CP10571-AL	GUIDE VANE, ALUMINUM
7	CP45195-NYB	CP45196-NYB	GASKET, NYLON (2 REQUIRED)
8	CP19238-416SS	CP19238- 416SS	STEM, TYPE 416 STAINLESS STEEL
9	CP6604	CP6604-AL	TUBING, BRASS or ALUMINUM
10	CP6942	CP6942-AL	INLET BODY, BRASS or ALUMINUM
11	CP6601-302SS	CP6601-302SS	PACKING WASHER, TYPE 302 STAINLESS STEEL
12	CP6602-LEA	CP6602-LEA	PACKING LEATHER ( 3 REQUIRED)
	CP6602-TEF	CP6602-TEF	PACKING TEFLON (3 REQUIRED)
13	CP19237	CP19237-AL	PACKING SCREW, BRASS or ALUMINUM
14	CP6599	CP6599-IZP	LOCKNUT, BRASS, or STEEL ZINC PLATED
15	CP9641-INP	CP9641-INP	STEM NUT, STEEL NICKEL PLATED
16	CP6595-SS	CP6595-SS	TRIGGER STOP SPRING, SS
17	CP7991-SS	CP7991-SS	WASHER, SS
18	CP6597-INP	CP6597-INP	TRIGGER GUIDE, STEEL NICKEL PLATED
19	CP6591-SS	CP6591-SS	SPRING STUD, STAINLESS STEEL
20	CP6589-IZP	CP6589-IZP	STOP ADJUSTMENT NUT, STEEL ZINC PLATED
21	CP6594-SS	CP6594-SS	SPRING FOR STOP ADJUSTMENT NUT, SS
22	CP6588-IZP	CP6588-IZP	SPRING SCREW, STEEL ZINC PLATED
23	CP6592-302SS	CP6592-302SS	SPRING GUIDE WASHER, TYPE 302 SS
24	CP6593-1-SS	CP6593-1-SS	MAIN SPRING, SS for MODEL 43L
	CP6593-2-SS	CP6593-2-SS	MAIN SPRING, SS for MODEL 43H
25	CP14477-1-AL	CP14477-1-AL	HANDLE BODY, ALUMINUM
26	CP7623-IZP	CP7623-IZP	RIVET, STEEL NICKEL PLATED
27	CP6509-INP	CP6509-INP	TRIGGER, STEEL NICKEL PLATED
28	CP6510-INP	CP6510-INP	TRIGGER STOP, STEEL NICKEL PLATED
29	CP11757-SS	CP11757-SS	SCREW, STAINLESS STEEL
30	CP13798-INP	CP13798-INP	TRIGGER GUARD, STEEL NICKEL PLATED
			GUNJET No. AA43L - BRASS, FOR PRESSURE UP TO 200 psi
			GUNJET No. AA43L-AL - ALUMINUM, FOR PRESSURE UP TO 200 psi
			GUNJET No. AA43H - BRASS, FOR PRESSURES FROM 200 to 800psi
			GUNJET No. AA43H-AL - ALUMINUM FOR PRESSURES FROM 200 to 800psi
			PK-AB43-KIT SPARE PARTS KIT (includes all items marked)
			PK-AB43-AL-KIT SPARE PARTS KIT (includes all items marked)

# **TROUBLE SHOOTING**

---

## **PROBLEM**

---

### **1. NO PRESSURE**

- A. PUMP NOT PROPERLY PRIMED**
  - B. STRAINER STOPPED UP**
  - C. PUMP SUCKING AIR or PUMP HAS AIR LOCK. CHECK HOSES FOR CRACKS or HOLES. MAKE SURE FITTINGS ARE TIGHT. CENTRIFUGAL PUMP MAY HAVE AIR LOCK. UNSCREW 1/8" PLUG FROM TOP UNTIL WATER SHOOTS OUT OF IT**
  - D. SUCTION LINE SUCKING TOGETHER – NEED STIFFER HOSE**
  - E. WORN or LEAKING SEALS**
- 

### **2. PUMP RUNS, BUT LOW PRESSURE**

- A. SUCTION LINE & FITTINGS STOPPED UP or HOSE KINKED**
  - B. WORN ROLLERS or IMPELLAR**
  - C. STOPPED UP STRAINER**
- 

### **3. PUMP PRESSURE GOOD BUT LOW OUTPUT THROUGH NOZZLES**

- A. NOZZLE SIZE MAYBE TOO SMALL. CHECK CALIBRATION & GALLONS PER ACRE**
  - B. LET LINE TOO SMALL or BLOCKED OFF**
  - C. BY-PASS OPEN TOO MUCH. CLOSE A LITTLE MORE**
- 

### **4. EXCESSIVE VIBRATION or NOISE**

- A. POSSIBLE LOOSE COULER – DAMAGED SHAFT**
  - B. EXCESSIVE PTO or ENGINE SPEED**
  - C. IMPELLAR or INTERNAL PROBLEM**
-

