

Contents

EC Declaration of Conformity	2
Operator safety	3
Description	4
Operation diagram	5
Connecting the sprayer	5
Transmission shaft	6
Rear lights (if fitted)	7
Roadworthiness	7
Operating instructions	8
Filling the main tank	8
Operation of the boom	8
Boom height	9
Pulsation damper	9
Adjustment of the operating unit	10
Drain valve operation	11
Maintenance	11
Filters	11
Lubrication	12
Re-adjustment of the boom	15
Changing of valves and diaphragms	16
Nozzle tubes and fittings	18
Off-season storage	18
Operational problems	20
Technical specifications	22
Pictorial symbols	24
Assembly	25
Preassembly information	25
Spare part drawings	34

NL

Instruction book

674202-GB-95/10



EC Declaration of Conformity

Manufacturer,

HARDI INTERNATIONAL A/S
Helgeshøj Allé 38
DK 2630 Taastrup
DENMARK

Importer,

declare that the following product;

.....
.....

Adhere extra shipping package labels to inside cover.

A. was manufactured in conformity with the provisions in the COUNCIL DIRECTIVE of 14 June 1989 on mutual approximation of the laws of the Member States on the safety of machines (89/392/EEC as amended by directives 91/368/EEC and 93/368/EEC) with special reference to Annex 1 of the Directive on essential safety and health requirements in relation to the construction and manufacture of machines.

B. was manufactured in conformity with the standards current at that time that implements a harmonised standard in accordance with Article 5 (2) and other relevant standards.

Taastrup 1.2.99

















Erik Holst
Managing Director
HARDI INTERNATIONAL A/S

Operator safety



Watch for this symbol . It means WARNING, CAUTION, NOTE. Your safety is involved so be alert!

Note the following recommended precautions and safe operating practices.

-  Read and understand this instruction book before using the equipment. It is equally important that other operators of this equipment read and understand this book.
-  Local law may demand that the operator be certified to use spray equipment. Adhere to the law.
-  Pressure test with clean water prior to filling with chemicals.
-  Wear protective clothing.
-  Rinse and wash equipment after use and before servicing.
-  Depressurize equipment after use and before servicing.
-  Never service or repair the equipment whilst it is operating.
-  Disconnect electrical power before servicing.
-  Always replace all safety devices or shields immediately after servicing.
-  If an arc welder is used on the equipment or anything connected to the equipment, disconnect power leads before welding. Remove all inflammable or explosive material from the area.
-  Do not eat, drink or smoke whilst spraying or working with contaminated equipment.
-  Wash and change clothes after spraying.
-  Wash tools if they have become contaminated.
-  In case of poisoning, seek doctor or ambulance. Remember to identify chemicals used.
-  Keep children away from the equipment.
-  Do not attempt to enter the tank.
-  If any portion of this instruction book remains unclear after reading it, contact your HARDI dealer for further explanation before using the equipment.



We congratulate you for choosing a HARDI plant protection product. The reliability and efficiency of this product depend on your care. The first step is to carefully **read and pay attention** to this instruction book. It contains essential information for the efficient use and long life of this quality product.

As the instruction book covers all NL models, please pay attention to the paragraphs dealing with precisely your model. This book is to be read in conjunction with the Spray Technique book.



Description

The Hardi **NL** models consist of a pump, frame with tank of 300, 400, 600 or 800 litre capacity, M-70 operating unit, **SB** booms (if fitted) of 6, 8, 10, or 12 metre and transmission shaft.

The design of the diaphragm pump is simple, with easily accessible diaphragms and valves that ensures liquid does not come in contact with the vital parts of the pump.

The tank, made of impact-proof and chemical resistant polyethylene, has a purposeful design with no sharp edges for easy cleaning and efficient agitation. A suction filter is located at the top of the tank. This facilitates filter inspection even if the tank is filled with spray liquid.

The M-70 operating unit consists of; on/off function, pressure regulation valve with pressure gauge and distribution valves for closing of spray boom sections.

The **SB** boom is bolted to the tank frame and is fitted with spring loaded breakaways at the pivots.

An identification plate fitted on the frame indicates model, year of production and serial number, and country of origin.

Operation diagram

1. Suction filter
2. Pump
3. On/off and pressure regulation valve
4. Distribution valves
5. Sprayer boom

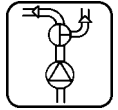
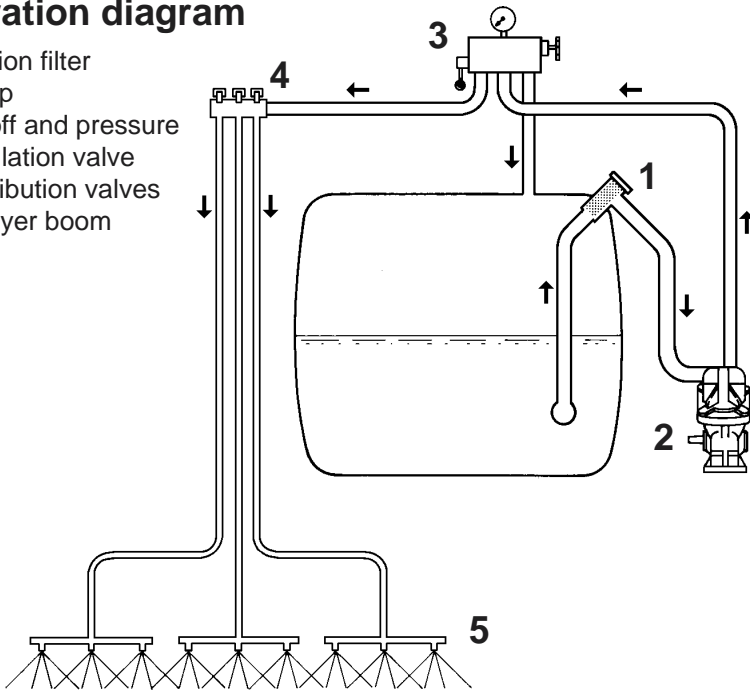

Connecting the sprayer

The sprayer is designed for three point suspension and is equipped with 22 mm pivots (category I). 28 mm (category II) pivots are fitted on the 800 litre models.

WARNING: Note the weight of the sprayer. See section on Technical specifications.

Generally it is recommended to:

1. Add ballast to front of tractor.
2. Increase tyre pressure (see tractor instruction book).
3. Travel at slower speeds when driving with a full tank.
(The tractor will have decreased braking efficiency.)
4. Be careful when filling/lifting the sprayer the first time.

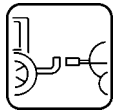
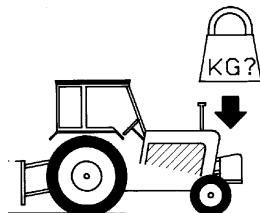

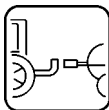

Transmission shaft

Operator safety

To avoid accidents and personal injuries, note the following recommended precautions and safe operation practices.



Always STOP ENGINE before attaching the transmission shaft to tractor P.T.O. - most tractor P.T.O. shafts can be rotated by hand to facilitate spline alignment, when engine is stopped.

When attaching the shaft, make sure that the snap lock is FULLY ENGAGED - push and pull shaft until it locks.



WARNING: ROTATING TRANSMISSION SHAFTS WITHOUT PROTECTION GUARDS ARE FATAL.

Always keep protection guards and chains intact and make sure that they cover all rotating parts, including cross journals at each end of the shaft. Do not use without protection guard.

Do not touch or stand on the transmission shaft when it is rotating - safety distance: 1.5 meter.

Prevent protection guards from rotating by attaching the chains, allowing sufficient slack for turns.

Make sure that protection guards around tractor P.T.O. and implement shaft are intact.

Always STOP ENGINE and remove the ignition key before carrying out maintenance or repairs to the transmission shaft or implement.

Installation of transmission shaft

Initial installation of the shaft is done as follows:

1. Attach sprayer to tractor and set sprayer in the position with **shortest** distance between the tractor and sprayer pump P.T.O. shafts.
2. Stop engine and remove ignition key.
3. If transmission shaft must be shortened, the shaft is pulled apart. Fit the two shaft parts at tractor and sprayer pump and measure how much it is necessary to shorten the shaft. Mark the protection guards.

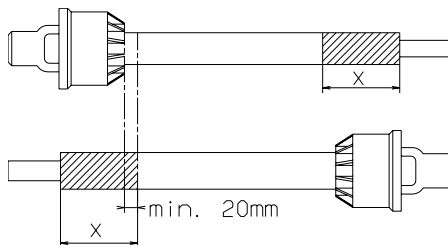

NOTE: The shaft must always have a minimum overlap of 150 mm.

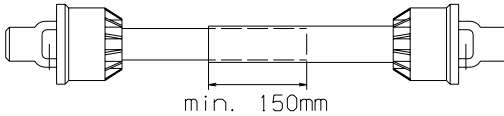

4. The two parts are shortened equally. Use a saw, and file the profiles afterwards to remove burrs.
5. Grease the profiles and assemble male and female parts again.

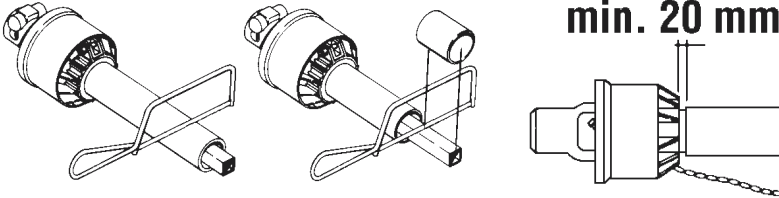

6. Fit the shaft to tractor and sprayer pump.
NOTE: Female part towards tractor.
Fit the chains to prevent the protection guards to rotate with the shaft.

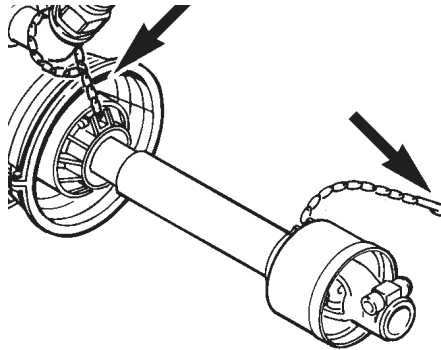

7. To ensure long life of the transmission shaft, try to avoid working angles larger than 15°.
8. Transmission shafts with cone must be fitted by tightening the Allen screw to a torque of 40 Nm.
Check again.

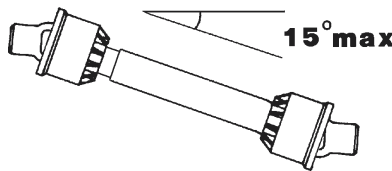

Rear lights (if fitted)

Connect plug for rear lights to tractors 7-poled socket and check that rear lights, stop lights and turning indicators function properly.

Roadworthiness

When driving on public roads and other areas where the highway code applies, or areas where there are special rules and regulations for marking and lights on implements, you should observe these and equip implements accordingly.

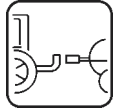



Operating instructions

Filling the main tank

Water is filled into the tank by removing the tank lid located right on top of the sprayer tank. It is recommended to use as clean water as possible for spraying purposes. Always fill water through the strainer basket to prevent foreign particles from entering the tank. An overhead tank can be used in order to obtain high filling capacity.



WARNING: Do not let the filling hose enter the tank. Keep it outside the tank, pointing towards the filling hole. If the hose is lead into the tank and the water pressure drops at the water supply plant, chemicals may be syphoned back and contaminate the water supply lines, plant and well.

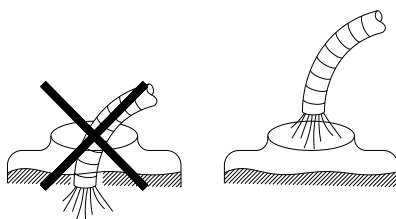

Operation of the boom

Remove boom transport lock pin. When unfolding (or folding) the initial force to release the spring loaded breakaways will be higher than the actual unfolding/folding.

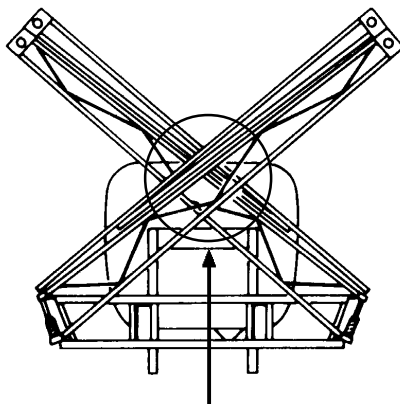

CAUTION: The breakaways must be correctly tensioned and lubricated. (see section on Boom breakaway)

Replace boom transport lock pin when driving with folded boom.

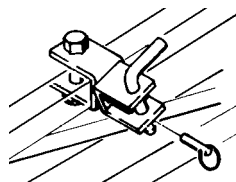

Boom height

Correct boom height is very important in order to achieve the most optimal spray pattern. (See Spray Technique book).



Small adjustments of the boom height can usually be made with the 3-point suspension from the tractor - raising or lowering the sprayer.

In crops where greater adjustments are needed the boom height can be changed manually by removing the 4 bolts holding the boom to the frame.

Note: This is best done by 2 persons or with a mechanical hoist.

Pulsation damper

The air pressure in the pulsation damper is preset at the factory to 2 bar. This covers spray working pressures between 3 and 15 bar. When using spray pressures outside this range, the air pressure should be adjusted as shown in the diagram. The diagram is also embossed on the damper.

	
bar	bar
15 - 3	0 - 1
3 - 15	1 - 3
15 - 25	3 - 4

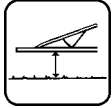



Adjustment of the operating unit

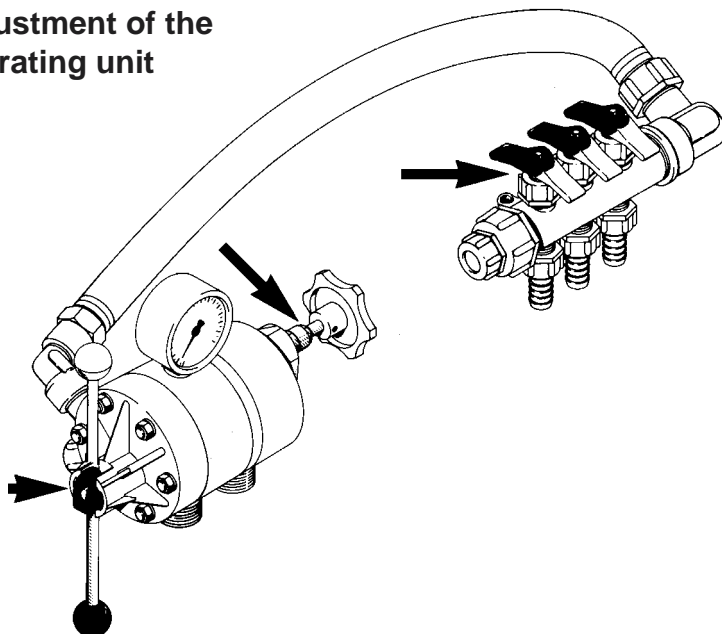

1. Turn main on/off handle **1** to off position **A**.
2. Set all hand levers on the distribution valve **2** to spraying position **A**.
3. Put the tractor in neutral and set the engine revolutions and thereby the number of revolutions of the pump corresponding to the intended travelling speed. Remember the number of revolutions on the P.T.O. must be kept between 300-600 r/min.
4. Turn main on/off handle **1** to spraying position **B**.
5. Now turn the pressure regulating valve **3** to until the required pressure is indicated on the pressure gauge.
6. Operating the control unit while driving:
To close the entire boom, turn the handle **1** to position **A**. This takes the pressure off the pump. The liquid will then return to the tank via the return system. The diaphragm anti-drip valves ensure instantaneous closing of all nozzles. In order to close part of the boom, move lever **2** of the distribution valve to position **B** (off position) for the section or sections to be closed. Note that the pressure will rise and readjustment will be necessary.

Drain valve operation

To open: **A**
To close: **B**

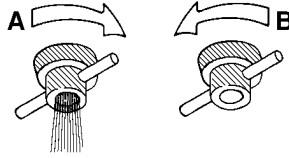

Maintenance

In order to derive full benefit from the sprayer for many years the following few but important rules should be kept:

Cleaning the Sprayer - see Spray Technique book.

Filters

Clean filters ensure :

- Sprayer components such as valves, diaphragms and operating unit are not hindered or damaged during operation.
- Nozzle blockages do not occur whilst spraying.
- Long life of pump. A blocked suction filter will result in pump cavitation.

The main filter protecting sprayer components is the suction filter at the top of the tank. Check it regularly. Ensure the O-ring on filter housing is in good condition and lubricated.

Also regularly check nozzle filters.

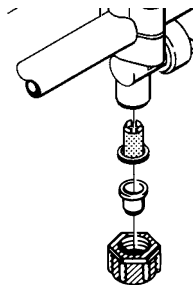
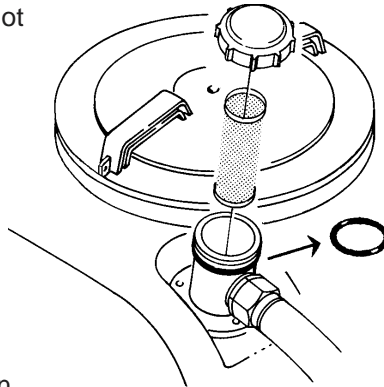



Lubrication

Recommended lubrication is shown in following tables. Use ball bearing grease (lithium grease No.2)

NOTE: If the sprayers are cleaned with a high pressure cleaner or it has been used to spray fertilizer, we recommend lubrication of the entire machine.

 **5** Position on sprayer

 Oil





 Grease



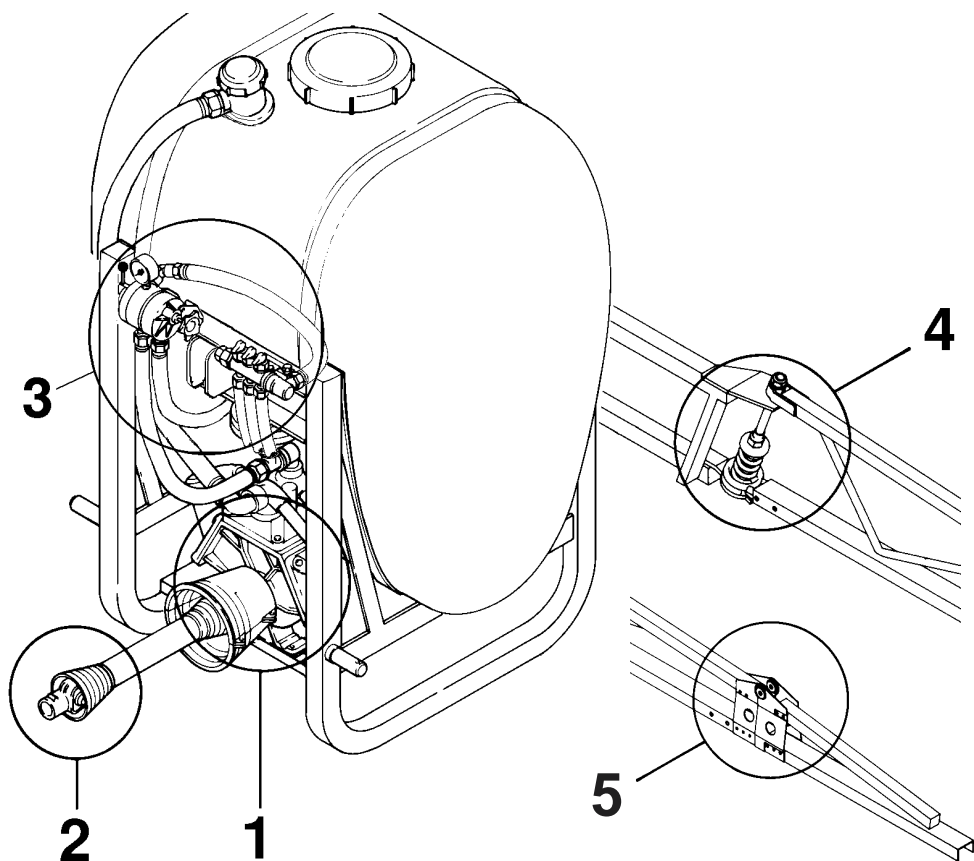

 Operation hours

 Page to find more information

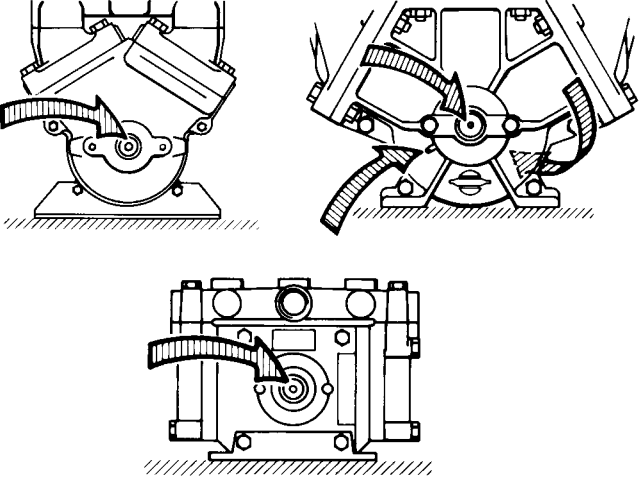
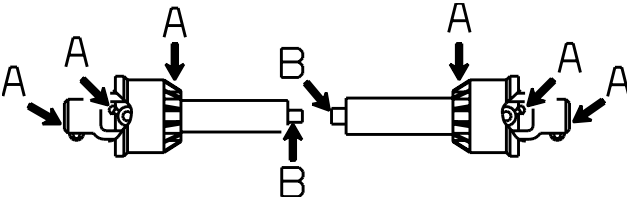
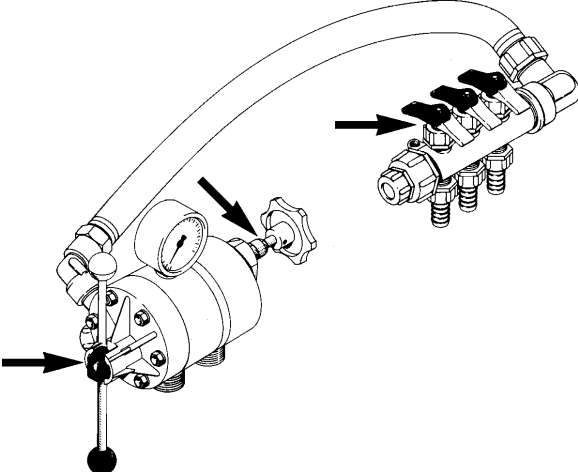
 Winter protection/
off-season storage

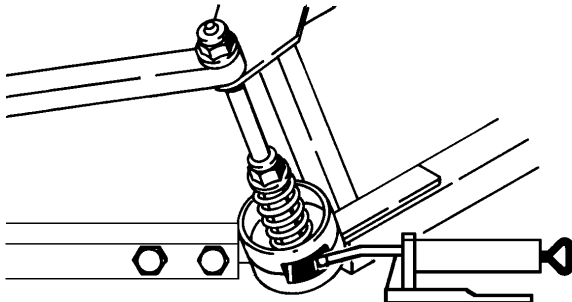
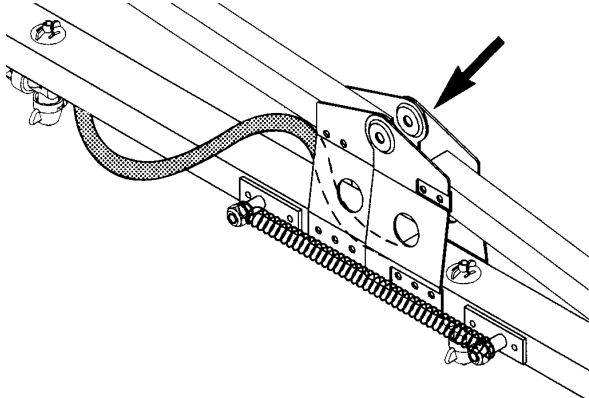

POS.					
1		X	40		16 17
2	A B	X X	12 40		17 6
3	X		20		10 19

POS.					
4		X	40		15
5	X		40		15

Re-adjustment of the boom

After having used the sprayer for some days the boom should be adjusted as follows:

When adjusting the sprayer must be on level ground with unfolded boom.

Boom breakaway

The function of the breakaway is to prevent or reduce boom damage if it should strike an object or the ground. If it is over-tight, it will not function. If it is too loose, it will yawn (forward and back movement) under spraying.

Lubricate coupling before adjusting spring tension. Slacken nut **A** to decrease breakaway resistance. Do not overtighten; better loose than over-tight. Minor adjustments in the field may be necessary. Ensure also channel bolts **B** are tight.

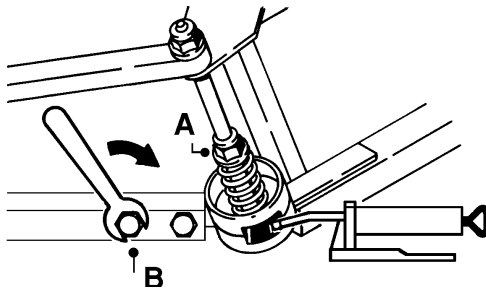

Outer section

The hinge should be firm. If tight it is difficult to fold. To adjust, tighten or loosen nuts **C**.

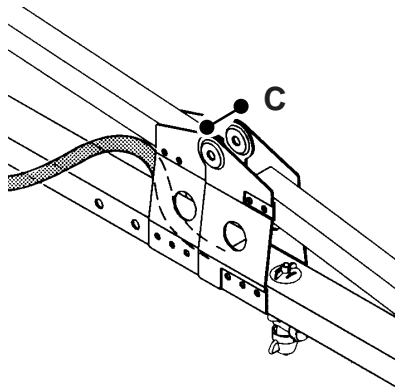



Changing of valves and diaphragms

Valves

Remove valve cover **1**. Before changing the valves **2** note the orientation of the valves so that they are replaced correctly.

It is recommended to use new gaskets **3** when changing or checking the valves.

Diaphragms

Remove the diaphragm cover **4** after having dismantled the valve cover. The diaphragm **5** may then be changed. If fluids have reached the crankcase, re-grease the pump thoroughly. Check also the drain hole at the bottom of the pump is not blocked.

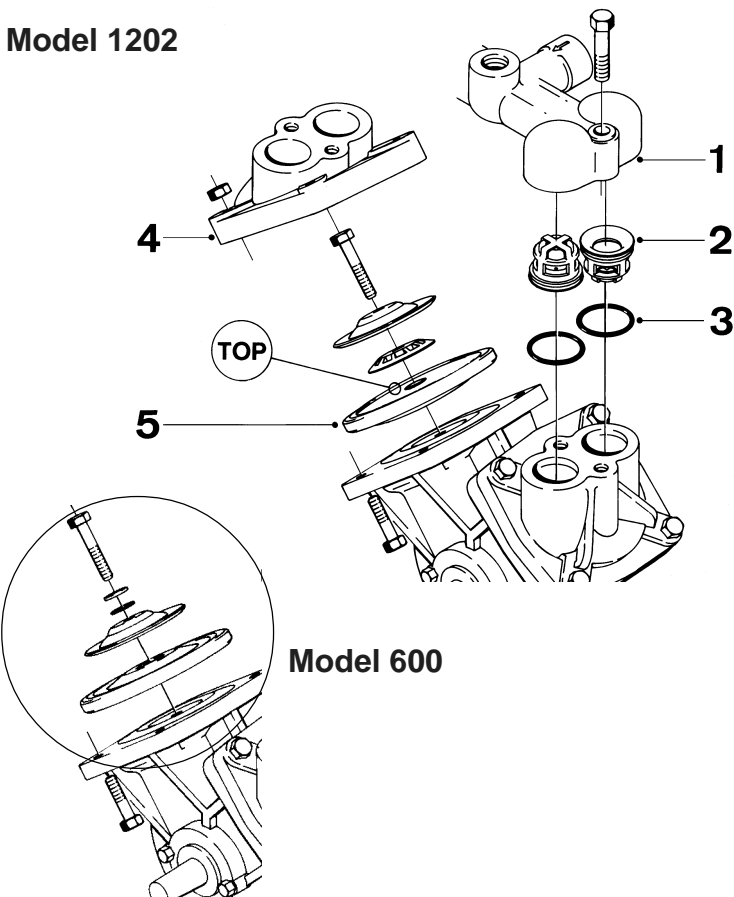

Model 1302

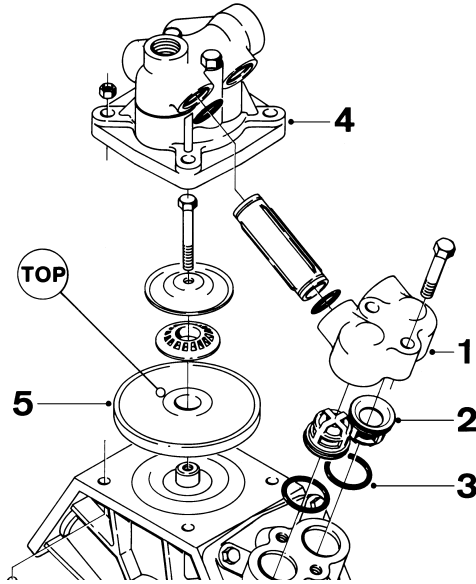

Model 320

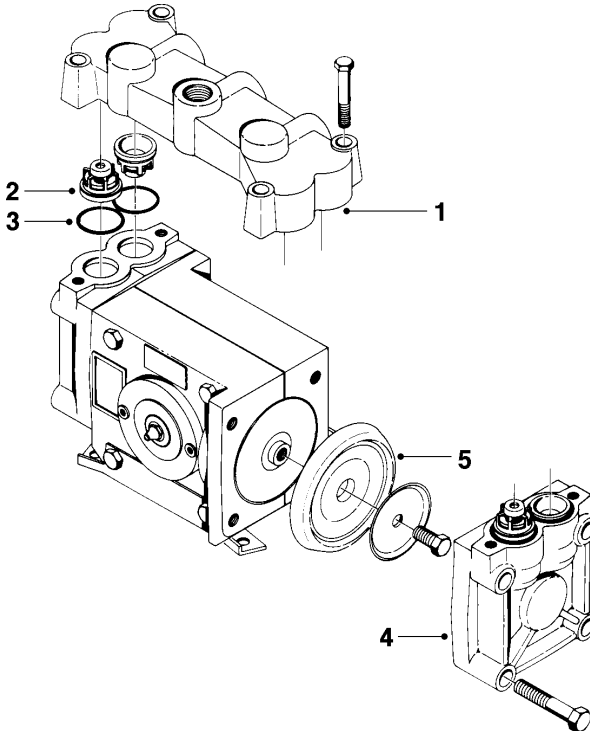



Nozzle tubes and fittings

Poor seals are usually caused by;

- . missing O-rings or gaskets
- . damaged or incorrectly seated O-rings
- . dry or deformed O-rings or gaskets
- . foreign bodies

Therefore, in case of leaks: **DO NOT** over-tighten. Disassemble, check condition and position of O-ring or gasket, clean lubricate and reassemble.

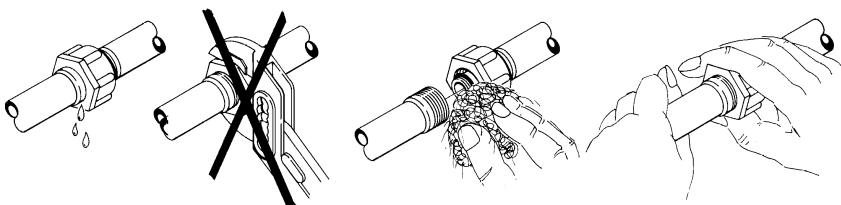
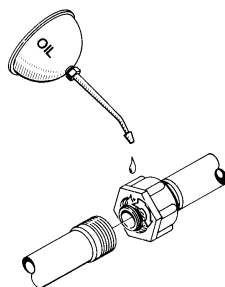

For **radial** connections only hand tighten them.

The O-ring to be lubricated **ALL THE WAY ROUND** before fitting on to the nozzle tube.

For **axial** connections, a little mechanical leverage may be used.

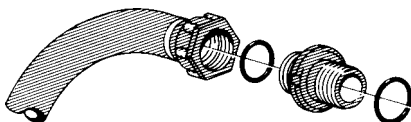

Off-season storage

When the spraying season is over you should devote some extra time to the sprayer before it is put away for the winter.

Hoses

Check that none of the hoses are caught or have sharp bends.

A leaky hose can give an annoying delay in the middle of the spraying job. Therefore check all the hoses and change if there is any doubt about the durability.

Paint

Some chemicals are very hard on paints. It is therefore well advised to remove rust, if any, and then touch up the paint.

Tank

Check that no chemical residues are left from the last spraying. Chemical residues must not be left in the tank for a long time. It will reduce the life of the tank. See Spray Technique book - Cleaning the sprayer.

Operating unit

Take care that the pressure regulation valve is completely loosened. The spring is thereby relieved and operation difficulties are avoided at start-up next season.

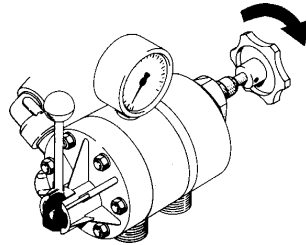

Transmission shaft

Check that the transmission shaft fulfills its security purpose, e.g. that shields and protective tubes are intact.

Anti-freeze precaution

If the sprayer is not stored in a frost-proof place you should take the following precautions: Put at least 10 litres of 33% anti-freeze mixture in the tank and let the pump run a few minutes so that the entire system including spray hose are filled. Remove the glycerine filled pressure gauge and store it frost free in vertical position. The anti-freeze solution also hinders the O-rings and gaskets from drying out.





Operational problems

In cases where breakdowns have occurred the same factors always seem to come into play:

- Minor leaks on the suction side of the pump will reduce the pump capacity or stop the suction completely.
- A clogged suction filter will hinder or prevent suction so that the pump does not operate satisfactorily.
- Clogged up nozzle filters will result in increasing pressure at the pressure gauge but lower pressure at the nozzles.
- Foreign bodies stuck in the pump valves with the result that these cannot close tightly against the valve seat. This reduces pump efficiency.
- Poorly reassembled pumps, especially diaphragm covers will allow the pump to suck air resulting in reduced or no capacity.

Therefore **ALWAYS** check:

1. Suction and nozzle filters are clean.
2. Hoses for leaks and cracks, paying particular attention to suction hoses.
3. Gaskets and O-rings are present and in good condition.
4. Pressure gauge is in good working order. Correct dosage depends on it.
5. Operating unit functions properly. Use clean water to check.



Fault	Probable cause	Control / remedy
Liquid system		
No spray from boom when turned on.	Air leak on suction.	Check if red suction lid/O-ring are sealing. Check suction tube and fittings. Check tightness of pump diaphragm and valve covers.
	Air in system.	Fill suction hose with water for initial prime.
	Suction/nozzle filters clogged.	Clean filters. Check yellow suction pipe is not obstructed or placed too near the tank bottom.
Lack of pressure.	Pump valves blocked or worn.	Check for obstructions and wear.
	Defect pressure gauge.	Check for dirt at inlet of gauge.
Pressure dropping.	Filters clogging.	Clean all filters. Fill with cleaner water.
	Nozzles worn.	Check flow rate and replace nozzles if it exceeds 10%.
	Tank is airtight.	Check vent is clear.
Pressure increasing	Nozzle filters beginning to clog.	Clean all filters.
Formation of foam.	Air is being sucked into system.	Check tightness / gaskets / O-rings of all fittings on suction side.
	Excessive liquid agitation.	Reduce pump r/min. Use foam damping additive.
Liquid leaks from bottom of pump.	Damaged diaphragm.	Replace. See Changing of valves and diaphragms.

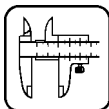

Technical specifications

Measure and weights

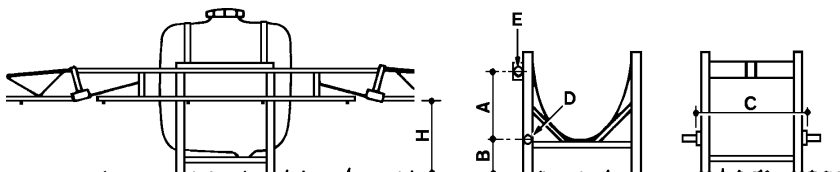

Tank size l	Boom height		A mm	B mm	C mm	D ø mm	E ø mm
	Min. H mm	Max. H mm					
300	145	545	490	229	625	22	26
400	131	531	476	229	645	22	26
600	95	575	589	235	645	22	26
800	140	620	634	230	825	28	26

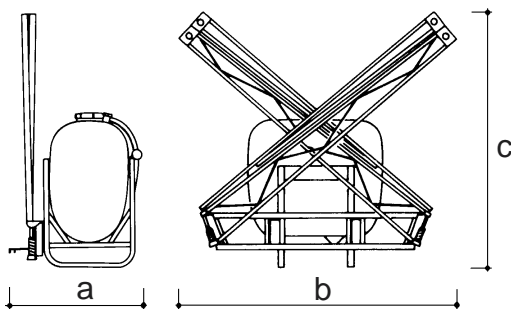

Tank size l	With boom				Without boom		
	Spraying width m	Pump model	Measure a x b x c cm	Weight kg	Pump model	Measure a x b x c cm	Weight kg
300	6	600	140 x 190 x 170	140	600	70 x 83 x 120	99
	8	600	140 x 190 x 210	146	320	70 x 83 x 120	107
400	8	600	140 x 190 x 210	156	600	70 x 98 x 132	106
	10	1202	140 x 190 x 210	171	320	70 x 98 x 132	114
600	8	600	140 x 190 x 210	173	600 1202 1302 320	77 x 119 x 139	123
	8	1202	140 x 190 x 210	184		77 x 119 x 139	131
	10	1202	140 x 190 x 210	191		77 x 119 x 139	142
	10	1302	140 x 190 x 210	197		77 x 119 x 139	132
800	12	1302	140 x 256 x 260	209	1302	77 x 160 x 143	163
	10	1302	140 x 190 x 210	223			
	12	1302	140 x 256 x 260	235			

Power consumption and capacity

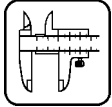

600/7.0		r/min									
		300		400		500		540		600	
bar	l/min	kW	l/min	kW	l/min	kW	l/min	kW	l/min	kW	
0	20,5	0,15	30,0	0,22	39,0	0,29	42,0	0,30	47,0	0,37	
5	16,5	0,29	22,5	0,45	28,5	0,52	30,5	0,59	34,0	0,67	
10	16,5	0,45	22,0	0,59	27,5	0,82	30,0	0,89	33,0	0,97	
15	16,0		21,0		26,5		28,0		32,0		
Rotation per min.	r/min	Capacity				l/min	Suction height				0,0 m
Power consumption	kW	Max. pressure				15bar	Weight				15,6 kg

1202/9.0		r/min									
		300		400		500		540		600	
bar	l/min	kW	l/min	kW	l/min	kW	l/min	kW	l/min	kW	
0	56	0,91	72	1,28	93	1,52	99	1,63	112	1,79	
5	40	1,11	53	1,36	66	1,60	71	1,71	79	1,86	
10	38	1,38	52	1,74	64	1,79	69	1,87	77	2,07	
15	37	1,60	50	1,97	62	2,32	67	2,48	75	2,76	
Rotation per min.	r/min	Capacity				l/min	Suction height				0,0 m
Power consumption	kW	Max. pressure				15bar	Weight				24,0 kg

1302/9.0		r/min									
		300		400		500		540		600	
bar	l/min	kW	l/min	kW	l/min	kW	l/min	kW	l/min	kW	
0	63	0,90	84	1,19	103	1,51	114	1,61	125	1,80	
5	58	0,94	79	1,29	96	1,61	105	1,75	116	1,93	
10	56	1,30	76	1,80	94	2,30	101	2,48	111	2,72	
15	55	1,80	74	2,22	93	2,92	99	3,18	109	3,54	
Rotation per min.	r/min	Capacity				l/min	Suction height				0,0 m
Power consumption	kW	Max. pressure				15bar	Weight				35,0 kg

320/7.0		r/min									
		300		400		500		540		600	
bar	l/min	kW	l/min	kW	l/min	kW	l/min	kW	l/min	kW	
0	24		33		44		51		59		
5	22		30		37		40		45		
10	21		29		36		39		44		
15	21		29		36		38		43		
20	20		28		35		37		42		
25	20		27		35		37		42		
Rotation per min.	r/min	Capacity				l/min	Suction height				0,0 m
Power consumption	kW	Max. pressure				25bar	Weight				23,7 kg

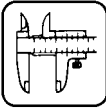

Filters and nozzles

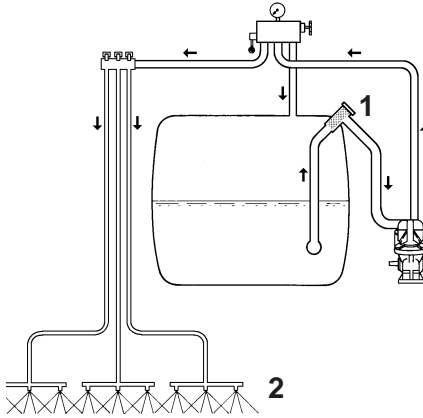

Pos.	Mesh/ colour	Description/ nozzle
1	30	Suction filter
2	50 blue	Nozzle 4110-20



Pictorial symbols



Description



Pressure



Function



Cleaning



Connection



Lubrication



Warning



Winter storage



Operating



Operational problems



Service/adjustment



Technical specifications



Liquid flow

Assembly



Preassembly information

The sprayer is supplied ex-works in shipping packages (SP). Number of SP's per sprayer varies depending on model.

As this covers all NL models, please note the fittings covering exactly your model.

NOTE:

Removal of the plastic bag covering the tank is easiest done before assembly.

Some components are shipped within the tank. Check inside.

To verify connection of hoses, a function diagram is included on page 32.

Packaging information

Materials used for packaging are environmentally compatible. They can be safely deposited or they can be burnt in an incinerator.

Recycling

Cardboard: Can recycle up to 99% and therefore should be put into the waste collection system.

Polystyrene foam: Can be recycled. Fluorocarbons (CFC) not used in foam production.

Polyethylene: Can be recycled.

Model
600
1202
320

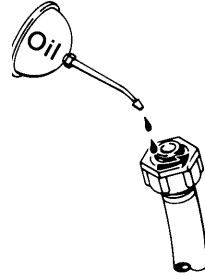
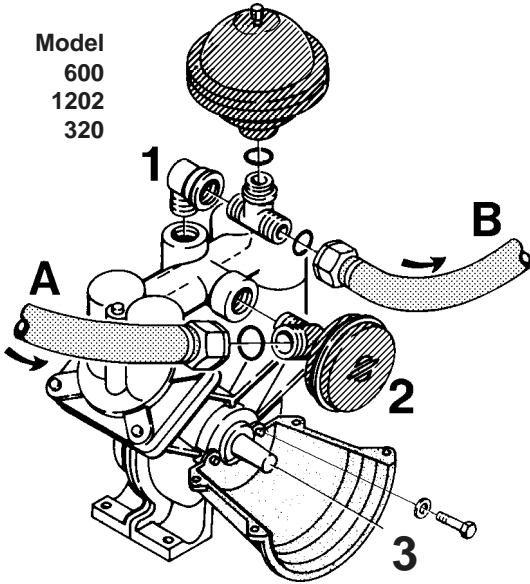

NOTE: Use O-rings where indicated. Lubricate them before assembly. Where O-rings are not indicated, use sealing tape.

1. Fit pulsation damper and pressure hose **B**.
2. Fit suction damper and suction hose **A**.
3. Fit bottom half of yellow protective guard. Remember washer.

Model
1302

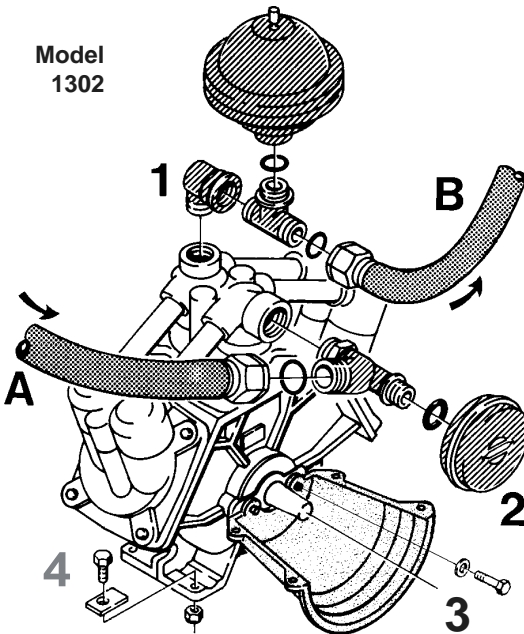

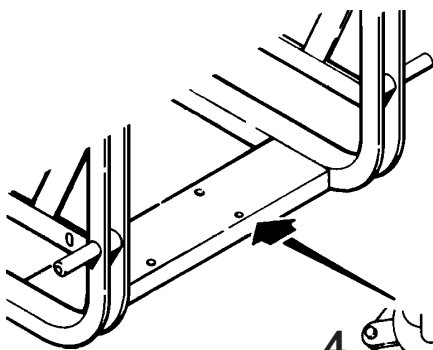

4. Bolt pump to console. Position pulsation damper so it fits into cavity.
5. Lubricate conical shaft lightly and connect transmission shaft. Attach chain to prevent rotation of the protective guard.

Recheck the grub screw is tight after 5 min. of usage.

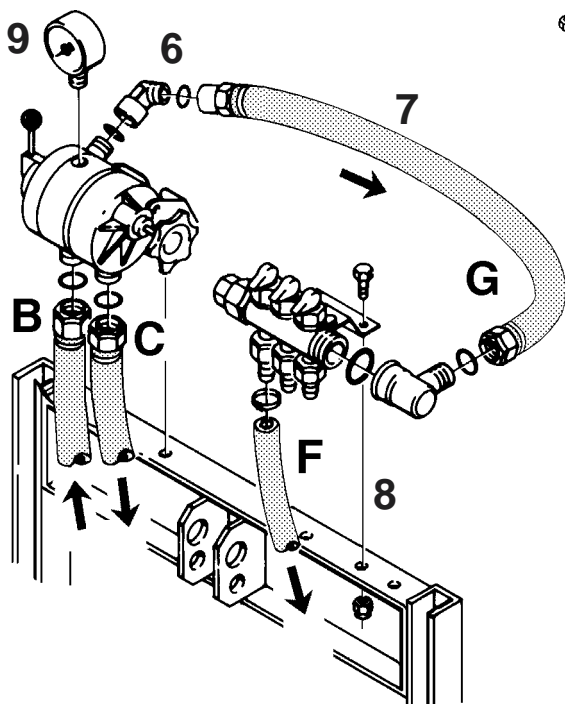
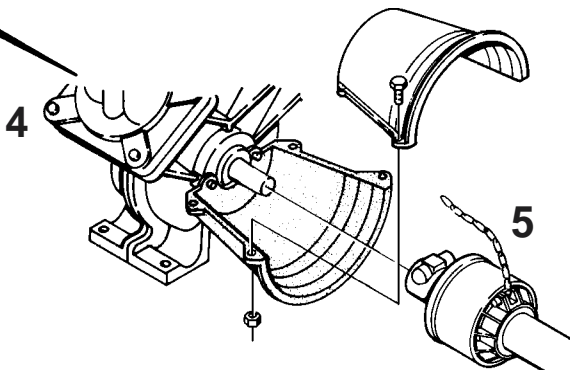

6. Fit 45° elbow to on/off unit. Use O-rings and sealing tape.
7. Connect on/off unit to distribution valves.
8. Bolt to top section.
9. Screw pressure gauge on to on/off unit. Do not overtighten. See back of gauge. Remember to pierce casing after installation.
10. Fit hoses. Remember to lubricate O-rings before fitting.

- B** = From pump.
- C** = Return to tank.
- F** = Feed hoses to boom. For 12 metre boom, shortest hose is for centre section.
- G** = From on/off unit to distribution valves.

11. Fit hoses. Remember to lubricate O-rings before fitting.

A = Suction hose to pump.
C = Return to tank.

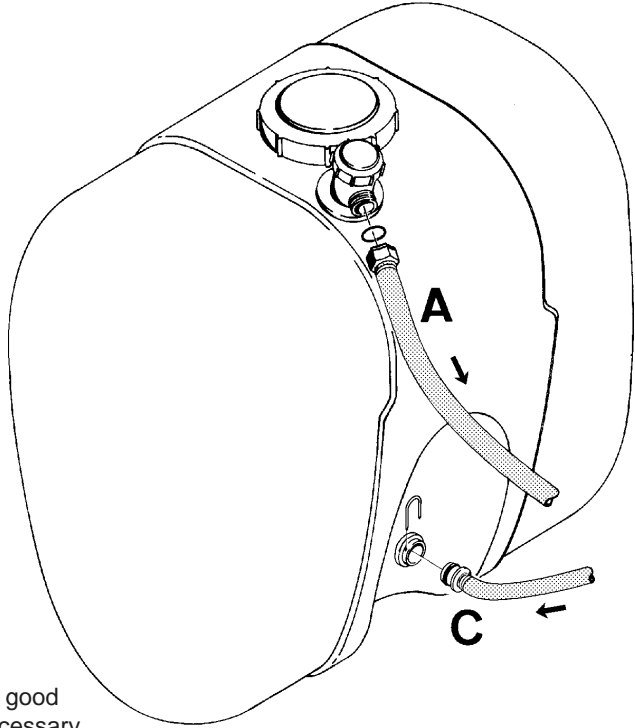

NOTE: For sake of good order, it may be necessary to shorten some hoses (for example, suction hose A). This is best done when assembly is completed and before hoses are secured with plastic straps.

800 I

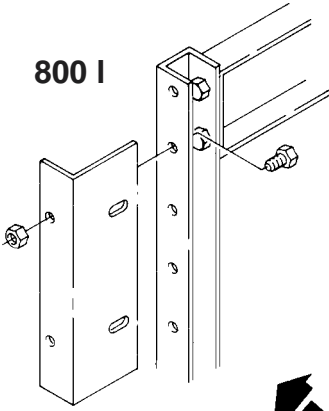

12. Tighten black metal tank straps if loose.

13. Bolt angle brackets to frame.

14. Fit boom centre.

15. Fit U-profile.

16. Fit boom wings. Be cautious when folding boom for the first time.

See section on Boom breakaway.

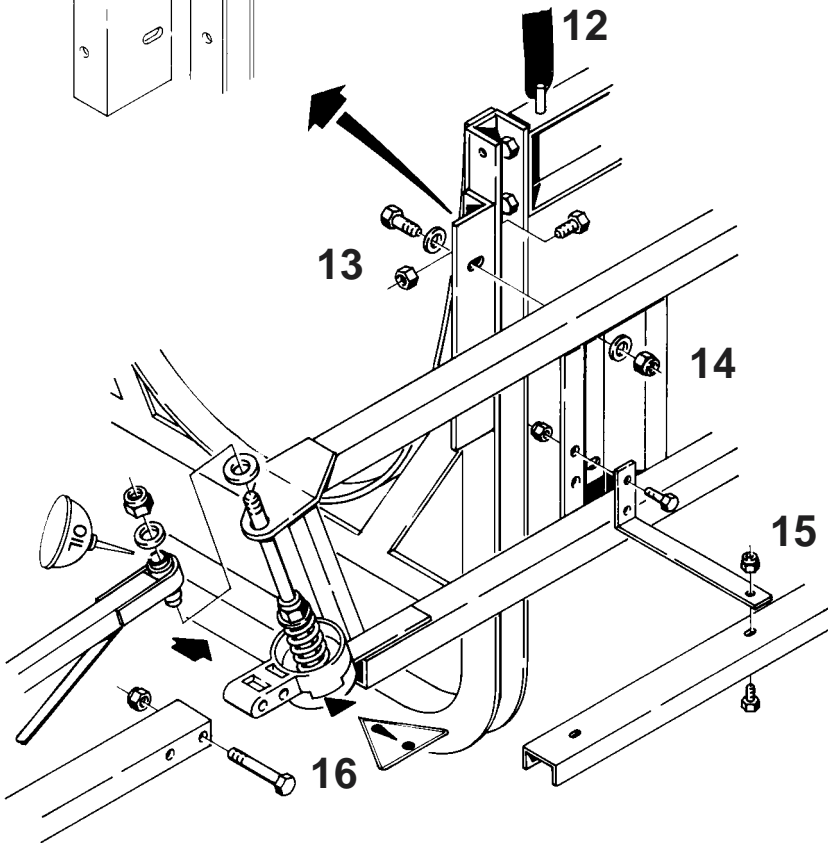

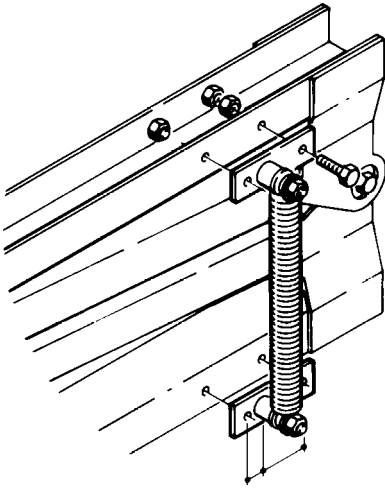

17. For 10 and 12 metre booms, fit outer section springs.
Note orientation of spring anchor.

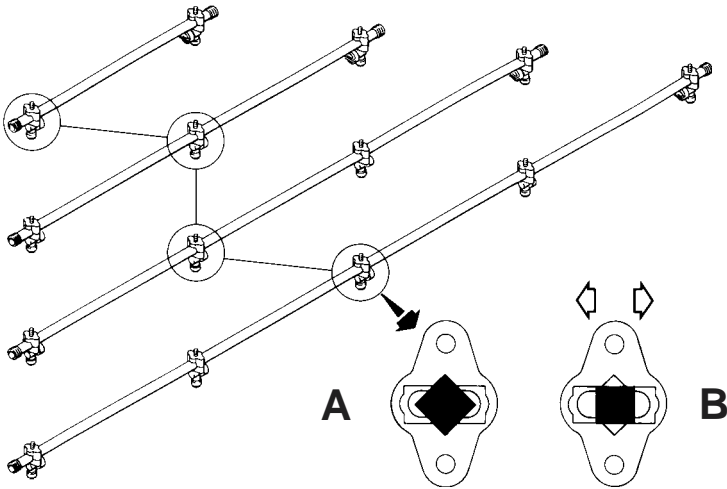

18. Nozzle tubes are supplied with one lock nozzle saddle per tube **A**. The rest can slide lengthwise **B** allowing for extension and contraction.

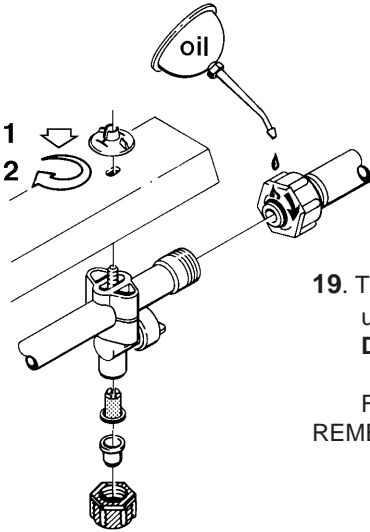

19. Tubes and hoses are connected. Fit tubes using synthetic nut. Press down **1**, turn **2**. **Do not over-tighten.**

Fit filter and nozzle.
REMEMBER: Lubricate O-rings before fitting.

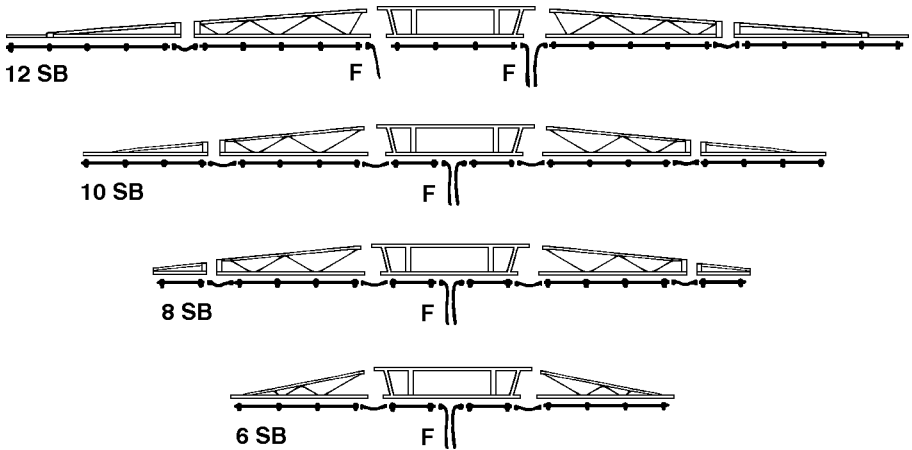

20. Fit boom transport lock.
Arrow indicates forward
direction of travel.

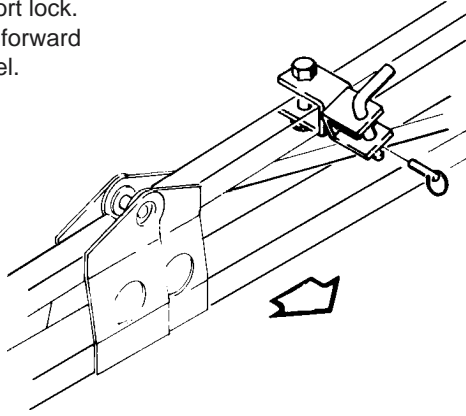

21. Verify connections with
diagram.

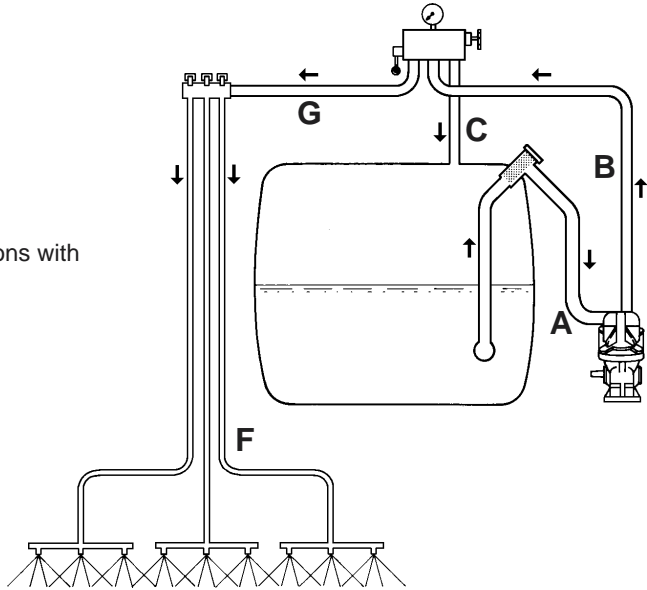

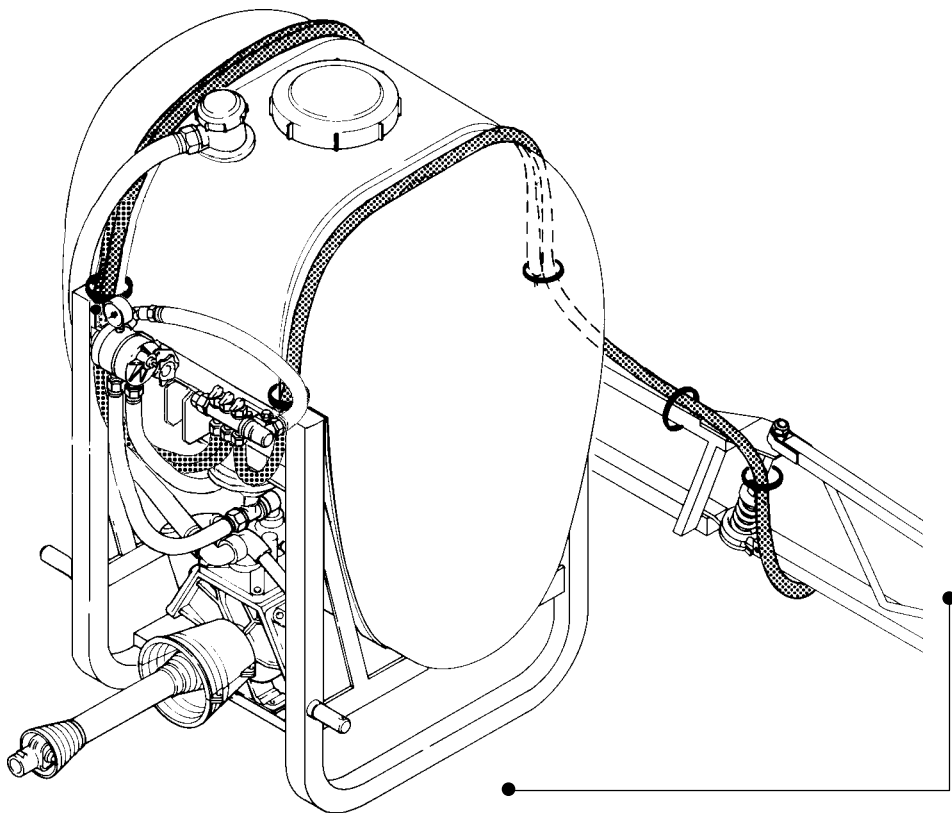

22. Organise hoses; it may be necessary to shorten some of them. Secure with straps.

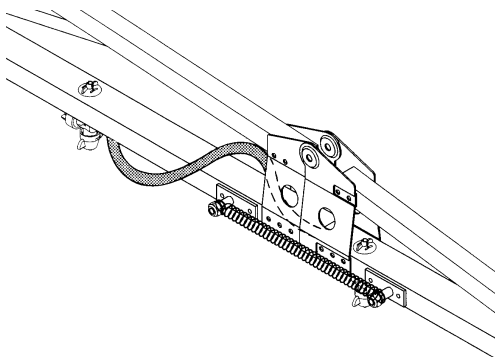

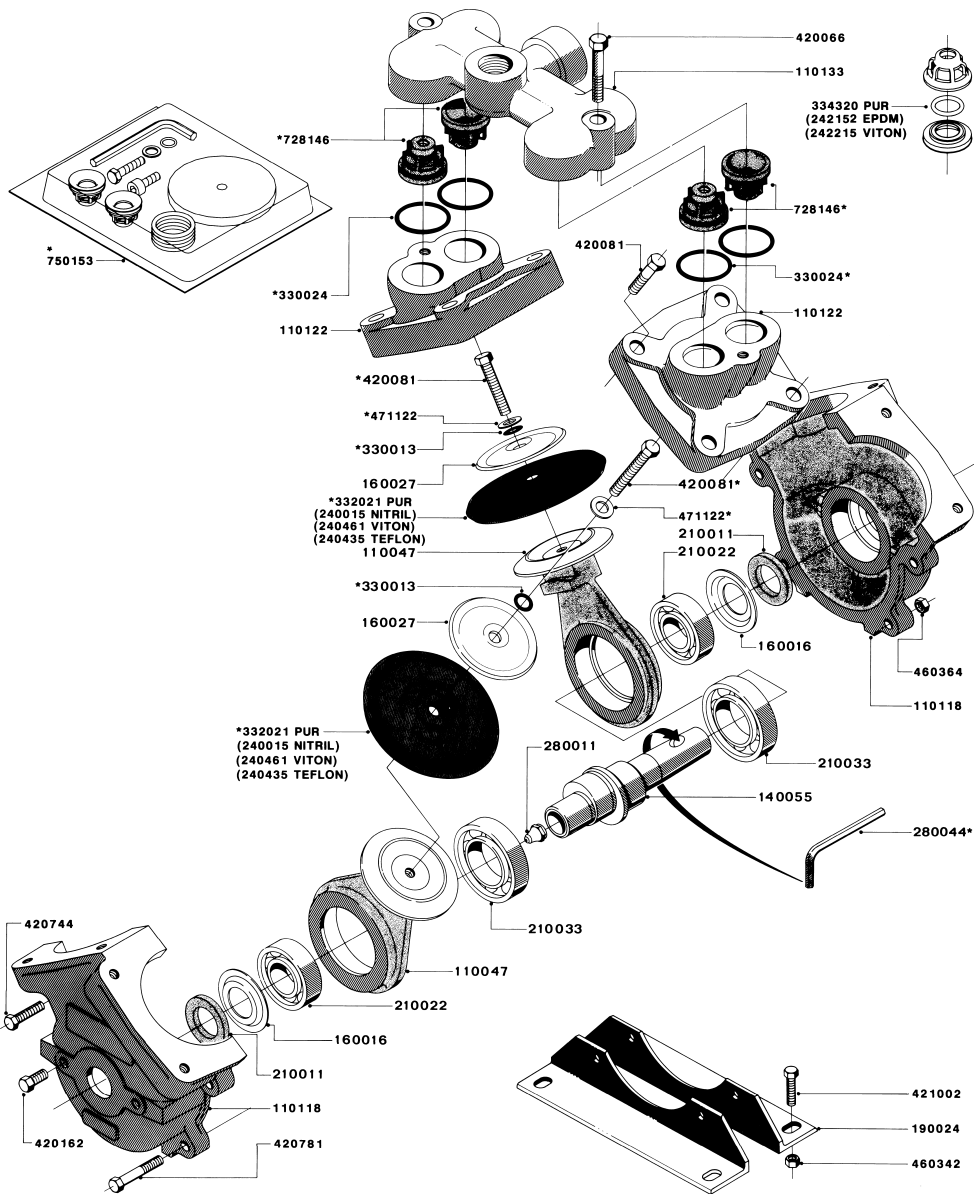

A6

600/foot

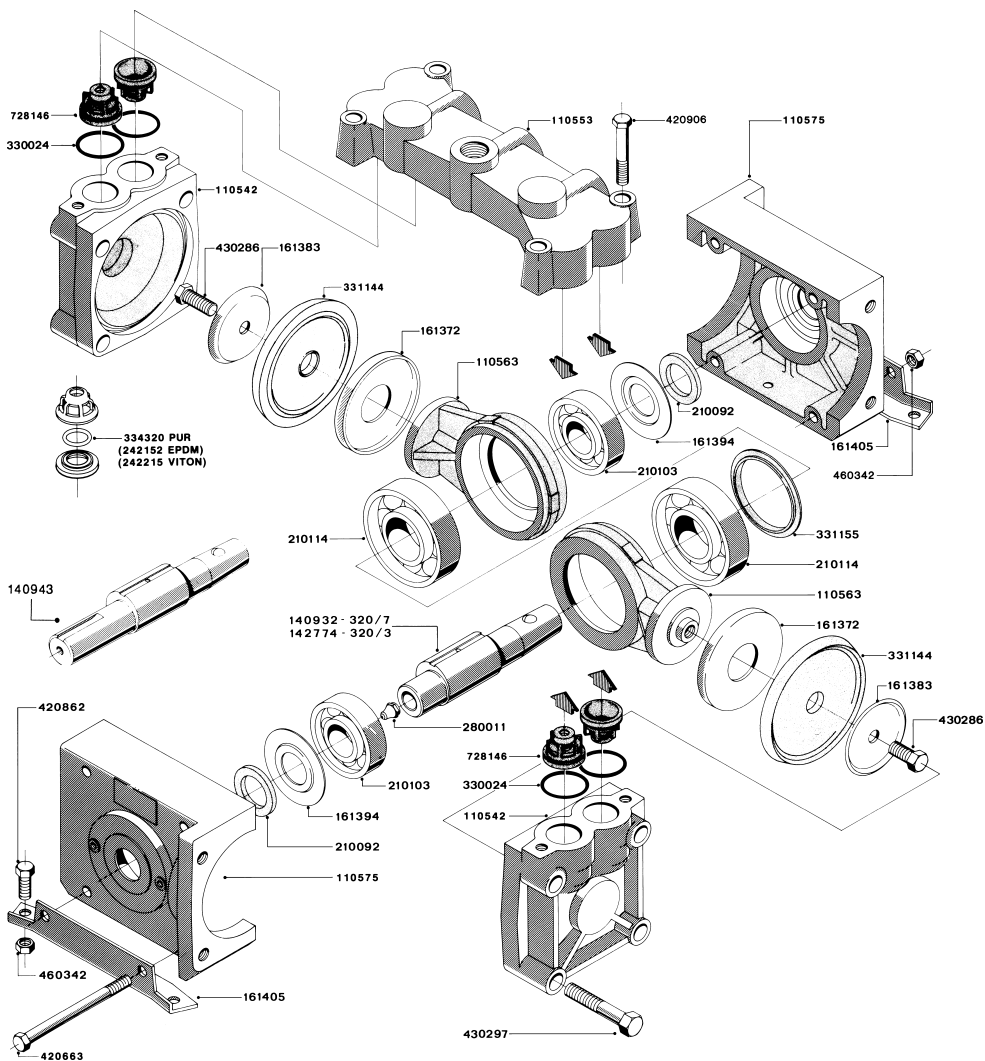

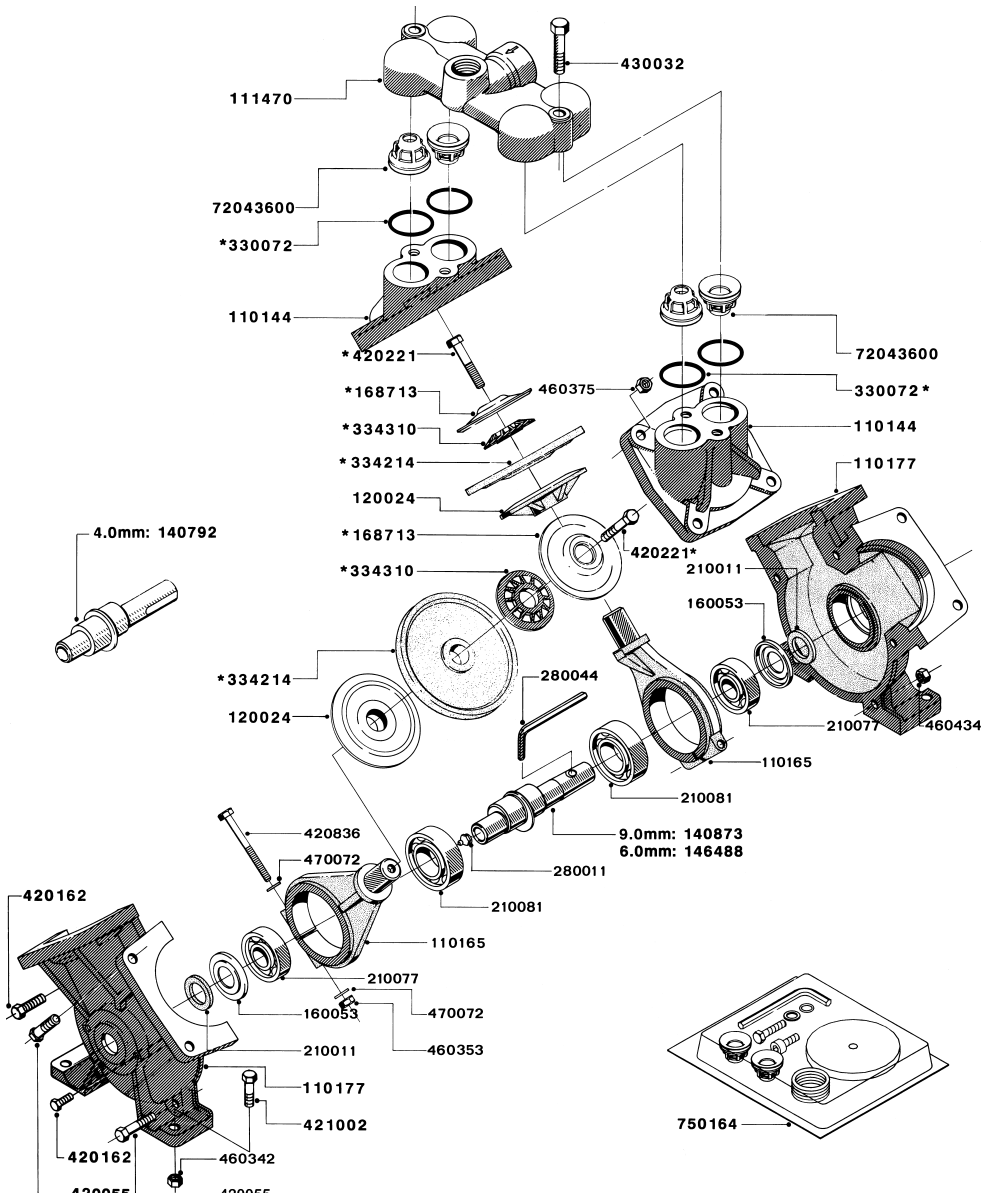

A10

1202/foot

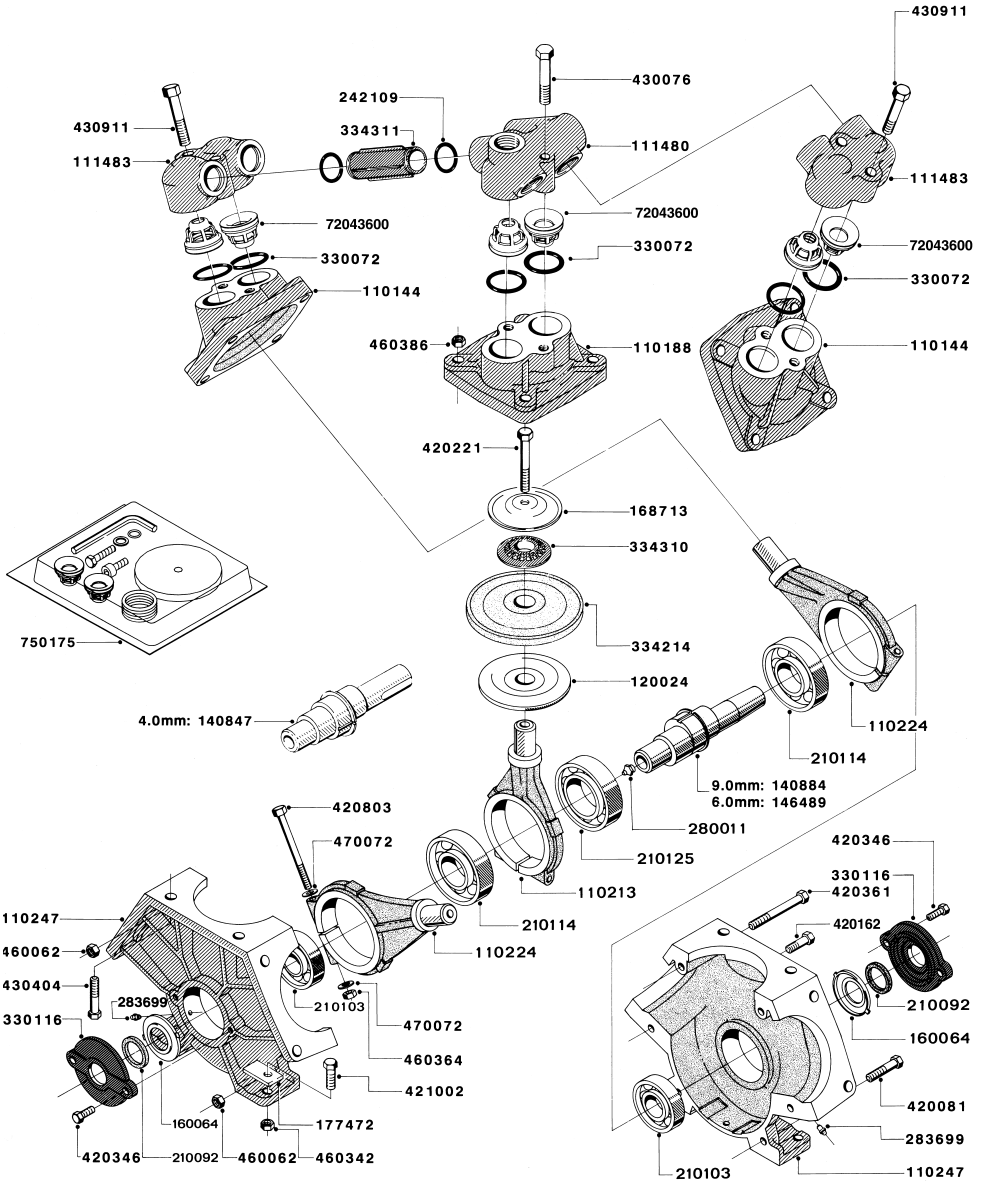

1303/foot

A12

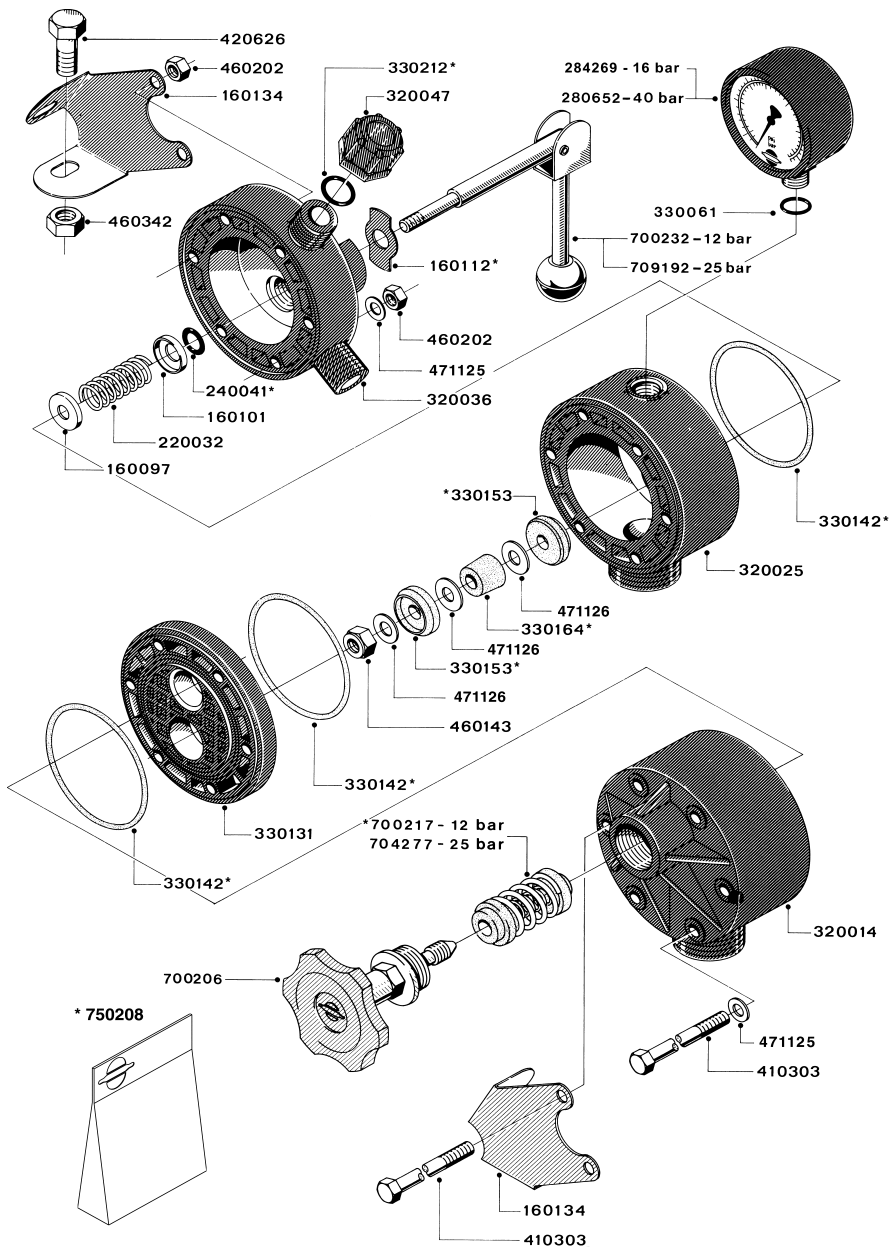

08.11.2000

B5

Unit M-70/70 HT

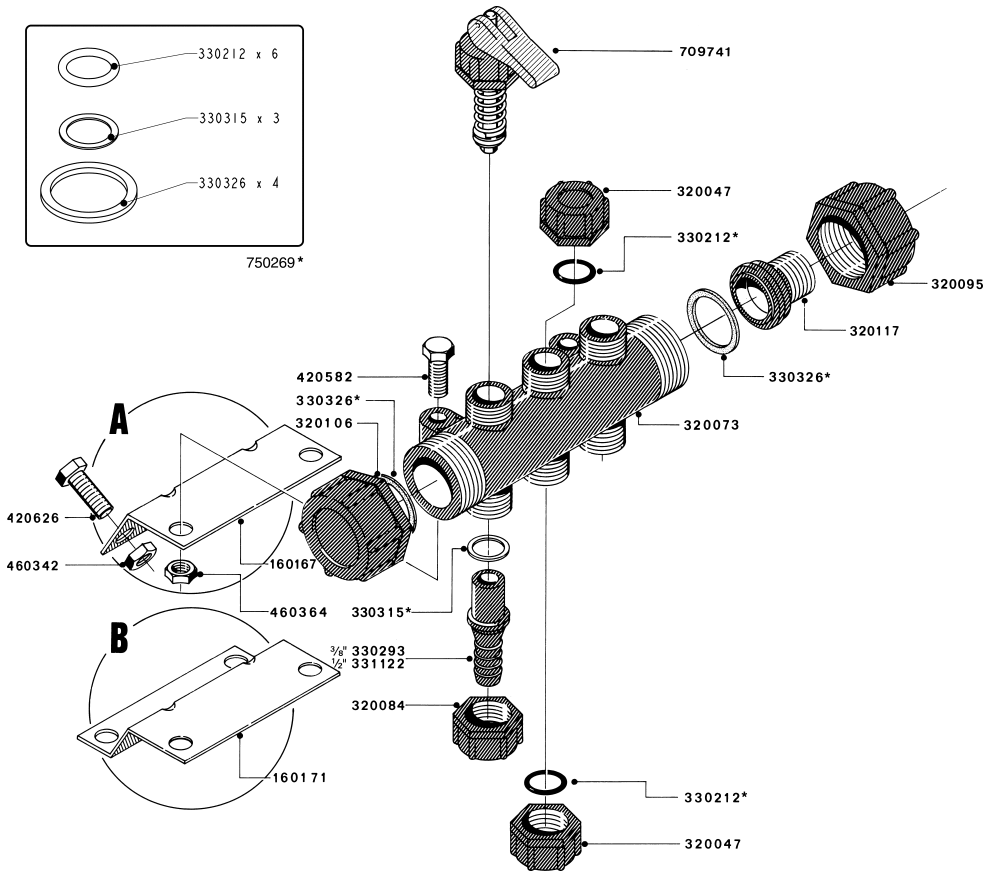

Distributor

B6

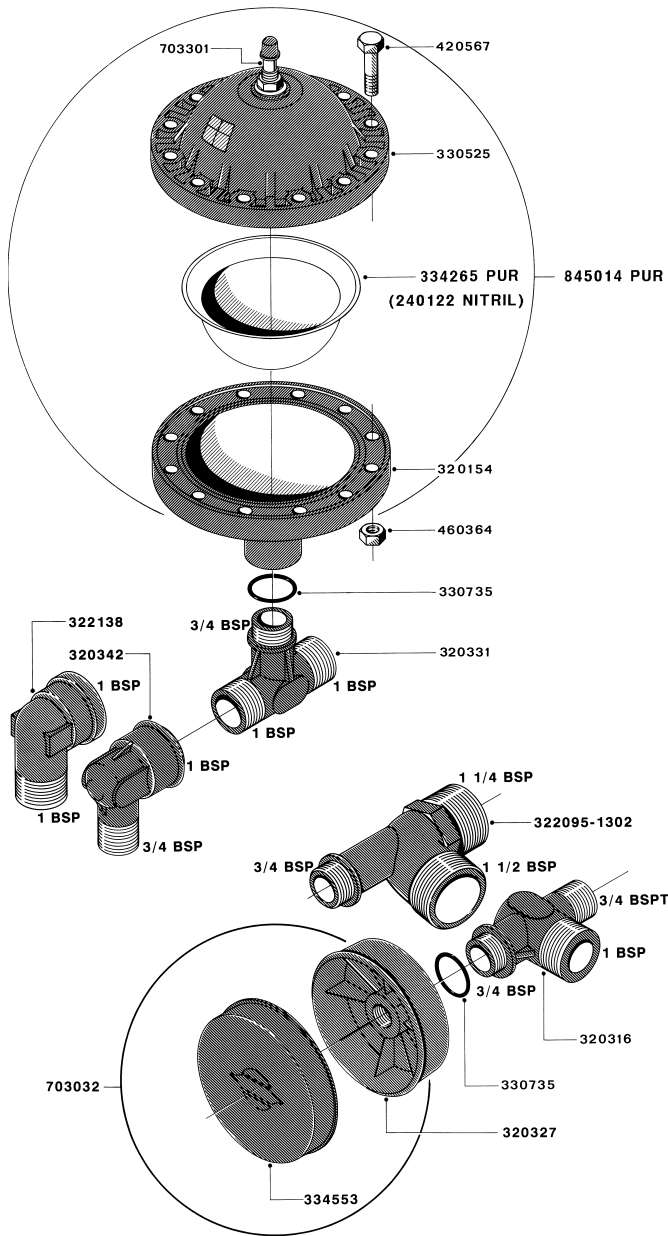

B300

Damper HJ73

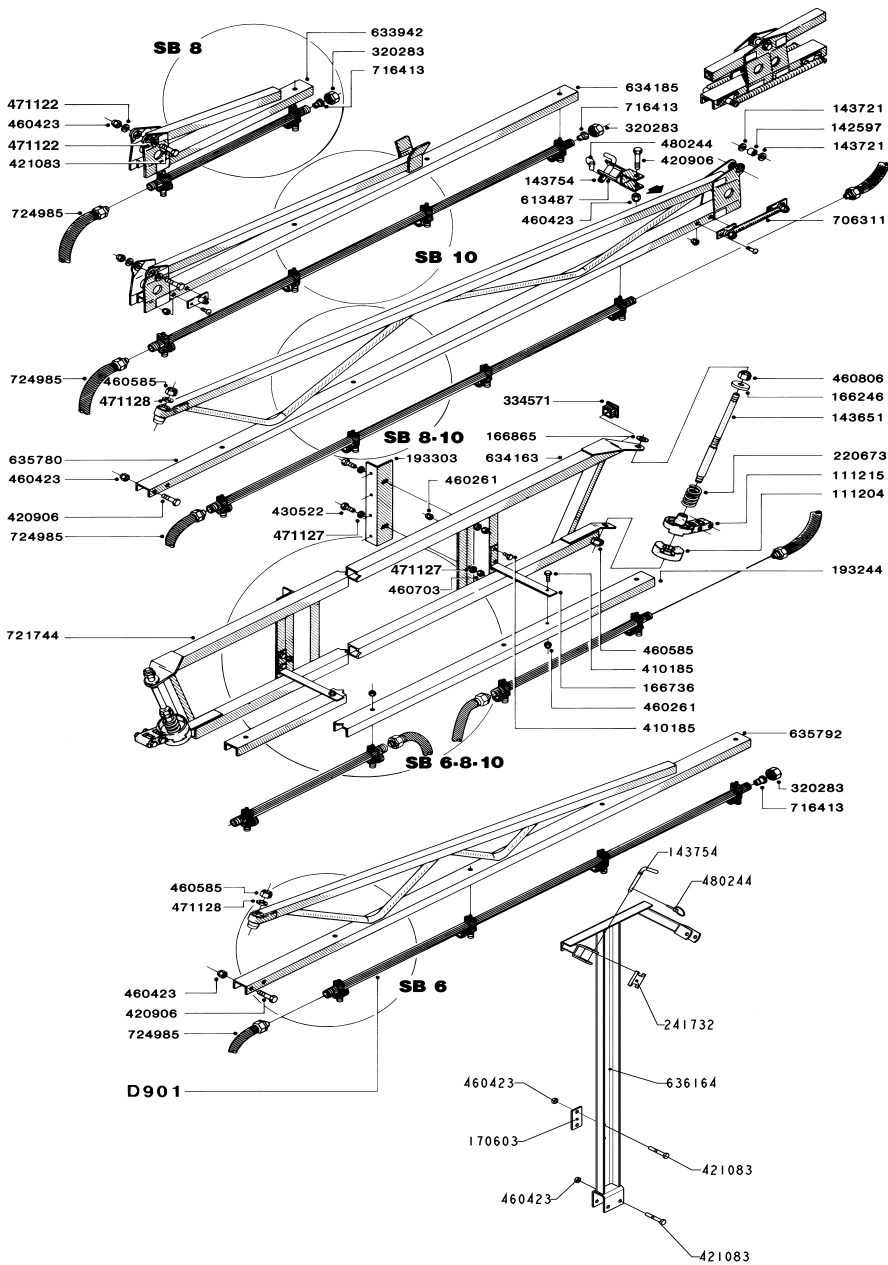

31.08.2000

SB 6/8/10 m

D3

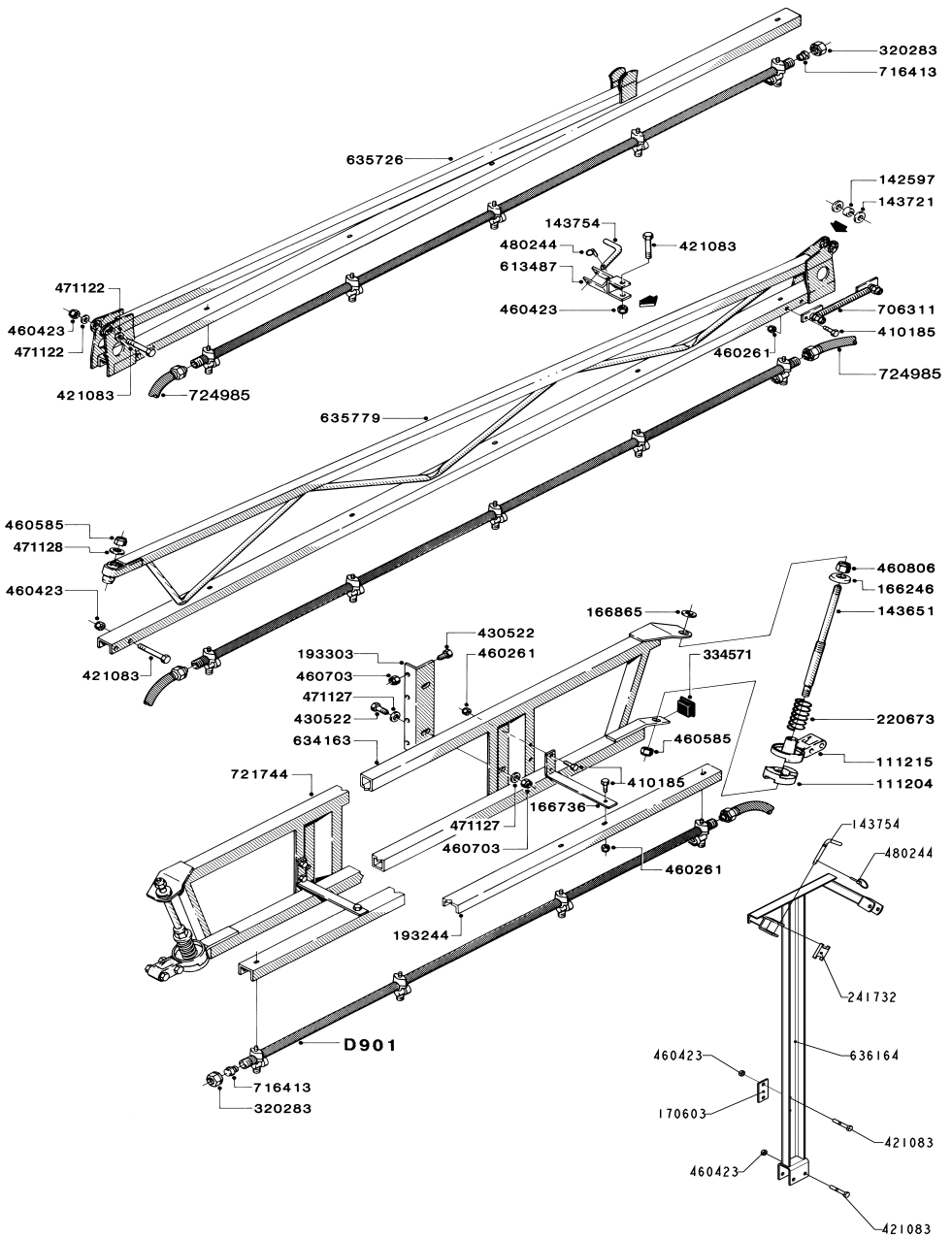

31.08.2000

D5

SB 12 m

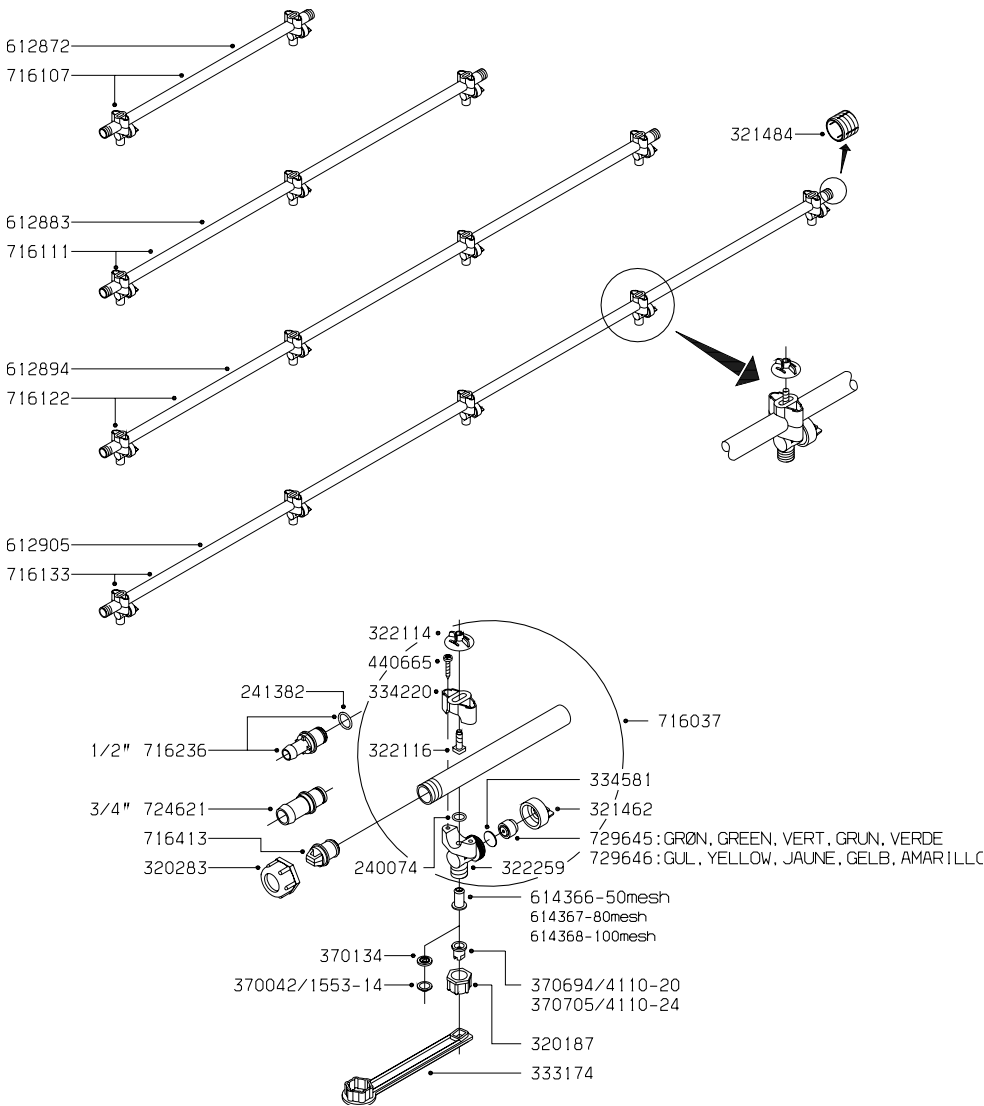

Boom tube 3/8" cap

D901

NL300 - 726865
 NL400 - 726867

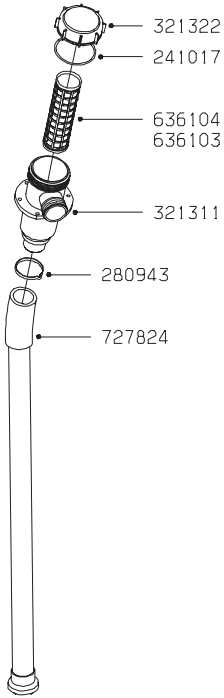
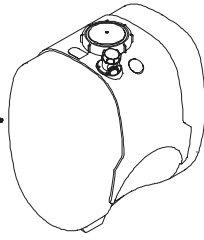

321322
 241017
 636104 (30 MESH)
 636103 (50 MESH)

321311
 280943

727824

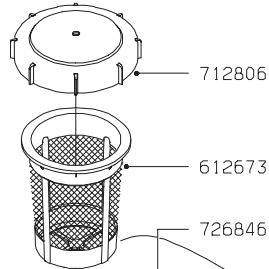

712806
 612673
 726846

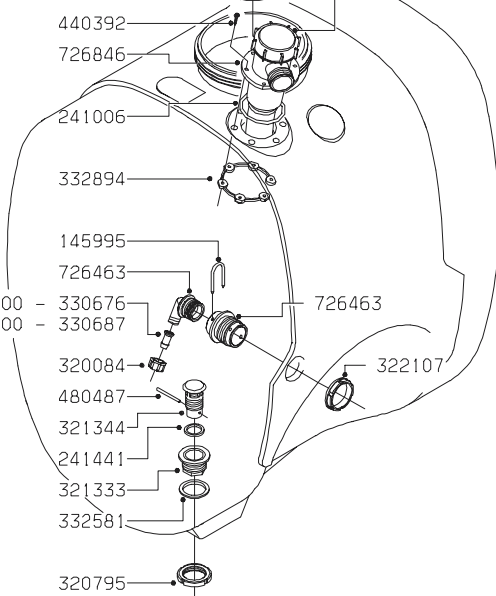

440392
 726846
 241006

332894

145995
 726463

NL300 - 330676
 NL400 - 330687

320084
 480487
 321344
 241441
 321333
 332581

726463
 322107

320795

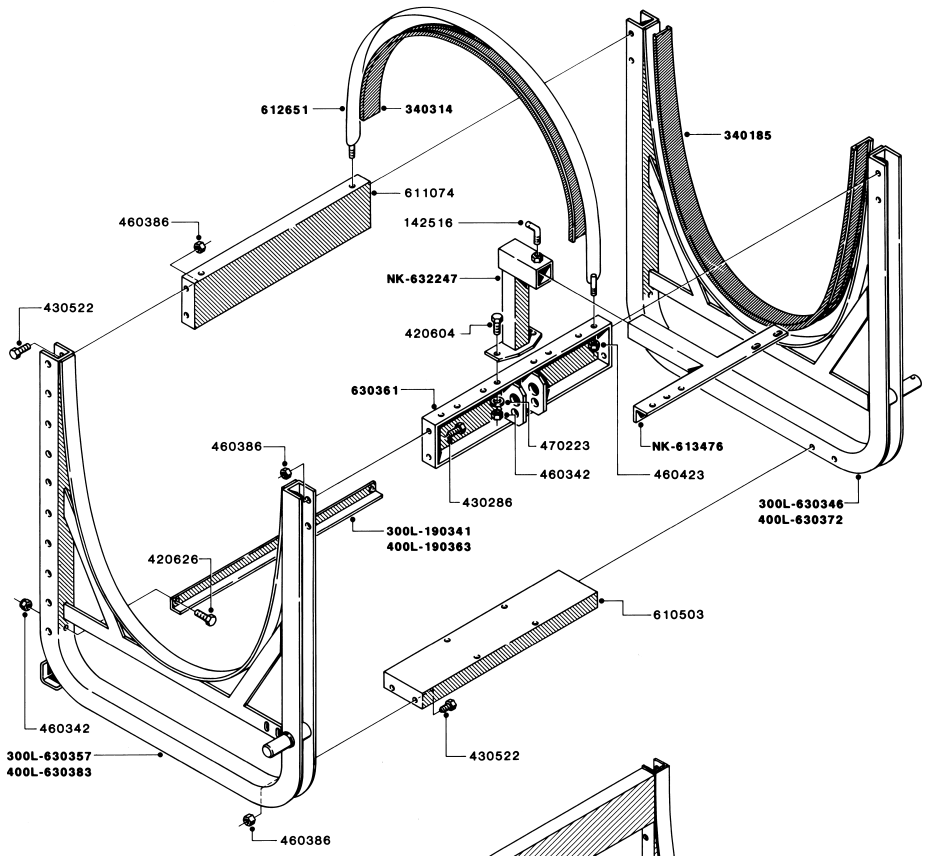

EFTER, AFTER, APRES, NACH, DESPUES: 01.08.93
 300L: 637351
 400L: 637352

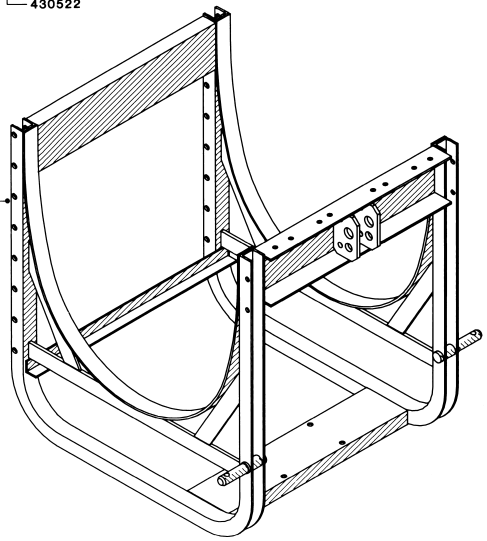

NL/NK 300/400

E102

600L-16033800
45000400
800L-16033500
45000400

EFTER, AFTER, APRES,
NACH, DESPUES: 01.08.93
600L:637353
800L:637354

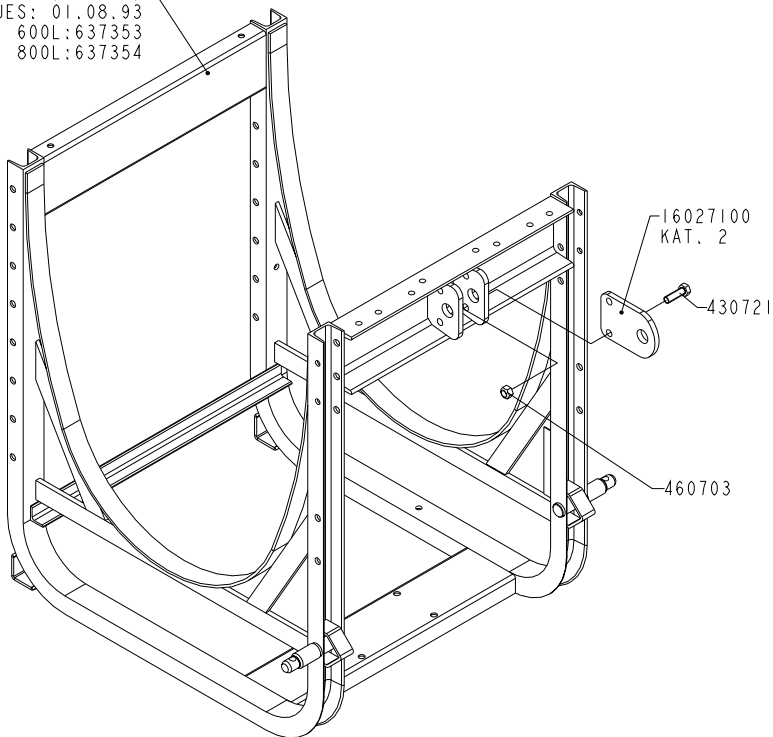

E103

NL/NK 600/800

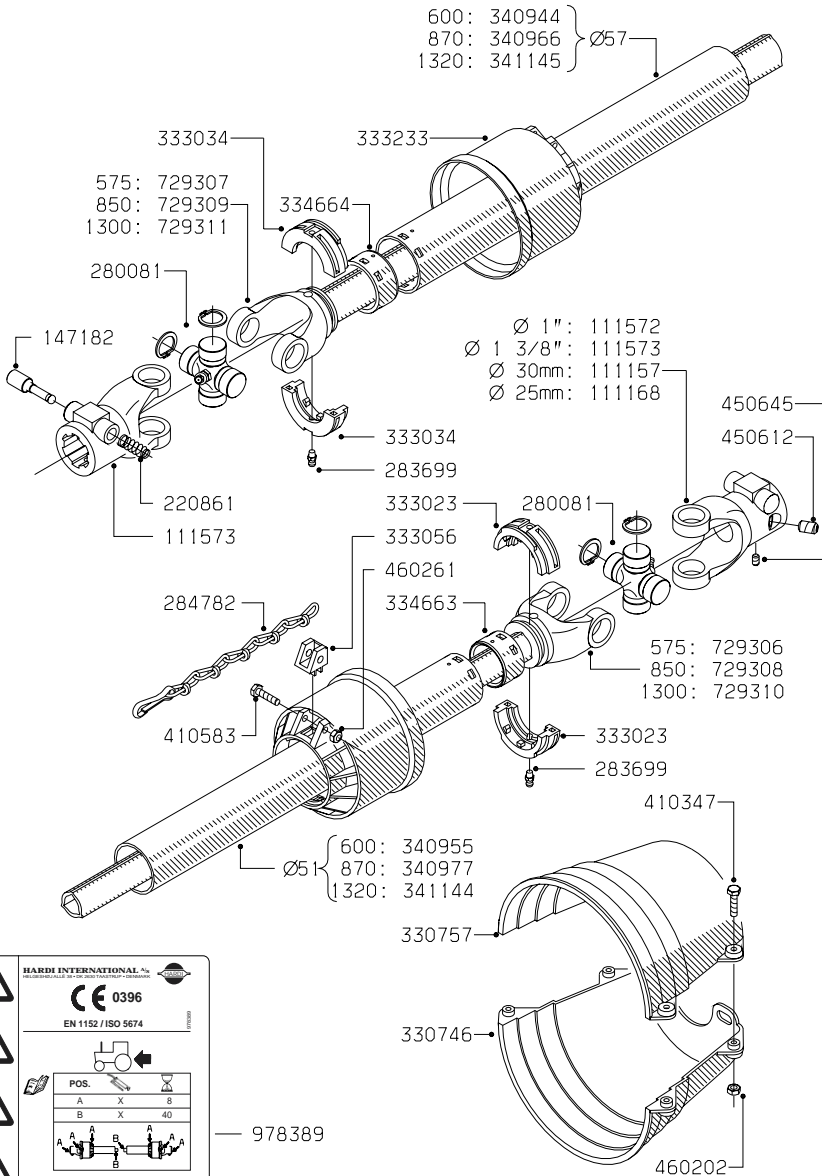

HARDI INTERNATIONAL

0396

EN 1152 / ISO 5674

POS.

A	X	18
B	X	40

rpm	kW	Nm
540	12	210
1000	18	172

978389

Shaft (94)

K604

