

## Content

EC Declaration of Conformity .....	2
Operator safety .....	3
Lifting points .....	4
Description .....	5
Function diagram .....	6
Connecting the sprayer .....	7
Drawbar .....	7
Track width .....	7
Transmission shaft .....	8
Hydraulic connections .....	10
Operating instructions .....	11
Before starting .....	11
For diaphragm pump .....	11
For piston pumps .....	11
Adjustment of controls .....	12
LP tank drain .....	19
TP tank drain valve .....	19
Operation and adjustment of S4, S6 and CANNON .....	19
Engaging and disengaging the fan .....	21
Maintenance .....	22
Cleaning the sprayer .....	22
Filters .....	24
Adjustment of V-belts - LP .....	24
Adjustment of V-belt - CANNON .....	25
Tank contents indicator .....	25
Lubrication .....	25
Changing of valves and diaphragms / plunger cups .....	27
Off-season storage .....	30
Operational problems .....	31
Technical specifications .....	32
Air volume .....	35
Pictorial symbols .....	36

# LP/TP

## Instruction book

674977-GB-96/2



# EC Declaration of Conformity

**Manufacturer,**

ILEMO-HARDI S.A.  
Pol. Ind. El Segre  
E 25080 Lérida  
SPAIN

**Importer,**

declare that the following product;

.....  
.....

Adhere extra shipping package labels to inside cover.

**A.** was manufactured in conformity with the provisions in the COUNCIL DIRECTIVE of 14 June 1989 on mutual approximation of the laws of the Member States on the safety of machines (89/392/EEC as amended by directives 91/368/EEC and 93/368/EEC) with special reference to Annex 1 of the Directive on essential safety and health requirements in relation to the construction and manufacture of machines.

**B.** was manufactured in conformity with the standards current at that time that implements a harmonised standard in accordance with Article 5 (2) and other relevant standards.

















Lérida 1.2.96

Enric Capdevila  
Managing Director  
ILEMO-HARDI S.A.

## Operator safety

Watch for this symbol . It means WARNING, CAUTION, NOTE. Your safety is involved so be alert!

Note the following recommended precautions and safe operating practices.

-  Read and understand this instruction book before using the equipment. It is equally important that other operators of this equipment read and understand this book.
-  Local law may demand that the operator be certified to use spray equipment. Adhere to the law.
-  Pressure test with clean water prior to filling with chemicals.
-  Wear protective clothing.
-  Rinse and wash equipment after use and before servicing.
-  Depressurize equipment after use and before servicing.
-  Never service or repair the equipment whilst it is operating.
-  Disconnect electrical power before servicing.
-  Always replace all safety devices or shields immediately after servicing.
-  If an arc welder is used on the equipment or anything connected to the equipment, disconnect power leads before welding. Remove all inflammable or explosive material from the area.
-  Do not eat, drink or smoke whilst spraying or working with contaminated equipment.
-  Wash and change clothes after spraying.
-  Wash tools if they have become contaminated.
-  In case of poisoning, seek doctor or ambulance. Remember to identify chemicals used.
-  Keep children away from the equipment.
-  Do not attempt to enter the tank.
-  If any portion of this instruction book remains unclear after reading it, contact your HARDI dealer for further explanation before using the equipment.





We congratulate you for choosing a HARDI plant protection product. The reliability and efficiency of this product depend on your care. The first step is to carefully **read and pay attention** to this instruction book. It contains essential information for the efficient use and long life of this quality product.

As the instruction book covers all LP and TP models, please pay attention to the paragraphs dealing with precisely your model. This book is to be read in conjunction with the "Mistblowing Technique" book.

### Lifting points

When loading or unloading the sprayer from a truck or lorry with a crane, use the lifting points as shown.

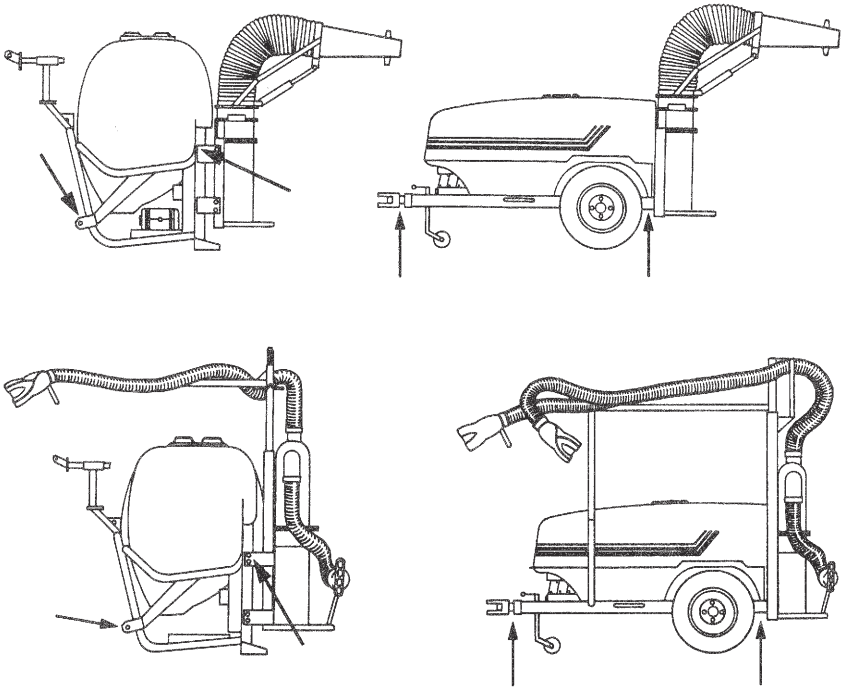

## Description

The HARDI LP lift mounted and TP trailed sprayers are designed for the application of crop protection chemicals and liquid fertilizers in greenhouses, vineyards, vegetables, berry bushes and nurseries. They feature piston or diaphragm pumps, easy to use operating units with outlets for spray gun and centrifugal blower units with gearbox.

The power is transferred from the tractor via the transmission shaft. The pump on the LP sprayers is driven with V-belts. The blower unit on the TP sprayers is driven via a through-going shaft in the pump and gearbox.

The pumps are of a robust design for agricultural usage. The simple mechanical design allows for easy maintenance. LP sprayers are supplied with a piston or diaphragm pump. TP, LP-CANNON and TP-CANNON sprayers are supplied with a piston pump.

The operating unit consists of pressure control valve, main on/off valve, pressure gauge and distribution valves. The M70/2, M/2, S/2 and BK/2 are manually operated whereas the EC/2 is electrically remote controlled.

The frame allows for easy access to the pump. Wheel axle and draw-bar position on TP sprayers can be altered.

The tank design is compact and has no sharp edges for easy cleaning. A suction filter incorporating a cut-off valve and coupling for a filling device is located at the bottom of the tank. Tank contents indicator is located on the front of the LP sprayers and on the side of the TP sprayers. Hydraulic venturi nozzles in the tank maintain a homogeneous mixture of the spray liquid.

The blower has a single 500 mm fan, single or double-sided 540 mm fan with a patented centrifugal clutch. The clutch ensures a smooth engagement and disengagement of the fan. This minimizes stress on the sprayer and tractor. The unit is fitted with a gearbox which permits disengagement of the fan for calibration, agitation whilst under transport or usage of spray guns.

The S4 pneumatic system uses low liquid pressure and high air speed to atomize the spray liquid. A ceramic metering disc is located in the delivery line to each spout outlet. Each spout head can be adjusted so the air and spray liquid is directed to the specific areas of foliage.





A wide range of application rates is possible by simply altering the pressure. The boom functions are manual on LP sprayers and hydraulic on the TP sprayers. Two additional outlets are optional.

The CANNON models are designed for single-sided spraying. The models for spraying inside greenhouses have a manually operated spout that can be rotated 180° and adjusted vertically. The models with "L" type spout head are designed for single-sided spraying up to approx. 20 m or vertical spraying to approx. 15 m. (25 m and 35 m respectively for double-sided blower) The spout can be rotated from side to side. This allows the utilization of current weather conditions so a wide spray swath can be achieved. Furthermore the spout can be angled up and down from +80° to -10°. Spray atomization is dependent on pressure and nozzle adjustment. An optional model "N" spout head is available for small row crops.

### Identification plates

An identification plate fitted on the frame and pump is to indicate model, year of production with serial number and country of origin. If ordering spare parts, inform your dealer of these so the right model and version are described.

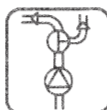

### Function diagram

1. 3-way valve
2. Suction filter
3. Coupling for filling device
4. Pump
5. Pressure agitation valve
6. Operating unit
7. Pressure gauge
8. Return to tank
9. Pressure equalization return - BK and EC only
10. Distribution valves
11. Blower unit
12. ON/OFF valves for spouts

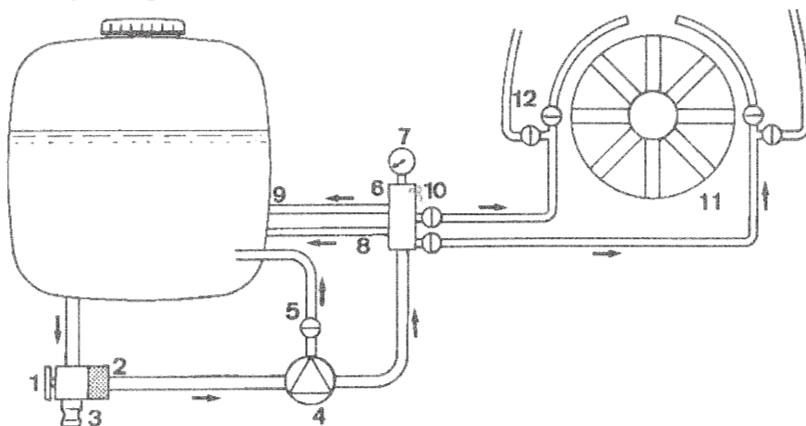

## Connecting the sprayer

### LP

The lift mounted sprayers have category I and II pivots. Two attachment points are possible.

**WARNING:** Note the weight of the sprayer. See section on Technical specifications.

Generally it is recommended to:

1. Mount the sprayer as close as possible to the tractor.
2. Add ballast to front of tractor.
3. Increase tyre pressure (see tractor instruction book).
4. Travel at slower speeds when driving with a full tank. (The tractor will have decreased braking efficiency.)
5. Be careful when filling/lifting the sprayer the first time.

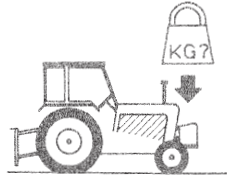

### TP

**WARNING:** The following adjustments must only be carried out when the sprayer is secured to prevent falling or rolling.

### Drawbar

The forked drawbar designed for attachment to the cross boom mounted in the tractor linkage.

The drawbar length can be regulated by loosening the counter nut and bolt

**A** under the drawbar and removing the pin **B**. After the drawbar is connected, the jack is placed in the holders above the drawbar.

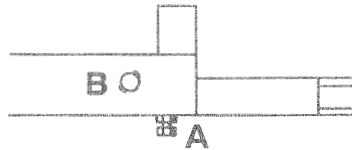

### Track width

The track width can be varied. The nuts and bolts under the axle are loosened and thereafter the hub axle can be drawn out or pushed in until required track width is obtained. See section on Technical speci-

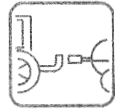
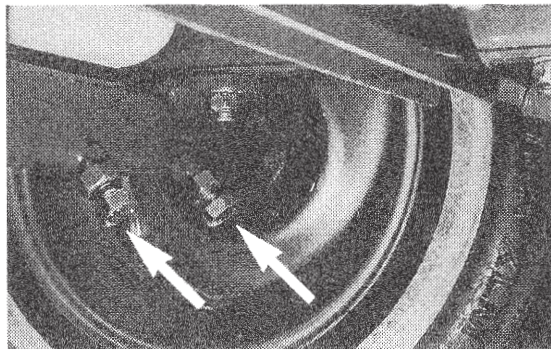

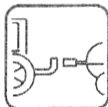

cations for minimum to maximum track width.

**CAUTION:** Secure sprayer before adjustment. Tighten bolts and nuts after adjustment.

## Transmission shaft

### Operator safety

To avoid accidents and personal injuries, note the following recommended precautions and safe operation practices.

Always STOP ENGINE before attaching the transmission shaft to tractor P.T.O. - most tractor P.T.O. shafts can be rotated by hand to facilitate spline alignment, when engine is stopped.

When attaching the shaft, make sure that the snap lock is FULLY ENGAGED - push and pull shaft until it locks.



**WARNING:** ROTATING TRANSMISSION SHAFTS WITHOUT PROTECTION GUARDS ARE FATAL

Always keep protection guards and chains intact and make sure that it covers all rotating parts, including cross journals at each end of the shaft. Do not use without protection guard.

Do not touch or stand on the transmission shaft when it is rotating - safety distance: 1.5 metre.

Prevent protection guards from rotating by attaching the chains allowing sufficient slack for turns.

Make sure that protection guards around tractor P.T.O. and implement shaft is intact.

Always STOP ENGINE and remove the ignition key before carrying out maintenance or repairs to the transmission shaft or implement.

### Installation of transmission shaft

Initial installation of the shaft is done as follows:

1. Attach sprayer to tractor and set sprayer in the position with **shortest** distance between the tractor and sprayer pump P.T.O. shafts.
2. Stop engine and remove ignition key.
3. If transmission shaft must be shortened, the shaft is pulled apart. Fit the two shaft parts at tractor and sprayer pump and measure how much it is necessary to shorten the shaft. Mark the protection guards.



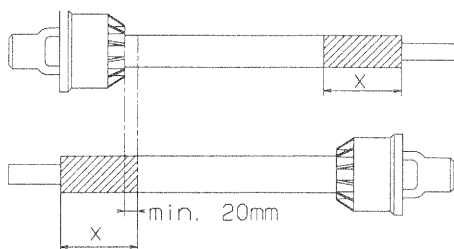

**NOTE:** The telescoping profiles must overlap at least by  $\frac{1}{3}$  of their length while in use.

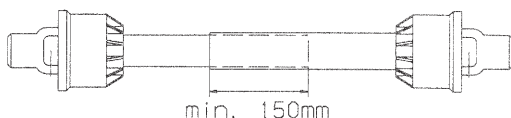

4. The two parts are shortened equally. Use a saw, and file the profiles afterwards to remove burrs.
5. Grease the profiles, and assemble male and female parts again.

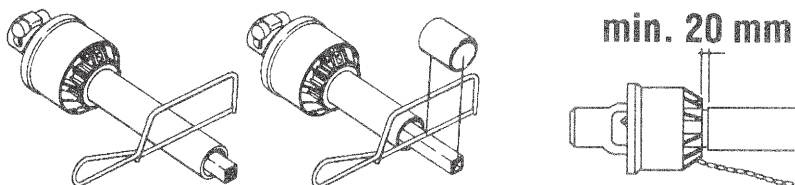

6. Fit the shaft to tractor and sprayer pump.

**NOTE:** Female part towards tractor. Fit the chains to prevent the protection guards to rotate with the shaft.

7. To ensure long life of the transmission shaft, try to avoid working angles greater than  $15^\circ$ .

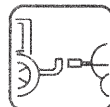
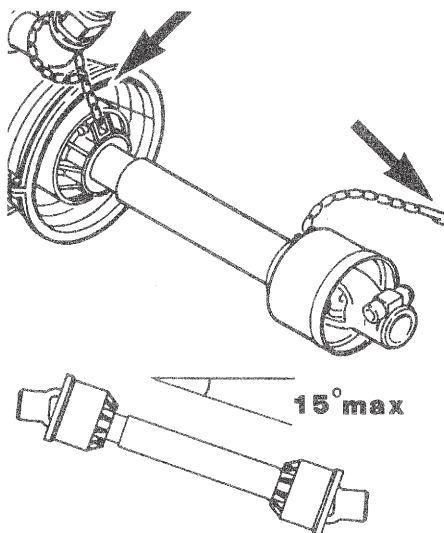

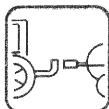

### For TP sprayers

- adjust the drawbar so the connection point is midway along the transmission shaft.
- disengage P.T.O. if turning at angles greater than 35°.
- use an articulated drawbar and transmission shaft with CV joint for narrow rowed plantations.

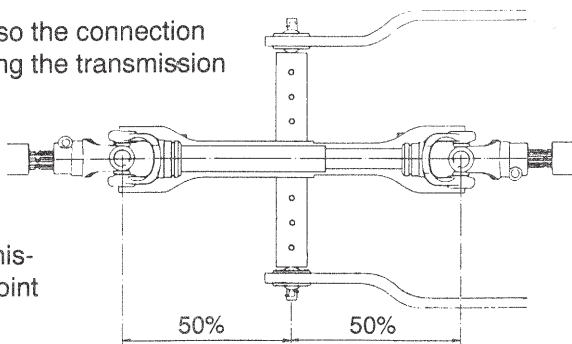

### Rear lights (if fitted)

Connect plug for rear lights to tractors 7-poled socket, loosen the lights assembly knob, extend assembly and tighten the knob. Check that rear lights, stop lights and turning indicators function properly.

**NOTE:** Remember to retract lights assembly when not needed.



### EC control box (if fitted)

Power requirement is 12 V DC. Note polarity!

Brown pos. (+), Blue neg. (-).



The control box is fitted in the tractor cabin at a convenient place. The wires must have a cross-sectional area of at least 1.0 mm<sup>2</sup> to ensure sufficient power supply.

Use the HARDI Electric distribution box (Ref. no. 817925) if the tractor has a doubtful power supply.

### Hydraulic connections

For TP; a single and a double-acting outlet is required.

For LP-CANNON and TP-CANNON; two double-acting outlets are required.

**NOTE:** The system requires an oil capacity of approx. 2 litres and a min. pressure of 130 bar. Maximum pressure must not exceed 180 bar.



### Roadworthyness

When driving on public roads and other areas where the highway code applies, or areas where there are special rules and regulations for marking and lights on implements, you should observe these and equip implements accordingly.

# Operating instructions



## Before starting

Check that suction filter 1 is clean.

Check that arrow on the 3-way valve 2 is set correctly.

Check that the pressure agitation valve is turned on. (If the valve is fitted it is located near the pump). It only needs to be turned off if the products used have a tendency to create foam or if there is difficulty in completely emptying the spray tank.

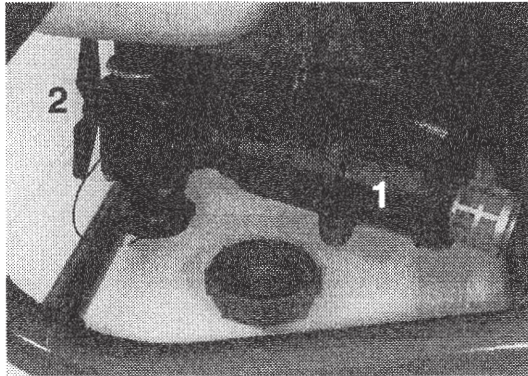

## For diaphragm pump

The air pressure in the pulsation damper is factory preset at 2 bar to cover spray working pressures between 3 and 15 bar. When using spray pressures outside this range, the air pressure should be adjusted as shown in the diagram. The diagram is also embossed on the damper.

<b>bar</b>	<b>bar</b>
<b>1.5 - 3</b>	<b>0 - 1</b>
<b>3 - 15</b>	<b>1 - 3</b>

## For piston pumps

Check oil level of pump. Level must be between minimum and maximum mark on dipstick 1. P3X pump also has an external oil level indicator 2.

Piston pumps need to be run in. To prolong the life of the pump do not operate the pump at maximum pressure for the first 40 hours.

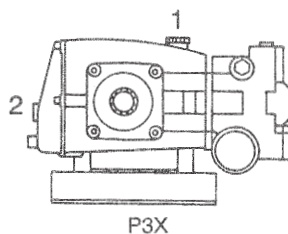
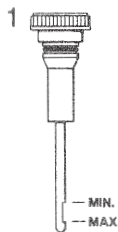
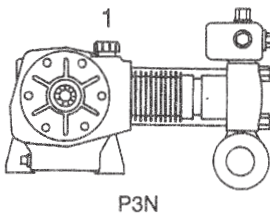



Pump	0 - 40 h	40 h +
P3X	40 bar	55 bar
P3N	45 bar	60 bar



**WARNING:** Do NOT operate pump over 540 r/min. Do not run pump dry for more than 60 seconds.

### Adjustment of controls

Please see section dealing with your operating unit. Initial adjustment and calibration is done with clean water. See also "Mistblowing Technique" book.



**NOTE:** To ensure long bearing life, the tractor P.T.O. must not exceed 540 r/min.

### Pressure recommendations

When using the pneumatic system, the recommended spraying pressure is between 1 to 4 bar.

When using the CANNON system, the recommended spraying pressure is between 7 to 30 bar.

When using spray guns, the recommended spraying pressure is between 10 to 30 bar.

### M70/2 operating unit

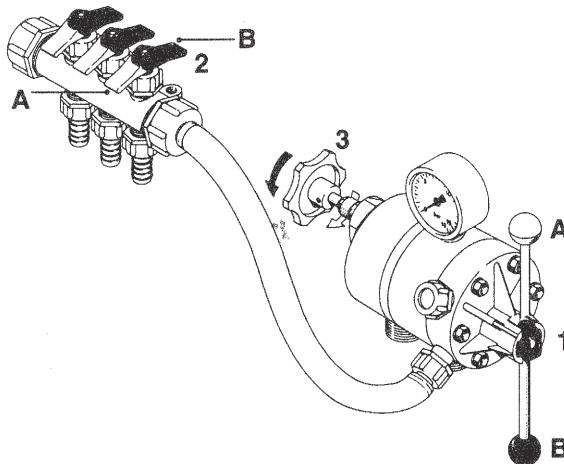

1. Turn main ON/OFF handle **1** to ON position **A**.
2. Set hand levers on the distribution valve **2** to ON position **A**.
3. Put the tractor in neutral and set the P.T.O. revolutions to 540 r/min.
4. From a given forward speed in a gear and the nozzles chosen, the desired pressure on the pressure gauge is set by means of the pressure adjustment handle **3**.

**NOTE:** Maximum pressure is 15 bar. Do not operate over 15 bar.

### Operating the unit whilst spraying

To stop the liquid flow on both sides of the blower, turn the handle **1** to OFF position **B**. This takes the pressure off the pump. The liquid will then return to the tank via the return system. If you want to spray on one side only, set handle **2** to OFF position **B** on the side you want to close off. Note that the pressure will rise and readjustment will be necessary.

### M/2 operating unit

1. Push handle **1** to ON position **B**.
2. Turn pressure adjustment knob **3** to minimum setting (anti-clockwise).
3. The two handles **2** are set at ON position **A**.
4. Put the tractor in neutral and set the P.T.O. revolutions to 540 r/min.
5. From a given forward speed in a gear and the nozzles chosen, the desired pressure on the pressure gauge is set by means of the pressure adjustment knob **3**.

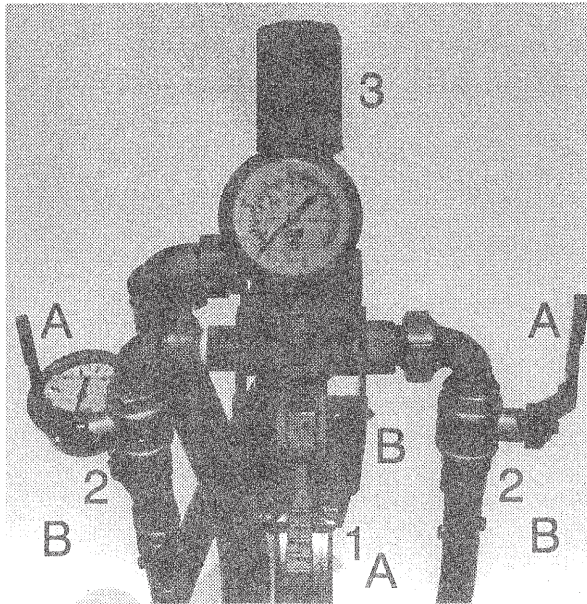

pressure on the pressure gauge is set by means of the pressure adjustment knob **3**.

**WARNING:** When using the pneumatic system, do not spray over 4 bar as this will damage the spout line.





**NOTE:** Maximum pump pressure is 60 bar. Do not operate over 60 bar.

### Operating the unit whilst spraying<sup>†</sup>

To stop the liquid flow on both sides of the blower, set handles 1 and 2 to OFF position **B**. If you only want to spray on one side only, turn handle 2 to OFF position **B** on the side you want to close off. Note that the pressure will rise and readjustment will be necessary.

### S/2 operating unit

1. Turn handle 1 to neutral position **A**.  
This permits pressure adjustment before spraying.
2. Put the tractor in neutral and set the P.T.O. revolutions to 540 r/min.
3. From a given forward speed in a gear and the nozzles chosen, the desired pressure on the pressure gauge is set by means of the pressure adjustment handle 2. Fine adjustment may be necessary when nozzles are turned on.

**NOTE:** Maximum pressure is 60 bar.  
Do not operate over 60 bar.

### Operating the unit whilst spraying

To turn liquid flow on to both sides turn handle 1 to ON position **B**. If you want to spray on one side only, turn handle 1 to position **C** on the side you want to open. To stop the liquid flow to both sides of the blower, turn handle 1 to position **D**. Note that the pressure will rise and readjustment will be necessary.

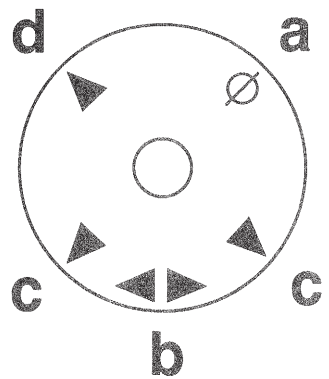
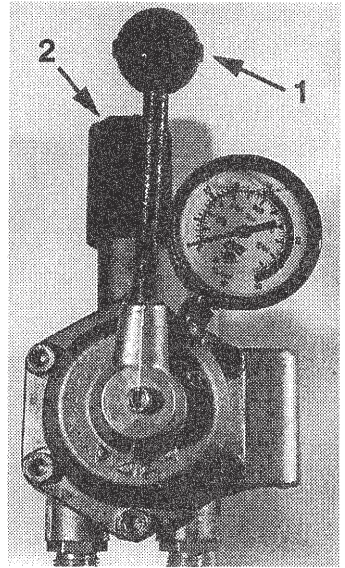

## BK operating unit

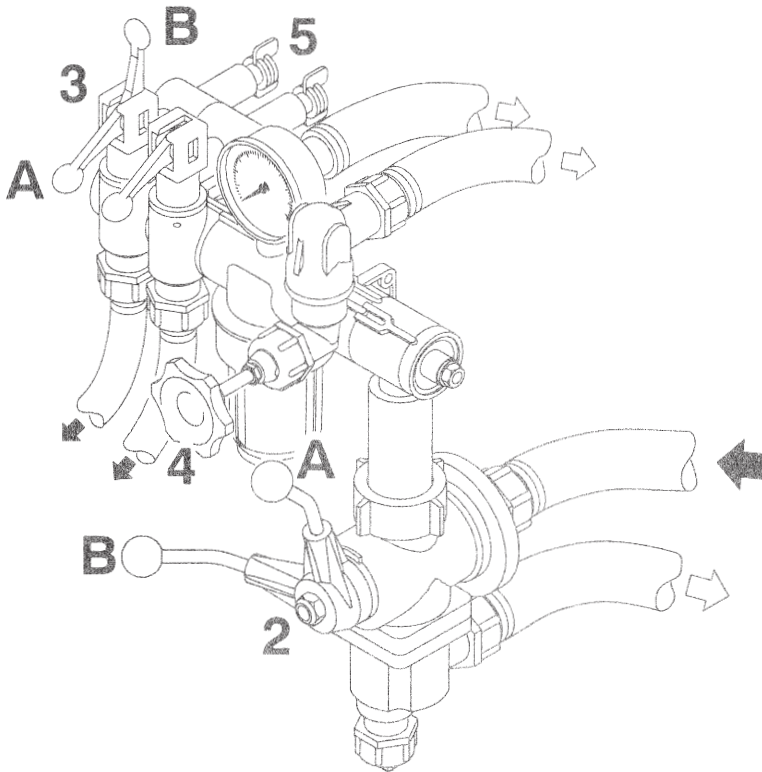

1. Turn main ON/OFF handle 1 to ON position A.
2. Set levers 2 on the distribution valve to ON position A.
3. Turn the pressure adjustment valve 3 anti-clockwise to minimum pressure setting.
4. Put the tractor in neutral and set the P.T.O. revolutions to 540 r/min.
5. From a given forward speed in a gear and the nozzles chosen, the desired pressure on the pressure gauge is set by means of the pressure adjustment handle 3.

**NOTE:** Maximum pressure is 15 bar. Do not operate over 15 bar.

### ADJUSTMENT OF PRESSURE EQUALIZATION

6. Note the pressure and place the first lever 2 on the distribution valve to OFF position B.
7. Turn the corresponding adjusting screw 4 until the pressure gauge again shows the same pressure.





9. Adjust the other section of the distribution valve in the same way.

**NOTE:** Hereafter adjustment of pressure equalization will only be needed if you change to nozzles of other capacities.

### Operating the unit whilst spraying

To stop the liquid flow to both sides of the blower, turn the handle 1 to position B. This takes the pressure from the pump. The liquid will then return to the tank via the return system. If you want to spray on one side only, set lever 2 of the distribution valve to OFF position B for the section to be closed. The pressure equalization device ensures that the pressure does not rise in the section which remains open.

### EC/2 operating unit

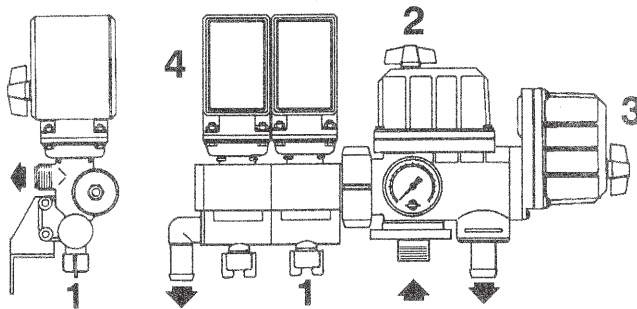

1. Adjust screw for pressure equalization
2. Main ON/OFF valve
3. Pressure control valve
4. Distribution valve

### EC control box

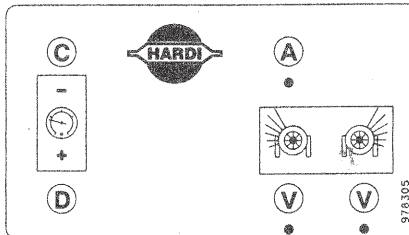

- A. Operating switch for ON/OFF valve
- V. Operating switch for distribution valves
- C. Pressure regulation switch (to lower)
- D. Pressure regulation switch (to raise)



1. ON/OFF switch **A** is set towards green (ON).
2. The distribution valves switches **V** are set towards green (ON).
3. Pressure regulation switch **C** is activated until knob **3**, stops rotating (minimum pressure).
4. Put the tractor in neutral and set the P.T.O. revolutions to 540 r/min.
5. From a given forward speed in a gear and the nozzles chosen, the desired pressure on the pressure gauge is set by means of the pressure regulation switch **D**.

**NOTE:** Maximum pressure is 25 bar. Do not operate over 25 bar.

#### ADJUSTMENT OF PRESSURE EQUALIZATION

6. Close the first distribution valve switch **V**.
7. Turn the adjusting screw **1** until the pressure gauge again shows the same pressure.
8. Adjust the other section in the same manner.

**NOTE:** Hereafter adjustment of pressure equalization will only be needed if you change to nozzles of other capacities.

#### Operating the unit whilst spraying

To stop the liquid flow to both sides of the blower, switch ON/OFF **A** to OFF position. This returns the pump output to the tank through the return system.

If you want to spray on one side only, switch the relevant distribution valve **V** to OFF position for the section to be closed. The pressure equalization ensures that the pressure does not rise in the section which remains open.

In case of power failure it is still possible to activate all functions of the operating unit. To operate manually, first disconnect the multiplug and then turn the relevant knob.

When the sprayer is put aside, the control box and the multiplug must be protected against moisture and dirt. A plastic bag may be used to protect the multiplug.



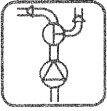

## Self-Cleaning Filter (if fitted)

### Function diagram

1. From pump
2. To safety valve (operating pressure is 25 bar)
3. Double filter screen
4. Guide cone
5. To operating unit
6. 3, 4, 5 or 6 mm restrictor
7. Return to tank
8. Nut

### Choice of restrictor

It is important to have a large flow through the filter. This is achieved by choosing the restrictor size in relation to the liquid consumption of the sprayer.

4 restrictors are supplied. Use the green one (largest orifice **A**) first.

The hose **N** is unscrewed at the Self-Cleaning Filter, the restrictor is put in the hose and the hose is mounted again.

If the required working pressure cannot be obtained, the restrictor is too large. Choose a smaller restrictor.

Start with the black one, then the white and finally the red one.

When cleaning the filter remove hose **N** and the hose at the safety valve, and check there are no residues.

Standard filter size is 80 mesh. Sizes of 50 and 100 mesh are available and can be changed by opening the filter top. Check the O-rings before reassembling the filter and replace if damaged.

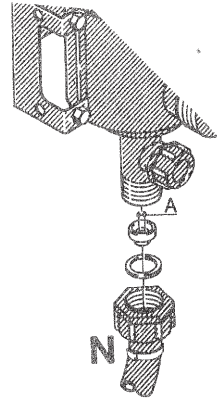
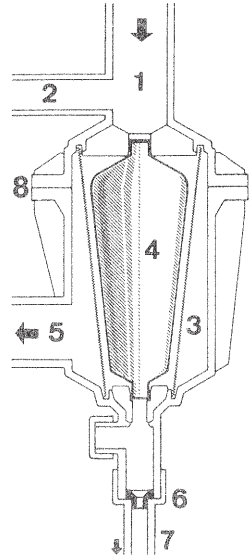

## LP tank drain

The tank can be drained via the suction filter assembly.

1. Turn handle **A** so arrow points towards the quick coupler.
2. Remove the filter cap and filter **B**.
3. Turn handle **A** towards tank suction hose to drain.

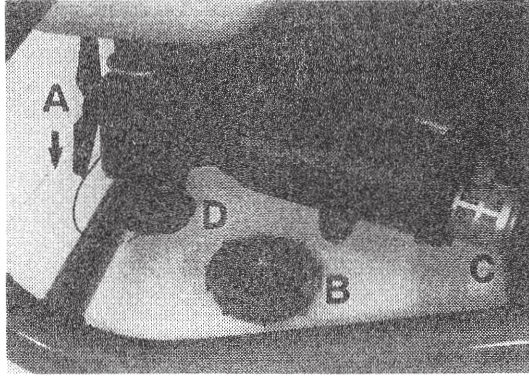

## TP tank drain valve

Pull the red handle on the top of the tank to open the drain valve. The valve is spring-loaded, but can be kept open by pulling the string out and upwards in the V-shaped slit. To release, pull the string downward and the valve will close automatically.

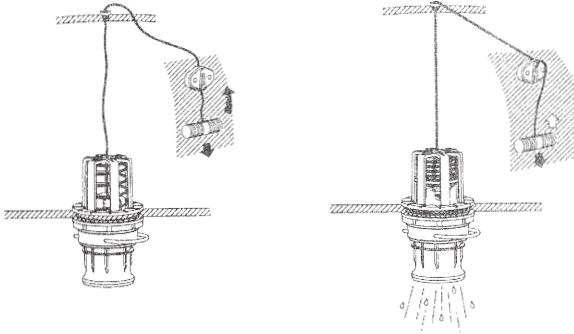

## Operation and adjustment of S4, S6 and CANNON

**CAUTION:** Testing of the hydraulics should be done cautiously. There may be air in the system and this may cause violent movements of the boom. Take care that no persons or objects are hurt or damaged in the process of testing.



It is recommended to do the adjustments with the sprayer in the plantation/field to be sprayed. Use clean water when adjusting.



### S4/S6 boom

1. The LP S4 boom is unfolded manually. The TP S4 or S6 boom is first raised clear of the transport brackets via the single-acting hydraulic and then unfolded via the double-acting hydraulics.

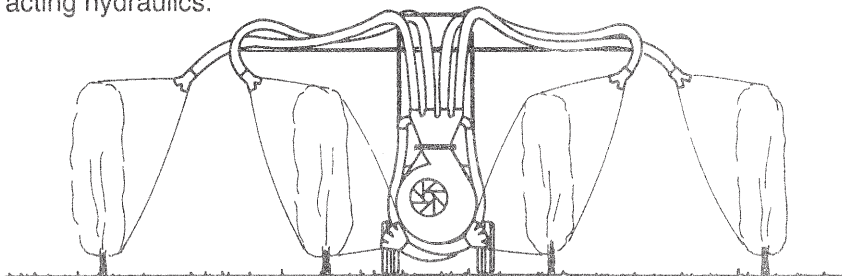
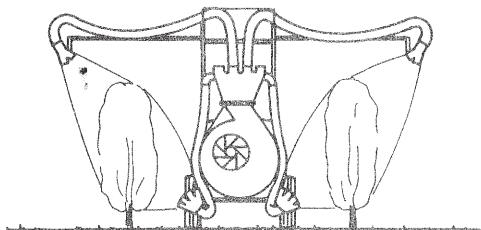

2. Adjust the boom height and spouts so that they point toward the foliage. For LP S4, cautiously loosen counter nuts **A** and bolts **B** on both sides. Boom can now be raised or lowered. Retighten bolts and counter nuts.

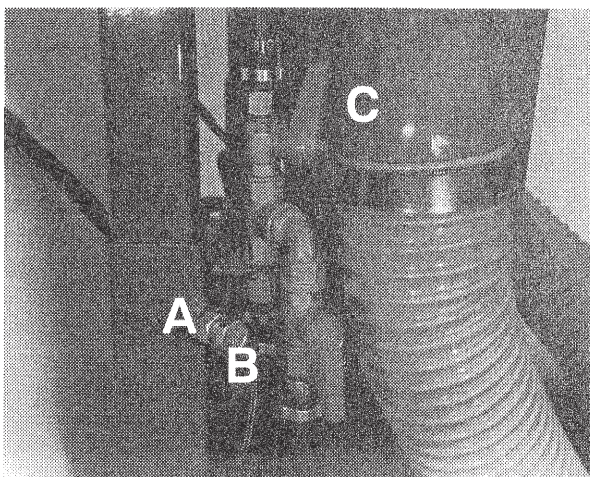

The S6 boom is designed for

spraying larger vines or vines in wider rows more effectively.

3. Engage the fan, set the P.T.O. revolutions to 540 r/min and check the spout positions by spraying. Liquid flow to the spouts can individually be turned off. Valves **C** are located just in front of the blower manifold.

4. It is possible to alter the liquid output by altering the orientation or changing the metering disc (nozzle type 1099). The disc is located at **A**. At calibration, the hose can be removed from the "Tee" piece to check output. See also "Mistblowing Technique" book.

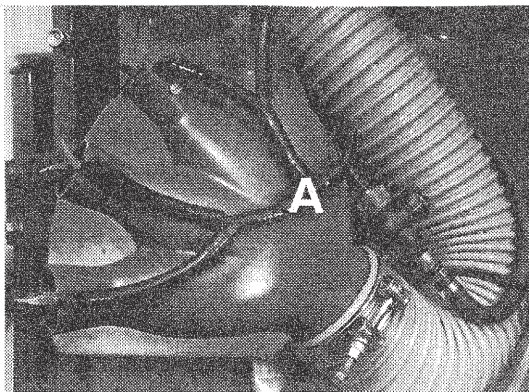

## CANNON

1. If spraying horizontally, plan the spray job so that any breeze or wind comes from behind the spraying direction. The spout for the P500 greenhouse models is operated manually. The spout for the P540 and P540D models can be angled and turned to either side via the double-acting tractor hydraulics.
2. Engage the fan, set the P.T.O. revolutions to 540 r/min. and check the spout position by spraying. The spout may be equipped with an adjustable slot under the spout. It may also need to be adjusted.
3. For P500 models, nozzles of different outputs can be chosen to alter liquid output. For P540 and P540D models, it is possible to alter the liquid output by adjusting the nozzles. This is done by turning the nozzle cap assembly.

## Engaging and disengaging the fan

Calibration, spraying with guns or agitation under transport only needs the operation of the pump and it is therefore practical to disengage the fan.

The gear box located at the rear of the tank. The handle is set at position **O** to disengage the fan and position **I** to engage the fan.

**IMPORTANT:** P.T.O. must be disengaged and both pump and fan must be stationary when engaging/disengaging the fan.

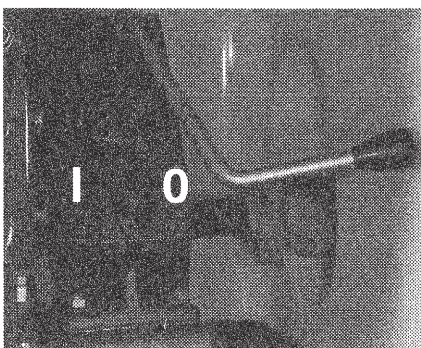

**Calibration** - see "Mistblowing Technique" book.

**Air volume and air speed** - see section on Technical specifications.



## Maintenance

In order to derive full benefit from the sprayer for many years to come, these few but simple points should be noted.



## Cleaning the sprayer

### Guidelines

Read the whole label of the chemical. Take note of any particular instructions regarding recommended protective clothing, deactivating agents, etc. Read the detergent and deactivating agent labels. If cleaning procedures are given, follow them closely.

Be familiar with local legislation regarding disposal of pesticides washings, mandatory decontamination methods, etc. Contact the appropriate body, eg. Dept of Agriculture.

Pesticide washings can usually be sprayed out on a soakaway. This is an area of ground that is not used for cropping. You must avoid seepage or run-off of residues into streams, water courses, ditches, wells, springs, etc. The washings from the cleaning area must not enter sewers. Drainage must lead to a soakaway.

Cleaning starts with the calibration, as a well calibrated sprayer will ensure the minimal amount of remaining spray liquid. It is good practice to clean the sprayer immediately after use thereby rendering the sprayer safe and ready for the next pesticide application. This also prolongs the life of the components.

It is sometimes necessary to leave spray liquid in the tank for short periods, eg. overnight, or until the weather becomes suitable for spraying again. Unauthorized persons and animals must not have access to the sprayer under these circumstances.

If the product applied is corrosive, it is recommended to coat all metal parts of the sprayer before and after use with a suitable rust inhibitor.

Remember: Clean sprayers are safe sprayers.  
Clean sprayers are ready for action.  
Clean sprayers can not be damaged by pesticides and their solvents.

## Cleaning

1. Dilute remaining spray liquid in the tank with at least 10 parts water and spray the liquid out in the orchard you have just sprayed.  
**NOTE:** It is advisable to increase the forward speed (double if possible) and reduce the pressure.
2. Select and use the appropriate protective clothing. Select detergent suitable for cleaning and suitable deactivating agents if necessary.
3. Rinse and clean sprayer and tractor externally. Use detergent if necessary.
4. Remove suction filter and clean. Be careful not to damage the mesh. Reassemble the filter housing without the filter. Replace filter when the sprayer is completely clean.
5. With the pump running, rinse the inside of the tank. Remember the tank roof. Rinse and operate all components and any equipment that has been in contact with the chemical.  
Before opening the distribution valves and spraying the liquid out, decide whether this should be done in the orchard again or on the soakaway.
6. After spraying the liquid out, stop the pump and fill at least 1/5 of the tank with clean water. Note that some chemicals require the tank to be completely filled. Add appropriate detergent and/or deactivating agent, eg. Washing soda or Triple ammonia.  
**NOTE:** If a cleaning procedure is given on the chemical label, follow it closely.
7. Start the pump and operate all controls enabling the liquid to come in contact with all the components. Leave the distribution valves until last. Some detergents and deactivating agents work best if left in the tank for a short period. Check the label.
8. Drain the tank and let pump run dry. Rinse inside of tank, again letting the pump run dry. Remember that piston pumps must not run dry for more than a minute.
9. Stop the pump. If the pesticides used have a tendency to block nozzles and filters, remove and clean them now.
10. Replace all the filters and nozzles and store the sprayer. If, from previous experiences, it is noted that the solvents in the pesticide are particularly aggressive, store the sprayer with the tank lid open.  
**NOTE:** If the sprayer is cleaned with a high pressure cleaner we recommend lubrication of the entire machine.





## Filters

Clean filters ensure:

- Sprayer components such as valves, diaphragms and operating unit are not hindered or damaged during operation.
- Nozzle blockages do not occur whilst spraying.
- Long life of pump. A blocked suction filter will result in pump cavitation.

The main filter protecting sprayer components is the suction filter. Check it daily when spraying. Ensure the O-ring on filter housing is in good condition and lubricated.

### **BK Pressure filter / In-Line Filters (if fitted)**

The BK operating unit has a built-in pressure filter. Unscrew the filter bowl to inspect and clean the filter.

The sprayer may be equipped with In-Line Filters. Unscrew the filter bowl to inspect and clean the filter.

## Adjustment of V-belts - LP

Correct belt tension is important for efficient power transfer. Under tensioned belts will slip and overheat reducing belt life whilst over tensioned belts will reduce belt and bearing life.

Check the V-belts regularly within the first 24 working hours as they need to be run in. Tighten if necessary.

Thereafter check every 40 hours.

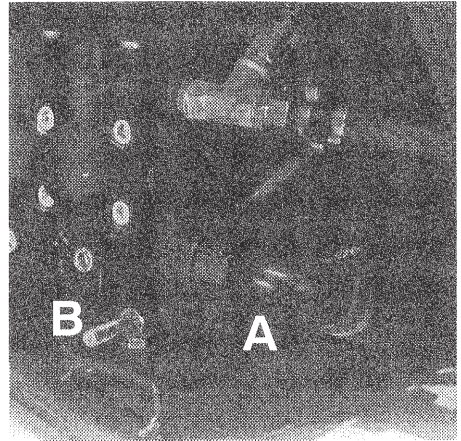

The pump drive V-belts are adjusted by loosening the bolts **A** at the base of the pump, loosening counter nut and adjusting bolt **B** at the foot of the pump.

Adjust tension so that at midway between pulleys, a force of 1 kg should deflect the V-belt 2 to 3 mm. Do not over-tighten the V-belts.



## Adjustment of V-belt - CANNON

If the V-belt begins to slip, the tension must be increased. Loosen bolt **C** below V-belt pulley. Adjust by means of nut **D**.

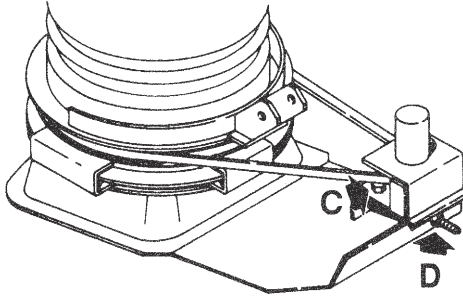

**NOTE:** Tighten all counter nuts and replace guards after adjustment.

## Tank contents indicator

Depending on products used, it can become difficult to see the red sphere inside the level indicator tube. Note that the tube can be replaced when necessary.

## Lubrication

Recommended lubrication is shown as follows. Use ball bearing grease (lithium grease No. 2).

**NOTE:** If the sprayer is cleaned with a high pressure cleaner or it has been used to spray fertilizer, we recommend lubrication of the entire machine.

## Diaphragm pump

Grease every 40th working hour.

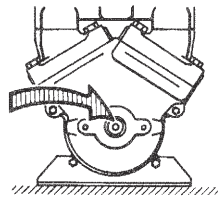

## Piston pump

Check oil daily when spraying. Level must be visible between the minimum and maximum mark of the indicator.

The pump is filled with oil from the factory. Change the oil after the first 50 hours of work. Thereafter as described in following table or once a year.

**A** = Drain plug **B** = Level indicator **C** = Filling hole

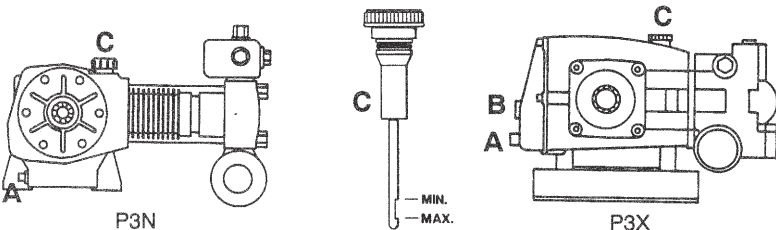



### Transmission shaft

Lubricate the cross journals and bearings with ball bearing grease **A** every 8th working hour and tubes and pins **B** every 20th working hour.

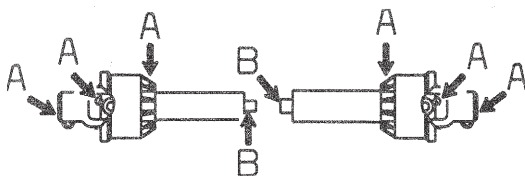

### Gear box

The gear box is filled with oil from the factory. Regularly check oil level. The oil level must come to the indicator glass.

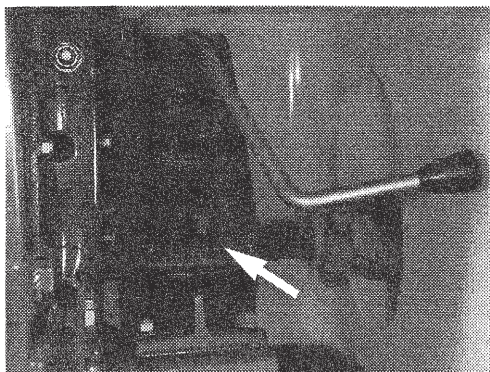

### TP transmission shaft

This includes the power transmission shaft and bearings connecting the pump and the blower unit.

### TP drawbar and wheel axles

The swivel of the drawbar and axles should be greased at least once a year.

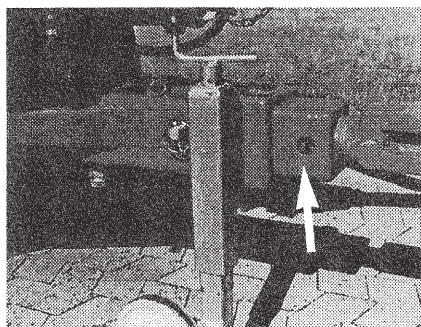

	Oil cap. litre	Oil type SAE	Initial change hours	There after hours
Pump P3X	1.5	20/40 HD	50	150
Pump P3N	2.5	20/40 HD	50	150
LP gearbox	0.3	20/40 HD	50	150
TP gearbox	1.3	20/40 HD	50	150

## Changing of valves and diaphragms / plunger cups

### Diaphragm pump

#### Valves

Remove valve cover (1). Before changing the valves (2) note the orientation of the valves so that they are replaced correctly. It is recommended to use new gaskets (3) when changing or checking the valves.

#### Diaphragms

Remove the diaphragm cover (4) after having dismantled the valve cover. The diaphragm (5) may then be changed. If fluids have reached the crankcase, re-grease the pump thoroughly. Check also the drain hole at the bottom of the pump is not blocked.

Reassemble pump with the following torque settings.

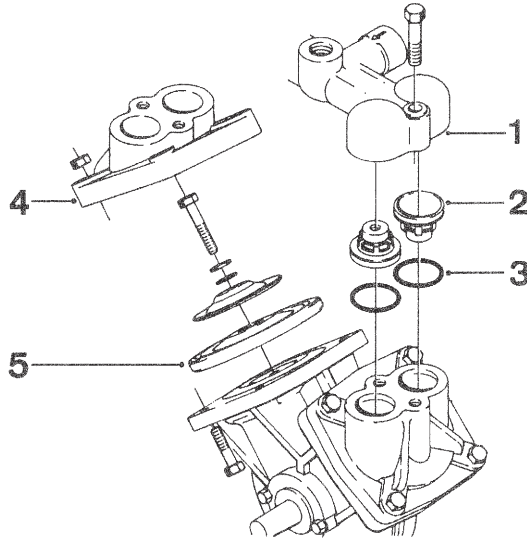

Pump Model	Valve cover Nm	Diaphragm cover Nm	Diaphragm bolt Nm
600	45	50	25

1 Nm = 0.74 ft-lb



## Piston pumps P3X/P3N Valves

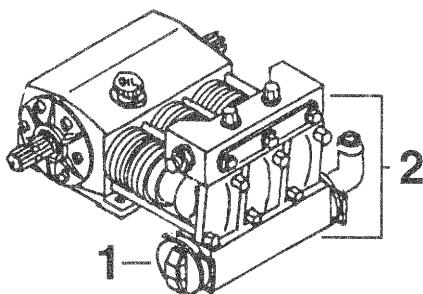
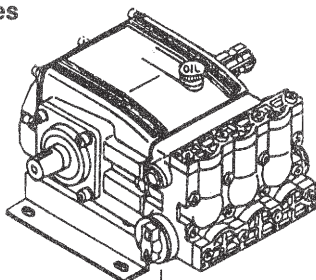

1. Remove suction cover 1 so that the liquid is drained from the pump.
2. Remove valve chamber 2. Note orientation of the valves. It is recommended to use new O-rings 3 when checking or changing the valves.

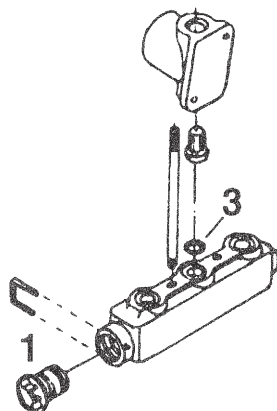
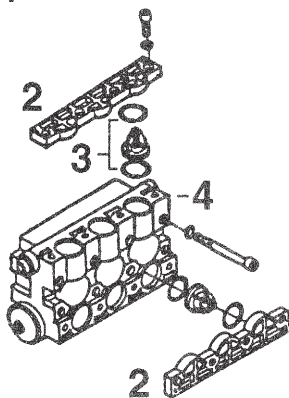

**NOTE:** For valves with ball seat, the valve seat can be rotated.

### Plunger cups

1. The valve chamber must be removed first (P3N only).
2. Remove cylinder head 4.
3. Use spanner to loosen nut 5.
4. Cylinder can now be removed so the cups 6 can be removed.
5. At reassembly, grease cups and inside of cylinder.
6. Assemble cup 6, rubber expander 7, washer 8 and self-locking nut 5.
7. Tighten nut (30 Nm). Do **NOT** over tighten. If it is too tight, the cups will wear rapidly. If it is too loose, liquid will leak from the drain port of the cylinder.
8. Finish the assembly and run the pump for 1/2 hour. If liquid leaks from the drain ports, it is necessary to tighten nut 5. Only tighten 1/4 of a turn. This may also be necessary if the cups have dried out after off-season storage.

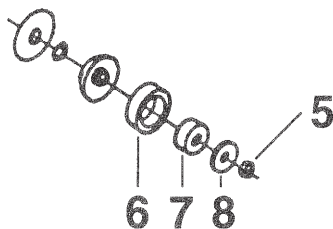

## Off-season storage

When the spraying season is over you should devote some extra time to the sprayer, before it is stored.

### Anti-freeze precautions

If the sprayer is not stored in a frost-proof place you should take the following precautions: Put at least 10 litres of 33% anti-freeze mixture in the tank and let the pump run a few minutes so that the entire system including spray lines are filled. Remove the glycerine filled pressure gauge and store it frost free in vertical position.

The anti-freeze solution also hinders the O-rings, plunger cups and gaskets from drying out.

### Hoses

Check that none of the hoses are pinched or have sharp bends. A leaky hose causes annoying delays in the middle of spraying. Check all the hoses and replace if there is any doubt of their durability.

### Paint

Some chemicals are very corrosive. It is therefore advisable to remove rust, if any, and touch up the paint.

### M70/2, M/2 and S/2 operating unit

Ensure the pressure regulating valve is relieved or released. This relieves the pressure on the spring and operating problems are avoided when starting up.

### Tank

Ensure that all chemical residues are removed from the tank and rest of the sprayer.

### Transmission shaft

It is important that the push pins are clean and well lubricated, to ensure safe function.

Every 40 hours:

Inspection of protection guards, function and condition. Replace possible damaged parts.

Every 1000 hours:

Check condition of protection guards and replace nylon bearings.

Check general condition of cross journals and push-pin/quick release - replace if necessary.





## Operational problems

In cases where breakdowns have occurred the same factors always seem to come into play:

- Minor leaks on the suction side of the pump will reduce the pump capacity or stop the suction completely.
- A clogged suction filter will hinder or prevent suction so that the pump does not operate satisfactorily.
- Clogged up pressure filters will result in increasing pressure at the pressure gauge but lower pressure at the nozzles.
- Foreign bodies stuck in the pump valves with the result that these cannot close tightly against the valve seat, reducing pump efficiency.
- Poorly reassembled pumps, especially valve covers will allow the pump to suck air resulting in reduced or no capacity.
- Worn plunger cups will reduce the pump capacity. It will be necessary to replace them when working pressure cannot be reached or liquid leaks from the cylinder ports.
- Reduced working pressure may also be due to insufficient spring strength or a worn valve cone on the pressure control unit.
- Loose or partially loose V-belts may result in lower revolutions per minute on the blower and overheating of the V-belts.
- Electrical components that are contaminated with dirt result in poor connections.

### Therefore ALWAYS check:

1. Suction, pressure and nozzle filters are clean.
2. Hoses for leaks and cracks, paying particular attention to suction hoses.
3. Gaskets and O-rings are present and in good condition.
4. Pressure gauge is in good working order. Correct dosage depends on it.
5. Operating unit functions properly. Use clean water to check.
6. Electrical components are maintained clean.

## Trouble shooting

Fault	Possible cause	Control / remedy
No liquid flow from pump	Suction obstructed.	Check filters. Suction cut-off open.
	Air leak on suction.	Missing O-rings. Defect hoses.
	Valves obstructed or worn.	Replace.
No pressure	Worn control unit.	Check spring strength.
	Valves obstructed or worn. Worn plungers.	Replace.
Fluctuating pressure	Valves obstructed or worn.	Replace.
	Air leak on suction.	Missing O-rings. Defect hoses.
	Suction obstructed.	Replace.
Pump noisy	Worn bearings. Valves worn.	Replace.
	Air leak on suction.	Missing O-rings. Defect hoses.
Water in oil	Cylinder seals defect. Piston seals worn.	Replace.
	High air humidity.	Change oil twice as often.
Liquid leaks at cylinder seals	Worn plungers. Cylinder barrel worn.	Replace.



### Emergency operation of EC

In case of power failure it is possible to activate the unit manually. First disconnect the multiplug from the control box. The knobs can be turned manually. The problem may be due to a blown fuse. The fuses are in the control box and are marked according to functions.

(7 and 8 are spare fuses).

Fuse type T 1.25 mA  
HARDI ref. no. 261589

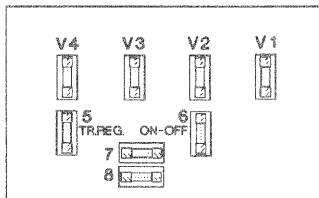
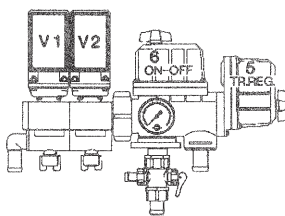

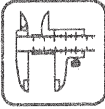

## Technical specifications

### Pump power consumption and capacity

600/70	350		400		r/min 500		540				
	bar	l/min	kW	l/min	kW	l/min	kW	l/min	kW	l/min	kW
0	20,5	0,15	30,0	0,22	39,0	0,29	42,0	0,30			
5	16,5	0,29	22,5	0,45	28,5	0,52	30,5	0,59			
10	16,5	0,45	22,0	0,59	27,5	0,82	30,0	0,89			
15	16,0		21,0		26,5		28,0				
Rotation per min.	r/min	Capacity				l/min	Suction height			0,0 m	
Power consumption	kW	Max. pressure				15bar	Weight			15,6 kg	

P3X-70	350		400		r/min 500		540				
	bar	l/min	kW	l/min	kW	l/min	kW	l/min	kW	l/min	kW
0	45	0.01	52	0.01	65	0.01	70	0.01			
10	45	0.79	52	0.90	65	1.13	70	1.22			
20	45	1.56	52	1.78	65	2.22	70	2.40			
30	45	2.33	52	2.67	65	3.34	70	3.60			
40	45	3.11	52	3.56	65	4.45	70	4.80			
50	45	3.89	52	4.45	65	5.56	70	6.01			
55	45	4.28	52	4.90	65	6.12	70	6.61			
Rotation per min.	r/min	Capacity				l/min	Suction height			0,0 m	
Power consumption	kW	Max. pressure				55bar	Weight			21,0 kg	

P3N-102	300		400		r/min 500		540				
	bar	l/min	kW	l/min	kW	l/min	kW	l/min	kW	l/min	kW
0	57	0.01	75	0.01	94	0.01	102	0.02			
10	57	0.98	75	1.31	94	1.64	102	1.78			
20	57	1.99	75	2.57	94	3.16	102	3.53			
30	57	2.87	75	3.90	94	4.85	102	5.22			
40	57	3.90	75	5.22	94	6.47	102	7.06			
50	57	4.84	75	6.47	94	8.16	102	8.82			
60	57	5.88	75	7.87	94	9.78	102	10.59			
Rotation per min.	r/min	Capacity				l/min	Suction height			0,0 m	
Power consumption	kW	Max. pressure				60bar	Weight			57,5 kg	



# Measure and weight

LP-CANNON

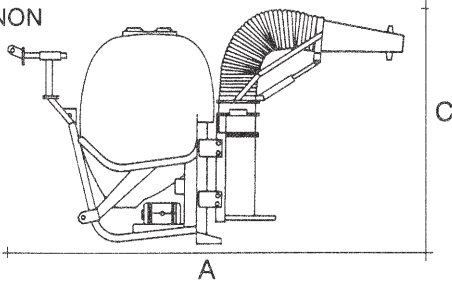

TP-CANNON

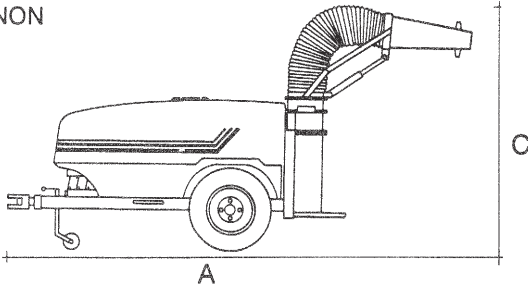

LP

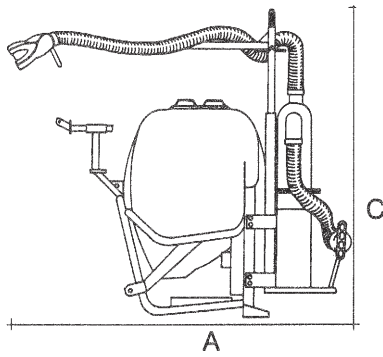

TP

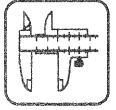
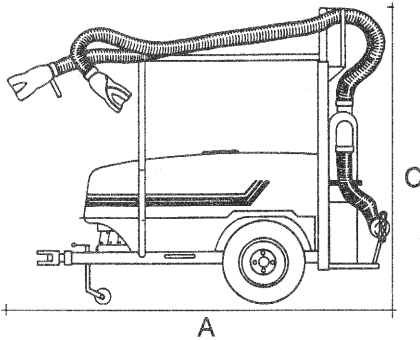

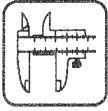

Model	Tank l	Blower ø mm	Air volume m <sup>3</sup> /h	Air speed average m/s	Pump model	Power consumption kW*	Dimensions A x B x C min. cm	Weight kg	Track width min/max mm
LP3S4M	300	540	11880	110	600		179 x 89 x 190	206	-
LP4S4M	400	540	11880	110	600		179 x 89 x 190	208	-
LP5S6M	500	540	11880	95	600		242 x 127 x 200	241	-
LP6S6M	600	540	11880	95	600		242 x 127 x 200	245	-
TP6S4HY	600	540	11880	110	P3XA	19	259 x 110 x 226	475	890-1290
TP8S4HY	800	540	11880	110	P3XA	19	259 x 111 x 233	525	900-1300
TP10S4HY	1000	540	11880	95	P3XA	19	279 x 132 x 227	563	1080-1480
TP15S4HY	1500	540	11880	95	P3N	20	315 x 134 x 231	672	1200-1600
TP20S4HY	2000	540	11880	95	P3N	20	343 x 1460x 231	718	1200-1600
LP4-CANNON	400	500	4770	40	P3X	15	155 x 118 x 170	248	-
LP5-CANNON	500	500	4770	40	P3X	15	155 x 136 x 170	252	-
LP6-CANNON	600	500	4770	40	P3X	15	155 x 136 x 170	257	-
LP4-CANNON	400	540	11880	70	P3N	19	137 x 170 x 215	162	-
LP5-CANNON	500	540	11880	70	P3N	19	137 x 189 x 182	167	-
LP6-CANNON	600	540	11880	70	P3N	19	137 x 189 x 182	171	-
LP4-CANNON	400	540D	20000	62	P3N	37	180 x 190 x 210	207	-
LP5-CANNON	500	540D	20000	62	P3N	37	180 x 190 x 210	210	-
LP6-CANNON	600	540D	20000	62	P3N	37	185 x 190 x 210	215	-
TP10-CANNON	1000	540	11880	70	P3N	20	378 x 132 x 216	546	1080-1480
TP15-CANNON	1500	540	11880	70	P3N	20	414 x 134 x 220	620	1200-1600
TP20-CANNON	2000	540	11880	70	P3N	20	442 x 146 x 220	665	1200-1600
TP10-CANNON	1000	540D	20000	62	P3N	37	378 x 132 x 216	590	1080-1480
TP15-CANNON	1500	540D	20000	62	P3N	37	414 x 134 x 220	665	1200-1600
TP20-CANNON	2000	540D	20000	62	P3N	37	442 x 146 x 220	712	1200-1600

\*Stated at 540 r/min with pump pressure at 20 bar for piston pump

**Air volume**

**P500 Gear ratio 1:5.12**

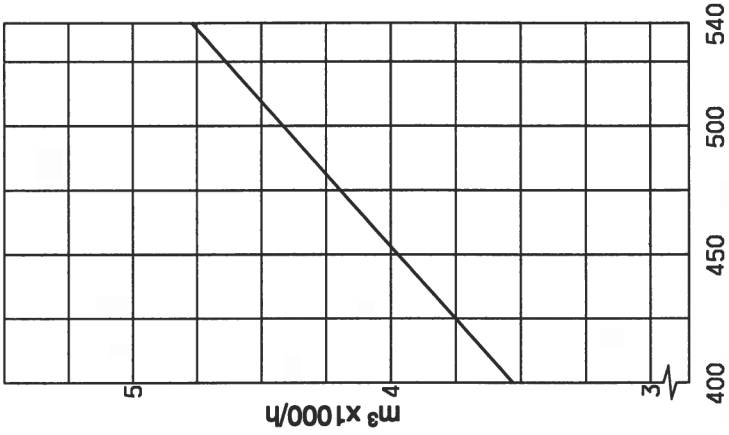

P.T.O. r/min

**P540 Gear ratio 1:7.07**

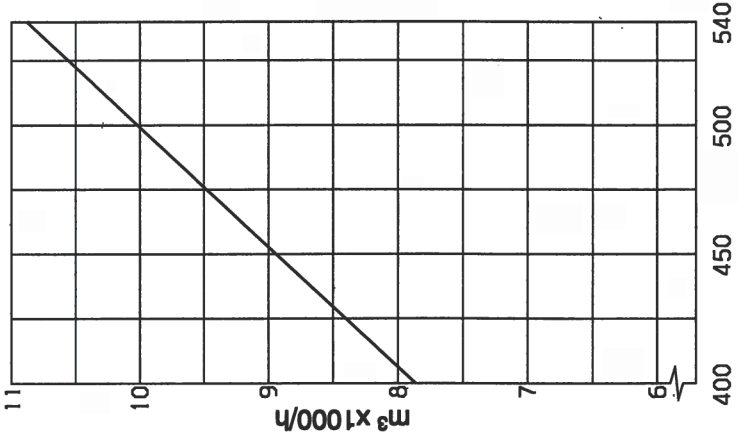

P.T.O. r/min

**P540D Gear ratio 1:7.07**

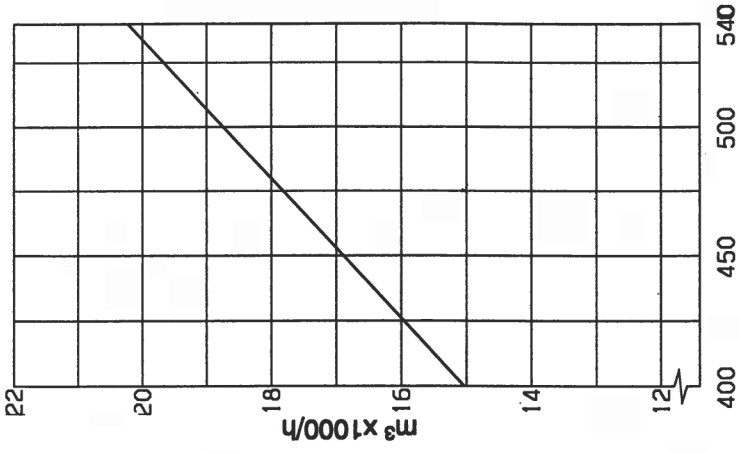

P.T.O. r/min



### Materials and recycling

Tank	HDPE or PU
Hoses	PVC or rubber
Valves	mainly glass-filled PA.
Fittings	PA

### Disposal of the equipment

When the HARDI equipment has completed its working life, it must be thoroughly cleaned. The tank, hose and synthetic fittings can be incinerated at an authorized plant. The metallic parts can be scrapped. Always follow local legislation regarding disposal.



### Pictorial symbols



Description



Service/adjustment



Winter storage



Function



Liquid flow



Operational problems



Connection



Pressure



Technical specifications



Warning



Cleaning



EU Declaration of Conformity



Operating



Lubrication