



FLEXHAUL TRACK SYSTEMS

OPERATORS MANUAL

Table of Contents

Introduction.....	3
Track System Terminology.....	3
Installing Track System.....	4
Adjusting Track System.....	7
Maintaining Track System.....	10
Warranty Information.....	13
Service Parts Information.....	13

Introduction

Thank you for purchasing a Camoplast Flexhaul Track System. This manual provides important installation and maintenance instructions to maximize the benefits of the track system and to ensure performance in the field for many years.

IMPORTANT:
When working on or servicing pull behind carts and/or implements, follow all manufacturers recommended safety precautions.

Track System Terminology

In this operator's manual, several references are made to the track system components. One should become familiar with the terms below before reading further.

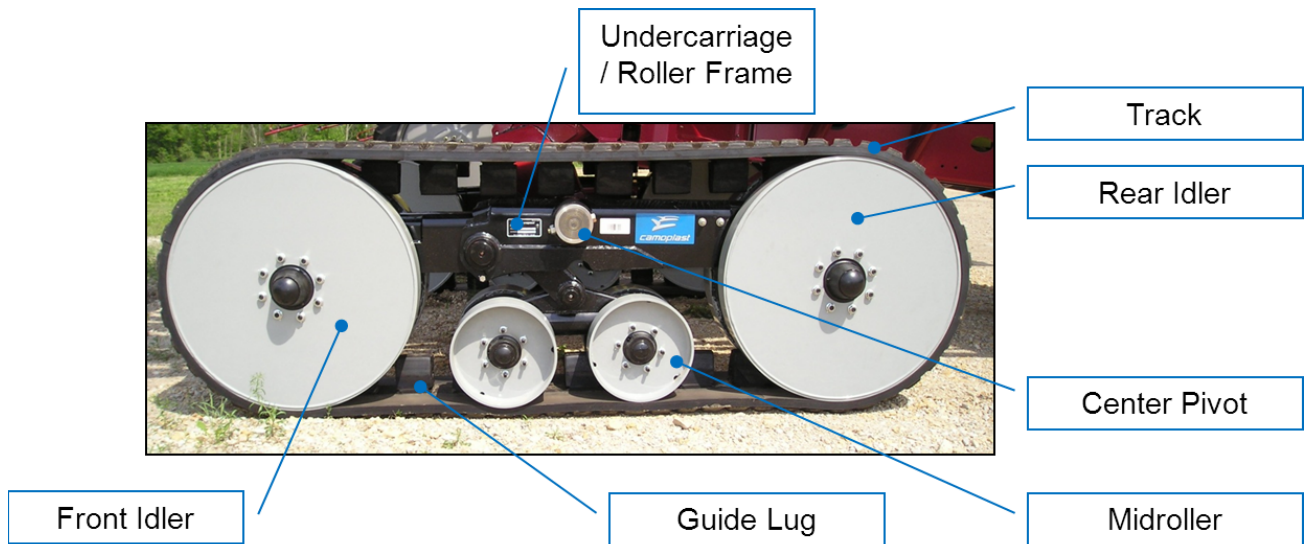

Installing Track System

1. Clean the cart thoroughly before proceeding with the installation. Removal of dirt and debris makes access to the frame and attaching fasteners easier.
2. Move the cart to a hard, level surface to ensure a stable work area to support the cart during the track system installation.

IMPORTANT: Locate the identification tags, as shown below, on both undercarriages, and record the model number and serial numbers on the warranty certificate for your records.

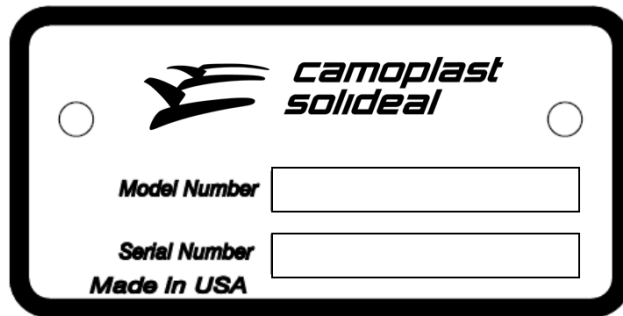

3. Raise and securely support the cart such that the rear tires are just off the ground.
4. Remove the tire and rim assemblies.
5. Remove the axle and hub assemblies from the cart frame.
6. Install track fitment axle. For two bogie track systems, make sure the stabilizer brackets on the axle are facing to the front of the cart. Tighten mounting hardware.

7. Insert center pivot pin into the receiver end of the axle. Rotate the pin to align the rear mounting hole in the receiver pin. Install the bolt and locknut provided with the kit. Tighten pin bolt.
 8. Install the inner o-ring on the center pin and locate nearest the axle receiver end.
 9. Apply a light amount of grease to the center pivot pin.
 10. Ensure the center pin bushings are installed and located in the undercarriage frame properly. Using a fork truck, lift the undercarriage assembly onto the center pivot pin making sure the bushings are not binding with the pin. Slide undercarriage onto pin.
- IMPORTANT: Make sure undercarriage is installed with track tensioner assembly (spring or air bag version) positioned to the rear of the cart. DO NOT install the track system with the tensioner positioned to the front of the cart.**
11. Install the outer o-ring on the center pin and place it up against the face of the pin bushing.
 12. Install the lock collar on the center pivot pin. Align the hole in the lock collar with the pin and install the bolt and locknut provided with the kit. Tighten lock collar bolt.

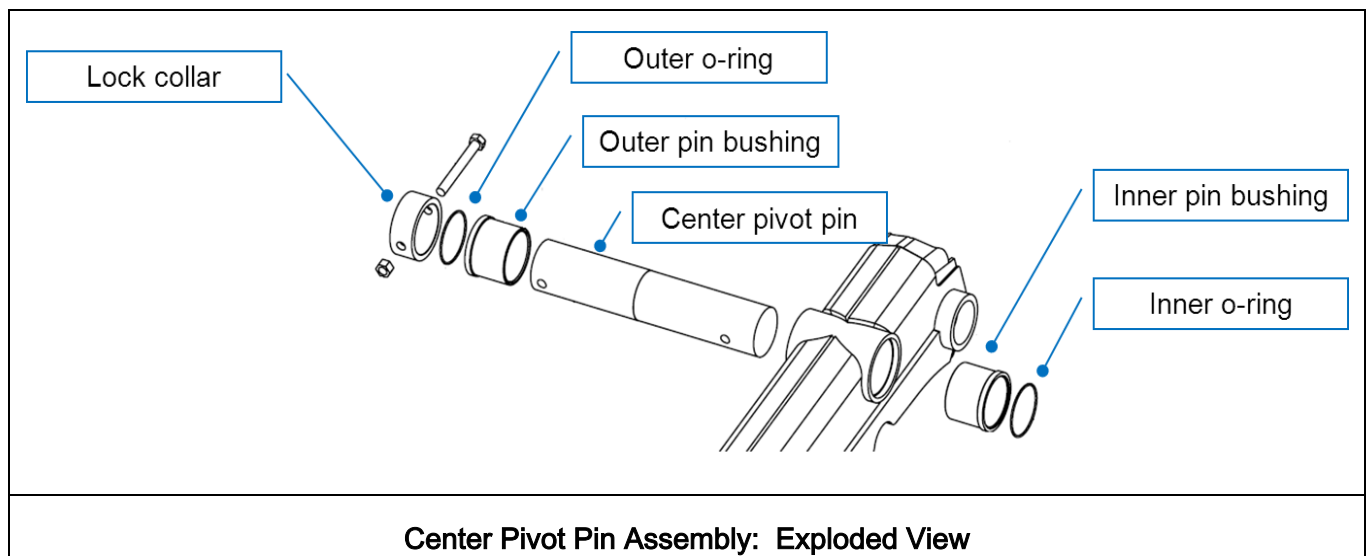

13. Repeat steps 7 through 12 for the other side.
14. Remove jack stands and/or supports and lower cart to the ground.
15. Locate the recessed grease zerk on each of the roller frames underneath the center pivot pin mounts. Apply grease using NLGI GC-LB equivalent.
16. Install the stabilizer bars, “turnbuckles”. Once installed, adjust the stabilizers to a no pre-load condition. Some play should be present at the rod ends.
 - a) For 2 bogie track systems, attach the two, front stabilizer bars to the mounting brackets on the axle and the brackets on undercarriage frame with the hardware provided in the kit.
 - b) For 4 bogie track systems, attach the two, front stabilizer bars and two, rear stabilizer bars to the mounting brackets on the axle and the brackets on undercarriage frame with the hardware provided in the kit.
17. Locate grease zerks on each stabilizer bar. Apply grease using NLGI GC-LB equivalent.
18. Check and re-torque all wheel lug nuts as follows:

Wheel stud diameter	Torque
1/2"	80 +/- 10 lb-ft
5/8"	160 +/- 10 lb-ft

Adjusting Track System

1. Prior to checking track alignment, locate the track tensioner assembly mounted underneath the undercarriage frame in between the rear idler wheels.
 - a) For 1 and 2 bogie track systems with a spring tensioner assembly, the spring is set from the factory with minimal preload and is normal for operation.
 - b) For 2 bogie systems with an air bag tensioner assembly, the air bag should be pressurized to 50 +/- 5psi.
 - c) For 4 bogie systems with an air bag tensioner assembly, the air bag should be pressurized to 70 +/- 5psi.
2. Pull the cart on a flat surface and in a straight line for approximately 300 ft. Coast to a stop and avoid sudden braking.
3. At the first set of midrollers, check the location of the guide lug relative to the inside and outside of the midrollers. If the guide lugs are rubbing the inner or outer wheels, then an alignment adjustment is necessary.
4. Locate the track alignment assembly mounted underneath the frame in between the front idler wheels.

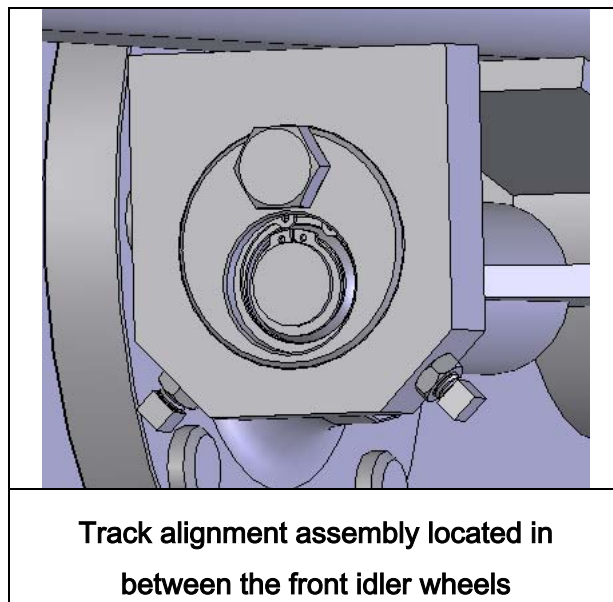

5. Loosen the two, jam nuts and the two, set screws located on the lower part of the block.

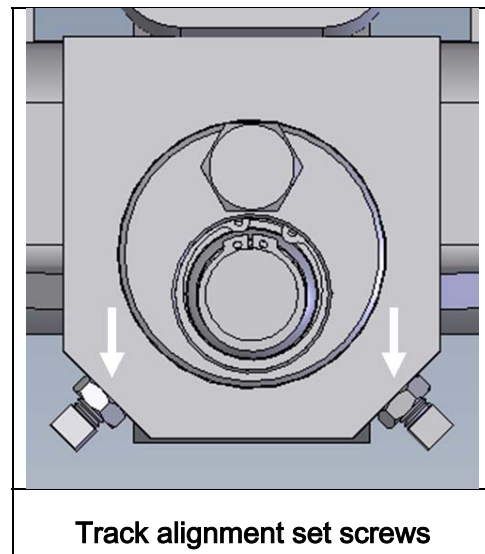

6. Place a socket wrench on the 15/16" hex pin and rotate the adjuster in small increments as follows (note: maximum adjustment is reached at 90 degrees from top dead center):
- a) To move the track to the left, rotate the adjuster CCW (counter clockwise).
 - b) To move the track to the right, rotate the adjuster CW (clockwise).
 - c) Or, simply, turn the adjuster away from the side rubbing or interfering.

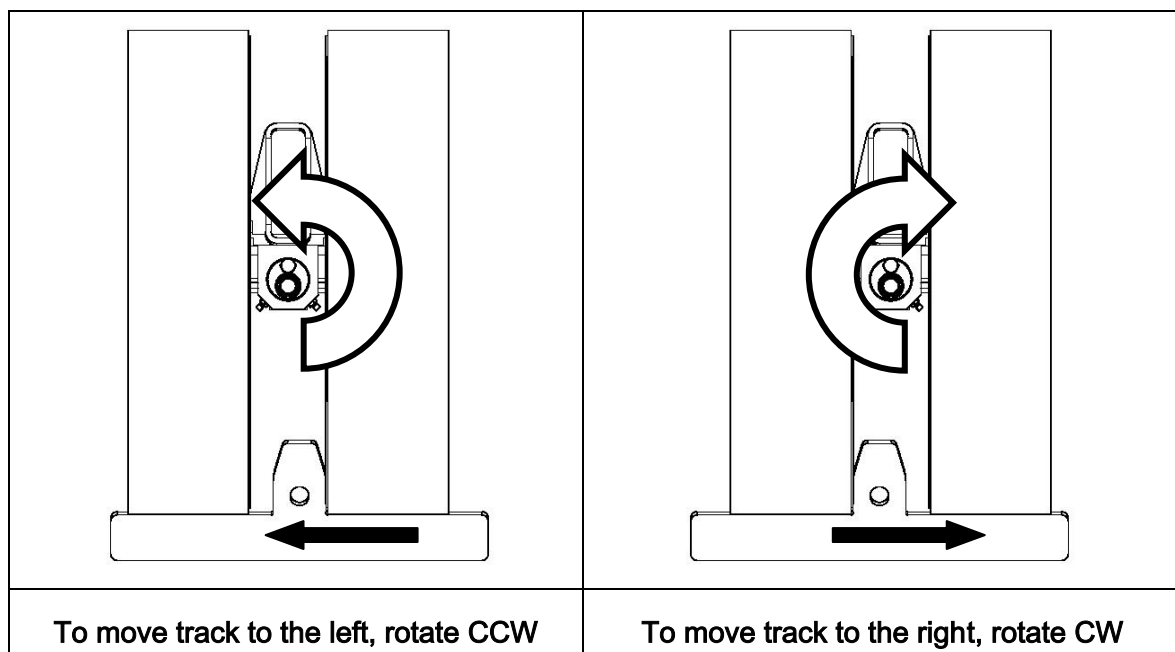

NOTE:

If the adjuster is difficult to turn, then back off the track tension or take weight off the front idler wheels to allow movement of the adjuster.

7. Tighten the two set screws and jam nuts.

8. Repeat steps 2 through 7 until alignment is achieved. Note: The track system was designed to use a relatively low track tension setting. This lower track tension results in the track moving side to side depending on loading conditions as well as ground conditions. Set the alignment such that the guide lugs are close to centered but, more importantly, not rubbing or interfering with any one side of the wheel package.

Maintaining Track System

The Flexhaul track systems are designed for ease of serviceability and maintenance. To avoid downtime and maximize track system life, Camoplast recommends the following maintenance schedule.

Task	Daily	Every 50 HRS	Every 100 HRS
Clean and remove debris build-up from undercarriages	✓		
Inspect wheel hubs for loose or missing dust caps and wear or damage of inner wheel seals	✓		
Check rubber track alignment based on guide lug wear	✓		
Grease wheel hubs and undercarriage pivot points		✓	
Check track tension			✓
Re-torque wheel lug nuts			✓

Details for these maintenance recommendations are provided below.

- **Clean and remove debris build-up in each of the undercarriages daily.**
Remove debris from main frame, in between wheels, and on outer wheel surfaces.

- Check track alignment daily.

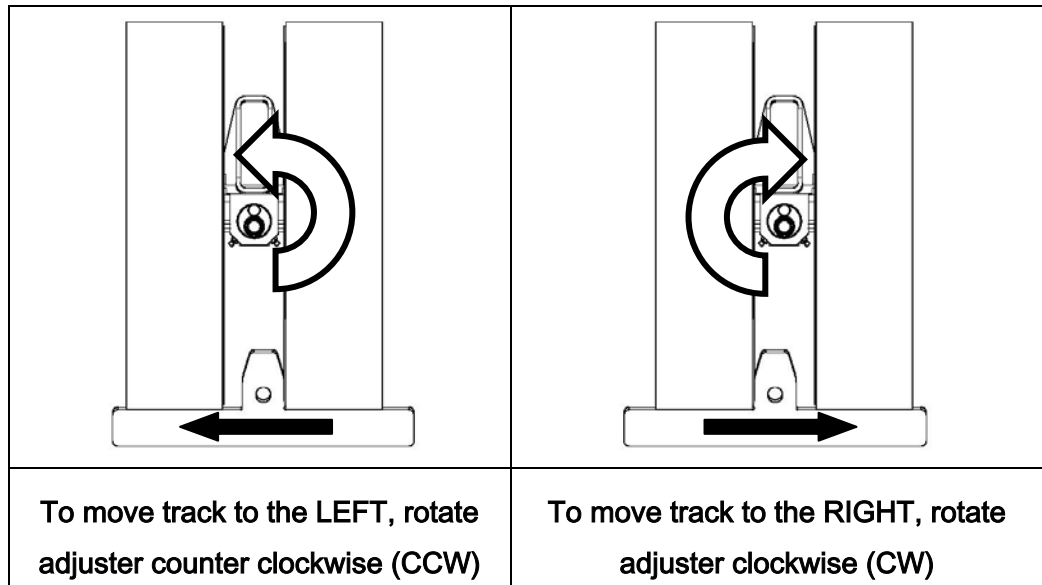

- Grease hubs and pivot points every 50 hrs. Check and repack bearings annually. Use a NLGI GC-LB equivalent grease.

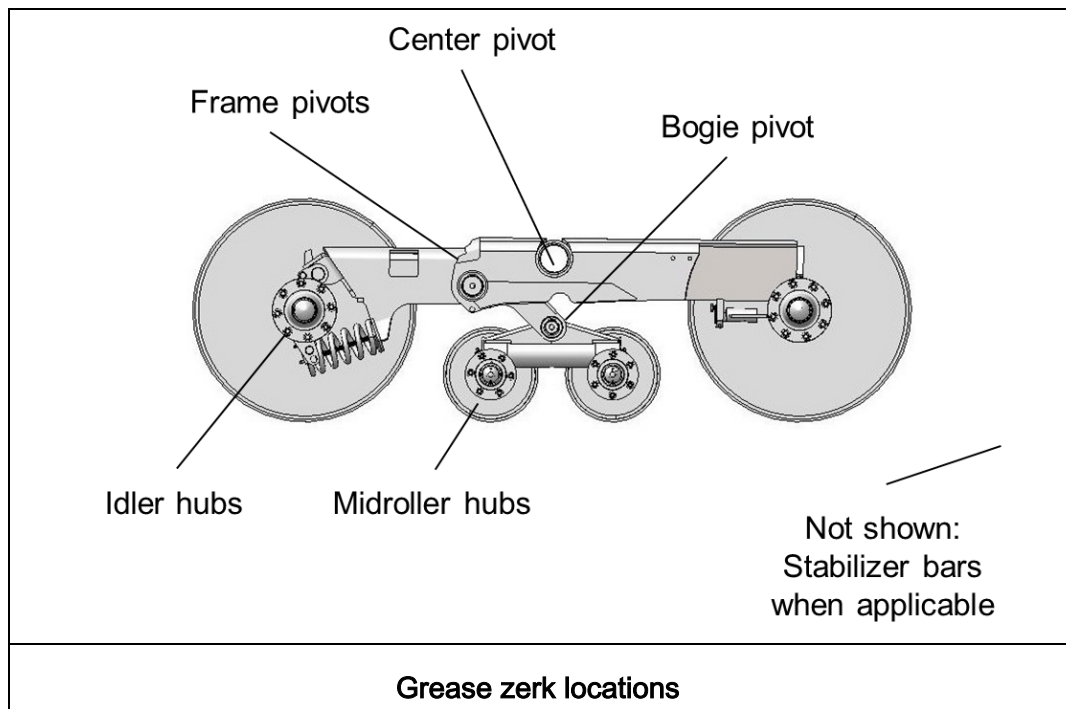

- Check track tension setting every 100 hrs. Depending on track system series and tensioner type, refer to chart below for recommended setting.

Track System	Tensioner Type	Setting
Flexhaul 30 and 40 Series	Spring	No preload. Onset of compression less one full turn
Flexhaul 60 and 70 Series	Air Bag	50 +/- 5 psi
Flexhaul 80 and 100 Series	Air Bag	70 +/- 5 psi

- Re-torque wheel lug nuts every 100 HRS.

Wheel Stud Size	Torque
1/2"	80 +/- 10 lb-ft
5/8"	160 +/- 10 lb-ft

Warranty Information

After completing the track system installation and rubber track alignment, make sure to review the following documents included with your literature packet:

- Track System Operational Guidelines brochure
- Warranty certificate
- Warranty registration card

Please take a few minutes to review the information in the brochure and the warranty certificate. Also, complete the warranty registration card and send it in.

Service Parts Information

For service replacement parts, please contact your authorized Camoplast Flexhaul dealer.