

GLOBAL RANGER

Instruction book

67021203 - Version 1.00

US - 07.2006

HARDI® reserves the right to make changes in design, material, or specification without notice thereof.
HARDI® and other product names are registered trademarks of HARDI® Inc. in the U.S. and in other countries.

1 - Welcome	
Welcome letter	1
2 - Safety notes	
Operator safety	1
General info.....	1
Local poison information center	3
3 - Description	
General info	1
View	1
View	2
Identification plates.....	2
Roadworthiness	2
Sprayer use.....	3
Frame.....	3
Tank.....	3
Liquid system	4
General info - MANIFOLD system.....	4
Pump	4
Valves and symbols	4
Green valves - Green disc = Pressure valve.....	5
Black valves - Black disc = Suction valve.....	5
Electrical operated MANIFOLD valves (optional equipment)	5
Diagram - Diaphragm Liquid system.....	6
Diagram - Centrifugal Liquid system	7
Control unit	7
Filters.....	7
CycloneFilter.....	8
HARDI® FILLER.....	9
Agitation/Tank Rinse valve.....	9
Boom	10
Boom and terminology.....	10
Equipment	11
Step (optional)	11
Platform	11
Tank level indicator	11
Remote pressure gauge	12

Table of contents

4 - Sprayer setup

General info	1
Unloading the sprayer from the truck.....	1
Before putting the sprayer into operation.....	1
Support jack.....	1
Mechanical connections	2
Hitch - Height adjustment.....	2
Transmission shaft - Operator's safety.....	2
Transmission shaft - Installation	2
Hydraulic systems	4
General info.....	4
Requirements - tractor (SPB-HY & SPB-HZ)	4
Electrical connections	5
Power supply.....	5
Control boxes.....	5
Installation of control unit brackets	5
Installation of 'D.H.' control unit - Hydraulics (HZ only).....	6
Installation of joystick handle - Hydraulics (HZ only).....	6
Installation of control box - EVC control unit	7
Road safety kit.....	7
Track width, axles and wheels	8
Altering the track width.....	8
Turning rim and rim plate	8

5 - Operation

Boom	1
Safety info.....	1
Maneuvering of the boom - HY version	1
Maneuvering of the boom - HZ version with Joystick control.....	2
Boom tilt function - Joystick control	2
Maneuvering of the boom - HZ version with 'DH' control.....	3
Boom tilt function - 'DH' control.....	3
Folding one side only (HZ Hydraulics only).....	4
Liquid system	5
Filling of water	5
Filling through tank lid	5
Suction filling device (optional - main tank only).....	6
Filling of main tank using Quick Fill (optional).....	7
Filling of flush tank using Quick Fill (optional).....	7
Filling of clean water tank.....	8
Adjustment of EVC operating unit	8
Safety precautions - crop protection chemicals.....	9
Filling chemicals through tank lid.....	10
Filling Liquid chemicals by HARDI® FILLER.....	11
Filling Powder chemicals by HARDI® FILLER.....	12
Agitation before re-starting spraying.....	13
Operating the control unit while spraying.....	13
Quick reference - Operation	14
Cleaning	15
General info.....	15
Cleaning the tank and liquid system	16
Cleaning and maintenance of filters	16
Use of flush tank and rinsing nozzles	17
Quick reference - Cleaning	18
Technical residue.....	18
Using the drain valve.....	18
Spray Technique - see separate book.....	18
Optional extras - see separate books.....	18

6 - Maintenance

Lubrication	1
General info	1
Recommended lubricants	1
Boom lubrication & oiling plan	1
Trailer lubrication & oiling plan	2
Service and Maintenance intervals	3
10 hours service - Suction filter	3
10 hours service - Cyclone filter	3
10 hours service - In-Line filter (optional equipment)	4
10 hours service - Nozzle filters	4
10 hours service - Spraying circuit	4
50 hours service - Transmission shaft	4
50 hours service - Wheel bolts and nuts	4
50 hours service - Tire pressure	5
250 hours service - Readjustment of the boom	5
250 hours service - Hydraulic circuit	5
250 hours service - Hoses and tubes	5
250 hours service - Wheel bearings	5
1000 hours service - Transmission shaft	5
1000 hours service - Wheel bearings	6
Occasional maintenance	7
General info	7
Pump valves and diaphragms replacement	7
Pump valves and diaphragms replacement	8
Cone check/replacement for EVC operating unit	8
Cone check/replacement for EVC distribution valve	9
Level indicator adjustment	9
Level indicator cord replacement	9
Drain valve seal replacement	10
Nozzle tubes and fittings	10
Adjustment of 3-way-valve	10
Readjustment boom - general info	11
Alignment of center and inner wing sections	11
Alignment of inner and outer wing sections	11
Adjusting the front fold cable	12
Breakaway section adjustment	12
Check/adjust sprocket timing	13
Adjusting boom level to ground	13
Adjusting rear cable	14
Adjusting center section cable	14
Shock absorbers	15
Wear bushing replacement on boom lift	15
Change of tire	15
Change of bulbs	16
Shield replacement on transmission shaft	16
Replacement of transmission shaft cross journals	16
Off-season storage	17
Off-season storage program	17
Preparing the sprayer for use after storage	17

Table of contents

7 - Fault finding

Operational problems	1
General info	1
Liquid system	2
Hydraulic system - HY model	3
Hydraulic system - HZ model	3
Mechanical problems	4
Mechanical problems.....	4
Emergency operation - Liquid system.....	4

8 - Technical specifications

Dimensions	1
Overall dimensions	1
Specifications.....	1
Weight.....	1
Wheel and axle dimensions.....	1
Specifications	2
Diaphragm pumps.....	2
Pump model 1303/9.0.....	2
Pump model 363/5.5.....	2
Pump model 363/10.0.....	2
Pump model 463/6.5.....	2
Pump model 463/12.0.....	2
Centrifugal pumps.....	2
Pump model ACE 206 hydraulic	2
Pump model ACE 150 PTO drive.....	2
Filters and nozzles	3
Temperature and pressure ranges	3
Tire pressure	3
Materials and recycling	3
Disposal of the sprayer.....	3
Electrical connections	4
Rear lights	4
Electrical connections for SPRAY II.....	5
EVC	6
HC 2500.....	7
HC 5500.....	7
Charts	8
Boom hydraulics - HY.....	8
Boom hydraulics - HZ.....	8
Boom hydraulics - DH.....	9

9 - Warranty

Warranty policy and conditions	1
---	----------

Welcome letter



Dear Owner,

Thank you for purchasing a HARDI® product and welcome to the ever-increasing family of HARDI® sprayer owners.

Our sprayers and accessories are rapidly becoming a familiar sight on North American farms. We believe that this results from growers becoming increasingly conscious of crop protection input costs and the vital need for cost effective spray application equipment.

Please take the time to thoroughly read the Operator's Manual before using your equipment. You will find many helpful hints as well as important safety and operation information.

Some of the features on your HARDI® sprayer were suggested by growers. There is no substitute for "on farm" experience and we invite your comments and suggestions. If any portion of this instruction book remains unclear after reading it, contact your HARDI® dealer or service personnel for further explanation before using the equipment.

For Product, Service or Warranty Information:

- Please contact your local HARDI® dealer.

To contact HARDI® directly:

- Please use the HARDI® Customer Service number: 1-866-770-7063

- Or send your email to CUSTSERV@hardi-us.com

HARDI® Inc.

HARDI® MIDWEST
1500 West 76th St.
Davenport, Iowa 52806
Phone: (563) 386-1730
Fax: (563) 386-1710

HARDI® GREAT LAKES
290 Sovereign Rd.
London, Ontario N6M 1B3
Phone: (519) 659-2771
Fax: (519) 659-2821

Visit us online at: www.hardi-us.com

HARDI® WEST COAST
8550 W. Roosevelt Avenue
Visalia, California 93291
Phone: (559)651-4016
Fax: (559) 651-4160

Sincerely,

A handwritten signature in black ink, appearing to read "Tom L. Kinzenbaw".

Tom L. Kinzenbaw
President

Operator safety



This symbol means DANGER. Be very alert as your safety is involved!



This symbol means WARNING. Be alert as your safety can be involved!



This symbol means ATTENTION. This guides to better, easier and safer operation of your sprayer!

General info

Note the following recommended precautions and safe operating practices.



Read and understand this instruction book before using the equipment. It is equally important that other operators of this equipment read and understand this book.



Local law may demand that the operator is certified to use spray equipment. Adhere to the law.



Wear protective clothing.



Rinse and wash equipment after use and before servicing.



Never service or repair the equipment while it is operating.



Always replace all safety devices or shields immediately after servicing.



Do not eat, drink or smoke while spraying or working with contaminated equipment.



Wash and change clothes after spraying.

Wash tools if they have become contaminated.



In case of poisoning, immediately seek medical advice. Remember to identify chemicals used.



Keep children away from the equipment.



If any portion of this instruction book remains unclear after reading it, contact your HARDI® dealer for further explanation before using the equipment.



Be careful not to hit people or surroundings when maneuvering the sprayer, especially when backing.



Slow down when driving in uneven terrain, as the machine might be in risk of turning over.

2 - Safety notes



Pressure test with clean water prior to filling with chemicals.



Disconnect electrical power before servicing and depressurize equipment after use and before servicing.



Do not attempt to enter the tank.



Do not go under any part of the sprayer unless it is secured. The boom is secure when placed in the transport brackets.



If an arc welder is used on the equipment or anything connected to the equipment, disconnect power leads before welding. Remove all inflammable or explosive material from the area.

Local poison information center



If you live anywhere in the United States, the following toll free number will connect you to your Local Poison Information Center.

PHONE NO. 1 - 800 - 222 - 1222



If you live outside the United States, find the number for the poison control center in your phone book and write it in the space below:

PHONE NO. _____ - _____ - _____



Keep a list, in the space provided below, of all the chemicals that you have in use.

1. _____
2. _____
3. _____
4. _____
5. _____
6. _____
7. _____
8. _____
9. _____
10. _____

2 - Safety notes

General info

View

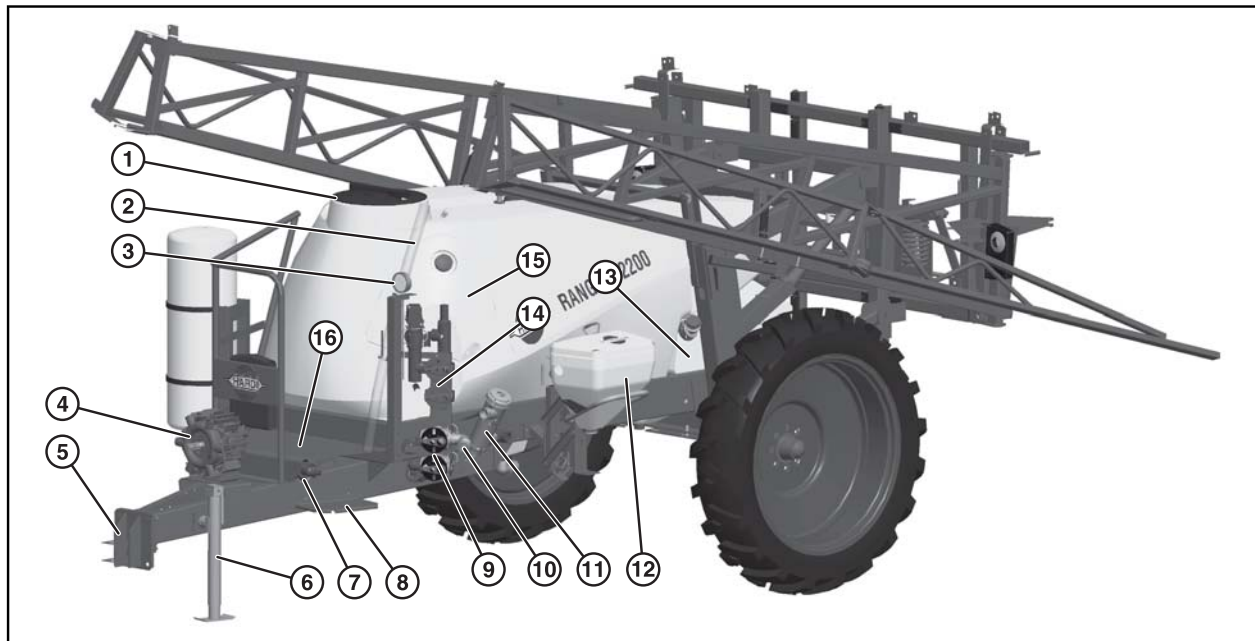

1. Main tank lid
2. Tank level indicator
3. Spray pressure gauge
4. Pump
5. Hitch
6. Support jack
7. Suction filter
8. Step

9. Suction manifold
10. Quick Fill
11. Cyclone filter
12. HARDI® FILLER
13. Flush tank
14. Pressure manifold
15. Clean water tank
16. Platform

3 - Description

View

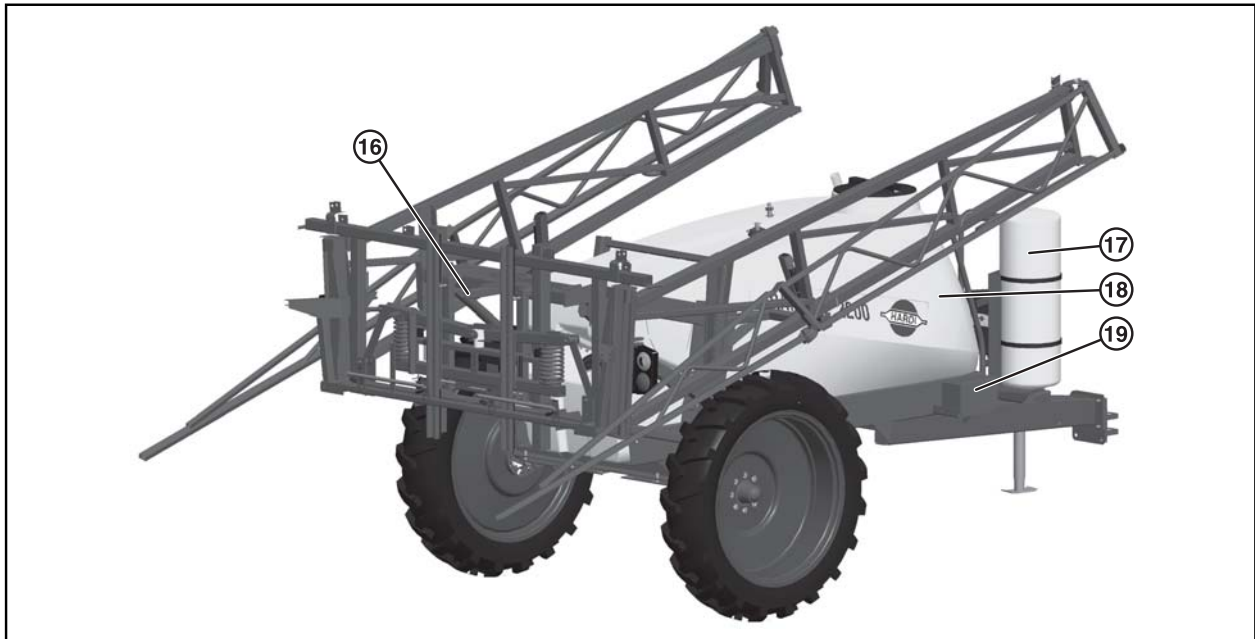

16. Distribution valves

17. Foam marker tank

18. Main tank

19. Foam marker compressor

Identification plates

An identification plate fitted on the frame indicates producer name, model and serial number.

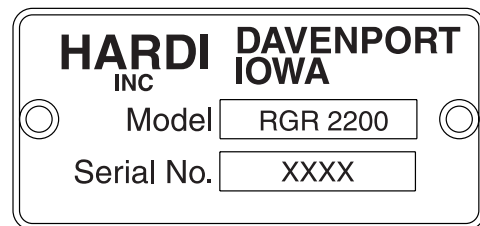

Frame, boom center frame and other main steel components have identification plates indicating type and part number. (not illustrated)

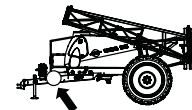

Roadworthiness

When driving on public roads and other areas where the highway code applies, or areas where there are special rules and regulations for marking and lights on implements, you should observe these and equip implements accordingly.



ATTENTION! Max. driving speed is 25 mph (40 km/h). Be aware that this may differ due to local law. Contact local authorities for information of max. driving speeds.

Sprayer use

The HARDI® sprayer is for the application of crop protection chemicals and liquid fertilizers. The equipment must only be used for this purpose. It is not allowable to use the sprayer for other purposes. If no local law demands that the operator must be certified to use spray equipment, it is strongly recommended to be trained in correct plant protection and in safe handling of plant protection chemicals to avoid unnecessary risk for persons and the environment when doing your spray job.

Frame

Very strong and compact frame which also has a strong chemical and weather resistant electrostatic powder coat. Screws, nuts, etc. have been DELTA-MAGNI treated to be resistant to corrosion.

Tank

The main tank made of impact-proof, UV-resistant and chemical resistant polyethylene, has a purposeful design with no sharp corners for easy cleaning. Nominal contents 600 gal (2200 liters). A large, easy to read, tank contents indicator is placed beside the platform and is visible from the tractor cabin. The filling hole is placed so it can be accessed from the platform. This ensures an easy access for filling, cleaning of the tank, etc. The sprayer is also equipped with a flush tank and a clean water tank.

3 - Description

Liquid system

General info - MANIFOLD system

The functions of the spray circuits are operated via the centrally located MANIFOLD valves with color coded plates and pictorial symbols for easy operation.

The modular MANIFOLD system facilitates the addition of optional extras on both pressure side and suction side.

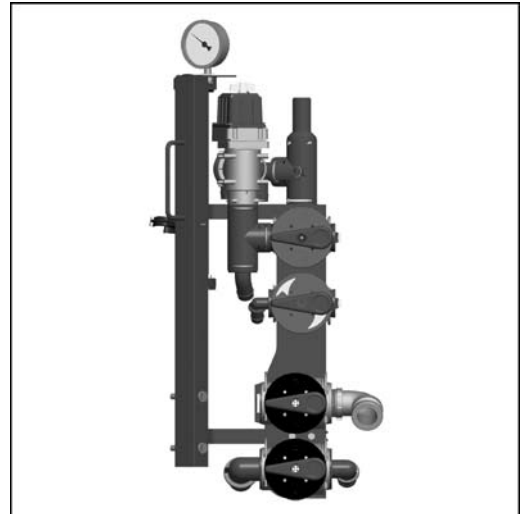

Pump

Diaphragm pump with easily accessible valves and diaphragms. Model 1303 with 3 diaphragms, 540 r.p.m. (6 splines). Model 363 or 463 with 6 diaphragms. Standard = 540 r.p.m. (6 splines). Optional = 1000 r.p.m. (20 or 21 splines).

Centrifugal pump, model 206 (hydraulic) or 150 (PTO). Standard = 540 r.p.m. (6 splines). Optional = 1000 r.p.m. (20 or 21 splines).

Valves and symbols

The valves at the MANIFOLD are distinguished by colored identification discs on the valves. Symbols corresponding to every possible function of use are located on the discs for easy identification and operation. A function is activated by turning the handle towards the desired function.



ATTENTION! Only the functions in use should be open - always close remaining valves.



ATTENTION! If a MANIFOLD valve is too tight to operate - or too loose (= liquid leakage) - the valve needs to be serviced. Please see the section 'Maintenance' for further information.

3 - Description

Green valves - Green disc = Pressure valve



To Spray Boom



To HARDI® FILLER



To Agitation



To Tank Rinsing Nozzle

The position of the pressure manifold valves determine the direction of flow of liquid from the pump. When the arrow on the handle is pointing towards a symbol, the liquid will flow to that symbol's corresponding device (i.e. Chemfiller). When the arrow on the handle is pointing towards "O", the valve is closed. If all the green pressure valves are closed in a diaphragm pump system, the safety valve will open to allow liquid to flow back to the tank.

The bottom pressure manifold valve is adjustable. The valve is marked with an arrow on the green disc that indicates the amount of liquid that passes through the valve. This allows for a continuously variable flow to agitation or tank rinsing.

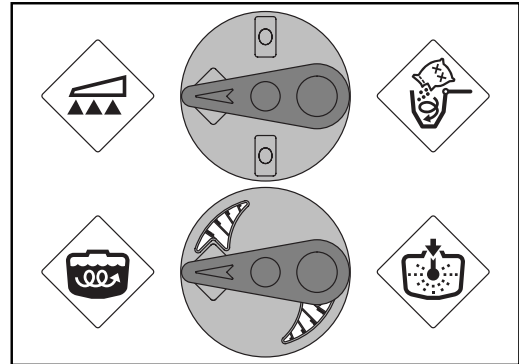

Black valves - Black disc = Suction valve



From main tank



From flush tank



From Quick Fill

The position of the suction manifold valves determine the source of the liquid. When the arrow on the handle is pointed towards a symbol, the source of liquid correspond's to that symbol's device (i.e. Main tank) When the arrow on the handle is pointing towards "O", the valve is closed.

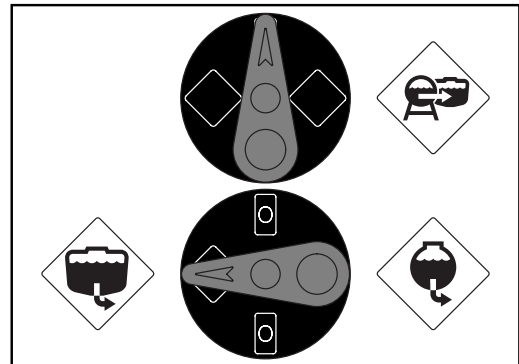

Electrical operated MANIFOLD valves (optional equipment)

One or more MANIFOLD valve(s) can be electrically operated via a control box in the tractor cabin. These can only be operated manually if the power to the valve motor is disconnected.

3 - Description

Diagram - Diaphragm Liquid system

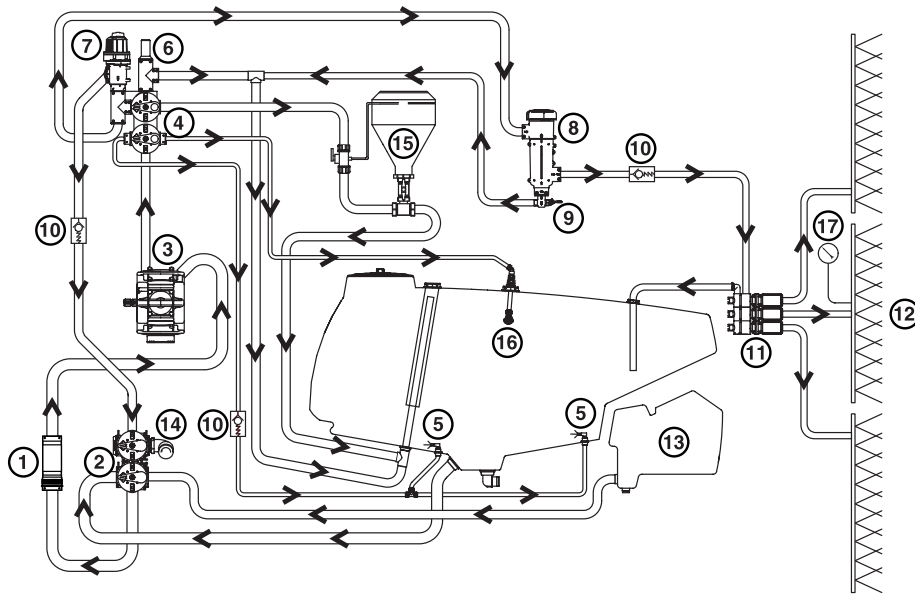

- 1. Suction filter (optional)
- 2. Suction manifold
- 3. Pump
- 4. Pressure manifold
- 5. Agitation
- 6. Safety valve
- 7. HARDI-MATIC
- 8. Cyclone filter (optional)
- 9. Off/On/Purge valve

- 10. Check valves
- 11. Boom section valves
- 12. Boom
- 13. Flush tank (optional)
- 14. Quick fill (optional)
- 15. HARDI® FILLER (optional)
- 16. Tank rinse nozzle (optional)
- 17. Boom pressure gauge

Diagram - Centrifugal Liquid system

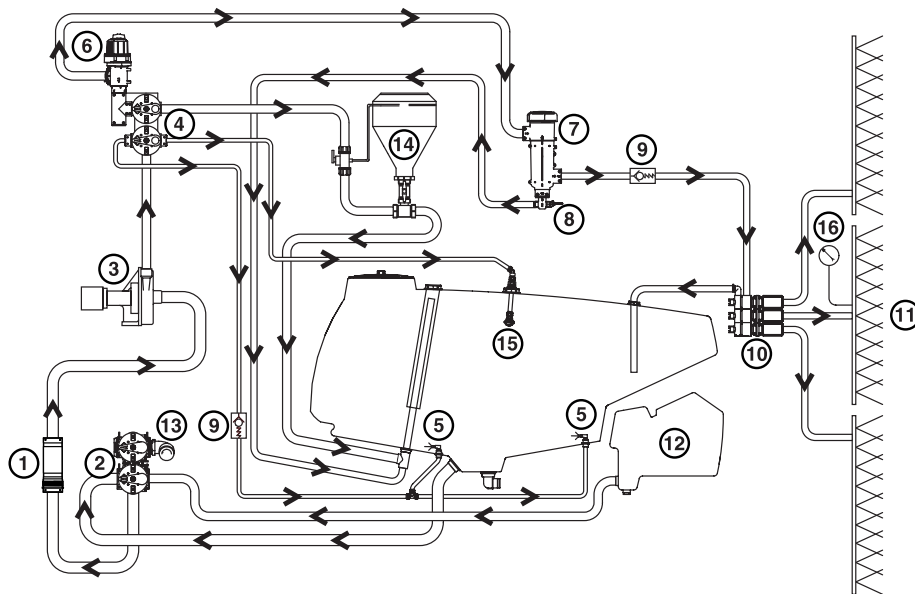

- | | |
|------------------------------|----------------------------------|
| 1. Suction filter (optional) | 9. Check valve |
| 2. Suction manifold | 10. Boom section valves |
| 3. Pump | 11. Boom |
| 4. Pressure manifold | 12. Flush tank (optional) |
| 5. Agitation | 13. Quick fill (optional) |
| 6. HARDI-MATIC | 14. HARDI® FILLER (optional) |
| 7. Cyclone filter (optional) | 15. Tank rinse nozzle (optional) |
| 8. Off/On/Purge valve | 16. Boom pressure gauge |

Control unit

EVC - Electrical Valve Control. The ON/OFF is linked to the section valves, which results in a very quick response to ON/OFF. The operating unit is constructed of modules and is electrically controlled via a remote control box. The unit is fit with built-in HARDI-MATIC.

Filters

Nozzle filters are fitted at each nozzle. In-line pressure filters can be fitted at each section as an option. A suction filter can also be fitted under the platform.

All filters should always be in use and their function checked regularly. Pay attention to the correct combination of filter mesh size. The mesh size should always be less than the flow average of the nozzles in use.

3 - Description

CycloneFilter

With the CycloneFilter, the impurities that exist in the spray liquid will by-pass the filter and be recirculated back to the tank via the return flow.

Function diagram

1. Filter lid
2. From pump
3. To boom
4. Return to tank
5. Return valve

Valve (5) has three positions marked with small dots on the lever:

Position A (Marked with 1 dot): There is no return flow. Position is used when flushing the boom if there is spray liquid in the main tank. Also used when high spraying volume is required.

Position B (Marked with 2 dots): Normal spraying position. With return flow to prevent clogging the filter when spraying. Position is used when flushing the boom if the main tank is empty.

Position C (Marked with 3 dots): Flushing position, which is used if filter is clogged. Lift and hold the lever to use this position which largely increases return flow and cleans the filter.

See Maintenance section for service of filter.



DANGER! Never open the Cyclone filter unless the top green pressure manifold valve and bottom black suction manifold valve are both closed (turned to the unused position). Otherwise, spraying liquid could hit you when opening the filter, and drain from the tank!

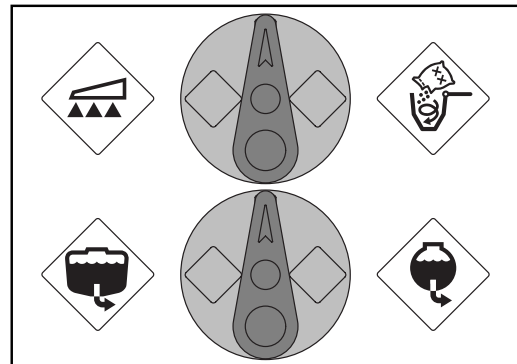
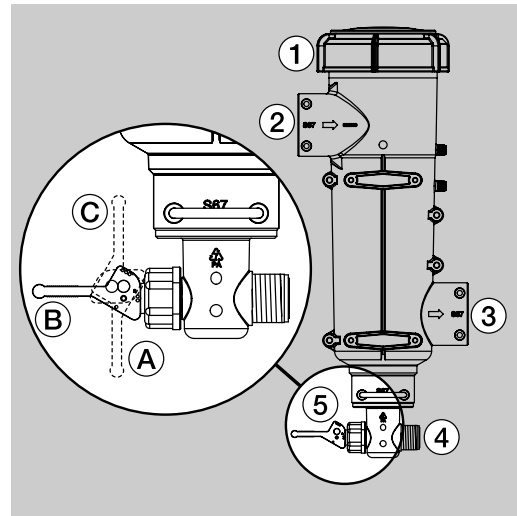

3 - Description

HARDI® FILLER

The HARDI® FILLER is situated on the sprayer's left side, just behind the MANIFOLD valves. The bottom valve (A) is used to empty the hopper. The valve (C) engages the HARDI® FILLER flushing device, used when mixing the chemicals. The lever (B) is used for rinsing the hopper or chemical container cleaning.

See section "Operation" for operating instructions.

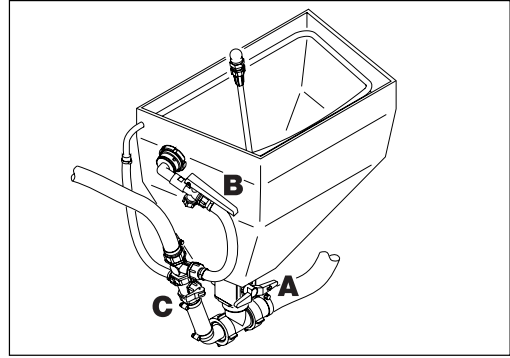

Agitation/Tank Rinse valve

The valve is marked with an arrow on the green disc that indicates the amount of liquid that passes through the valve. If handle is turned to a position near the tip of the arrow, then only a small amount is allowed to pass the valve. Otherwise, if handle is turned to a position in the wide end of the arrow, it means that a larger amount is passing the valve. This gives the possibility to continuously adjust how much fluid from the pump is used for agitation/rinsing in the tank.

Examples on handle positions at different agitation quantities:

1. Handle is in the "widest end of arrow" position (full open).
Agitation quantity is 100%.

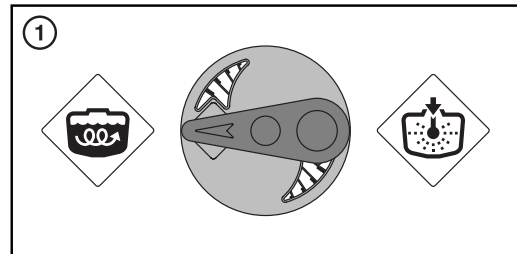

2. Handle is positioned at the middle of the arrow position. Agitation quantity is 50%.

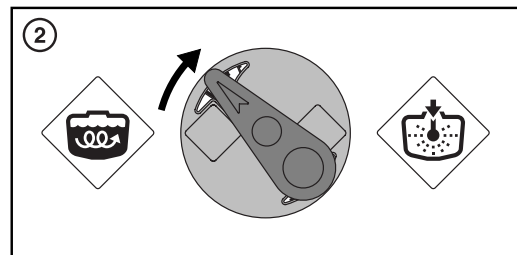

3. Handle is positioned in closed position. Agitation quantity is 0%.

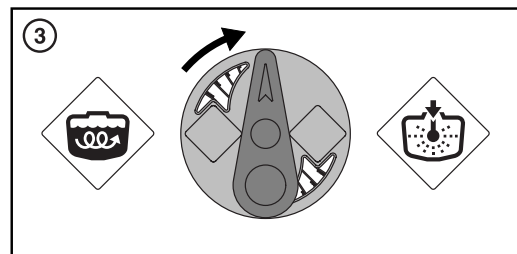

3 - Description

Boom

Boom and terminology

The SPB boom is available in two different hydraulic system versions – both equipped with I.A.H. (Indirect Acting Hydraulics) and named:

1. SPB-HY

This type of boom is operated via the tractor hydraulics. This model features hydraulic lift cylinder for boom height adjustment and two cylinders for simultaneous boom wing fold and unfold.

2. SPB-HZ

This type of boom has the same features as the above mentioned HY-model, but is provided with more advanced hydraulics. SPB-HZ also has two boom wing tilt cylinders that give the ability to obtain individual boom wing tilt as well as individual boom wing fold.

The hydraulics on the SPB-HZ are controlled via a joystick.

Outer sections incorporate spring loaded breakaway and all booms have bi-fold wings.

The SPB boom is available in 45', 50', 60' & 66' working width.

For bi-fold booms the terminology is as follows:

A - Breakaway section

C - Outer section

E - Inner section

F - Center section

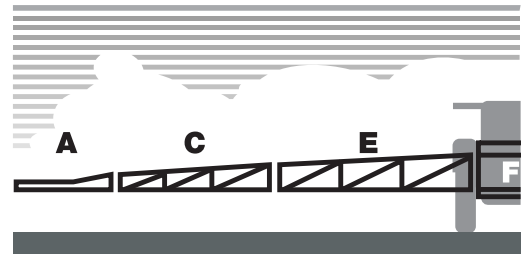

Equipment

Step (optional)

The optional platform step is located on the left side of the sprayer frame to make it easier to climb up to the platform.

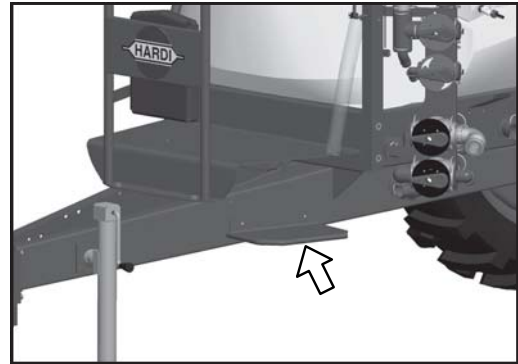

Platform

The platform gives access to the clean water tank lid, the main tank lid and the optional foam marker tank lid.



Tank level indicator

The actual tank level in the main tank can be observed on the tank level indicator. The scale is displayed in US gallons or Liters.



ATTENTION! If very high accuracy is needed, a HARDI® FILL-METER can be fitted as optional equipment.



3 - Description

Remote pressure gauge

The remote pressure gauge is located above the manifold valve on the platform. This gauge measures the working pressure in the boom tubes as close to the nozzles as possible.

The outputs stated in the nozzle charts are always based on the pressure measured at the nozzle. Always adjust pressure when calibrating and spraying according to readings at the remote pressure gauge.

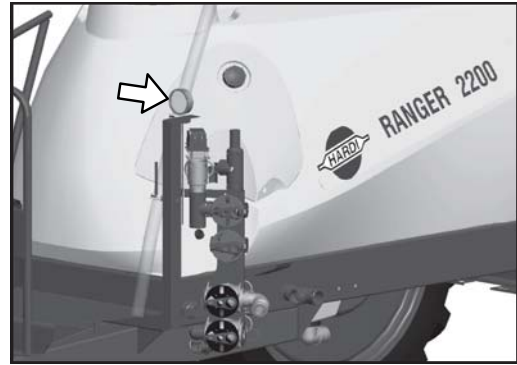

General info

Unloading the sprayer from the truck

When unloading with an overhead lifting device, please observe the lifting points as shown in the picture, and make sure that the straps or belts used for lifting are strong enough.

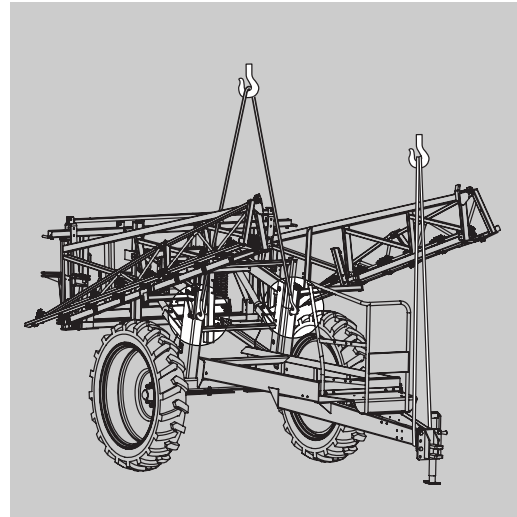

Before putting the sprayer into operation

Although the sprayer has been applied with a strong and protective surface treatment on steel parts, bolts etc. in the factory, it is recommended to apply a film of anticorrosion oil (e.g. CASTROL RUSTILLO or SHELL ENSIS FLUID) on all metal parts in order to avoid chemicals and fertilizers discoloring the enamel. If this is done before the sprayer is put into operation for the first time, it will always be easy to clean the sprayer and keep the enamel clean for many years. This treatment should be carried out every time the protection film is washed off

Support jack

The support jack is stored in retracted position and secured by the linch pin when the sprayer is attached to the tractor.

To retract the support jack: Lift the jack, then pull the linch pin out and rotate the support jack into storage position. Replace linch pin to secure.

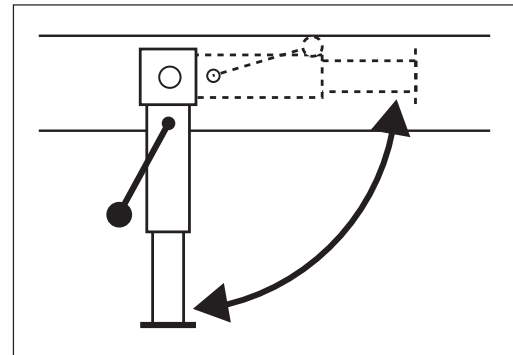

4 - Sprayer setup

Mechanical connections

Hitch - Height adjustment

Adjusting the height of the hitch is obtained by removing the four bolts (A) and raising or lowering the hitch. Inverting the hitch will allow for a greater adjustment to suit tractor drawbar height and to keep the sprayer tank level.

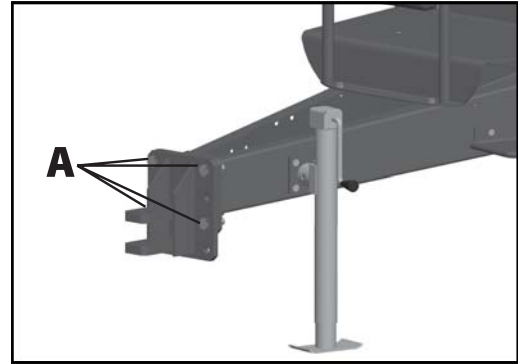

Transmission shaft - Operator's safety

1. Always STOP ENGINE before attaching the transmission shaft to tractor P.T.O. - most tractor P.T.O. shafts can be rotated by hand to facilitate spline alignment, when engine is stopped.
2. When attaching the shaft, make sure that the snap lock is FULLY ENGAGED - push and pull shaft until it locks.
3. Always keep protection guards and chains intact and make sure that it covers all rotating parts, including CV-joints at each end of the shaft. Do not use without protection guard.
4. Do not touch or stand on the transmission shaft when it is rotating - safety distance: 5' (1.5 meter).
5. Prevent protection guards from rotating by attaching the chains allowing sufficient slack for turns.
6. Make sure that protection guards around tractor P.T.O. and implement shaft are intact.
7. Always STOP ENGINE and remove the ignition key before carrying out maintenance or repairs to the transmission shaft or implement.



DANGER! ROTATING TRANSMISSION SHAFTS WITHOUT PROTECTION GUARDS ARE FATAL.

Transmission shaft - Installation

First installation of the transmission shaft is done in the following way:

1. Attach sprayer to tractor and set sprayer height in the position with shortest distance between the tractor and sprayer pump P.T.O. shafts.
2. Stop engine and remove ignition key.
3. If transmission shaft must be shortened, the shaft is pulled apart. Fit the two shaft parts at tractor and sprayer pump and measure how much it is necessary to shorten the shaft. Mark the protection guards.

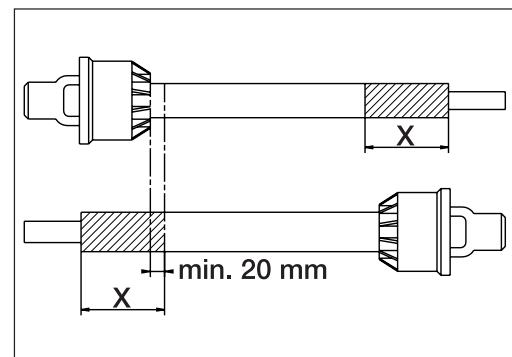

WARNING! The shaft must always have a minimum overlap. The size of this overlap depends on the pump model.

4 - Sprayer setup

Pump with 6 splines/540 r.p.m.

The shaft must always have an overlap (A) of minimum 1/3 of the length.

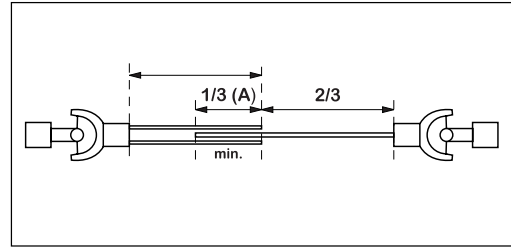

Pump with 21 splines/1000 r.p.m.

The shaft must always have an overlap (A) of minimum 2/3 of the length.

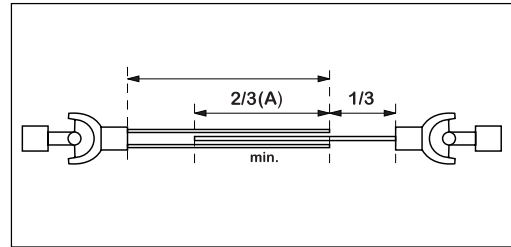

4. The two parts are shortened equally. Use a saw, and file the profiles afterwards to remove burrs.
5. Grease the profiles and assemble male and female parts again.
6. Fit the shaft to tractor P.T.O. and sprayer pump shaft.



ATTENTION! Female part marked with a tractor towards tractor!

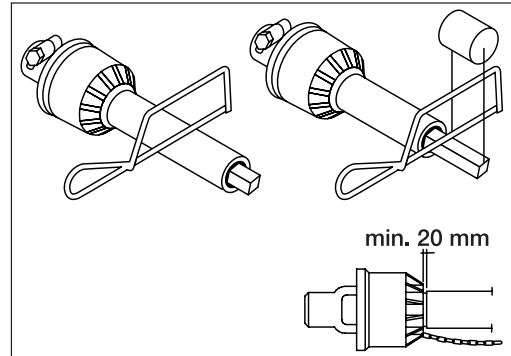

7. Fit the chains to prevent the protection guards from rotating with the shaft.

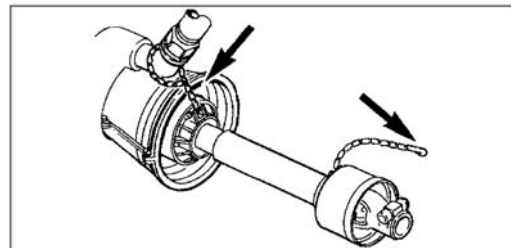

8. To ensure long life of the transmission shaft, try to avoid working angles greater than 15°.

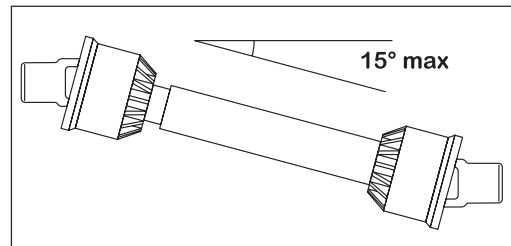

4 - Sprayer setup

Hydraulic systems

General info

Ensure that snap couplers are clean before connection!

After having operated the boom and the system has been filled with oil, check tractor's hydraulic oil level and top up if necessary.



DANGER! Test of the hydraulic system should be done very cautiously. There may be air trapped in the system which can cause violent movements of the boom.



DANGER! Hydraulic leaks: Never use your fingers to locate a leakage in any part of the hydraulic system. Due to high pressure, hydraulic oil may penetrate the skin.

Requirements - tractor (SPB-HY & SPB-HZ)

Connection requirements are:

- One single acting hydraulic outlet for the lift function of the spray boom.
- Two double acting hydraulic outlets for the folding function of the sprayer.

Ensure that snap couplers are clean before connection!

The hydraulic system requires an oil flow of approximately 0.8 GPM (3 liters) and a minimum pressure of 1,950 PSI (130 bar).



WARNING! Due to the variation in tractor hydraulic systems and capacities, care should be exercised when initially operating the sprayer hydraulic cylinders. It is advisable to adjust the hydraulic flow control down to the minimum rate before operating the system. Adjust/increase the flow control after the system is bled of any air, if necessary.

Electrical connections

Power supply

Power requirement is 12V DC. Note polarity! The wires must be at least 10 awg. (4.0 mm²) to ensure a sufficient power supply. For the operating unit, the tractor circuit should have an 8 Amp fuse. The supplied power connector is standard on most newer tractors. If using a tractor with a different power connector, it is necessary to disassemble connector and attach the wires to the actual tractor connector.

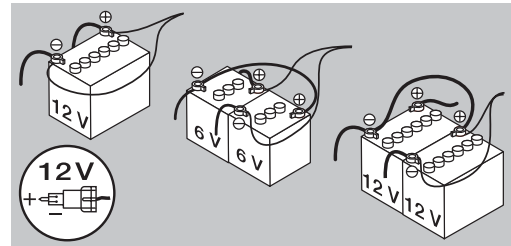

Control boxes

Control boxes are fitted in the tractor cabin at a convenient place.



Installation of control unit brackets

The supplied tractor pillar bracket (A) has a hole spacing of 3.9 in. (100mm) and 4.7 in. (120mm). Check tractor instructions manual for information regarding attachment points.

Three tubes (B) are supplied. One, two or all 3 may be used. They can be bent and shortened. A spacer (C) is also supplied to allow further attachment possibilities. Find the best solution for your tractor or vehicle.

Tube (B) plate is staggered, so if correctly orientated, all boxes will line up.

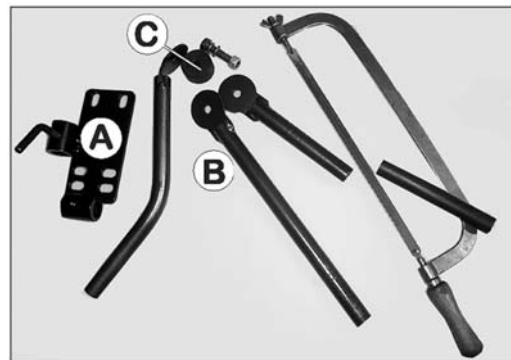

4 - Sprayer setup

Installation of 'D.H.' control unit - Hydraulics (HZ only)

Installation of control box is done as follows:

1. Connect the plug (A) to the tractor's 12V power system. Try to hook-up the handle as close as possible to the battery power supply. HARDI® recommends using an electric distribution box (ref. no. 817925) to ensure a good power supply to various 12V attachments.

Note the polarity to be used:

BROWN wire = Positive (+)

BLUE wire = Negative (-)

2. Route the cable, with the 7 pins, from the hydraulic mount plate to the tractor.

3. Mount the hydraulic control box (B) in a suitable location in the tractor cabin.

4. Connect the female 7 pin plug (C) from the switch box to the 7 pin male plug (D) from the sprayer.

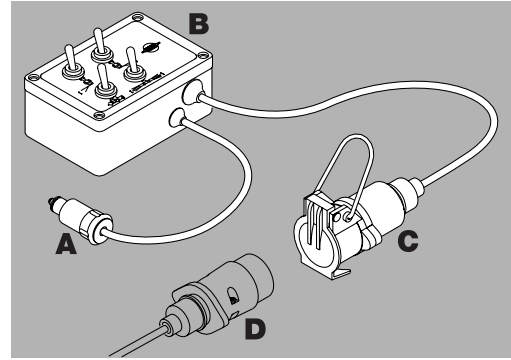

ATTENTION! Check with your dealer or tractor operator's manual for the best location to hook up the 12V system.

Installation of joystick handle - Hydraulics (HZ only)

Installation of handle is done as follows:

1. Attach the control handle/joystick (A) to the hydraulic lever that operates the double acting outlet to be used. The universal mounting bracket (B) is very flexible and a number of different mounting positions can be used.

2. Connect the plug (C) to the tractor's 12V power system. Try to hook-up the handle as close as possible to the battery power supply. HARDI® recommends using an electric distribution box (ref. no. 817925) to ensure a good power supply to various 12V attachments.

Note polarity:

BROWN wire = Positive (+)

BLUE wire = Negative (-)

3. Connect electric plug (D) from sprayer's hydraulics to plug (E) on handle.

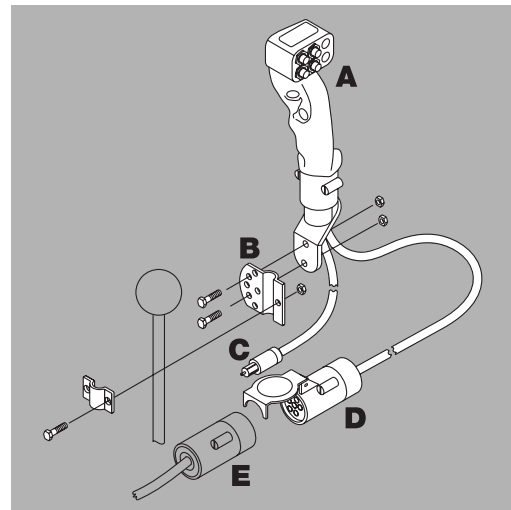

ATTENTION! Check with your dealer or tractor operator's manual for the best location to hook up the 12V system.

4 - Sprayer setup

Installation of control box - EVC control unit

Find a suitable place in the tractor's cabin. Best recommended placement is to the right of the driver seat and in combination with the Hydraulics control unit. It should be secured from movement.



ATTENTION! Tractor driver's seat is the intended working place during operation.



Road safety kit

Connect plug for rear lights to the tractor's 7-pin socket, and check function of rear lights, stop lights and direction indicators on both sides before driving.

The wiring is in accordance with ISO 1724. See section in "Technical specifications".

4 - Sprayer setup

Track width, axles and wheels

Altering the track width

The track width of the RANGER can be adjusted from 60" to 90" in 2" increments as follows:

1. Measure the current track width (center RH tire to center LH tire). Each side must be extended or retracted half the desired alteration.
2. Attach the sprayer to tractor and engage tractor parking brake.
3. Place stop wedges in front of, and behind RH wheel. Jack up frame behind LH wheel, support and secure sprayer body.
4. Remove bolts (A) for LH axle insert.
5. Extend or retract the axle.
6. Replace bolts (A) and tighten to specified torque.
7. Repeat the procedure on RH wheel.
8. Check if the distance from center tire to center of rear frame is equal at RH and LH.
9. Retighten bolts and wheel bolts to specified torque after 8 hours of work.

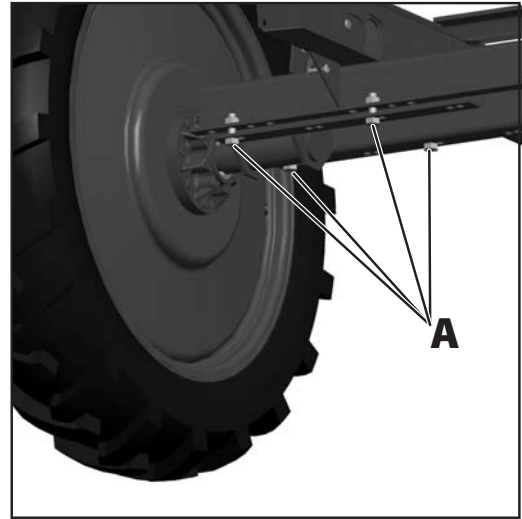

WARNING! Securely support the sprayer during axle adjustments. Never attempt to adjust axles with liquid in the tank. Always block wheels on opposite side when adjusting axles.

Turning rim and rim plate

Track width cannot be altered by turning rim and rim plate. The rim plate can be fitted left or right. With an offset of :

- + 6"
- 5.5"



Boom

Safety info

The boom must not be folded/unfolded while driving! Never use the folding/unfolding functions before sprayer has been stopped! Failure to do so will cause damage to the boom.



DANGER! Before unfolding the boom, it is important to connect the sprayer to the tractor to prevent overbalancing of the sprayer.



DANGER! When folding or unfolding the boom, make sure that no persons or objects are in the operating area of the boom.



DANGER! Always follow the guidelines listed below when driving in areas with overhead power lines:

Never use the folding/unfolding functions in areas with overhead power lines.

Unintended boom movements can cause contact with overhead power lines.



ATTENTION! A label (ref. no. 10533003) is located on the sprayer's drawbar. This label must be visible to the operator when hooking up the sprayer.

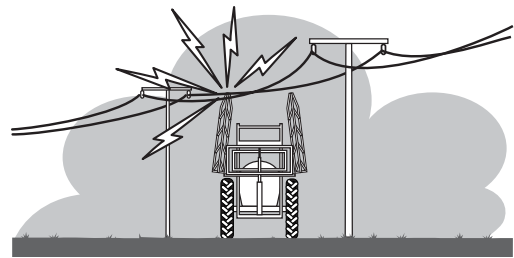

Maneuvering of the boom - HY version

The SPB booms with hydraulic HY-version are operated as follows:

1. Activate the single acting hydraulic outlet to raise the boom and release it from the transport brackets.
2. Activate the double acting hydraulic outlet to unfold the boom. Both wings will now unfold simultaneously.
3. When the boom is completely unfolded, it can be raised or lowered to the desired spray height by activating the single acting hydraulic outlet.
4. Before attempting to fold the boom back into transport position, it must be raised all the way to the top by activating the single acting outlet. This will enable the rear cylinder transport lock.
5. The boom is folded by activating the double acting outlet in the opposite direction that was used to unfold the boom. The boom can now be lowered into the transport brackets.
6. The rear cylinder transport lock will automatically engage when lowering the boom after it has been raised all the way to the top. To disengage the rear transport lock, simply raise the boom back up a few inches and then lower it again.



WARNING! Ensure that the rear cylinder transport lock is properly engaged before transport.



ATTENTION! Only unfold and fold the boom on level ground.

5 - Operation

Maneuvering of the boom - HZ version with Joystick control

The SPB booms with hydraulic HZ-version are operated as follows:

1. Activate the single acting hydraulic outlet to raise the boom and release it from the transport brackets.
2. Depress switches A and B and move hydraulic handle forward or rearward to activate oil flow. Switch positions of the hoses in the double acting remote outlet if you do not like the direction required to activate the boom. Both wings will now unfold simultaneously.
3. "One side folding" will be achieved by following step 2 except that only one of the switches is depressed. See section "Folding one side only".
4. When the boom is completely unfolded, it can be raised or lowered to the desired spray height by activating the single acting hydraulic outlet.
5. Before attempting to fold the boom back into transport position, it must be raised all the way to the top by activating the single acting outlet. This will enable the rear cylinder transport locks.
6. The boom is folded by depressing switches A and B and moving the hydraulic handle in the opposite direction that was used to unfold the boom. The boom can now be lowered into the transport brackets.
7. The rear cylinder transport locks will automatically engage when lowering the boom after it has been raised all the way to the top. To disengage the rear transport lock, simply raise the boom up a few inches and then lower it again.

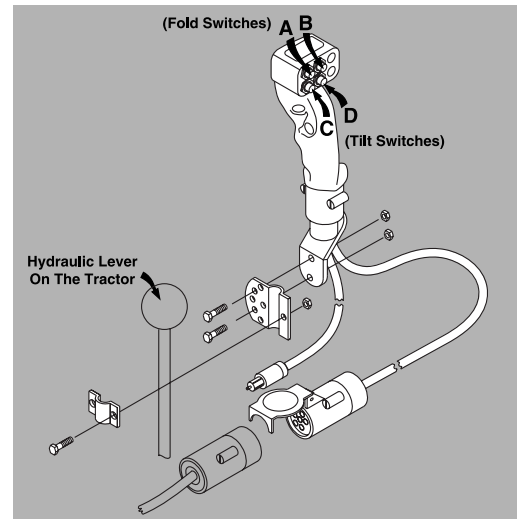

WARNING! Ensure that the rear cylinder transport lock is properly engaged before transport.



ATTENTION! Only unfold and fold the boom on level ground.



WARNING! The folding function (switches A & B) must only be operated when the sprayer is stationary! Failure to do so will damage the boom.



ATTENTION! Boom cannot be operated with tractor's hydraulic levers.

Boom tilt function - Joystick control

The boom is tilted by depressing switches C and D and moving the hydraulic handle forward or rearward to activate oil flow. Switch positions of the hoses in the double acting outlet if you do not like the direction required to activate the boom.



WARNING! Never attempt to fold boom to transport position when wings are tilted. Always let wings down to horizontal position prior to folding.



WARNING! Never attempt to work on or around wing section when tilted up.



WARNING! Unexpected boom movements may occur if wings are tilted when folding.



WARNING! Never use tilt function when boom is folded into transport position.

Maneuvering of the boom - HZ version with 'DH' control

On tractors with 'closed center' hydraulic systems, the SPB booms with hydraulic HZ-version are operated as follows:

1. Activate the single acting hydraulic outlet to raise the boom and release it from the transport brackets.
2. Engage the tractor's double acting remote outlet lever and lock it in the engaged position.
3. Activate switches A and B upwards and hold to unfold both wings simultaneously.
4. "One side folding" will be achieved by following step 3 except that only one of the switches is activated. See section "Folding one side only".
5. When the boom is completely unfolded, it can be raised or lowered to the desired spray height by activating the single acting hydraulic outlet.
6. Before attempting to fold the boom back into transport position, it must be raised all the way to the top by activating the single acting outlet. This will enable the rear cylinder transport locks.
7. The boom is folded by holding switches A and B downwards (with tractor's double acting remote outlet lever still locked in the engaged position). The boom can now be lowered into the transport brackets.
8. The rear cylinder transport locks will automatically engage when lowering the boom after it has been raised all the way to the top. To disengage the rear transport lock, simply raise the boom back up a few inches and then lower it again.

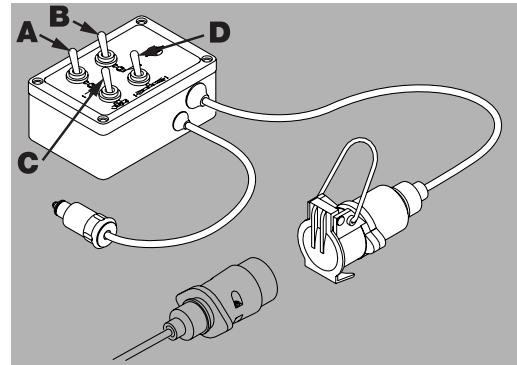

WARNING! Ensure that the rear cylinder transport lock is properly engaged before transport.



ATTENTION! Only unfold and fold the boom on level ground.



WARNING! The folding function (switches A & B) must only be operated when the sprayer is stationary! Failure to do so will damage the boom.



ATTENTION! Boom cannot be operated with tractor's hydraulic levers.

Boom tilt function - 'DH' control

Engage the tractor's double acting remote outlet lever and lock it in the engaged position. Activate switch C upwards and hold to tilt the left hand boom up. (Holding the switch down will tilt the boom down). To tilt the right hand boom, activate switch D.



WARNING! Never attempt to fold boom to transport position when wings are tilted. Always let wings down to horizontal position prior to folding.



WARNING! Never attempt to work on or around wing section when tilted up.



WARNING! Unexpected boom movements may occur if wings are tilted when folding.



WARNING! Never use tilt function when boom is folded into transport position.

5 - Operation

Folding one side only (HZ Hydraulics only)

If only one side of the boom is to be used for spraying, first unfold the boom completely and then turn switches off. Then activate the switch for the side that is to be folded and activate the double acting outlet to fold that side into transport position.



ATTENTION! It is not advisable to go directly from transport position to spray position with one side only. Both wings must first be completely unfolded and then one side folded back in.

Liquid system

Filling of water

Tank should normally be filled 1/3 with water before adding chemicals. Always follow instructions given on the chemical container!

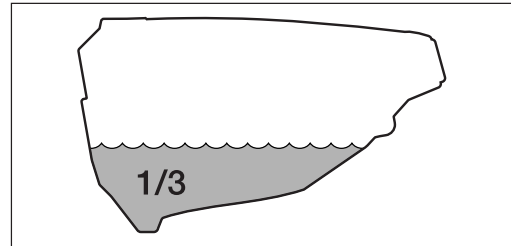

WARNING! If the sprayer is put aside with liquid in the main tank, all MANIFOLD valves must be closed.

Filling through tank lid

Water is filled into the tank by removing the tank lid located at front of sprayer tank which is accessible from platform. It is recommended to use water as clean as possible for spraying purposes. Always fill water through the strainer basket to prevent foreign particles from entering the tank. An overhead tank can be used in order to obtain high filling capacity.

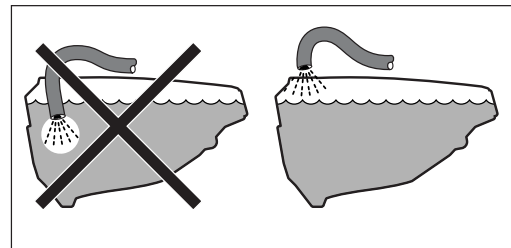

WARNING! Do not let the filling hose enter the tank. Keep it outside the tank, pointing towards the filling hole. If the hose is lowered into the tank and the water pressure drops at the water supply, chemicals may be siphoned back and contaminate the water supply lines and source.

5 - Operation

Suction filling device (optional - main tank only)

The Suction Filling Device is operated as follows:

1. Remove plug from Quick Fill coupler and connect filling hose from water supply.
2. Make sure bottom Suction Manifold valve is turned to "Main Tank".
3. Turn top Pressure Manifold valve to "HARDI® FILLER" if equipped. Otherwise turn to "Spray" with control unit turned "Off".
4. Engage pump and set to operating r.p.m. (540/1000).
5. Turn top Suction Manifold valve towards "Quick Fill" function.
6. Water will be drawn from the water supply. Fill tank to desired level. Keep an eye on the level indicator.
7. Chemicals may be added to the HARDI® FILLER (optional) while using the suction filling device. Follow directions in sections "Filling Liquid chemicals by HARDI® FILLER" or "Filling Powder chemicals by HARDI® FILLER".
8. Turn top Suction Manifold valve "Off" to discontinue filling process. Then disengage pump.
9. Disconnect filling hose and replace Quick Fill plug.

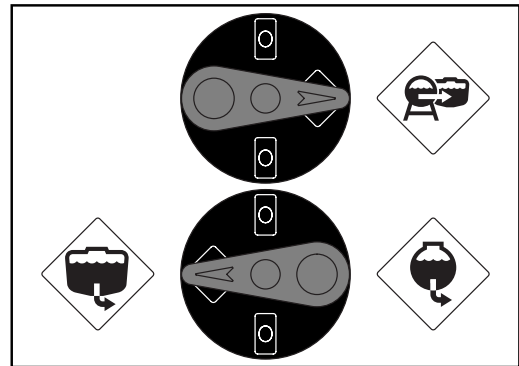
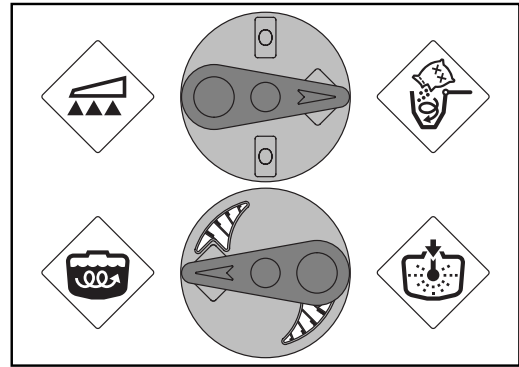

DANGER! Avoid contamination or personal injury. Do not turn suction valve towards "Quick Fill" unless pump is running and filling hose is connected. If this valve is open when the pump is not engaged, liquid can flow out of the valve.



ATTENTION! Observe local legislation regarding use of filling device. In some areas it is prohibited to fill from open water reservoirs (lakes, rivers etc.). It is recommended only to fill from closed reservoirs (mobile water tanks etc.) to avoid contamination.



WARNING! If filling hose/filter is carried on the sprayer during spraying, it can be contaminated by spray drift which will be transferred to water source when filling!



WARNING! Do not leave the sprayer while filling the tank. Keep an eye on the level indicator in order NOT to over-fill the tank.



WARNING! Never turn the bottom suction valve to "Flush Tank" while using the Suction Filling device. The Flush Tank cannot be filled using the pump, and contamination of the Flush Tank could occur if pump isn't engaged.



ATTENTION! For centrifugal pump systems, there must be enough liquid in the main tank to prime the pump before using the suction filling device.



ATTENTION! Once water has started flowing from the water supply, the bottom Suction Manifold valve may be turned off for faster filling, but must be turned back to "Main Tank" before closing the Quick Fill valve.

5 - Operation

Filling of main tank using Quick Fill (optional)

The main tank is filled using the Quick Fill as follows:

1. Turn bottom Suction Manifold valve to "Main Tank".
2. Remove plug from Quick Fill coupler and connect filling hose from water supply (i.e. overhead fill tank).
3. Turn water supply "On" (so filling hose is pressurized).
4. Turn top Suction Manifold valve towards "Quick Fill" function.
5. Fill tank to desired level. Keep an eye on the level indicator.
6. Turn top Suction Manifold valve "Off" to discontinue filling process.
7. Turn water supply "Off" and remove the filling hose.
8. Replace Quick Fill plug.

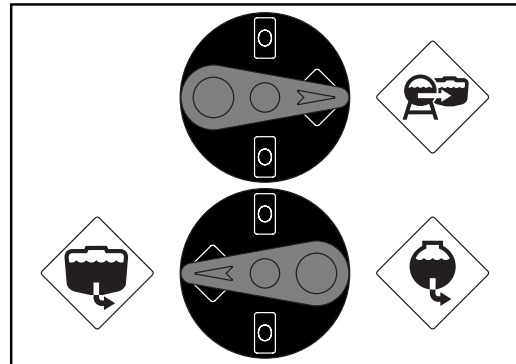

DANGER! Avoid contamination or personal injury. Do not turn suction valve to "Quick Fill" unless filling hose is connected. If this valve is open when the pump is not engaged, liquid can flow out of the valve.



WARNING! Do not leave the sprayer while filling the tank. Keep an eye on the level indicator in order NOT to overfill the tank.

Filling of flush tank using Quick Fill (optional)

The flush tank is filled using the Quick Fill as follows:

1. Turn bottom Suction Manifold valve to "Flush Tank".
2. Remove plug from Quick Fill coupler and connect filling hose from water supply (i.e. overhead fill tank).
3. Turn water supply "On" (so filling hose is pressurized).
4. Turn top Suction Manifold valve towards "Quick Fill" function.
5. Fill tank to desired level. Be careful not to overfill.
6. Turn top Suction Manifold valve "Off" to discontinue filling process.
7. Turn water supply "Off" and remove the filling hose.
8. Replace Quick Fill plug.

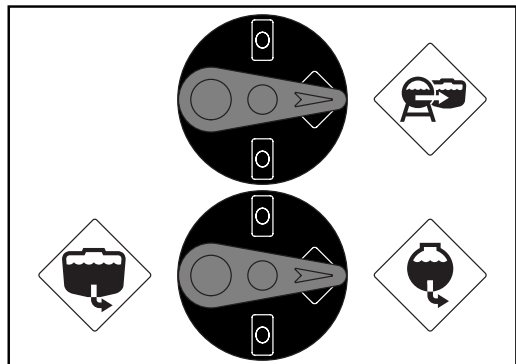

Capacity: 66 gal. (250 liters).

Only fill flush tank with clean water! To avoid algae developing in the flush tank, always drain the flush tank if the sprayer is not in use for a longer period of time.

For cleaning purposes, etc. the flush tank is also accessible via the tank lid on top of tank.



DANGER! Avoid contamination or personal injury. Do not turn suction valve to "Quick Fill" unless filling hose is connected. If this valve is open when the pump is not engaged, liquid can flow out of the valve.



WARNING! Do not leave the sprayer while filling the tank. Keep an eye on the tank in order NOT to overfill.

5 - Operation

Filling of clean water tank

A clean water tank is integrated into the front left corner of the main tank (behind the MANIFOLD system). It is accessed for filling at the sprayer's left side when entering the platform. Remove tank lid, fill with clean water and replace tank lid.

For use of water, turn the ball valve lever to open tap. The ball valve is located at the bottom of the clean water tank on sprayer's left side. The water from this tank is for hand washing, cleaning of clogged nozzles, etc. Only fill the clean water tank with clean water.

Capacity: 4.8 gal. (18 liters).



WARNING! Although the clean water tank is only filled with clean water, this water must never be used for drinking.

Adjustment of EVC operating unit

Before spraying, adjust the EVC operating unit using clean water (without chemicals).

1. Choose the correct nozzle for the spray job by turning the TRIPLET nozzle bodies. Make sure that all nozzles are the same type and capacity. See the "Spray Technique" book.
2. Make sure all distribution valves (A) are turned on.
3. Set pressure regulation valve to minimum pressure (activate pressure regulation switch "down" until emergency handle stops rotating).
4. Put the tractor in neutral and adjust the P.T.O. revolutions to the number of revolutions that will typically be used while spraying. Remember the number of revolutions on the P.T.O. must be kept between 300-600 r.p.m. (540 r.p.m. pump) or 650-1100 rpm (1000 r.p.m. pump).
5. Activate pressure regulation switch "up" until the required spraying pressure is shown on the pressure gauge.

Adjustment of pressure equalization:

1. Disconnect power to the control box to allow for manual operation of the boom distribution valves. Adjustments will be made one section at a time until all valves have been adjusted.
2. Note the pressure on the pressure gauge. This reading will be used throughout the adjustment.
3. Manually close one of the distribution valves by turning the green handle (A).
4. Turn the adjusting screw (B), under the valve just closed, until the pressure gauge again shows the same pressure as before (clockwise for higher pressure, counterclockwise for lower pressure).
5. Turn the distribution valve (A) back on.
6. Adjust the other sections of the distribution valve in the same way.

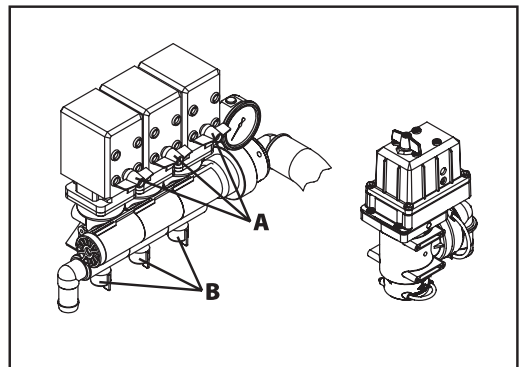

ATTENTION! HEREAFTER ADJUSTMENT OF PRESSURE EQUALIZATION WILL ONLY BE NEEDED WHEN:

1. YOU CHANGE TO NOZZLES WITH OTHER CAPACITIES
2. THE NOZZLE OUTPUT INCREASES AS THE NOZZLES WEAR

Safety precautions - crop protection chemicals



Always be careful when working with crop protection chemicals!



WARNING! Always wear correct protective clothing before handling chemicals!

Personal protection

Depending on chemical type, protective gear /equipment should be worn to avoid contact with the chemicals, e.g.:

- Gloves
- Waterproof boots
- Headgear
- Respirator
- Safety goggles
- Chemical resistant overall



WARNING! Protective clothing/equipment should be used when preparing the spray liquid, during the spray job and when cleaning the sprayer. Follow the chemical manufacturer's instructions given on the chemical label.



WARNING! It is always advisable to have clean water available, especially when filling the sprayer with the chemical.



WARNING! Always clean the sprayer carefully and immediately after use.



WARNING! Only mix chemicals in the tank according to directions given by the chemical manufacturer.



WARNING! Always clean the sprayer before changing to another chemical.

5 - Operation

Filling chemicals through tank lid

The chemicals are filled through the tank lid - Note instructions on the chemical container!



WARNING! Be careful not to slip or splash chemicals when carrying chemicals up to the tank lid!

1. Make sure the control unit is switched off.
2. Turn the bottom Suction Manifold valve handle towards "Suction from main tank". Turn the top Pressure Manifold valve handle towards "Spray" and the bottom Pressure Manifold valve towards "Agitation".
3. Engage pump and set to operating r.p.m. (540/1000).
4. Add the chemicals through the main tank hole.
5. When the spray liquid is well mixed, keep P.T.O. engaged so the spray liquid is continuously agitated until it has been sprayed on the crop.

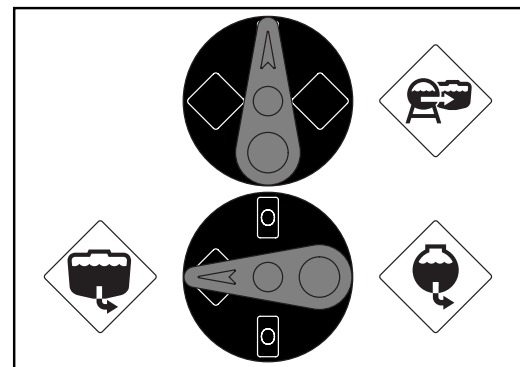
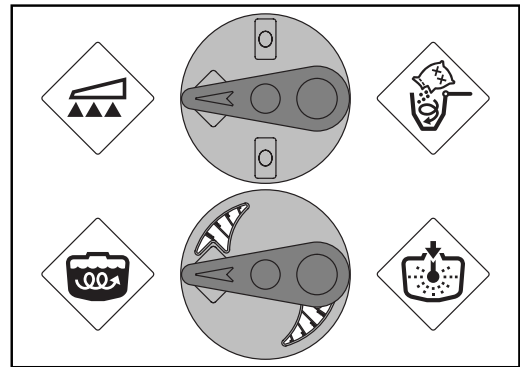

Filling Liquid chemicals by HARDI® FILLER

1. Fill the main tank at least 1/3 with water (unless something else is stated on the chemical container label). See section "Filling of water".
2. Turn the handle at the bottom Suction Manifold towards "Main tank". Turn top Pressure Manifold valve towards "HARDI® FILLER" and the bottom Pressure Manifold valve towards "Agitation". Close remaining valves.
3. Check that bottom valve (A) at the FILLER is closed.
4. Engage pump and set to operating r.p.m. (540/1000).
5. Open FILLER lid.
6. Measure the correct quantity of chemical and fill it into the hopper.
7. Open the bottom valve (A) and the chemical is transferred to the main tank.
8. If the chemical container is empty, it can be rinsed by the container rinsing device (if fitted). Place the container over the multi-hole nozzle and press the lever (B).
9. Engage the hopper rinsing device by opening valve (C).
10. Close valve (C) when the hopper is rinsed.
11. Close valve (A) and the FILLER lid.
12. When the spray liquid is well mixed, turn top Pressure Manifold valve towards "Spraying" position. Keep P.T.O. engaged so the spray liquid is continuously agitated until it has been sprayed on the crop.

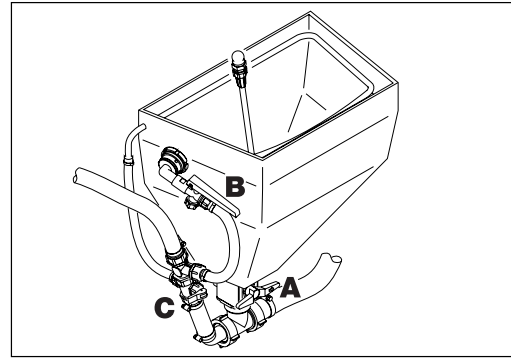

ATTENTION! The scale in the hopper can only be used if the sprayer is parked at level ground! It is recommended to use a measuring jug for best accuracy.



DANGER! Do not press lever unless the multi-hole nozzle is covered by a container to avoid spray liquid hitting the operator.



ATTENTION! Rinsing device uses spray liquid to rinse containers for concentrated chemicals. Always rinse the chemical containers with clean water several times until they are clean before disposal.



ATTENTION! The hopper rinsing device is using spray liquid for rinsing the hopper for concentrated chemical! The FILLER must always be cleaned together with the rest of the sprayer when the spray job is done.

5 - Operation

Filling Powder chemicals by HARDI® FILLER

1. Fill the main tank at least 1/2 with water (unless something else is stated on the chemical container label). See section "Filling of water".
2. Turn the handle at the bottom Suction Manifold towards "Main tank". Turn top Pressure Manifold valve towards "HARDI® FILLER" and the bottom Pressure Manifold valve towards "Agitation".
3. Engage pump and set to operating r.p.m. (540/1000).
4. Open the bottom valve (A) at the FILLER. Open FILLER lid.
5. Engage the hopper rinsing device by opening valve (C).
6. Measure the correct quantity of chemical and sprinkle it into the hopper as fast as the rinsing device can flush it down.
7. If the chemical container is empty it can be rinsed by the container rinsing device (if fitted). Fit the bag bracket and place the powder bag over the multi-hole nozzle and press the lever (B).
8. Close valve (C) when the hopper is rinsed.
9. Close valve (A) and the FILLER lid.
10. When the spray liquid is well mixed, turn top Pressure Manifold valve towards "Spraying" position. Keep P.T.O. engaged so the spray liquid is continuously agitated until it has been sprayed on the crop.

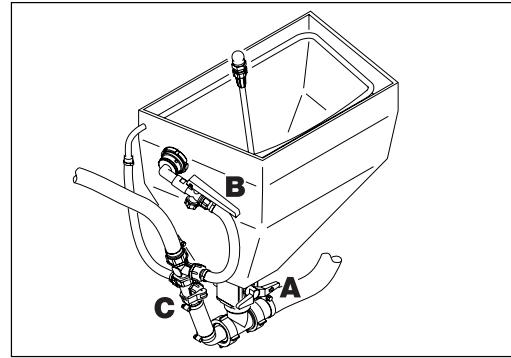

DANGER! Do not press lever unless the multi-hole nozzle is covered by a container to avoid spray liquid hitting the operator.



ATTENTION! Rinsing device uses spray liquid to rinse containers for concentrated chemicals. Always rinse the chemical containers with clean water several times until they are clean before disposal.



ATTENTION! The hopper rinsing device is using spray liquid for rinsing the hopper for concentrated chemical! The FILLER must always be cleaned together with the rest of the sprayer when the spray job is done.



ATTENTION! The scale in the hopper can only be used if the sprayer is parked at level ground! It is recommended to use a measuring jug for best accuracy.

5 - Operation

Agitation before re-starting spraying

If a spraying job has been interrupted for a while, severe sedimentation can occur depending on chemicals being used. When re-starting spray job, it might be necessary to agitate sedimented material first.

1. Make sure the control unit is switched off.
2. Turn the bottom Suction Manifold valve handle towards "Suction from main tank". Turn the top Pressure Manifold valve handle towards "Spray" and the bottom Pressure Manifold valve towards "Agitation".
3. Engage pump and set to operating r.p.m. (540/1000).
4. Agitation will start and should be continued for at least 10 minutes.
5. Once the chemicals are mixed, spraying can resume.

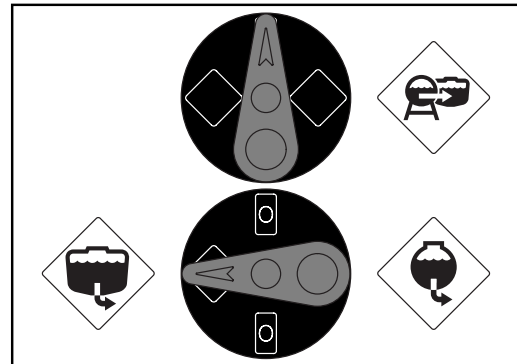
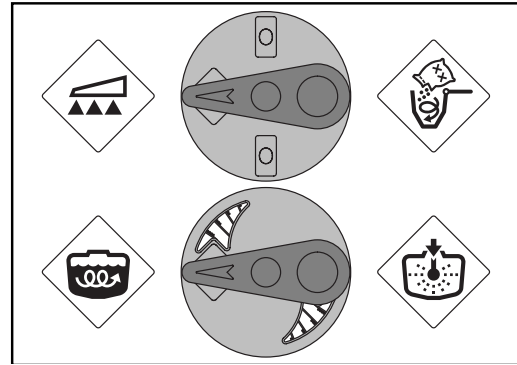

Operating the control unit while spraying

The switches on the spray control box control the following functions:

1. Power switch
2. Manual pressure regulation
3. Main ON/OFF
4. End nozzle (Left/OFF/Right)*
5. Foam marker regulation*
6. Foam marker (Left/OFF/Right)*
7. Boom section valves
8. Valve function A-B*

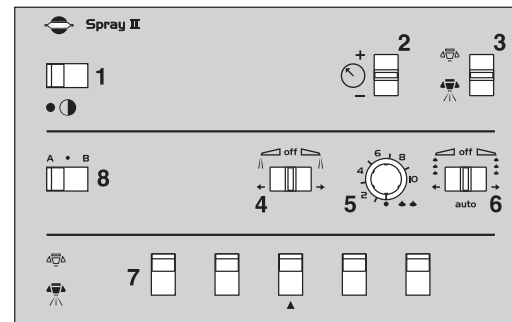

*optional equipment

In order to close the entire boom, switch ON/OFF (3) to OFF position. This returns the pump output to the tank through the return system. The diaphragm Non-drip valves ensure instantaneous closing of all nozzles.

In order to close one or more sections of the boom, switch the relevant distribution valve (7) to off position. The pressure equalization ensures that the pressure does not rise in the sections which are to remain open.

On the sprayer, the bottom Suction Manifold valve should be turned toward "Suction from Main tank". The top Pressure Manifold valve should be turned toward "Spraying" and the bottom Pressure Manifold valve to "Agitation" if necessary.

5 - Operation

Quick reference - Operation

In the following diagram, valve positions for different options are described.

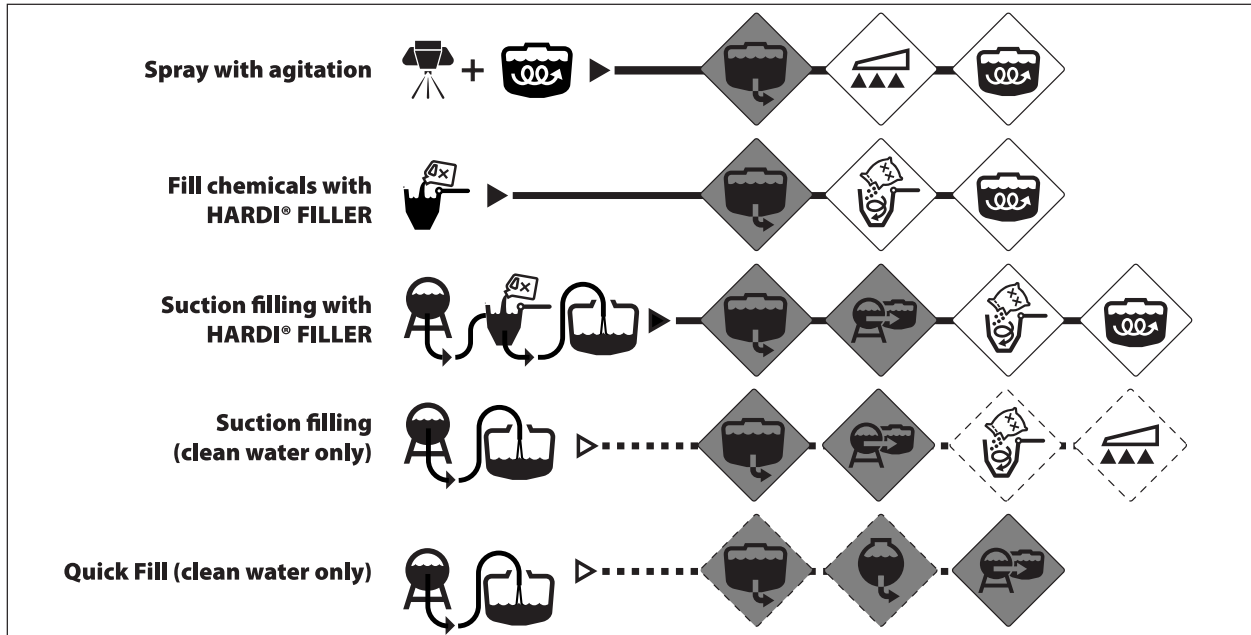

Cleaning

General info

In order to derive full benefit from the sprayer for many years the following service and maintenance program should be followed.



ATTENTION! Always read the individual paragraphs. Read instructions for service/maintenance jobs carefully before starting on the job. If any portion remains unclear or requires facilities which are not available, then for safety reasons please leave the job to your HARDI® dealer's workshop.



ATTENTION!

Clean sprayers are safe sprayers.

Clean sprayers are ready for action.

Clean sprayers cannot be damaged by pesticides and their solvents.

Guidelines

1. Read the whole chemical label. Take note of any particular instructions regarding recommended protective clothing, deactivating agents, etc. Read the detergent and deactivating agent labels. If cleaning procedures are given, follow them closely.
2. Be familiar with local legislation regarding disposal of pesticides washings, mandatory decontamination methods, etc. Contact the appropriate department, e.g. Dept. of Agriculture.
3. Pesticide washings can usually be sprayed out on a soakaway. This is an area of ground that is not used for cropping. You must avoid seepage or runoff of residue into streams, water courses, ditches, wells, springs, etc. The washings from the cleaning area must not enter sewers. Drainage must lead to an approved soakaway.
4. Cleaning starts with the calibration, as a well calibrated sprayer will ensure the minimal amount of remaining spray liquid.
5. It is good practice to clean the sprayer immediately after use and thereby render the sprayer safe and ready for the next pesticide application. This also prolongs the life of the components.
6. It is sometimes necessary to leave spray liquid in the tank for short periods, e.g. overnight, or until the weather becomes suitable for spraying again. Unauthorized persons and animals must not have access to the sprayer under these circumstances.
7. If the product applied is corrosive, it is recommended to coat all metal parts of the sprayer before and after use with a suitable rust inhibitor.

5 - Operation

Cleaning the tank and liquid system

1. Dilute remaining spray liquid in the tank with at least 10 parts of water and spray the liquid out in the field you have just sprayed.
2. Select and use the appropriate protective clothing. Select detergent suitable for cleaning and suitable deactivating agents if necessary.
3. Rinse and clean sprayer and tractor externally. Use detergent if necessary.
4. Remove tank and suction filters and clean. Be careful not to damage the mesh. Replace suction filter top. Replace filters when the sprayer is completely clean.
5. With the pump running, rinse the inside of the tank. Remember the tank roof. Rinse and operate all components and any equipment that has been in contact with the chemical. Before opening the distribution valves and spraying the liquid out, decide whether this should be done in the field again or on the soakaway.
6. After spraying the liquid out, stop the pump and fill at least 1/5 of the tank with clean water. Note that some chemicals require the tank to be completely filled. Add appropriate detergent and/or deactivating agent, e.g. washing soda or Triple ammonia.
7. Start the pump and operate all controls enabling the liquid to come in contact with all the components. Leave the distribution valves until last. Some detergents and deactivating agents work best if left in the tank for a short period. Check the label. The Cyclone filter can be flushed by engaging the lever in the bottom to flush position. Stop the pump and remove the hose. Start the pump for a few seconds to flush filter. Be careful not to lose the restrictor nozzle.
8. Drain the tank and let the pump run dry. Rinse inside of the tank, again letting the pump run dry.



ATTENTION! If the sprayer is equipped with a centrifugal pump, do not run pump dry for longer than 3 seconds. Otherwise severe damage to the pump will occur.

9. Stop the pump. If the pesticides used have a tendency to block nozzles and filters, remove and clean them immediately.
10. Replace all the filters and nozzles and store the sprayer. If, from previous experiences, it is noted that the solvents in the pesticide are particularly aggressive, store the sprayer with the tank lid open.



ATTENTION! It is advisable to increase the forward speed (double if possible) and reduce the pressure to 20 psi (1.5 bar) when spraying diluted remaining liquid in the field just sprayed.



ATTENTION! If a cleaning procedure is given on the chemical label, follow it closely.



ATTENTION! If the sprayer is cleaned with a high pressure cleaner, lubrication of the entire machine is recommended.

Cleaning and maintenance of filters

Clean filters ensure:

- Sprayer components such as valves, diaphragms and operating unit are not hindered or damaged during operation.
- Nozzle blockages do not occur while spraying.
- Long life of the pump. A blocked suction filter will result in pump cavitation. The main filter protecting sprayer components is the suction filter. Check it regularly.

Use of flush tank and rinsing nozzles

The incorporated flush tank can be used for two different purposes.

A. In-field diluting of remaining spray liquid residue in the spraying circuit for spraying the liquid in the field, before cleaning the sprayer. This cleaning procedure is divided in two main steps:

Cleaning of the liquid system:

1. Empty the sprayer as much as possible. Close the bottom Pressure Manifold valve (no agitation) and spray till air comes out of all nozzles.
2. Turn Suction Manifold valve towards "Flush tank" and top Pressure Manifold valve to "Spray" with control unit turned "Off"
3. Engage and set the pump at approximately 300 r.p.m.
4. When 1/2 of content in flush tank is used, turn Suction valve towards "Main tank" and operate all valves on the pressure side of the system, so all hoses and components are rinsed. If equipped with HARDI® FILLER, open bottom valve, engage the hopper rinsing device and close it again when clean water comes out. With HARDI® FILLER lid closed, squeeze Chemical Container Cleaning lever to clean the hopper. Open HARDI® FILLER lid and open the bottom valve again until the hopper is empty. When empty, close the HARDI® FILLER bottom valve.
5. Turn the top Pressure Manifold Valve towards "Spray" and spray liquid in the field you have just sprayed.

Cleaning of Main tank:

6. Turn the Suction valve towards "Flush tank" and bottom Pressure valve towards "Tank Rinsing".
7. When another 1/4 of contents in flush tank are used, then turn Suction valve towards "suction from Main tank" and bottom Pressure valve "Off" (no agitation).
8. Turn top Pressure valve towards "Spray" and spray liquid in the field you have just sprayed.
9. Repeat steps 6 - 8 one more time.

B. Flushing the pump, operating unit, spray lines, etc. in case of stop in spraying before main tank is empty (e.g. beginning rain etc.).

Cleaning of the liquid system before main tank is empty:

1. Turn Suction valve towards "Flush tank" and top Pressure valve towards "Spraying" position.
2. Close bottom Pressure valve (no agitation).
3. Close return valve on Cyclone filter (if fitted) to prevent clean water from diluting tank contents.
4. Make sure control unit is switched "On" with all distribution valves open (boom spraying position).
5. Engage the pump and spray water from Flush tank in the field until all nozzle tubes/nozzles are flushed with clean water.
6. Disengage pump again.



ATTENTION! The rinsing nozzles cannot always guarantee a 100% cleaning of the tank. Always clean manually with a brush afterwards, especially if crops sensitive to the chemical just sprayed are going to be sprayed afterwards!



ATTENTION! It is advisable to increase the forward speed (double if possible) and reduce the pressure to 20 psi (1.5 bar).



ATTENTION! If a cleaning procedure is given on the chemical label, follow it closely.



ATTENTION! When flushing the pump before main tank is empty (B - above), make sure all distribution valves are open, agitation is "Off" and Cyclone filter return is "Off" whenever the pump is running to prevent clean water from returning to the tank and diluting the contents.



ATTENTION! If the sprayer is cleaned with a high pressure cleaner, lubrication of the entire machine is recommended.

5 - Operation

Quick reference - Cleaning

In the following diagram, valve positions for different options are described.

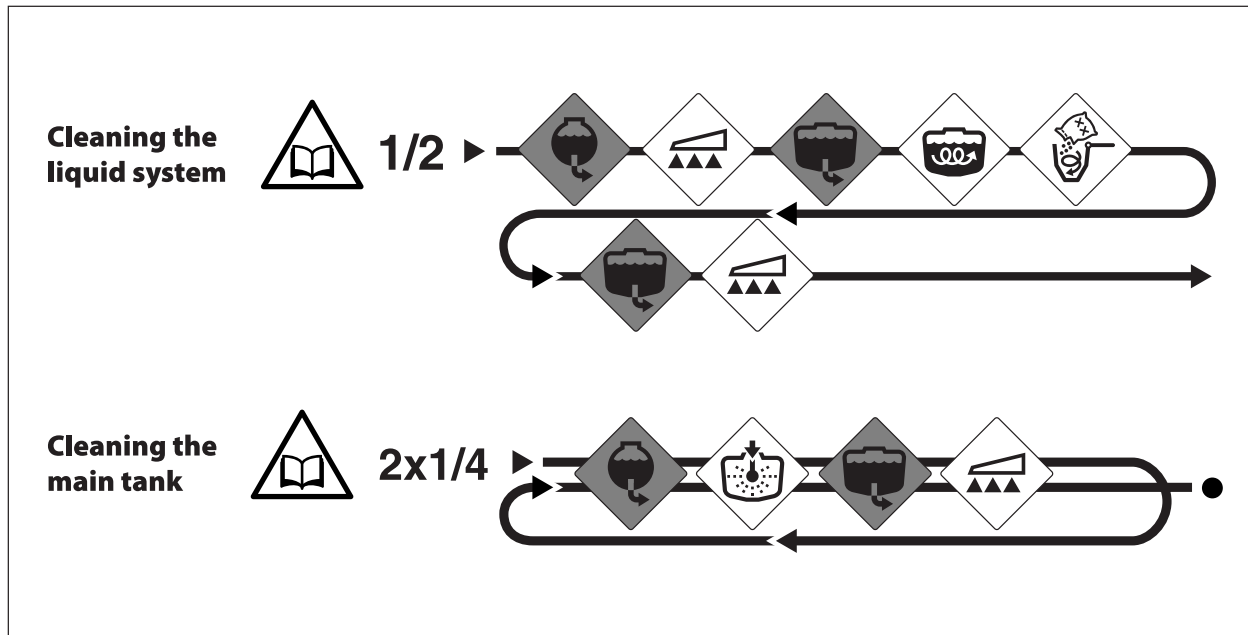

Technical residue

Inevitably a quantity of spray liquid will remain in the system. It cannot be sprayed properly on the crop, as the pump takes in air when the tank is about to be empty.

This Technical Residue is defined as the remaining liquid quantity in the system as the first clear pressure drop on the pressure gauge is read.

The residues in the tank should be diluted immediately in the relationship 1:10 with clean water and sprayed onto the crop just sprayed before cleaning the sprayer.

Using the drain valve

The drain valve is located and operated from the left hand side of the sprayer near the boom transport bracket. Pull the string to open the drain valve. The valve is spring-loaded, but can be kept open by pulling the string upwards in the V-shaped slit. To release, pull the string downward and the valve will close automatically.

If draining residues, e.g. liquid fertilizer into a reservoir, a snap-coupler with hose can rapidly be connected to the drain valve and the liquid safely drained.

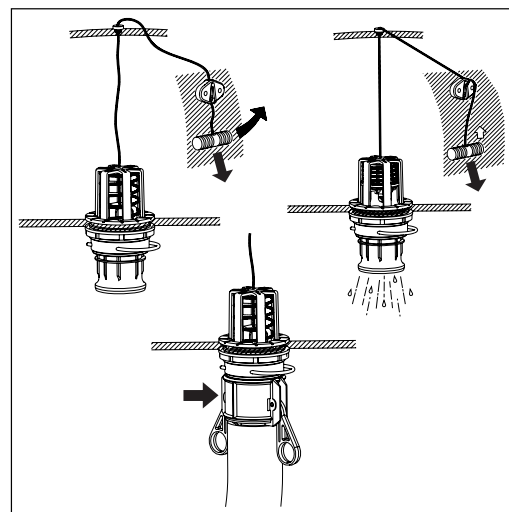

Spray Technique - see separate book.
Optional extras - see separate books.

Lubrication

General info

Always store lubricants clean, dry and cool - preferably at a constant temperature - to avoid contamination from dirt and condensed water. Keep oil filling jugs, hoppers and grease guns clean, and clean the lubricating points thoroughly before lubricating. Avoid skin contact with oil products for longer periods.

Always follow the shown direction concerning recommended quantity. If no recommended quantity is given, feed lubricator until new grease becomes visible.

Pictograms in lubrication & oiling plans tell the following:

1. Lubricant to be used (see "Recommended lubricants").
2. Operating hours before next lubrication.

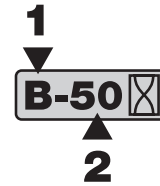

ATTENTION! If the sprayer is cleaned with a high pressure cleaner, lubrication of the entire machine is recommended.

Recommended lubricants



A BALL BEARINGS:
Universal Lithium grease, NLGI No. 2
SHELL RETINAX EP2
CASTROL LMX GREASE



B SLIDE BEARINGS:
Lithium grease with
Molybdenumdisulphide or graphite
SHELL RETINAX HDM2
CASTROL MOLYMAX



C OIL LUB. POINTS:
TOTAL Transmission TM
SAE 80W/90
Castrol EPX 80W/90
SHELL Spirax 80W/90
Mobil Mobilube 80W/90

Boom lubrication & oiling plan

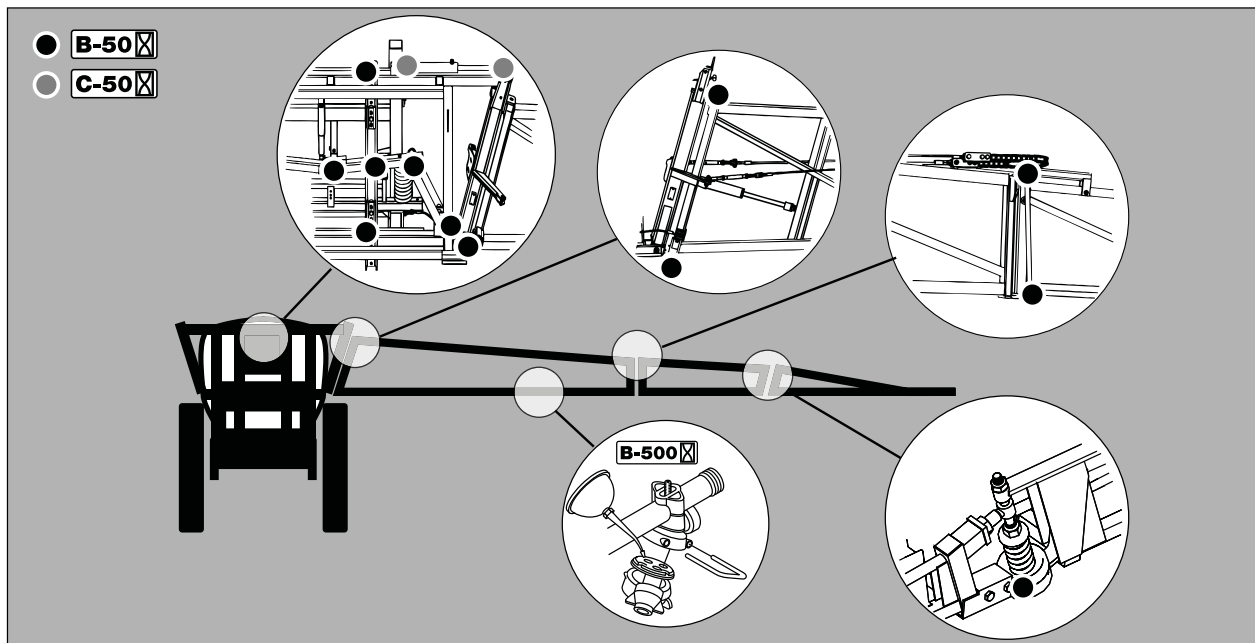

6 - Maintenance

Trailer lubrication & oiling plan

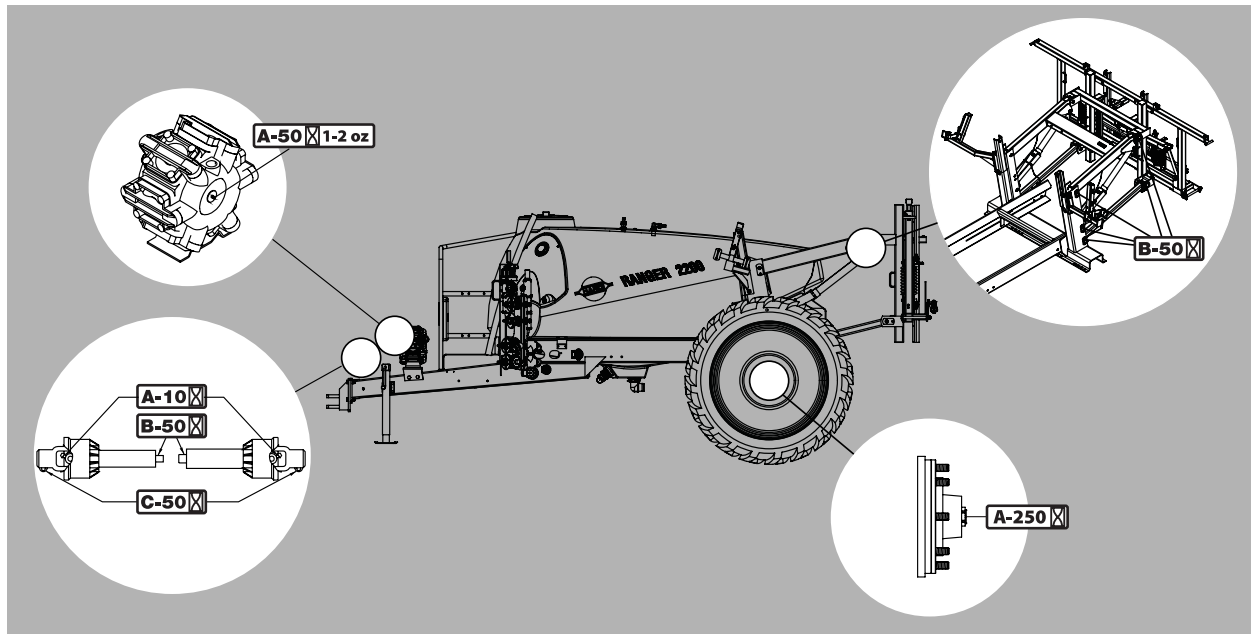

Service and Maintenance intervals

10 hours service - Suction filter

To service the suction filter:

1. Pull out the steel clip (A).
2. Lift the suction hose fitting (B) from housing.
3. Filter guide and filter (C) can now be removed.

To reassemble:

4. Press the guide onto filter end.
5. Place the filter into housing with guide facing up.
6. Ensure the O-ring (D) on the hose fitting is in good condition and lubricated.
7. Refit the suction hose (B) and steel clip (A).

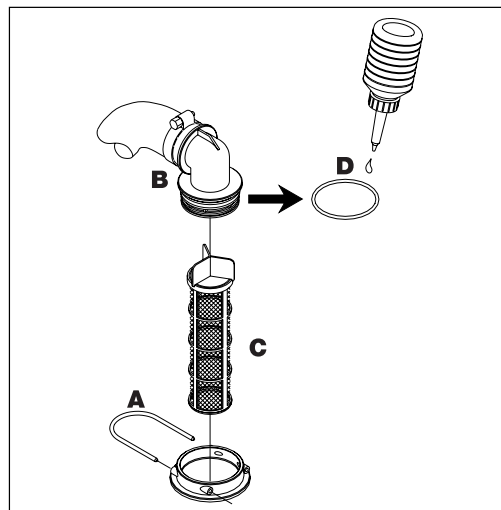

10 hours service - Cyclone filter

To service the Cyclone filter:

1. Turn top Pressure Manifold valve "Off".
2. Unscrew filter lid (A).
3. Lift the lid and filter (B) from housing.
4. Separate filter from the integrated filter guide in the lid and clean the filter.

To reassemble:

1. Grease the two O-rings on the lid/filter guide. Due to small space at lid for example use a brush to grease with.
2. Mount the filter onto the recess (which may not be greased) in the lid/filter guide.
3. Place the filter/filter lid into housing and screw the lid until it hits the stop.



DANGER! Top Pressure Manifold valve must always be turned to the unused position before opening the Cyclone filter! If not, then spraying liquid can hit you when opening the filter and drain from the tank!



6 - Maintenance

10 hours service - In-Line filter (optional equipment)

If the boom is equipped with In-Line Filters unscrew the filter bowl to inspect and clean the filter. When reassembling the O-ring should be greased.

Alternative filter meshes are available. See section on Technical specifications - Filters and nozzles.

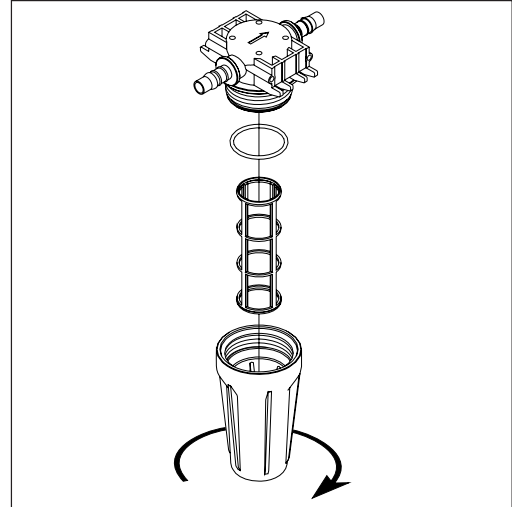

10 hours service - Nozzle filters

Check and clean.

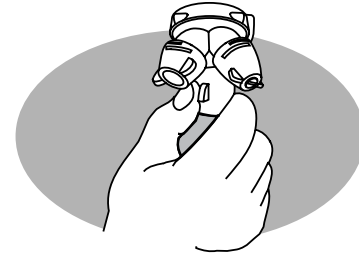

10 hours service - Spraying circuit

Fill with clean water, operate all functions and check for leaks using higher spray pressure than normal. Check nozzle spray patterns visually using clean water.

50 hours service - Transmission shaft

Check function and condition of the transmission shaft protection guard. Replace possible damaged parts.

50 hours service - Wheel bolts and nuts

Tighten wheel bolts and nuts as follows with following torque wrench settings:

Wheel hub to rim plate: 160 Ft/lb (215 Nm)

Tightening sequence: See illustration and tighten in order of numbering.

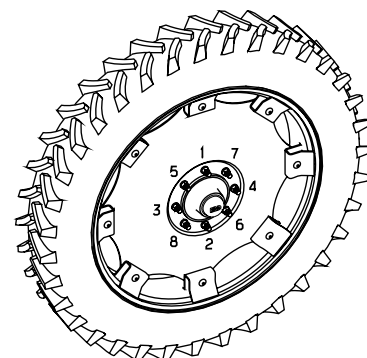

50 hours service - Tire pressure

Check the tire pressure according to the table in "Technical specifications".



DANGER! Never inflate tires more than to the pressure specified in the table. Over-inflated tires can explode and cause severe personal injuries! See the part "Occasional maintenance - Change of tire".



WARNING! If replacing tires, always use tires with min. load index as specified.

250 hours service - Readjustment of the boom

See section "Occasional maintenance".

250 hours service - Hydraulic circuit

Check the hydraulic circuit for leaks and repair if any.



WARNING! Hoses for boom lifting device must be changed after every 5 years of use.

250 hours service - Hoses and tubes

Check all hoses and tubes for possible damages and proper attachment. Replace damaged hoses or tubes.

250 hours service - Wheel bearings

Check for play in the wheel bearings:

1. Place stop wedges in front of and behind LH wheel and jack up RH wheel.
2. Rock the RH wheel to discover possible play in the bearings.
3. If any play, support the wheel axle to prevent the trailer from falling down from the jack.
4. Remove hub cap (A) and cotter pin (B). Turn the wheel and tighten the castle nut (C) until a slight resistance in the wheel rotation is felt.
5. Loosen the castle nut until the first notch - horizontal or vertical - is aligned with the cotter pin hole in the shaft.
6. Fit a new cotter pin and bend it.
7. Fill the hub cap with fresh grease and screw it on to the hub again.
8. Repeat the procedure on LH wheel.

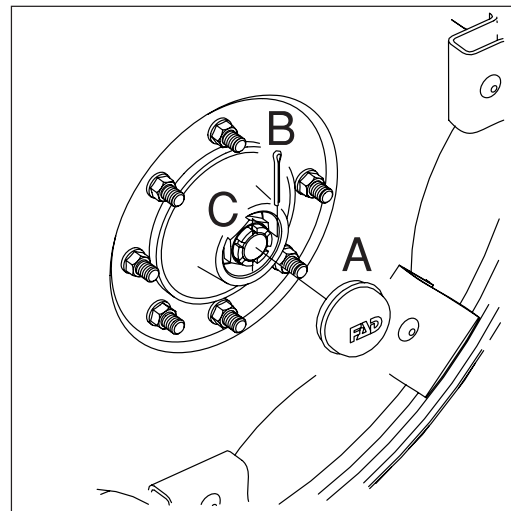

1000 hours service - Transmission shaft

Change the protection tube nylon bearings as described under "Shield replacement on transmission shaft".

6 - Maintenance

1000 hours service - Wheel bearings

Check the condition of the bearings in the following way:

1. Place stop wedges in front of and behind LH wheel and jack up RH wheel.
2. Support the trailer with axle stands.
3. Remove the wheel.
4. Remove the hub cap (A), cotter pin (B) and castle nut (C).
5. Pull off the wheel hub assembly. Use a wheel puller if necessary.
6. Remove roller bearings (D), clean all parts in degreasing detergent and dry them. Replace if worn or damaged.
7. Fill the hub and bearings with fresh grease.
8. Assemble the hub and bearings using a new sealing ring (E).
9. Fit castle nut. Rotate hub and tighten castle nut until a slight rotation resistance is felt.
10. Loosen castle nut again until the first notch is aligned with the cotter pin hole in the shaft.
11. Fit a new cotter pin and bend it.
12. Fill the hub cap with fresh grease and carefully press it onto the hub.
13. Replace the wheel and tighten the wheel nuts (See "50 hours service - Wheel bolts and nuts" for torque settings).
14. Tighten again after 10 hours of work. Check the torque every day until it is stabilized.

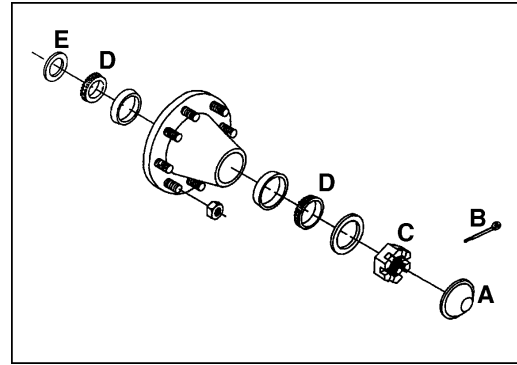

ATTENTION! The shaft has a vertical and a horizontal cotter pin hole. Use the one first aligned with the notch when loosening the castle nut.



WARNING! If you do not feel totally confident changing wheel bearings, contact your HARDI® dealer's workshop.

Occasional maintenance

General info

The maintenance and replacement intervals for the following will depend very much on the conditions under which the sprayer will be operated and are therefore impossible to specify.

Pump valves and diaphragms replacement

Model 363 and 463 pumps:

Diaphragm pump overhaul kit (valves, seals, diaphragms etc.) can be ordered. Detect whether the pump is a 363 or a 463 model - kit can be ordered at following HARDI® part No.:

Model 363: part No. 750342

Model 463: part No. 750343

Valves

Remove valve cover (1). Before changing the valves (2) - note their orientation so they are replaced correctly!



ATTENTION! A special valve with white flap (2A) is used at the two upperside inlets. It has to be placed in the valve openings as shown. All others are the type with black flap. It is recommended to use new gaskets (3) when changing or checking the valves.

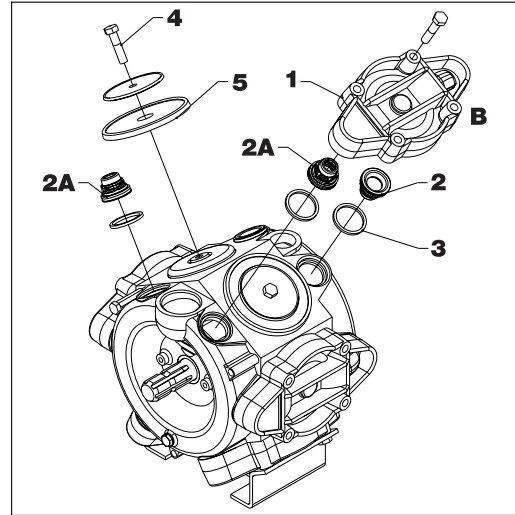

Diaphragms

Remove the diaphragm bolt (4). The diaphragm (5) may then be changed. If fluids have reached the crankcase, re-grease the pump thoroughly. Also check that the drain hole at the bottom of the pump is not blocked.

Reassemble pump model 363/463 with the following torque setting.

463 Diaphragm cover: 65 Ft/lb (90 Nm)

463 Diaphragm bolt: 60 Ft/lb (80 Nm)

363 Diaphragm cover: 50 Ft/lb (70 Nm)

363 Diaphragm bolt: 45 Ft/lb (60 Nm)

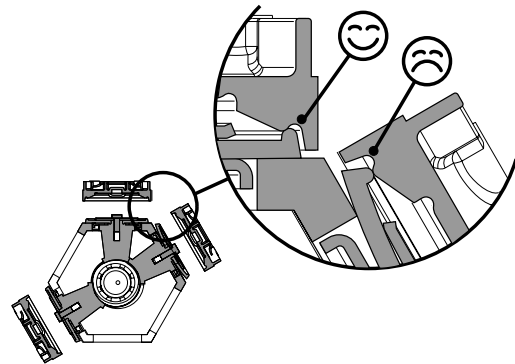

ATTENTION! Before tightening the 4 bolts for the diaphragm cover (B) the diaphragm must be positioned between center and top to ensure correct sealing between diaphragm pump housing and diaphragm cover. Turn crank shaft if necessary.

6 - Maintenance

Pump valves and diaphragms replacement

Model 1303 pumps:

Diaphragm pump overhaul kit (valves, seals, diaphragms etc.) can be ordered.

Model 1303: part No. 750658

Valves

Remove valve cover (1). Before changing the valves (2) - note their orientation so they are replaced correctly! It is recommended to use new O-rings (3) when changing or checking valves.

Diaphragms

Remove the diaphragm cover (4). Remove the diaphragm bolt. The diaphragm (5) may then be changed. If fluids have reached the crankcase, re-grease the pump thoroughly. Also check that the drain hole at the bottom of the pump is not blocked.

Reassemble with the following torque setting.

Valve cover: 45 Ft/lb (60 Nm)

Diaphragm cover: 50 Ft/lb (70 Nm)

Diaphragm bolt: 45 Ft/lb (60 Nm)

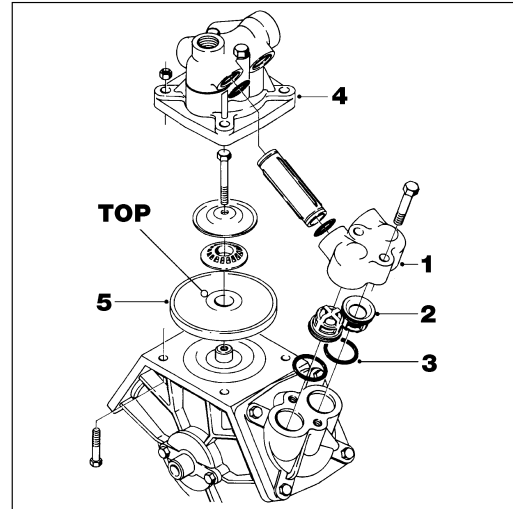

Cone check/replacement for EVC operating unit

If it becomes difficult to build up sufficient pressure or if pressure fluctuations occur, it may be necessary to replace cone and cylinder.

1. Remove 4 x screws (A) and remove the housing.
2. Remove 4 x screws (B).
3. Replace cylinder (C) and O-ring (D).
4. Loosen the nut (E), remove and replace the cone (F).
5. Reassemble in reverse order.

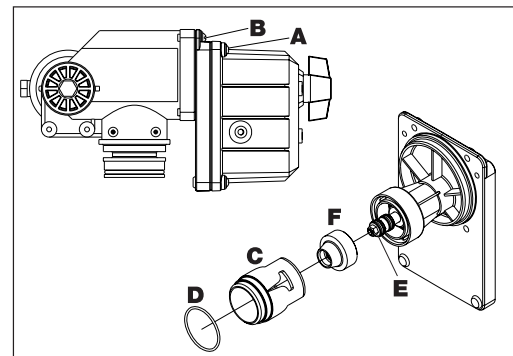

6 - Maintenance

Cone check/replacement for EVC distribution valve

Periodically check the distribution valves for proper sealing. Do this by running the sprayer with clean water and open all distribution valves. Cautiously remove the clip (A) and pull out the hose (B) for the return line. When the housing is drained, there should be no liquid flow through the return line. If there is any leakage, the valve cone (E) must be changed. Remove the clip (C) and lift the motor housing off the valve housing. Then unscrew the screw (D) and replace the valve cone (E). Reassemble in reverse order.

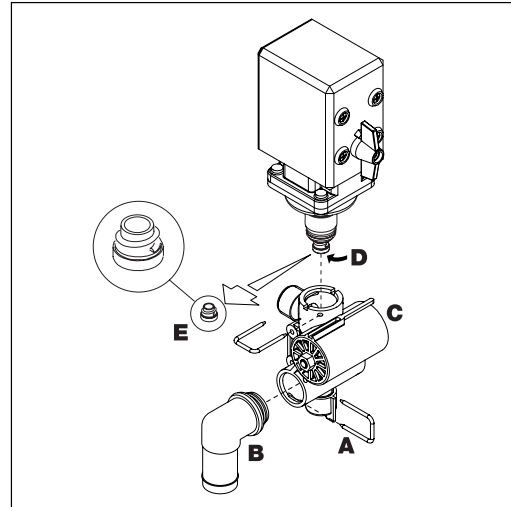

Level indicator adjustment

The level indicator reading should be checked regularly. When the tank is empty, the float should lie on the stop pin, of the rod, and the O-ring on the indicator should be positioned at the top position line (A).

If any deviation is found, pull out the plug (B), loosen screws (C), and adjust the length of the cord.

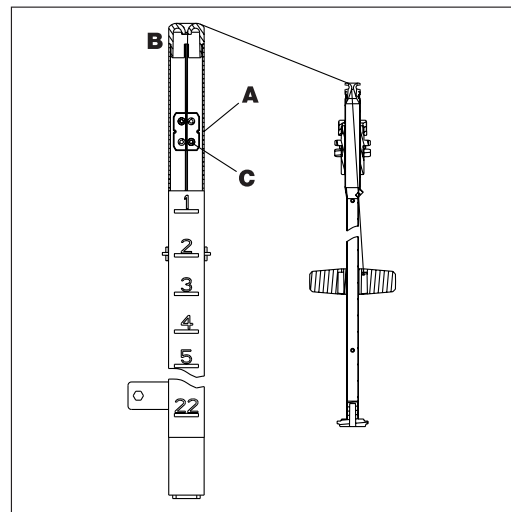

Level indicator cord replacement

If the cord on the level indicator has to be changed, the float guide pole is removed:

1. Remove the tank drain valve (see paragraph "Drain valve seal replacement") and loosen the fitting holding the pole in position.
2. Pull the pole down through the drain valve hole till it is free in the top of the tank.
3. The pole can now be taken out of the tank through the filling hole.



DANGER! Do not enter the inside of the tank - the parts can be changed from the outside of the tank!

6 - Maintenance

Drain valve seal replacement

If the main tank drain valve leaks, the seal and seat can be changed the following way.



DANGER! Do not enter the inside of the tank - the parts can be changed from the outside of the tank!



WARNING! Use eye / face protection mask when dismantling the tank drain valve!

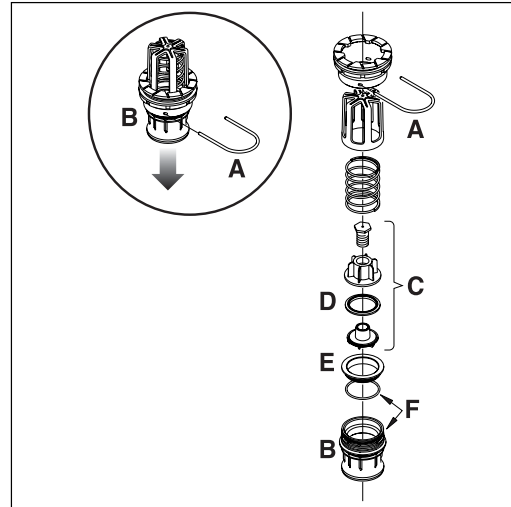

ATTENTION! Check function of valve with clean water before filling chemicals into the tank.

Nozzle tubes and fittings

Poor seals are usually caused by:

- Missing O-rings or gaskets
- Damaged or incorrectly seated O-rings
- Dry or deformed O-rings or gaskets
- Foreign bodies

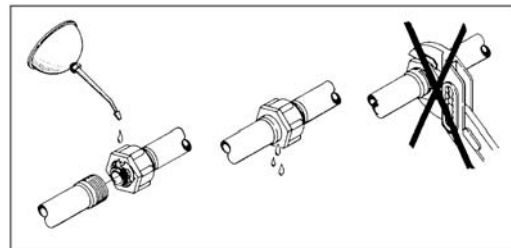

In case of leaks:

DO NOT overtighten. Disassemble, check condition and position of O-ring or gasket. Clean, lubricate and reassemble.

The O-ring must be lubricated ALL THE WAY ROUND before fitting on to the nozzle tube. Use non-mineral lubricant.

For AXIAL connections, a little mechanical leverage may be used.

For RADIAL connections only hand-tighten them.

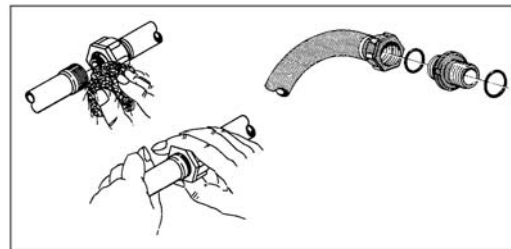

Adjustment of 3-way-valve

The MANIFOLD valve can be adjusted if it is too tight to operate - or if it is too loose (=liquid leakage). Correct setting is when the valve can be operated smoothly by one hand. Use a suitable tool and adjust the toothed ring inside the valve as shown on the drawing.

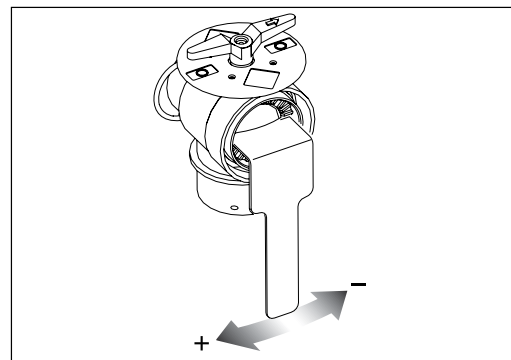

Readjustment boom - general info

Before commencing adjustment jobs please go through this check list.

1. The sprayer must be well lubricated (see part about lubrication).
2. Connect the sprayer to the tractor.
3. Place tractor and sprayer on level ground (horizontal).
4. Unfold boom.
5. Set slanting angle to neutral position (horizontal).

Adjustment of hydraulic cylinders are done without pressure in the system.



WARNING! Nobody is allowed to be under the boom while adjustment is carried out.

Alignment of center and inner wing sections

1. Unfold the boom and check alignment of the inner section with the center section.
2. If adjustment is necessary, relieve pressure from the cylinder by folding the boom a few inches.
3. Disconnect cylinder rod eye (A) from the inner section. Note that some cylinder rods have a machined flat which can be used for adjustments. If using this one for adjustment, leave the rod eye pinned to the boom.
4. Loosen jam nut (B) and adjust the length of the rod eye (A).
IN = to move the boom forward
OUT = to move the boom rearward
5. Tighten the jam nut (B) again. (Reattach the cylinder rod to the boom again, if it has been loosened).
6. Pressurize the cylinder to check boom alignment.

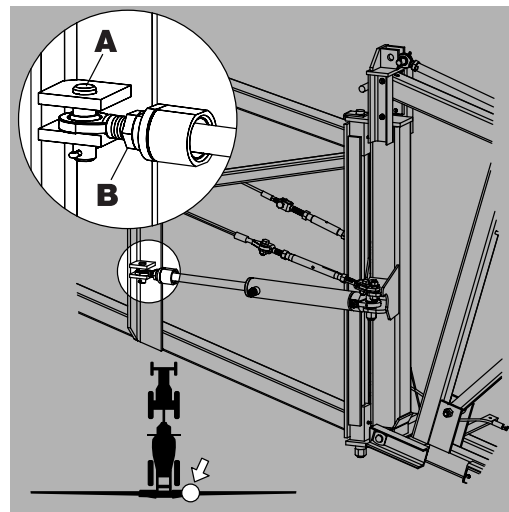

Alignment of inner and outer wing sections

1. Unfold the boom and check that the boom wing is aligned. If adjustment is needed:
2. Remove rubber stop (A) from the inner section.
3. Adjust the position of the adjusting bolt (B) on the inner section so that the cap of the bolt head (B) contacts top stop plate on outer section with inner and outer sections aligned. Tighten it in this position.
4. Replace stop device (A).

Please note that the rubber stop (A) should be compressed 1/8"-3/16" (3-5 mm). Therefore, check that the distance between the tabs (C) is a little less than the length of the rubber stop itself. The rubber stop may need to be spaced out with 1 or more flat washers in order to obtain correct compression. Tighten nut to hold it in place.

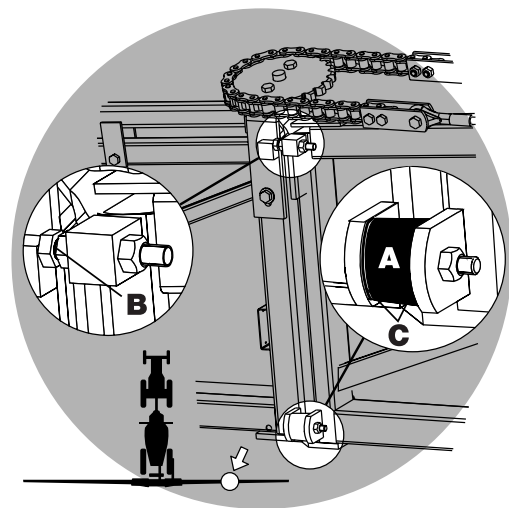

6 - Maintenance

Adjusting the front fold cable

The performance of the SPB boom while spraying depends very much on the front fold cable adjustment. A correctly adjusted cable will also control the movement of the outer section.



WARNING! The rear cable can snap and injure you or someone else if tensioned when the boom is unfolded. Always adjust the front cable first - with the boom unfolded and the rear cable last - with the boom folded in transport position.

1. Unfold the boom.
2. Check security of turnbuckle anchors to its hinges.
3. Slide a straight edge (A) down the underside of the inner section until it contacts the front cable = contact point (B).
4. Suspend a 10 lb (4.5 kg) weight (C) from the straight edge-to-cable contact point (B) and check deflection by measuring the distance from the straightedge to the cable (D). Cable should deflect .25 - .50 in. (13-22 mm).

If adjustment is needed:

5. Loosen jam nuts (E) on the turnbuckle assembly and adjust turnbuckle (F) for proper cable deflection.
6. Tighten jam nuts (E) again and remove weight.



WARNING! Check boom alignment again. If front cable was tightened, the wing assembly will move a bit forward. If front cable was loosened, the wing assembly will move a bit rearward. Therefore, adjust fold cylinder, if necessary, as described in the section 'Alignment of center section and inner wing sections'.

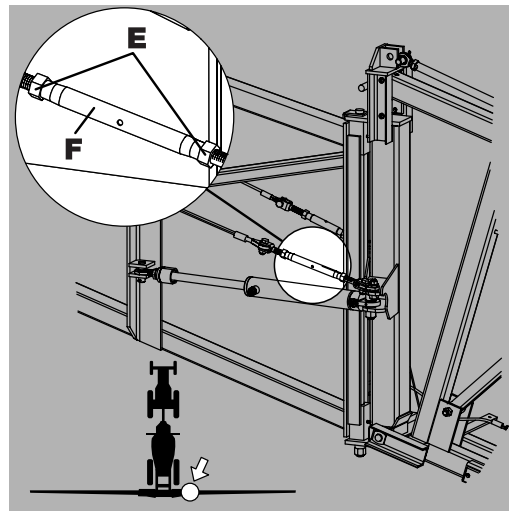
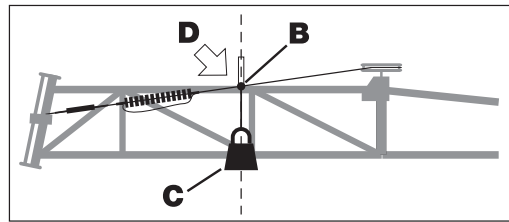
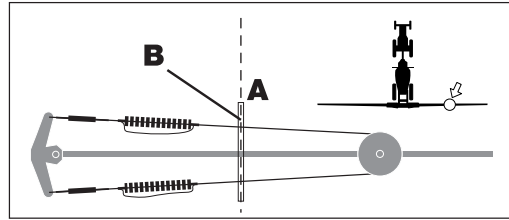

Breakaway section adjustment

The function of the breakaway section is to prevent or reduce boom damage, should it strike an object or the ground.

Check that the lower nut (A) is fully tightened. The breakaway should release with a force of 18 lbs (80 N) at the extremity. Please note that the clutch must be well greased before adjustment is commenced.

To adjust, loosen jam nut (B). Tighten nut (C) to stiffen clutch action. Tighten jam nut (B) after adjustment.



ATTENTION! Properly lubricate clutch assembly before adjusting the tension. Bolts (D) must be torqued to 40 Ft/lb (55 Nm) every 40 hours to prevent boom damage. Lubricate every 8 hours to ensure maximum performance and life.

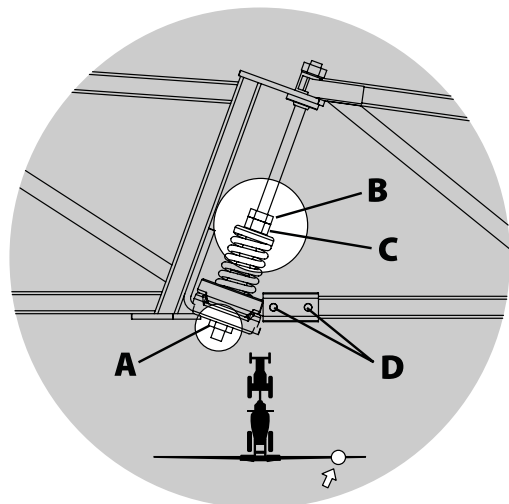

Check/adjust sprocket timing

1. Unfold the boom and stand on its rear side.
2. Check that the pin connection (A) in the timing chain is aligned with the center line (B) between the sprocket. Note forward driving direction (C) - adjustment is done at rearside of the boom. (A) is the 7th pin connection on the chain.
3. To adjust timing, loosen turnbuckles on the front and rear cables until slack.
4. Line up the chain and sprocket as indicated in step 2 above.

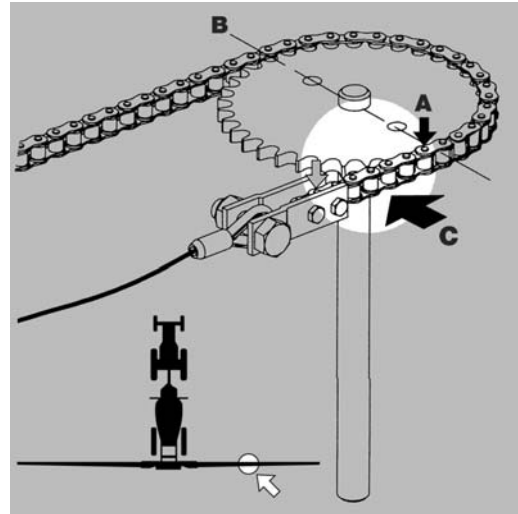

Adjusting boom level to ground

Unfold the boom and check that the boom sections are parallel to the center frame and level to the ground. Adjust if necessary, as described below. Adjustment is carried out with the boom unfolded.

For SPB-HY models the following procedure is used:

1. Loosen jam nut (A).
2. Adjust nut (B) - in or out - until boom wing is level to the ground.
3. Secure jam nut (A) again.

Same procedure applies to both sides.

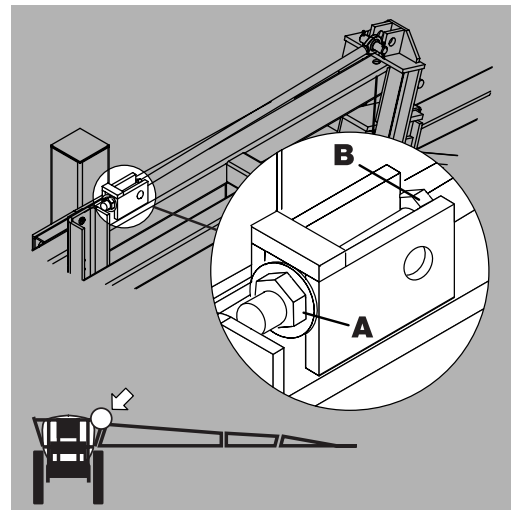

For SPB-HZ models the following procedure is used:

1. Ensure that cylinder is fully extended.
2. Loosen jam nut (A).
3. Apply an adjustable wrench to the machined surface at (B).
4. Turn the cylinder rod until boom is level to the ground.
5. Secure jam nut (A) again.

Same procedure applies to both sides.

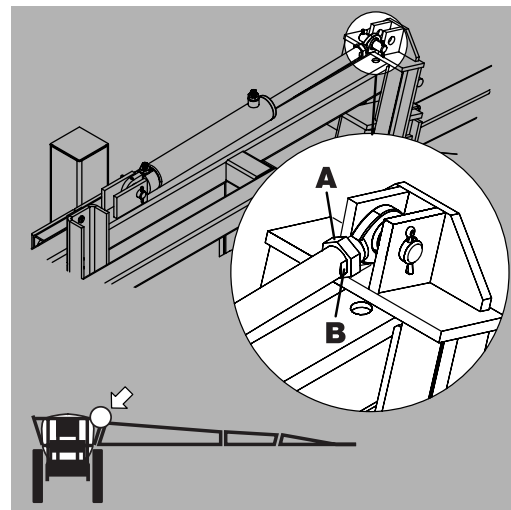

6 - Maintenance

Adjusting rear cable

1. Raise boom to its highest position. Fold it to transport position with tilt cylinders fully extended. Make sure that fold cylinders are pressurized and that the boom is folded all the way in.
2. Ensure the boom transport brackets are in contact with the outer wing. Adjust if necessary.
3. Loosen the jam nuts (E) on the ends of turnbuckle (F). Adjust the turnbuckle (F) so that the outer section contacts the boom transport bracket.

Turn the turnbuckle another 4 complete turns.

4. Secure jam nuts (E) again.



WARNING! The rear cable can snap and injure you or someone else if tensioned when the boom is unfolded. Always adjust the front cable first - with the boom unfolded and the rear cable last - with the boom folded in transport position.

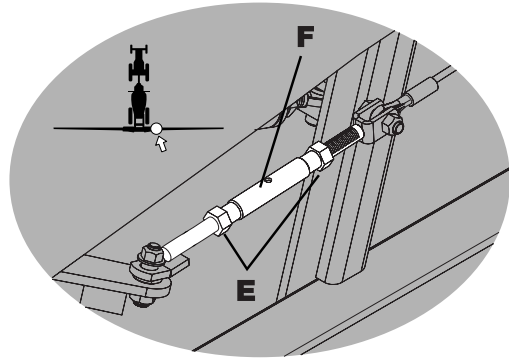

Adjusting center section cables

The center section cables keep the center frame in correct position during folding procedure or when spraying with one side raised and folded (SPB-HZ only).

1. Fold the boom into transport position.
2. Check that the tilt cylinders are completely extended. Adjust if necessary (SPB-HZ only).
3. Check that center section cable (A) is routed over center section nozzle bracket (B).
4. Loosen jam nuts on the bolt assembly (C). This applies both boom wings.
5. Adjust the threaded bolt(s) (C). Alternate from side-to-side while making adjustments. As a guideline for adjustment, the distance (D) shown at the bolt assembly should be 4-5/16" (110 mm). Properly adjusted cables will be very tight and only deflect a small amount (fractions of an inch) when pulled by hand. Note that cables will be loose when the boom is unfolded.
6. Tighten jam nuts on the bolt assembly (C) again.
7. Unfold the boom and inspect that the center frame is correctly centered.



ATTENTION! Adjust both boom wings in one sequence. Adjust one cable a small amount at the time, and then the other cable, to equalize cable tension and maintain a level center frame.



WARNING! Never adjust the center cables without having folded the boom all the way into the transport position.

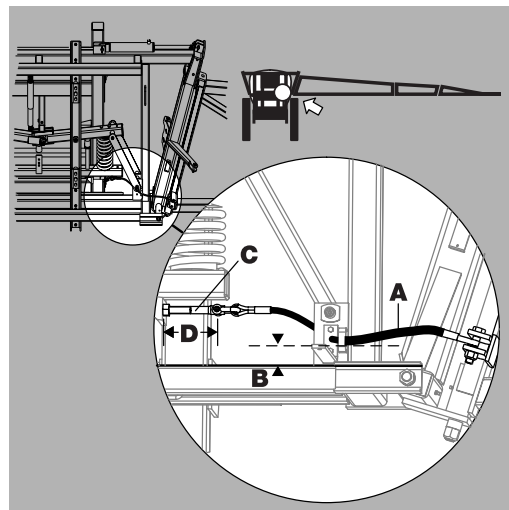

Shock absorbers

If the shock absorbers lose their efficiency or start leaking oil, they should be replaced.

Wear bushing replacement on boom lift

The wear bushings are inspected and replaced before they are worn through.

1. Connect the trailer to a tractor and unfold the booms to working position.
2. Lift the boom center frame with a lifting device and support it until the load is taken off the parallelogram arms.
3. The upper arms must be disconnected simultaneously.
4. Remove the screws (A), and pull out the pins (B) for the upper parallelogram arms and replace the wear bushings (C).
5. Replace the arms.
6. Repeat this procedure with each of the lower arms.
7. Grease all grease nipples.
8. Remove the lifting gear again.

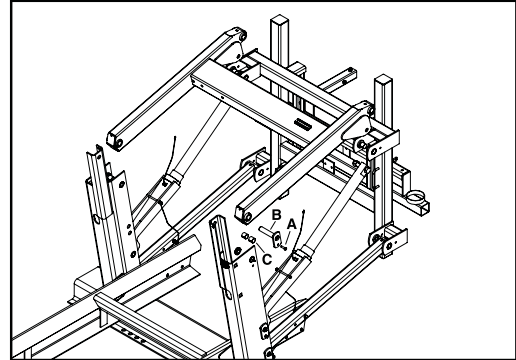

Change of tire

Should it be necessary to replace tires, it is recommended to leave this to a specialist and follow the mentioned rules.

1. Always clean and inspect the rim before mounting.
2. Always check that the rim diameter corresponds exactly to the rim diameter molded on the tire.
3. Always inspect inside of the tire for cuts, penetrating objects or other damages. Repairable damages should be repaired before installing the tube. Tires with unreparable damages must never be used.
4. Also inspect inside of the tire for dirt or foreign bodies and remove it before installing the tube.
5. Always use tubes of recommended size and in good condition. When fitting new tires always fit new tubes.
6. Before mounting, always lubricate both tire beads and rim flange with approved lubricating agent or equivalent anti-corrosion lubricant. Never use petroleum based greases and oils because they may damage the tire. Using the appropriate lubricant the tire will never slip on the rim.
7. Always use specialized tools as recommended by the tire supplier for mounting the tires.
8. Make sure that the tire is centered and the beads are perfectly seated on the rim. Otherwise danger of bead wire tear can occur.
9. Inflate the tire to 15-19 p.s.i. (100-130 kPa) then check whether both beds are seated perfectly on the rim. If any of the beads do not seat correctly, deflate the assembly and re-center the beads before starting inflation of the tire. If the beads are seated correctly on the rim at 15-19 p.s.i., inflate the tire to a maximum of 36 p.s.i. (250 kPa) until they seat perfectly on the rim.
10. Never exceed the maximum mounting pressure molded on the tire!
11. After mounting tires adjust inflation pressure to operation pressure recommended by the tire manufacturer.
12. Do not use tubes in tubeless tires.



DANGER! Non observance of mounting instructions will result in the bad seating of the tire on the rim and could cause the tire to burst leading to serious injury or death!



DANGER! Never mount or use damaged tires or rims! Use of damaged, ruptured, distorted, welded or brazed rim is not allowed!

6 - Maintenance

Change of bulbs

1. Switch off the light.
2. Loosen the screws on the lamp and remove the cover or lens.
3. Remove the bulb.
4. Fit a new bulb, refit the cover and tighten the screws.



ATTENTION! If halogen bulbs are used, never touch the bulb with the fingers. Natural moisture in the skin will cause the bulb to burn out when the light is switched on. Always use a clean cloth or tissue when handling halogen bulbs.

Shield replacement on transmission shaft

1. Remove bolt (A), lock (B) and grease nipple (C). Twist uni CV-joint cover 1/4 turn and pull it backwards.
2. Remove the synthetic bearings and protection tube.
 - 2a. Remove inner bush from protection tube.
3. Assemble again in reverse order, using new parts where necessary. Remember to fit chains again.
4. Grease bearings.
5. Repeat procedure to the opposite part of the transmission shaft.



ATTENTION! Only use genuine HARDI® spare parts to service the transmission shaft.

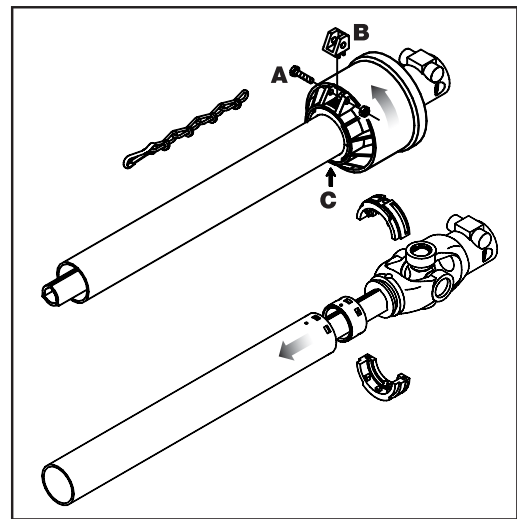

Replacement of transmission shaft cross journals.

1. Remove protection guard as described previously.
2. Remove Seeger circlip rings.
3. Press the cross journal sideways - use hammer and mandrel if necessary.
4. Remove needle bearing cups and cross journal can now be removed.
5. Carefully remove needle bearing cups from new cross journal and install it in reverse order. Before fitting the needle bearing cups again, check that needles is placed correctly. Avoid dust and dirt in the new bearings.
6. Repeat procedure to the opposite part of the transmission shaft.

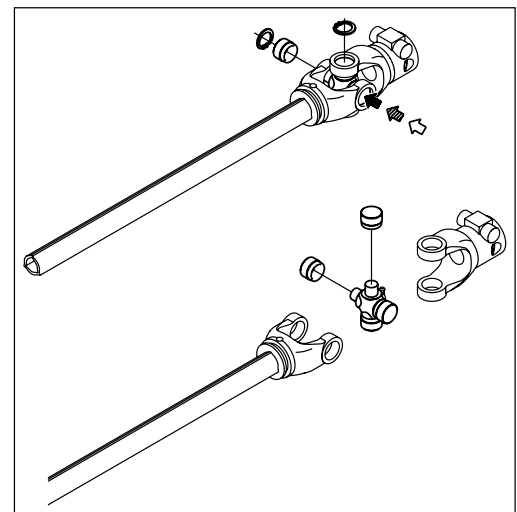

Off-season storage

Off-season storage program

When the spraying season is over, you should devote some extra time to the sprayer. If chemical residue is left over in the sprayer for longer periods, it can reduce the life of the individual components. To preserve the sprayer intact and to protect the components, carry out following off-season storage program.

1. Clean the sprayer completely - inside and outside - as described under "Cleaning of the sprayer". Make sure that all valves, hoses and auxiliary equipment have been cleaned with detergent and flushed with clean water afterwards, so no chemical residue is left in the sprayer.
2. Replace possible damaged seals and repair possible leaks.
3. Empty the sprayer completely and let the pump work for a few minutes. Operate all valves and handles to drain as much water off the spraying circuit as possible. Let the pump run until air is coming out of all nozzles. Remember to drain the flush tank also.



ATTENTION! If the sprayer is equipped with a centrifugal pump, do not run pump dry for longer than 3 seconds. Otherwise severe damage to the pump will occur.

4. Pour appr. 13 gal. (50 liters) anti-freeze mixture consisting of 1/3 automotive anti-freeze and 2/3 water into the tank.
5. Engage the pump and operate all valves and functions on the MANIFOLD, operating unit, chemical inductor etc. allowing the anti-freeze mixture to be distributed around the entire circuit. Open the operating unit main on/off valve and distribution valves so the anti-freeze is sprayed through the nozzles as well. The anti-freeze will also prevent O-rings, seals, diaphragms etc. from drying out.
6. Lubricate all lubricating points according to the lubricating scheme - regardless of intervals stated.
7. When the sprayer is dry, remove rust from possible scratches or damages in the paint and touch up the paint.
8. Remove the glycerine-filled pressure gauges and store them frost free in vertical position.
9. Apply a thin layer of anti-corrosion oil (e.g. SHELL ENSIS FLUID, CASTROL RUSTILLO or similar) on all metal parts. Avoid oil on rubber parts, hoses and tires.
10. Fold the boom in transport position and relieve pressure from all hydraulic functions.
11. All electric plugs and sockets are to be stored in a dry plastic bag to protect them against damp, dirt and corrosion.
12. Remove the control boxes and computer display from the tractor, and store them dry and clean (in-house).
13. Wipe hydraulic snap-couplers clean and fit the dust caps.
14. Apply grease on all hydraulic ram piston rods which are not fully retracted in the barrel to protect against corrosion.
15. Chock up the wheels, to prevent moisture damage and deformation of the tires. Tire blacking can be applied to the tire walls to preserve the rubber.
16. To protect against dust the sprayer can be covered by a tarpaulin. Ensure ventilation to prevent condensation.

Preparing the sprayer for use after storage

After a storage period the sprayer should be prepared for the next season the following way:

1. Remove the cover.
2. Remove the support from the wheel axle and adjust the tire pressure.
3. Wipe off the grease from hydraulic ram piston rods.
4. Fit the pressure gauges again. Seal with Teflon tape.
5. Connect the sprayer to the tractor including hydraulics and electric's.
6. Check all hydraulic and electric functions.
7. Empty the tank for remaining anti-freeze.
8. Rinse the entire liquid circuit on the sprayer with clean water.
9. Fill with clean water and check all functions.

6 - Maintenance

Operational problems

General info

In cases where breakdowns have occurred, the same factors always seem to come into play:

1. Minor leaks on the suction side of the pump will reduce the pump capacity or stop the suction completely.
2. A clogged suction filter will hinder or prevent suction so that the pump does not operate satisfactorily.
3. Clogged up pressure filters will result in increasing pressure at the pressure gauge but lower pressure at the nozzles.
4. Foreign bodies stuck in the pump valves with the result that these cannot close tightly against the valve seat. This reduces pump efficiency.
5. Poorly reassembled pumps, especially diaphragm covers, will allow the pump to suck air resulting in reduced or no capacity.
6. Hydraulic components that are contaminated with dirt result in rapid wear to the hydraulic system.

Therefore ALWAYS check:

1. Suction, pressure and nozzle filters are clean.
2. Hoses for leaks and cracks, paying particular attention to suction hoses.
3. Gaskets and O-rings are present and in good condition.
4. Pressure gauge is in good working order. Correct dosage depends on it.
5. Operating unit functions properly. Use clean water to check.
6. Hydraulic components are maintained clean.

7 - Fault finding

Liquid system

FAULT	PROBABLE CAUSE	CONTROL/REMEDY
No spray from boom when turned on.	Air leak on suction line.	Check if suction filter O-ring is sealing. Check suction tube and fittings. Check tightness of pump diaphragm and valve covers.
	Air in system (Centrifugal pump).	Bleed air from centrifugal pump.
	Suction/pressure filters clogged.	Clean filters. Check for obstruction near tank sump elbow fitting.
Lack of pressure.	Incorrect assembly.	Check for obstruction near tank sump elbow fitting.
	Pump valves blocked or worn.	Check for obstructions and wear.
	Defective pressure gauge.	Check for dirt at inlet of gauge.
Pressure dropping.	Filters clogging.	Clean all filters. Fill with cleaner water. If using powders, make sure agitation is on.
	Nozzles worn.	Check flow rate and replace nozzles if it exceeds 10%.
	Tank is air tight.	Check vent in tank lid is clear.
	Sucking air towards end of tank load.	Lower pump r.p.m.
Pressure increasing.	Pressure filters beginning to clog.	Clean all filters. Make sure bottom valve on CycloneFilter is not left in closed position (marked with 1 dot) after flushing boom. Operating position (marked with 2 dots) keeps CycloneFilter clean.
Formation of foam.	Air is being sucked into system.	Check tightness/gaskets/O-rings of all fittings on suction side.
	Excessive liquid agitation.	Reduce pump r.p.m. Check safety valve is tight (diaphragm systems only). Ensure returns inside tank are present.
		Use foam damping additive.
Liquid leaks from bottom of pump.	Damaged diaphragm.	Replace. See changing of valves and diaphragms.
Operating unit not functioning.	Blown fuse(s).	Check mechanical function of microswitches. Use cleaning/lubricating agent if the switch does not operate freely. Check motor. 450-500 milli-Amperes max. Change motor, if over.
	Wrong polarity.	Brown - pos. (+). Blue - neg. (-).
	Valves not closing properly.	Check valve seals for obstructions. Check microswitch plate position. Loosen screws holding plate 1/2 turn.
No power.		Wrong polarity. Check that brown is pos. (+), Blue is neg. (-). Check print plate for dry solders or loose connections. Check fuse holder are tight around fuse.

7 - Fault finding

Hydraulic system - HY model.

FAULT	PROBABLE CAUSE	CONTROL/REMEDY
Boom slow/erratic.	Air in system.	Loosen ram connection and activate hydraulics until oil flow has no air in it (not whitish).
	Insufficient hydraulic pressure.	Check output pressure of tractor hydraulics. Minimum for sprayer is 2000 psi (130 bar).
	Insufficient amount of oil in tractor reservoir.	Check and top if needed.
Ram not functioning.	Restrictor blocked.	Secure boom. Dismantle and clean. Change hydraulic oil & filter.

Hydraulic system - HZ model.

FAULT	PROBABLE CAUSE	CONTROL/REMEDY
No boom movements when activated.	Insufficient hydraulic pressure.	Check output pressure of tractor hydraulics. Minimum for sprayer is 2000 psi (130 bar).
	Insufficient amount of oil in tractor reservoir.	Check and top if needed.
	Blown fuse(s).	Check / replace fuse in junction box.
	Bad / corroded electrical connections.	Check / clean connections, multi plugs, etc.
	Insufficient power supply.	Voltage on activated solenoid valve must be more than 8 Volts. Use wires of at least 10 awg. (4mm ²) for power supply.
	Defective relay / diodes in junction box.	Check relays, diodes and soldering at PCB in junction box.
Ram not functioning.	Restrictor blocked.	Secure boom. Dismantle and clean. Change hydraulic oil & filter.
Hydraulic system fold/tilt functions will not operate.	Power supply.	Check for proper 12V power supply.
One function (fold or tilt) will not operate.	Various.	Check for defective switch(es).
		Check continuity of cables.
		Check for operation of applicable solenoid (coil not activating or plunger stuck).
		Check for short circuit in wiring junction box at rear of sprayer.
Multiple hydraulic functions with one switch activated.	Various.	Dirt in the restrictor port of the cylinder.
		Check for correct solenoid electric/hydraulic hook-up.
		Check for short circuit in wiring in the junction box at rear of sprayer.

7 - Fault finding

Mechanical problems

Mechanical problems

FAULT	PROBABLE CAUSE	CONTROL/REMEDY
Boom will not fold in or out.	Cylinder.	Adjust the fold cylinder.
Boom will not fold completely.	Cables.	Check adjustment of center cables.
Boom not aligned.	Cables.	Adjust and grease complete boom cables and stops.
Boom will not stay in spraying position.	Various.	Check for hydraulic leaks through solenoid block. Check for a solenoid that is stuck open.
Wing to be kept folded swings out when unfolding other side of the boom.	Various.	Boom must be completely unfolded - then fold out the desired boom wing. Check for hydraulic leaks through solenoid block. Check for a solenoid that is stuck open.

Emergency operation - Liquid system

In case of power failure it is possible to operate all functions of the operating unit manually. First disconnect the multi plug from the control box. Now manually turn the emergency control knobs.

The problem may be due to a blown fuse. A fuse is placed inside the box. Fuse type: Thermo

8 - Technical specifications

Dimensions

Overall dimensions

	A	B	C
2200 SPB	206	120	112

All measurements are in inches.

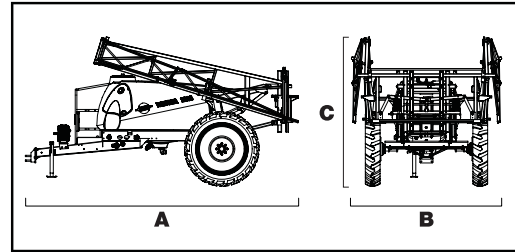

Specifications

Main tank capacity	1200 gallons (2200 Liters)
Clean water tank capacity	5 gallons (20 Liters)
Flush tank capacity	63 gallons (240 Liters)
Foam marker tank capacity	10, 15 or 20 gallons (38, 57 or 76 Liters)

Weight

	Total	Drawbar	Axle	Per tire
Unfolded empty	1574	39	1535	768
Folded empty	1574	163	1411	705
Unfolded full (water)	4449	831	3618	1809
Folded full (water)	4449	955	3494	1747

All measurements are in pounds.

Wheel and axle dimensions

Wheel	Min. track width	Max. track width	Clearance*
12.4x24"	60" (1520mm)	90" (2250 mm)	18" (460 mm)
13.6x38"	60" (1520mm)	90" (2250 mm)	24" (610 mm)

*under axle

8 - Technical specifications

Specifications

Diaphragm pumps

Pump model 1303/9.0	PSI	RPM	GPM	HP
	0	540	30.1	2.1
	29	540	28.2	2.3
	58	540	27.5	2.3
	88	540	26.9	2.4
	147	540	26.4	3.4
	220	540	25.9	4.4

Pump model 363/5.5	PSI	RPM	GPM	HP
	0	1000	53.1	4.2
	29	1000	50.4	4.3
	58	1000	49.6	4.8
	88	1000	49.1	5.8
	147	1000	47.5	7.5
	220	1000	45.9	9.5

Pump model 363/10.0	PSI	RPM	GPM	HP
	0	540	51.2	2.4
	29	540	49.9	3.1
	58	540	49.1	3.9
	88	540	48.6	4.6
	147	540	48.0	6.4
	220	540	47.0	8.4

Pump model 463/6.5	PSI	RPM	GPM	HP
	0	1000	91.9	4.3
	29	1000	84.8	5.4
	58	1000	82.7	6.8
	88	1000	81.4	8.3
	147	1000	78.2	11.0
	220	1000	75.5	13.8

Pump model 463/12.0	PSI	RPM	GPM	HP
	0	540	85.0	3.0
	29	540	83.7	4.2
	58	540	82.9	5.6
	88	540	81.3	6.9
	147	540	79.7	9.5
	220	540	77.9	9.9

Centrifugal pumps

Pump model ACE 206 hydraulic

Output will vary with PSI and usage.

Pump model ACE 150 PTO drive

Output will vary with PSI and usage.

8 - Technical specifications

Filters and nozzles

Filter gauze width
30 mesh: 0.58 mm
50 mesh: 0.30 mm
80 mesh: 0.18 mm
100 mesh: 0.15 mm

Temperature and pressure ranges

Operating temperature range: 36°F to 104°F (2° to 40° C)
Operating pressure for safety valve: 220 psi (15 bar)
Max. pressure on the pressure manifold: 290 psi (20 bar)
Max. pressure on the suction manifold: 100 psi (7 bar)

Tire pressure

Tire size	Rec. inflation pressure in p.s.i. (bar)
12.4 x 24	25 (1.7)
11.2 x 38	35 (2.4)



DANGER! Never inflate tires more than to the pressure specified in the table. Over-inflated tires can explode and cause severe personal injuries! See the part "Occasional maintenance - Change of tire".

Materials and Recycling

Disposal of the sprayer

When the equipment has completed its working life, it must be thoroughly cleaned. The tank, hose and synthetic fittings can be incinerated at an authorized disposal plant. The metallic parts can be scrapped. Always follow local legislation regarding disposal.

Materials used:

Tank: HDPE

Hoses: PVC

Valves: mainly glass-filled PA.

Fittings: PA

8 - Technical specifications

Electrical connections

Rear lights

The wiring is in accordance with ISO 1724.

Position	Wire color
1. LH direction indicator	Yellow
2. Free	Blue
3. Frame	White
4. RH direction indicator	Green
5. RH rear position lamp	Brown
6. Stop lamps	Red
7. LH rear position lamp	Black

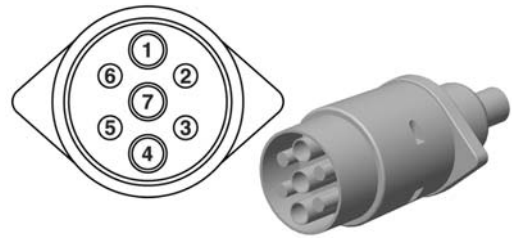

8 - Technical specifications

Electrical connections for SPRAY II

39 or 37 poled plug with cable.

39-pole	37-pole	SPRAY II
1a	5	S1+
1b	6	S1-
1c	26	End nozzle L
2a	7	S2+
2b	8	S2-
2c	25	End nozzle R
3a	9	S3+
3b	10	S3-
3c	29	+12V sensor
4a	11	S4+
4b	12	S4-
4c	4	PWM 1TX
5a	14	S5+
5b	15	S5-
5c	27	GND
6a	16	S6+
6b	17	S6-
6c	13	Optional 5 Reg. feedback
7a	18	S7+
7b	19	S7-
7c	33	Option 1 4-20mA
8a	37	S8+
8b	36	S8-
8c	32	Option 2 Frq
9a	35	S9+/Air angle 0-5V
9b	34	S9-/Fan speed 0-5V
9c	not connected	Option 3/Tank gauge
10a	21	On/off+
10b	22	On/off-
10c	not connected	PWM Output option
11a	23	Pressure+
11b	24	Pressure-
11c	28	Flow
12a	20	Foam blop 0-5V
12b	1	option 4 Rx
12c	31	Speed
13a	3	FM L
13b	2	FM R
13c	30	Gnd sensor

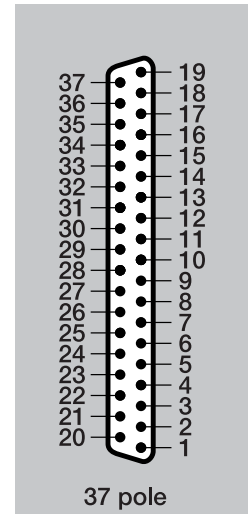
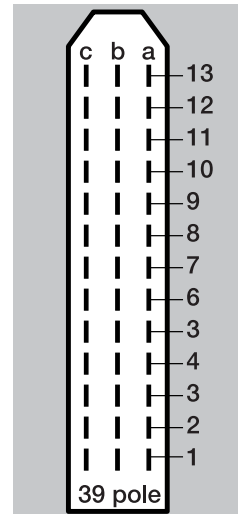

8 - Technical specifications

EVC

The EVC operating unit fulfills the EC noise reduction standards.

When connecting an optional function, be aware that maximum current for every connector is 2 Amp. Total current for the whole connector box may not exceed 10 Amp.

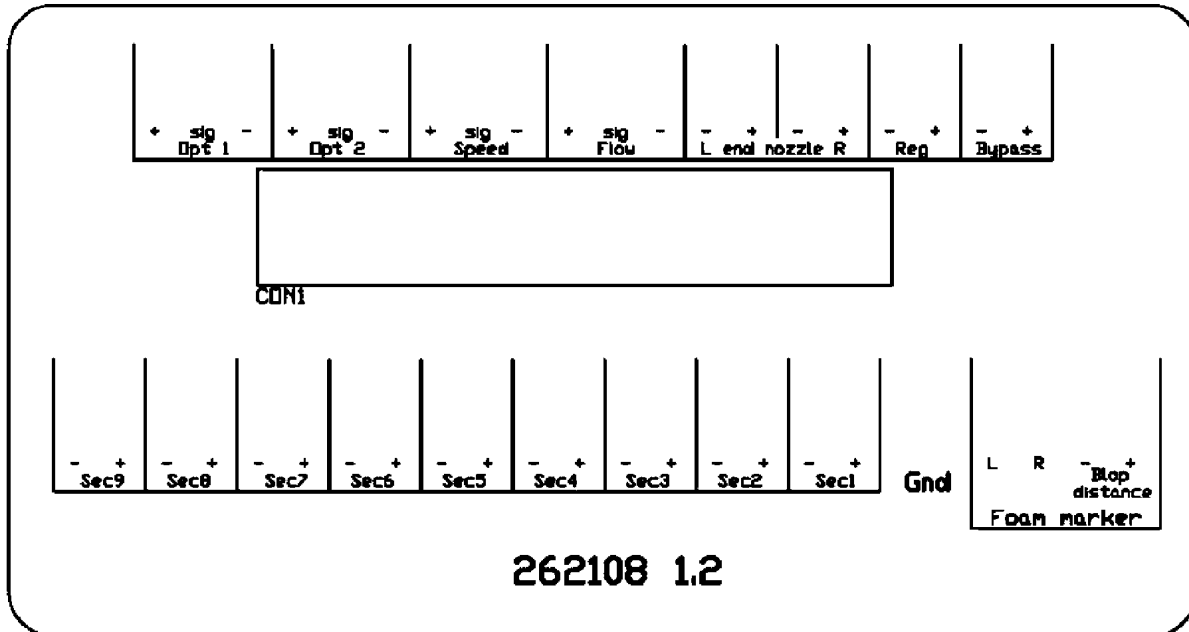

8 - Technical specifications

HC 2500	Function		+	Sig.	-
Opt 1	Pressure sensor		Brn	Blu	-
Opt 2	RPM sensor		Brn	Blu	Blk
Speed			Brn	Blu	Blk
Flow			Brn	Blu	Blk
L end nozzle	Pendulum lock at HAY/LPY		Brn		Blu
R end nozzle	Pendulum lock at HAY/LPY		Brn		Blu
Reg (Yellow)			Brn		Blu
Bypass	EC on/off		Brn		Blu
Sec 9	User defined A&B 2		x		x
Sec 8	User defined A&B 1		x		x
Sec 7	Twin speed		Brn		Whi
Sec 6	Twin angle		Yel		Gre
Sec 5			Brn		Blu
Sec 4			Brn		Blu
Sec 3			Brn		Blu
Sec 2			Brn		Blu
Sec 1			Brn		Blu

		Gnd	L	R	-	+
Foam marker	No. 4 Not used	2	6	5	1	3

HC 5500	Function		+	Sig.	-
Opt 1	Pressure sensor		Brn	Blu	-
Opt 2	RPM sensor or anemometer		Brn	Blu	Blk
Speed			Brn	Blu	Blk
Flow			Brn	Blu	Blk
L end nozzle	Pendulum lock at HAY/LPY		Brn		Blu
R end nozzle	Pendulum lock at HAY/LPY		Brn		Blu
Reg (Yellow)			Brn		Blu
Bypass	EC on/off		Brn		Blu
Sec 9	User defined A&B 2		x		x
Sec 8	User defined A&B 1		x		x
Sec 7	Twin speed		Brn		Whi
Sec 6	Twin angle		Yel.		Gre
Sec 5			Brn		Blu
Sec 4			Brn		Blu
Sec 3			Brn		Blu
Sec 2			Brn		Blu
Sec 1			Brn		Blu

		Gnd	L	R	-	+
Foam marker	No. 4 Not used	2	6	5	1	3

8 - Technical specifications

Charts

Boom hydraulics - HY

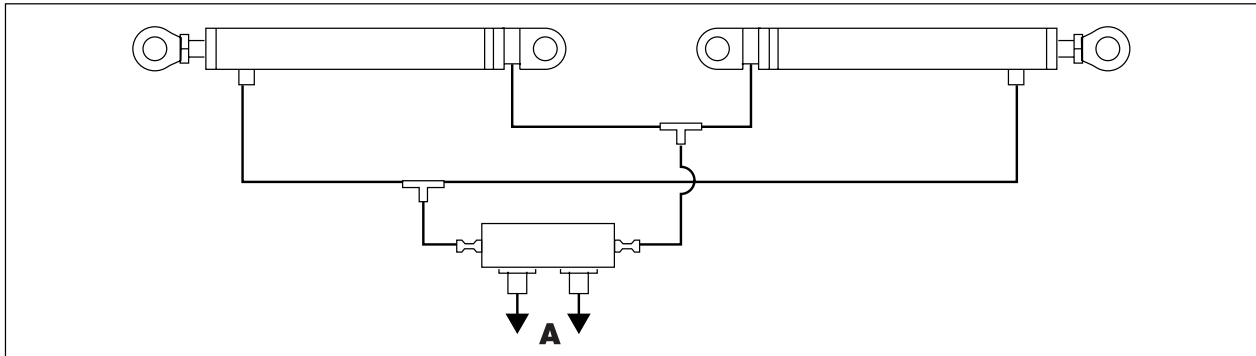

Boom hydraulics - HZ

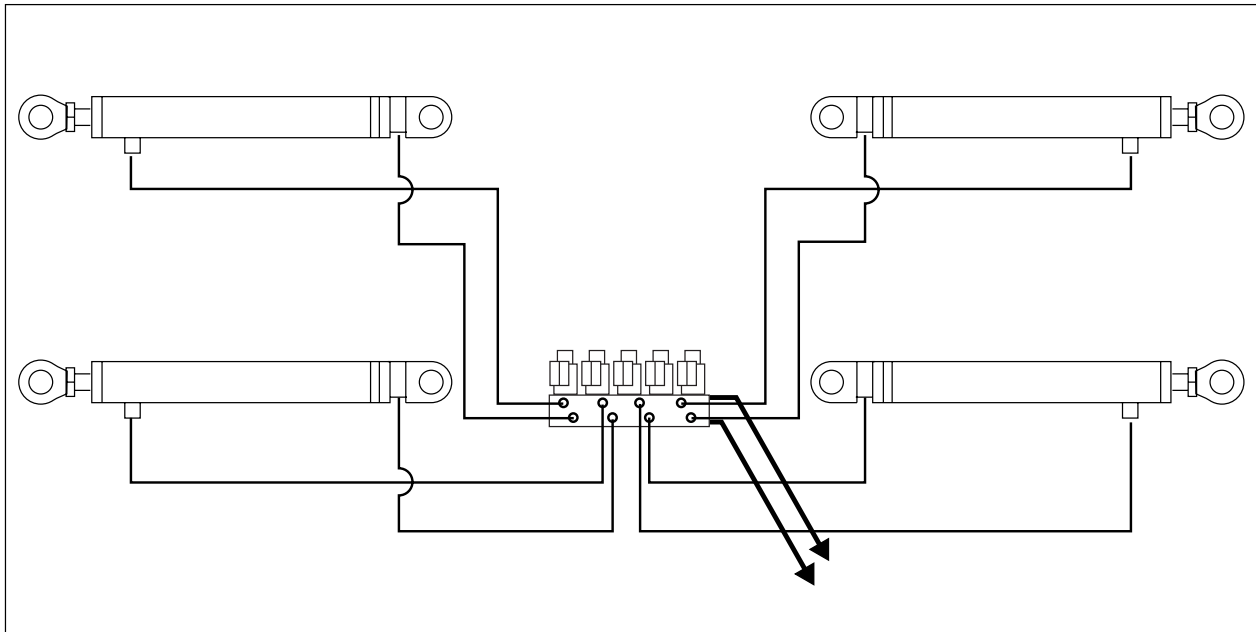

8 - Technical specifications

Boom hydraulics - DH

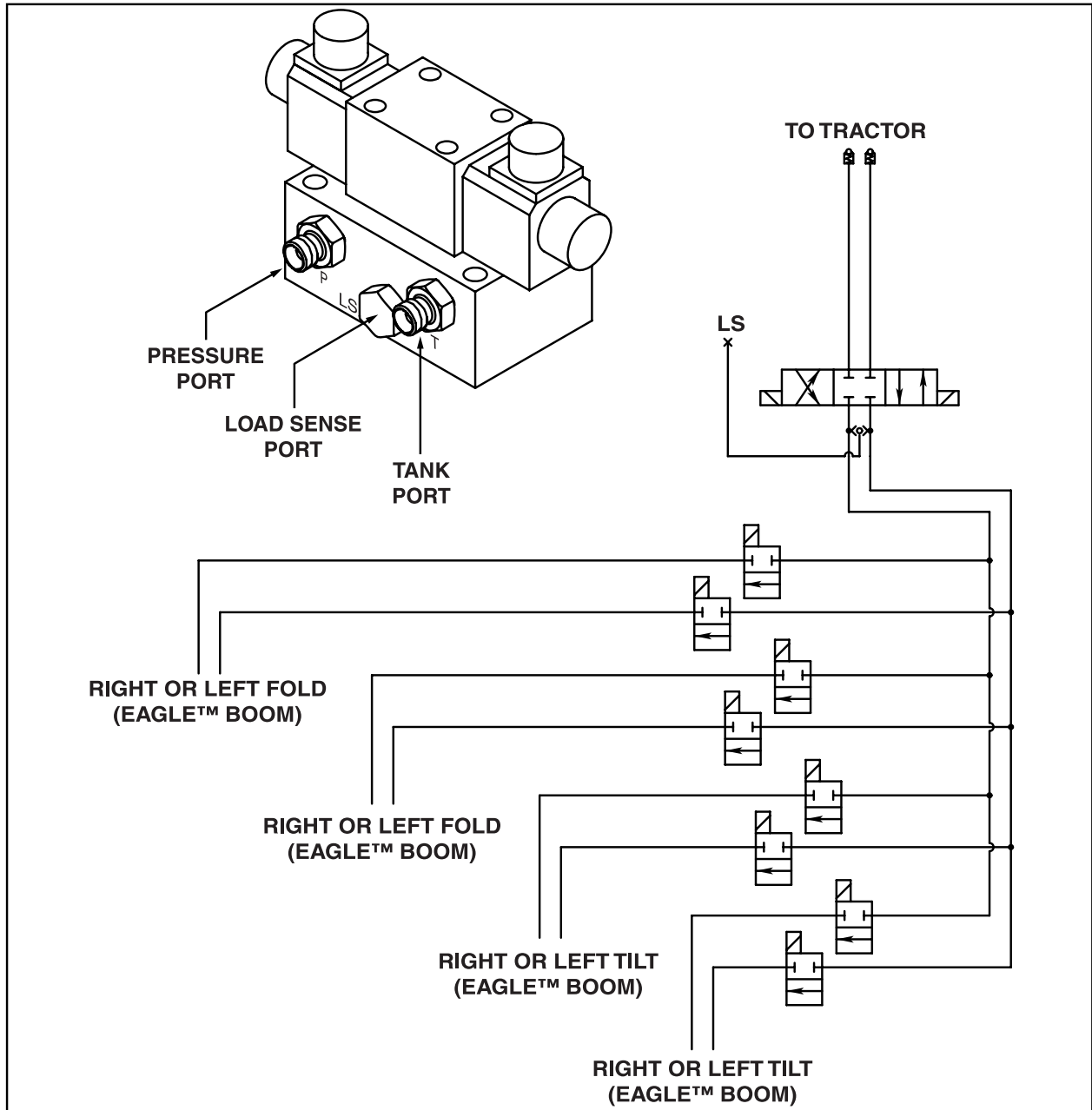

8 - Technical specifications

Warranty policy and conditions

HARDI® INC. , 1500 West 76th Street, Davenport, Iowa, USA; 8550 W. Roosevelt Avenue, Visalia, California, USA and 290 Sovereign Road, London, Ontario, Canada hereinafter called "HARDI®", offers the following limited warranty in accordance with the provisions below to each original retail purchaser of HARDI® new equipment of its own manufacturer, from an authorized HARDI® dealer, that such equipment is at the time of delivery to such purchaser, free from defects in material and workmanship and that such equipment will be warranted for a period of one year from the date of delivery to the end user providing the machine is used and serviced in accordance with the recommendations in the Operator's Manual and is operated under normal farm conditions.

1. This limited warranty is subject to the following exceptions:
 - a)Parts of the machine not manufactured by HARDI®, (i.e. engines, tires, tubes, electronic controls, and other components or trade accessories, etc.) are not covered by this warranty but are subject to the warranty of the original manufacturer. Any claim falling into this category will be taken up with the manufacturer concerned.
 - b)This warranty will be withdrawn if any equipment has been used for purposes other than for which it was intended or if it has been misused, neglected, or damaged by accident, let out on hire or furnished by a rental agency. Nor can claims be accepted if parts other than those manufactured by HARDI® have been incorporated in any of our equipment. Further, HARDI® shall not be responsible for damage in transit or handling by any common carrier and under no circumstances within or without the warranty period will HARDI® be liable for damages of loss of use, or damages resulting from delay or any consequential damage.
2. We cannot be held responsible for loss of livestock, loss of crops, loss because of delays in harvesting or any expense or loss incurred for labor, supplies, substitute machinery, rental for any other reason, or for injuries either to the owner or to a third party, nor can we be called upon to be responsible for labor charges, other than originally agreed, incurred in the removal or replacement of components.
3. The customer will be responsible for and bear the costs of:
 - a)Normal maintenance such as greasing, maintenance of oil levels, minor adjustments, etc.
 - b)Transportation of any HARDI® product to and from where the warranty work is performed.
 - c)Dealer travel time to and from the machine or to deliver and return the machine from the service workshop for repair.
 - d)Dealer traveling costs.
4. Parts defined as normal wearing items, (i.e. tires and V-belts) are not in any way covered under this warranty.
5. This warranty will not apply to any product which is altered or modified without the express written permission of HARDI® and/or repaired by anyone other than an Authorized Service Dealer.
6. Warranty is dependent upon the strict observance by the purchaser of the following provisions:
 - a)That this warranty may not be assigned or transferred to anyone.
 - b)That the Warranty Registration Certificate has been correctly completed by dealer and purchaser with their names and addresses, dated, signed and returned to the appropriate address as given on the Warranty Registration Certificate.
 - c)That all safety instructions in the operator's manual shall be followed and all safety guards regularly inspected and replaced where necessary.
7. No warranty is given on second-hand products and none is to be implied.
8. Subject to the following terms, conditions and contributions, HARDI® extends the warranty on polyethylene tanks (excluding fittings, lids and gaskets) to FIVE YEARS. To qualify for this extended warranty, the tank must be drained and flushed with fresh water after each day of use. HARDI®'s liability is limited to replacement of the tank, FOB our plant at no cost to the purchaser during the first twelve months; at 20% of the then current price during the second year ; at 40% during the third year ; at 60% during the fourth year; and at 80% during the fifth year. This five year extended warranty is subject, in each instance, to the tank being inspected and approved for replacement or repair by HARDI® personnel before HARDI® will accept any liability hereunder.

9 - Warranty

9. Subject to the following terms, conditions, contributions, HARDI® extends the warranty on HARDI® diaphragm pumps (excluding wearing parts such as diaphragms, valves, etc.) to FIVE YEARS. To qualify for this extended warranty, the pump must be drained and flushed with fresh water after each day of use. HARDI®'s liability is limited to replacement of defective parts, FOB our plant at no cost to the purchaser during the first twelve months after date of purchase, at 20% of the then current retail price during the second year ; at 40% during the third year ; at 60% during the fourth year ; and at 80% during the fifth year. This five year extended warranty is subject, in each instance, to the pump being inspected and approved for replacement or repair by HARDI® personnel before HARDI® will accept any liability hereunder.
10. HARDI® reserves the right to incorporate any change in design in its products without obligation to make such changes on units previously manufactured.
11. The judgement of HARDI® in all cases of claims under this warranty shall be final and conclusive and the purchaser agrees to accept its decisions on all questions as to defect and to the exchange of any part or parts.
12. No employee or representative is authorized to change this warranty in any way or grant any other warranty unless such change is made in writing and signed by an officer of HARDI® at it's head office.
13. Any warranty work performed which will exceed \$400.00 MUST be approved IN ADVANCE by the Service Manager.
14. Any pump replacement must be approved in advance by the Service Manager.
15. Claims under this policy must be filed with HARDI® within thirty (30) days of work performed or warranty shall be void.
16. Parts requested must be returned prepaid within thirty (30) days for warranty settlement.
17. Warranty claims must be COMPLETELY filled out properly or will be returned.

DISCLAIMER OF FURTHER WARRANTY

THERE ARE NO WARRANTIES, EXPRESSED OR IMPLIED, EXCEPT AS SET FORTH ABOVE. THERE ARE NO WARRANTIES WHICH EXTEND BEYOND THE DESCRIPTION OF THE PRODUCT CONTAINED HEREIN. IN NO EVENT SHALL THE COMPANY BE LIABLE FOR INDIRECT, SPECIAL OR CONSEQUENTIAL DAMAGES (SUCH AS LOSS OF ANTICIPATED PROFITS) IN CONNECTION WITH THE RETAIL PURCHASER'S USE OF THE PRODUCT.