

Table of Contents

Description	4
Operation Diagram	5
Connecting the Sprayer	5
Operation Instructions	6
Calibration	10
Nozzle Tables	16
Work Sheet	18
Safety Regulations	20
Preparing and Adding Chemicals	20
Maintenance	21
Adjustment of V-belts	21
Cleaning	22
Lubrication	23
Changing Valves and Diaphragms .	24
Winter Storage	25
Operational Problems	26
Technical Specifications	28
Optional Extras	28
Spare Part Drawings	29

COMBI SWING

Instruction book

674908-GB-86/8



Description

The HARDI NK-COMBI-3 turnable mistblower is mounted on the tractor three point linkage and consists of pump, 600 l tank with frame, operation unit, P.T.O. shaft, and hydraulically operated blower unit with 3-way asymmetric spout system.

The construction of the diaphragm pump is simple, with easily accessible diaphragms and valves. The construction ensures that the spray does not get in contact with the vital parts of the pump

The tank is made of highly impact-proof and chemical resistant polyethylene and has an appropriate design with no sharp edges. This means an easy cleaning.

The BK 180 K operating unit consists of units: pressure agitator, safety valve, on/off function, pressure filter with pressure gauge, distributing valves and pressure compensator.

The blower unit is equipped with a hydraulic motor which directs the spout 180 degrees horizontally, and a double-acting hydraulic cylinder can turn the spout 60 degrees vertically in order to alter the air stream direction of the spout during spraying.

The blower is a centrifugal blower. A strong air hose connects the blower housing with the spout. The exhaust area of the blower casing is divided into 3 spouts and in each spout opening nozzles are placed which measures, atomizes, and distributes the spray liquid in the air stream.

On the side of the tank are further mounted a foot board and a bracket for possible mounting of a hose reel.

Fitted on the frame is an identification plate that indicates model description, year of production and range number plus country of origin.

Operating Diagram

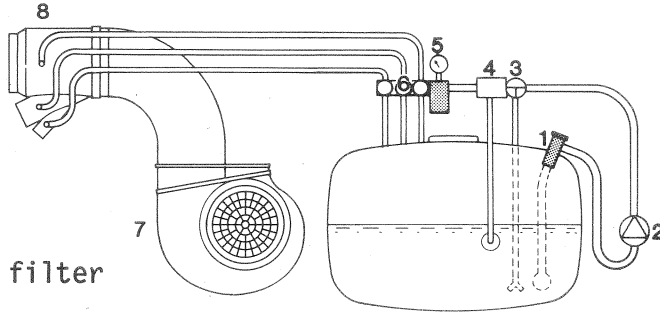

1. Suction filter
2. Pump
3. Pressure agitation
4. Operating unit
5. Pressure filter with pressure gauge
6. Distribution valve with pressure equalization
7. Blower with air hose
8. Adjustable spout

Connecting the Sprayer

When mounting the sprayer on the tractor, the length of the P.T.O. shaft should be checked, and if necessary, shortened.

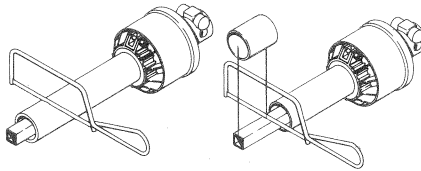

The sprayer is designed for three-point suspension and equipped with 28 mm pivots (category II).

Hydraulic connection needs a double outlet for the hydraulic adjustment of the spout. Please be aware of the fact that the hydraulic system requires an oil capacity of approx. 3 litres, and a minimum pressure of 130 bar.



Operating Instructions

Operating of the spouts

WARNING:



TESTING OF THE HYDRAULIC SYSTEM SHOULD BE DONE VERY CAUTIOUSLY; THERE MAY BE AIR IN THE SYSTEM AND THIS MAY CAUSE VIOLENT MOVEMENTS OF THE BOOM. THEREFORE TAKE CARE THAT NO PERSONS OR OBJECTS ARE HURT OR DAMAGED IN THE PROCESS OF TESTING.

THE SPOUT IS ADJUSTED USING THE CONTROL LEVER OF THE TRACTOR.

On the front frame of the sprayer is placed a change-over valve for pre-setting of the turning and tilting functions of the spout.

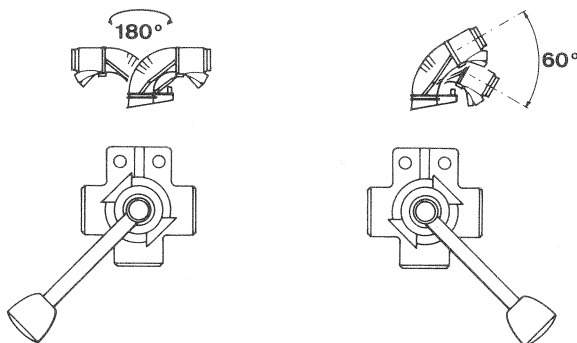

The turning function is controlled by a hydraulic motor turning the spout max. 180 degrees. The tilting function is controlled by a double-acting hydraulic cylinder which can be set in two positions:

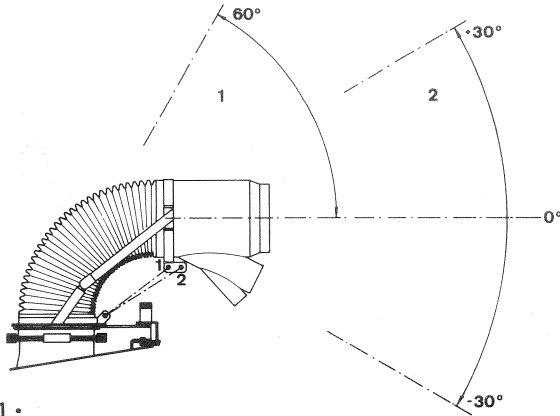

Position 1:

The cylinder is placed in the inner hole and the spout can then tilt 60 degrees up from horizon.

Position 2:

The cylinder is placed in the outer hole and the spout can then tilt 30 degrees up and down from horizon.

Adjustment to the Air Pressure in the Pulsation Damper

The air pressure in the pulsation damper is preset at the factory to 2 bar, to cover spray working pressures between 3 and 15 bar. When using spray pressures outside this range, the air pressure should be adjusted as shown in the diagram.

bar	bar
15 - 3	0 - 1
3 - 15	1 - 3
15-25	3 - 4





Operating of the operating unit

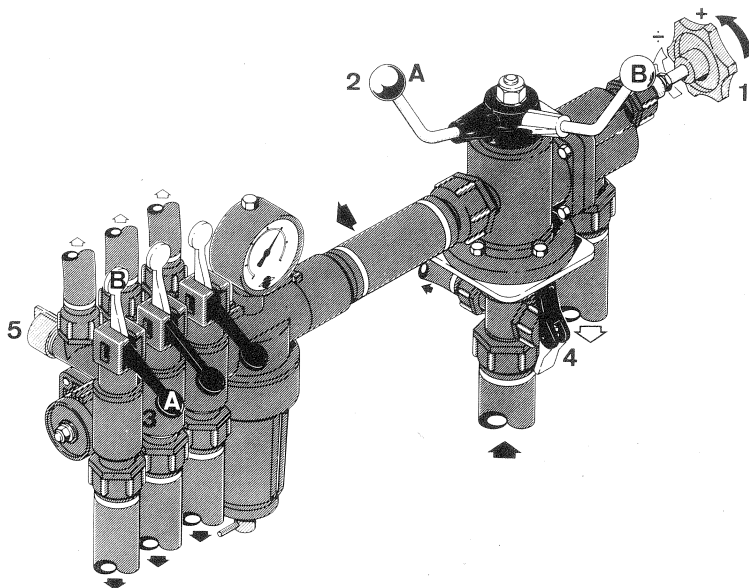

1. Open or close lever (4) depending on whether pressure agitation is required.
2. Main lever (2) is put in pos. A (spraying position).
3. All handles (3) on the distribution valve are put in position A (spraying position).
4. With the tractor in neutral the P.T.O. is adjusted to 540 r/min because of the output of the blower.

Adjustment of pressure equalization on the distribution with the following procedure:

5. Turn the pressure regulating handle (1) until the required pressure shows on the pressure gauge.
6. The first handle (3) on the distribution valve is put into position B (closed position).

7. Using the adjusting screw (5) the pressure is adjusted until the same pressure as that chosen is shown. (right = higher pressure, left = lower pressure).



8. The other section on the distribution valve is adjusted in the same way.

NB: ADJUSTMENT OF THE PRESSURE EQUALIZATION WILL ONLY BE NEEDED IF CHANGING TO NOZZLES OF OTHER CAPACITIES.

9. Operating the control unit whilst spraying:

In order to stop the entire liquid supply to the spout, turn operation handle (2) to position B. This returns the whole of the pump's output to the tank through the return system. In order to close part of the spout turn handle (3) of the distribution valve to position B (off position) for the part or parts to be closed. The pressure equalization ensures that the pressure does not rise on the spout that remains open.

Adjustment of V-Belt

NB: Remember to control and tighten the belts after few hours of operation.



Disengaging the fan

Spraying with lance/pistol or tank filling only needs the pump operating, and it is therefore practical to disengage the fan.

The handle for engaging/disengaging the fan is operated through the hole in the middle of the air intake on the blower unit. Pull handle OUT to disengage fan. Push handle IN to engage fan.

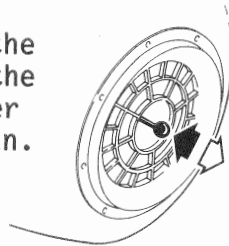

IMPORTANT:

BOTH PUMP AND FAN WHEEL SHOULD BE STATIONARY WHEN ENGAGING/DISENGAGING FAN.



Operating the Drain Valve on tank

To open : Turn to the left
To close : Turn to the right

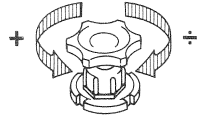

Operating the Drain Valve on Pressure Filter

To open : Turn to the right
To close : Turn to the left

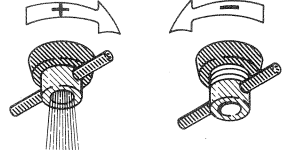

Calibration

Determination the size of nozzles

By use of different sizes of nozzles and combinations with the different coloured swirls, the drop size that suits the various spray jobs can be obtained.

Nozzle 1999 can be combined with blue, grey, black, or white swirl. With blue swirl you obtain the smallest drop size, and the white swirls you obtain the largest drops. With regard to drop size and nozzle combinations, a maximum of 2 colours should be used. Only blue-grey, grey-black or black-white should be combined.

It should be remembered when choosing the nozzles that pressure agitation uses 5 to 10% of the pump's capacity.

Most often calculations are done km/h, nozzle size, pressure and l/ha to ensure exact doses in the individual crop.

When calculating use this formula:

$$\frac{\text{Spray width (m)} \times \text{l/ha} \times \text{km/h}}{600 \text{ (factor)}} = \text{l/min}$$

As a rule, a nozzle combination must be chosen to give the following liquid distribution.

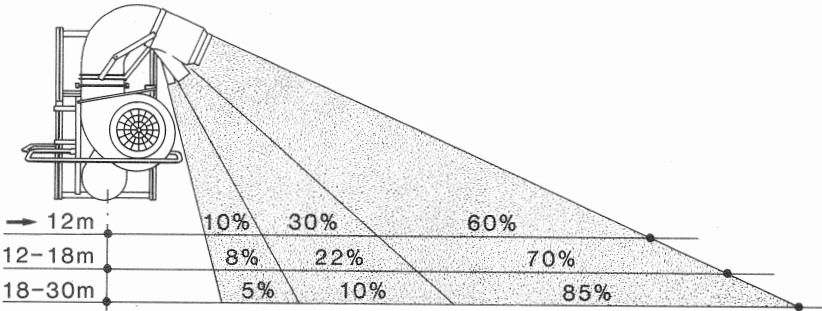

Individual spraying examples and nozzle combinations are given on pages 14 and 15.

Example of the calculation:

Row width 20 m
 Required application rate 400 l/ha
 Forward speed 3 km/h

Note that dense foilage and wide row widths require slow speeds.

Total output of all nozzles:

$$20 \text{ m} \times 400 \text{ l/ha} \times 3 \text{ km/h} = 40 \text{ l/min}$$

 600 (factor)

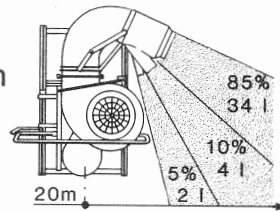



From the tables on pages 16 and 17 choose the nozzle size, swirl and pressure to give the desired distribution.

Position	Nozzle: 1999 Swirl: G= Gray	Actual		Ideal Total	
		l/min 10 bar	Spout Total		
	1	35-G	4.80	31.68	34.00
	2	30-G	4.48		
	3	30-G	4.48		
	4	30-G	4.48		
	5	30-G	4.48		
	6	30-G	4.48		
	7	30-G	4.48		
	8	24-G	3.57	3.57	4.00
	9	-	-		
	10	-	-		
	11	-	-		
	12	16-G	2.33	2.33	2.00
				37.58	40.00

It is necessary to increase the pressure to 11.3 bar to obtain 40 l/min.

To ensure correct pressure and output for the nozzles chosen, 200 l of clean water should be sprayed out when the sprayer is stopped. Example:



$$\frac{200 \text{ l}}{40 \text{ l/min}} = 5 \text{ min.}$$

In case the spray liquid is viscous a higher pressure may be necessary.

Do not forget to ensure a correct forward speed. It is extremely important to apply a small rate of volume.

The nozzle/swirl tables on pages 16 and 17 and the working table on pages 18 and 19 can be used as appropriate calculations.

Control of spraying speed

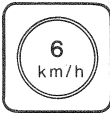

The tractor speedometer indicates speeds at 540 r/min for all gears. However, this is rarely accurate enough and needs checking.

Tractor speed can be determined between 2 points in the following way:

$$\frac{\text{Metre driven} \times 3.6}{\text{Time taken in seconds}} = \text{km/h}$$

Example:

Distance	100 m	$\frac{100 \times 3.6}{120}$	=	3 km/h
Time	120 s			

Spraying examples

Working-length (m)	l/ha	km/h	Total ideal l/min	Nozzle set	Actual total l/min	bar
10	200	3.0	10	1	9.85	6
		6.0	20	2	22.91	5
	400	3.0	20	2	22.91	5
		6.0	40	3	39.04	10
	600	3.0	30	3	29.76	5
		4.5	45	3	39.04	10
15	200	2.0	10	4	10.95	6
		4.0	20	5	20.57	5
	400	2.0	20	5	20.57	5
		4.0	40	6	35.18	10
	600	2.0	30	6	27.25	6
20	200	1.5	10	7	10.15	5
		3.0	20	8	21.11	10
	400	1.5	20	8	21.11	10
		3.0	40	9	37.58	10
	600	1.5	30	9	29.05	6
25	200					
		2.5	20.8	8	21.11	10
	400					
		2.5	41.6	9	37.58	10
30	200					
		2.0	20	8	21.11	10
	400					
		2.0	40	6	37.58	10

Nozzle Combination/Set Examples

Position	Ceramic Nozzle: 1999 – Swirl: B = blue G = gray											
	up to 12 m			12 m to 18 m			18 m to 30 m					
	1.	2.	3.	4.	5.	6.	7.	8.	9.			
1*	20-B	20-G	30-G	14-G	24-G	30-G	-	30-G	35-G			
2	18-B	18-G	24-G	10-G	20-G	24-G	14-G	16-G	30-G			
3	18-B	18-G	24-G	10-G	20-G	24-G	14-G	16-G	30-G			
4	18-B	18-G	24-G	10-G	20-G	24-G	14-G	16-G	30-G			
5	18-B	18-G	24-G	10-G	20-G	24-G	14-G	16-G	30-G			
6	18-B	18-G	24-G	10-G	20-G	24-G	14-G	16-G	30-G			
7	18-B	18-G	24-G	10-G	20-G	24-G	14-G	16-G	30-G			
8*	16-B	18-G	24-G	12-B	12-G	14-G	10-G	14-G	24-G			
9	14-B	16-G	20-G	8-B	10-G	12-G	-	-	-			
10	14-B	16-G	20-G	8-B	10-G	12-G	-	-	-			
11	14-B	16-G	20-G	8-B	10-G	12-G	-	-	-			
12	16-B	18-G	24-G	12-B	12-G	14-G	8-B	10-G	16-G			

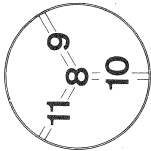
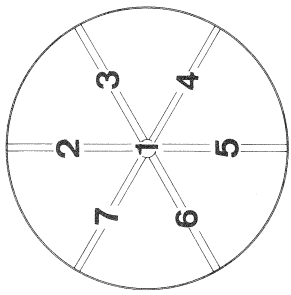

* Larger nozzle generally used



Hollow cone nozzle 1999 with blue swirl, 370156

Nozzle no.	Capacity l/min						
	bar						
	1	2	3	5	6	10	15
1999-08	0.22	0.31	0.38	0.49	0.54	0.70	0.85
1999-10	0.25	0.36	0.44	0.57	0.62	0.81	0.99
1999-12	0.28	0.40	0.49	0.63	0.69	0.89	1.09
1999-14	0.30	0.43	0.53	0.68	0.74	0.96	1.18
1999-16	0.32	0.46	0.56	0.73	0.80	1.03	1.26
1999-18	0.35	0.49	0.60	0.77	0.85	1.10	1.34
1999-20	0.38	0.54	0.66	0.85	0.93	1.21	1.48



Hollow cone nozzle 1999 with gray swirl, 370134

Nozzle no.	Capacity l/min						
	bar						
	1	2	3	5	6	10	15
1999-08	-	0.49	0.60	0.77	0.85	1.10	1.34
1999-10	-	0.61	0.75	0.96	1.06	1.36	1.67
1999-12	0.54	0.77	0.94	1.22	1.33	1.72	2.11
1999-14	0.65	0.92	1.12	1.45	1.59	2.06	2.52
1999-16	0.73	1.04	1.28	1.65	1.80	2.33	2.85
1999-18	0.88	1.25	1.53	1.98	2.16	2.80	3.42
1999-20	0.95	1.34	1.64	2.12	2.32	3.00	3.67
1999-24	1.13	1.60	1.96	2.53	2.77	3.57	4.38
1999-30	1.41	2.00	2.45	3.16	3.46	4.48	5.48
1999-35	1.52	2.15	2.63	3.40	3.72	4.80	5.88

$$\left(\frac{\text{NEW FLOW}}{\text{OLD FLOW}} \right)^2 \times \text{OLD PRESSURE} = \text{NEW PRESSURE}$$

1. ON/OFF switch **A** is set towards green (ON).
2. The distribution valves switches **V** are set towards green (ON).
3. Pressure regulation switch **C** is activated until knob **3**, stops rotating (minimum pressure).
4. Put the tractor in neutral and set the P.T.O. revolutions to 540 r/min.
5. From a given forward speed in a gear and the nozzles chosen, the desired pressure on the pressure gauge is set by means of the pressure regulation switch **D**.

NOTE: Maximum pressure is 25 bar. Do not operate over 25 bar.

ADJUSTMENT OF PRESSURE EQUALIZATION

6. Close the first distribution valve switch **V**.
7. Turn the adjusting screw **1** until the pressure gauge again shows the same pressure.
8. Adjust the other section in the same manner.

NOTE: Hereafter adjustment of pressure equalization will only be needed if you change to nozzles of other capacities.

Operating the unit whilst spraying

To stop the liquid flow to both sides of the blower, switch ON/OFF **A** to OFF position. This returns the pump output to the tank through the return system.

If you want to spray on one side only, switch the relevant distribution valve **V** to OFF position for the section to be closed. The pressure equalization ensures that the pressure does not rise in the section which remains open.

In case of power failure it is still possible to activate all functions of the operating unit. To operate manually, first disconnect the multiplug and then turn the relevant knob.

When the sprayer is put aside, the control box and the multiplug must be protected against moisture and dirt. A plastic bag may be used to protect the multiplug.



WORK SHEET

$$\frac{l/ha \times km/h \times \text{working length (m)}}{600} = l/min$$

$$\frac{600 \times l/min}{\text{working length (m)} \times km/h} = l/ha$$

$$\frac{600 \times l/min}{l/ha \times \text{working length (m)}} = km/h$$

Working-length (m)	l/ha	km/h	Total ideal l/min	Nozzle set	Actual total l/min	bar

Position

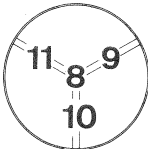
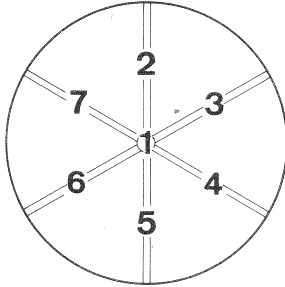

Ceramic nozzle: 1999 -
Swirl colour: B = blue, G = gray,
BK = black, W = white

	10.	11.	12.	13.	14.
--	-----	-----	-----	-----	-----

1					
2					
3					
4					
5					
6					
7					
8					
9					
10					
11					
12					



S4/S6 boom

1. The LP S4 boom is unfolded manually. The TP S4 or S6 boom is first raised clear of the transport brackets via the single-acting hydraulic and then unfolded via the double-acting hydraulics.

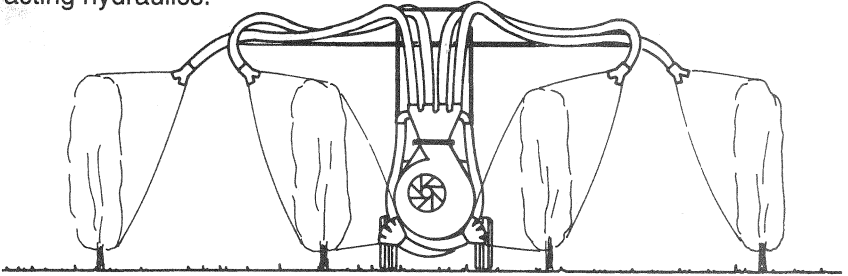
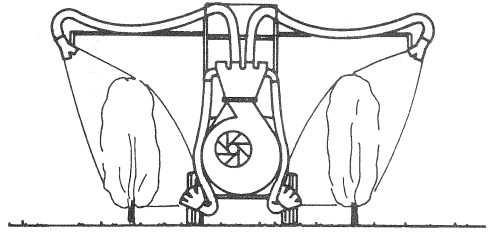

2. Adjust the boom height and spouts so that they point toward the foliage. For LP S4, cautiously loosen counter nuts **A** and bolts **B** on both sides. Boom can now be raised or lowered. Retighten bolts and counter nuts.

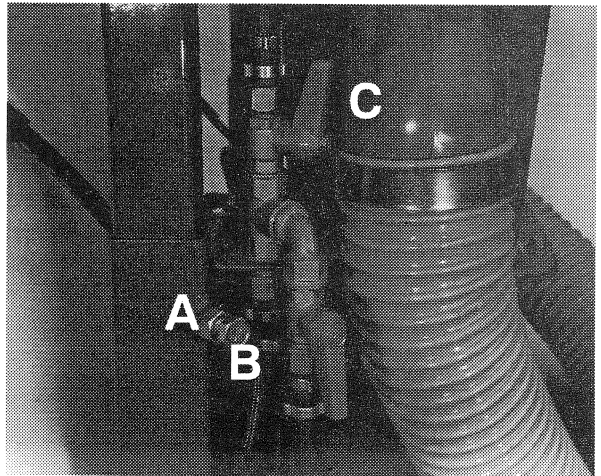

The S6 boom is designed for

spraying larger vines or vines in wider rows more effectively.

3. Engage the fan, set the P.T.O. revolutions to 540 r/min and check the spout positions by spraying. Liquid flow to the spouts can individually be turned off. Valves **C** are located just in front of the blower manifold.

Powdered crop protection chemicals should be dissolved or "creamed" in water before adding.



Guidance mentioned on the chemical packs should be observed very strictly.

Maintenance

In order to get years of trouble-free operation from the sprayer, the rules below should be adhered to:

Adjustment of V-Belt

BLOWING UNIT

To alter the tension of the V-belts on the blower unit, nuts A on the blower suspension are loosened, and the belt tension is adjusted by the adjusting bolts B.

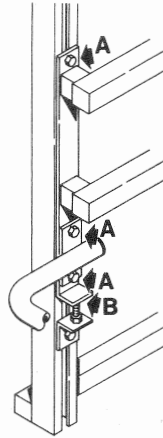

PUMP

The pump drive V-belts are correctly tensioned by using the pump adjusting bolts.

TURNABLE SPOUT

Adjustment of the V-belt is made by loosening bolt C below the V-belt pulley. Adjust by means of nut D.

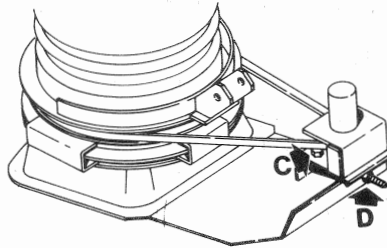

DO NOT FORGET TO TIGHTEN ALL BOLTS AFTER ADJUSTMENT

V-belt tension should be checked frequently.



Cleaning the Sprayer

During the spraying season the sprayer must also receive some maintenance. Cleaning is important. When changing from one chemical to another, in order to wash out the first chemical, add 1.5 kg of washing soda to 100 litres of water in the tank, start the pump and wash out the entire sprayer, including distribution pipes and nozzles. Spray out and then fill with clean water - spray out again.

After use, both sprayer and tractor should be washed down.

NB: Do not clean your sprayer where there is a risk of contaminating wells, streams, ponds, etc.



REMEMBER:

AN UNCLEANNED SPRAYER IS A HAZARD TO BOTH HUMANS AND LIVESTOCK.

THEREFORE, NEVER LEAVE A SPRAYER CONTAINING CHEMICALS ALONE.

FILTERS

Remember that cleaning also entails the cleaning of all filters. Clean the filters thoroughly on both suction and pressure side. Renew them if necessary.

NOZZLES

The user should always have extra nozzles in store so that waste of time may be avoided when spraying time and weather conditions are ideal.

Check and carefully clean all nozzles. Damaged nozzles dose incorrectly and should be changed immediately.

Lubrication

MAIN BEARINGS

Bearing housing on the main shaft of the sprayer and the blowing unit should be greased every 400 operation hour or at least once a season with ball bearing grease

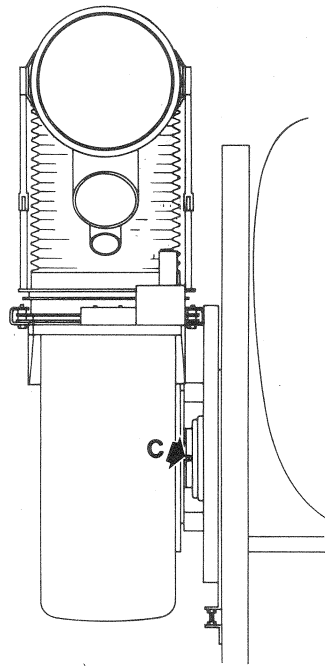
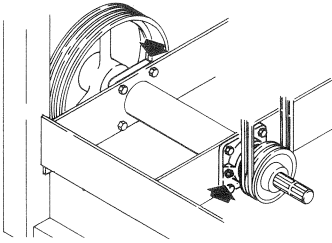

THE SPOUT

Grease A, B and C frequently. Rotate spout by hand when greasing C.

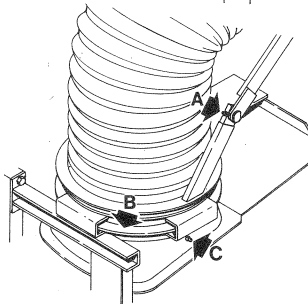

PUMP

Once or twice in the season, depending on how much the sprayer is used, it is recommended to lubricate the pump with ball bearing grease.

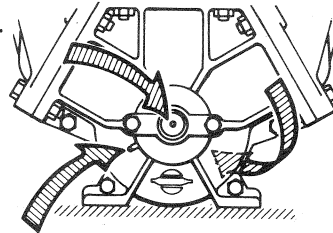

Lubrication points of the pump.



OPERATING UNIT

Regularly lubricate all moving parts of the operating unit, distributing valves, and possibly the filling valve.

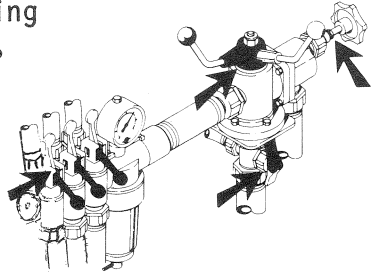

P.T.O. SHAFT

Lubricate the universal joints and the bearings with ball bearing grease each 12th working hour.

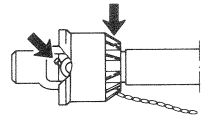

Changing of Valves and Diaphragms

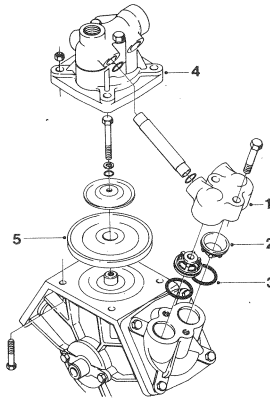

VALVES

Dismantle valve compartment (1). Before changing the valves (2) note the orientation of the valves so that they may be replaced correctly. It is recommended to use new gaskets (3) when changing or checking the valves.

DIAPHRAGMS

Remove the diaphragm cover (4) after having dismantled the valve compartment as indicated above. The diaphragm (5) may then be changed. If fluids have reached the crankcase it is strongly recommended to lubricate the entire pump with plenty of grease.

Winter Storage



When the spraying season is over you should devote some extra time to the sprayer, before it is put away for the winter.

ANTI-FREEZE PRECAUTIONS

If the sprayer is not stored in a frost-proof place you should take the following precautions: fill 10 litres of 33 per cent anti-freeze mixture in the tank and let the pump run a few minutes so that the entire system is filled. The pressure gauge is dismantled and stored in upright position.

HOSES

Check that none of the hoses are caught or have sharp bends. A leaky hose causes delay in the middle of spraying. Therefore, check all the hoses and change if there is any doubt about the durability.

NOZZLES

Remove all nozzles, swirls, etc. Clean and store in a suitable place.

PAINTING

Some chemicals are very rough on paints. It is therefore well advised to remove rust, if any, and then touch up the paint.

OPERATING UNIT

Make sure that the pressure regulating handle is turned anti-clockwise to its end point. Distribution valve taps should be in closed position, as this relieves the pressure on the springs. Start up problems can then be minimized.





THE TANK

Ensure that the tank is cleaned out before adding the anti-freeze solution and that no chemical residue is left behind. Chemical residues can affect the life of the tank.

P.T.O.

Ensure that the shaft cover and guards are intact, replace where necessary.



Operational problems

In case where breakdowns have occurred the same factors always seem to come into play:

1. Even a minor leak on the suction side of the pump will reduce the capacity of the pump or stop any suction at all.

The reason may often be found in joints, defective hoses or lacking gaskets. Therefore, check all joints on the suction side.

2. A clogged up suction filter will prevent aspiration so that the pump does not operate satisfactorily. A clogged up pressure filter will result in falling pressure at the nozzles.

It is therefore important to keep all filters clean.

3. Foreign bodies stuck in the pump valves with the effect these cannot close tightly against the valve seat will cause the pump to work unsatisfactorily.

Therefore, always take care that the filters are whole so that the pump cannot suck in impurities.

4. Where the pump has been serviced and reassembled incorrectly, it will not pump at all if the valve springs face against the water flow on suction side. If the valve springs face against the water flow on the pressure side, then the cylinder head will be blown off or the pump casing will crack.



5. Insufficiently closed diaphragm cover will allow the pump to suck air with the resulting reduced or no capacity.

Therefore, take care always to tighten diaphragm covers and valve compartments when these have been dismantled.

6. Worn diaphragm will reduce the pump capacity, but it is only necessary to replace the diaphragm when it is worn through. When this occurs liquid will run out of the drain hole in the base of the pump casing.

7. When the pump cannot suck in water it cannot supply water on the pressure side.

The reason for reduced pressure or capacity on the pressure side may, therefore, just as often be found on the suction side of the pump.

8. Reduced or lack of pressure may be caused by insufficient spring tension or worn valve cone on the pressure compensation of the control unit.

9. Loose or partly loose V-belts may cause a lower number of revolutions of the pump.

10. If the hydraulics do not function it may be due to dirt in the inlet nipples, or too little oil in the hydraulic oil tank for the tractor, or the tractor does not provide enough pressure (min. 130 bar).

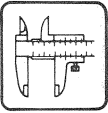

Technical Specifications

Pump Model	Pump capacity l/min.	Max.pump pressure bar	Air velocity m/s	Air quantity m ³ /h	Max.spray range m	Power-consumption kW	Dimensions mm l x W x h	Weight kg
1301	116	15	50	20.000	28	24	1400 x 2000 x 1950	450

All capacities are indicated at 0 bar and 540 r/min.

The filling capacity of the pumps is 80-85% of the capacity indicated depending on the suction head.

The power consumption is stated at a working pressure of 10 bar.

The weight is stated for an empty tank.

Air quantity is stated at 540 r/min.

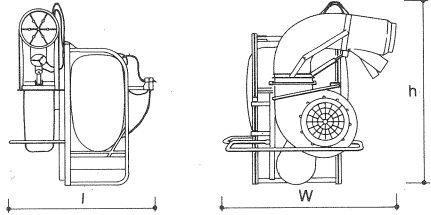

Optional Extras

Remote Control

Spray Guns

Clean Water Tank

Hose Reel

Ask your HARDI dealer to show you our extra equipment

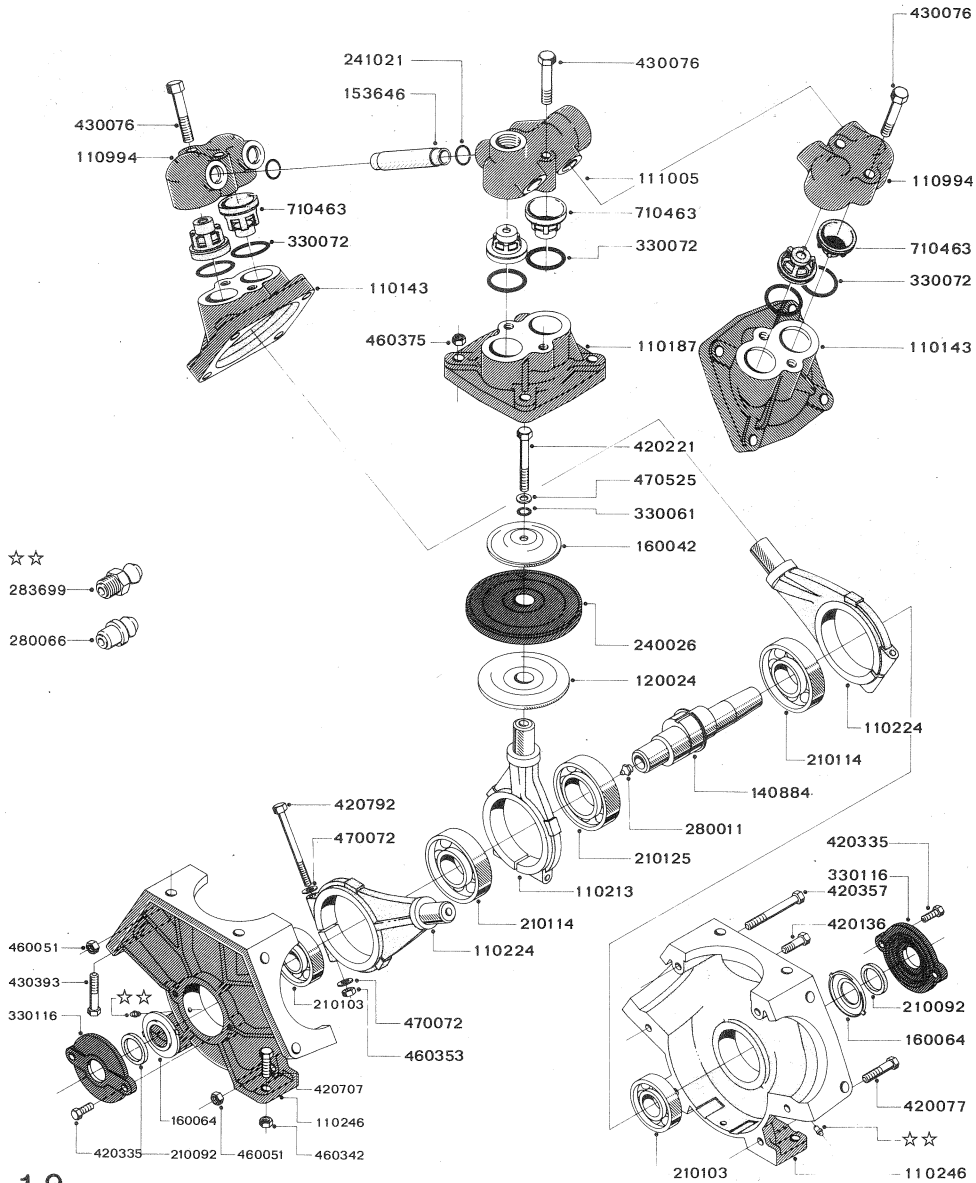

A 19
 2-1-85 1301

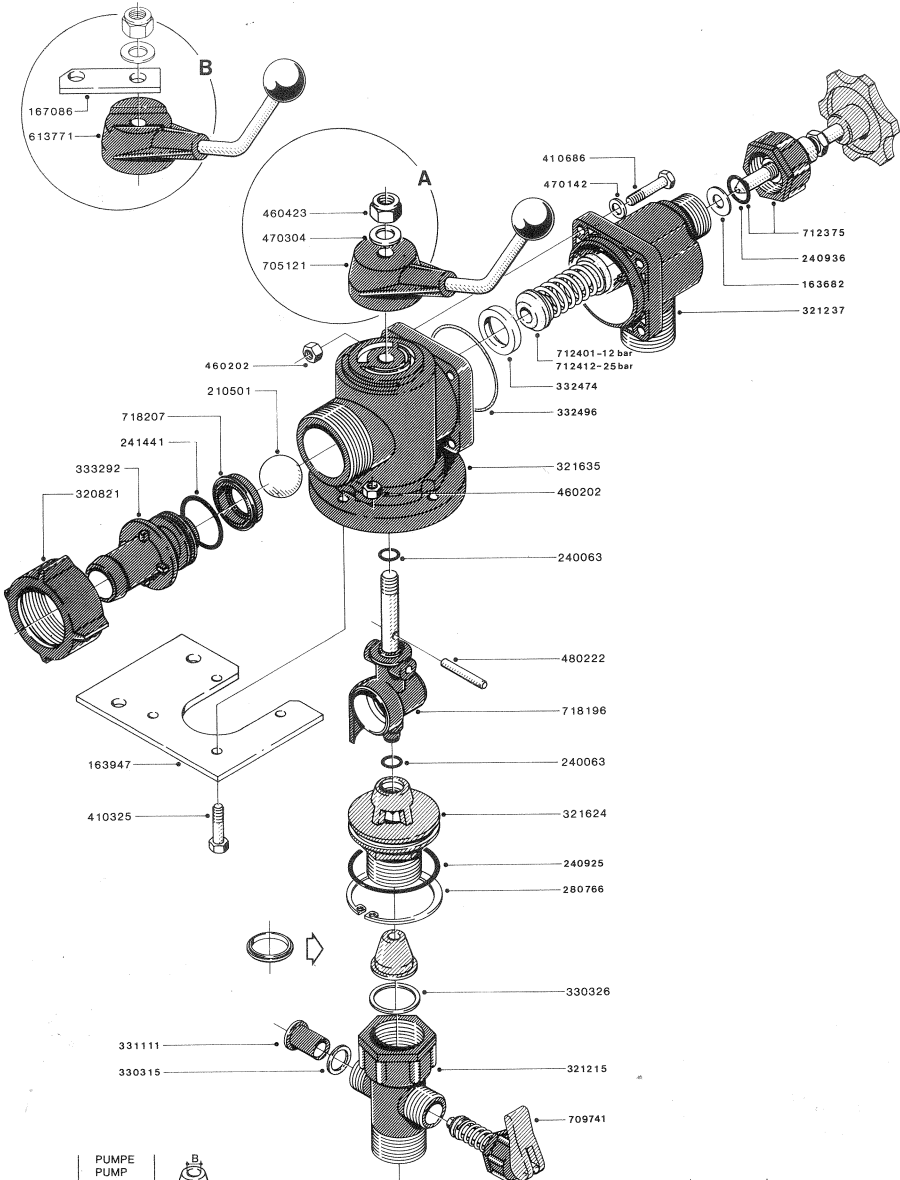

PUMPE PUMP POMPE PUMPE BOMBA		B mm	FARVE	COLOUR	COULEUR	FARBE	COLOR	
600	333314	5,2	BLÅ	BLUE	BLEU	BLAU	AZUL	
1200	333325	7,3	RØD	RED	ROUGE	ROJO	ROJO	
1301	333336	8,7	HVID	WHITE	BLANC	WEISS	BLANCO	
361 HT	333347	9,6	ORANGE	ORANGE	ORANGE	ORANGE	ANARANJADO	
361	333351	10,5	SORT	BLACK	NOIR	SCHWARZ	NEGRO	
320 HT	333362	6	GRØN	GREEN	VERT	GRÜN	VERDE	
460								145305

B15
BK 180K

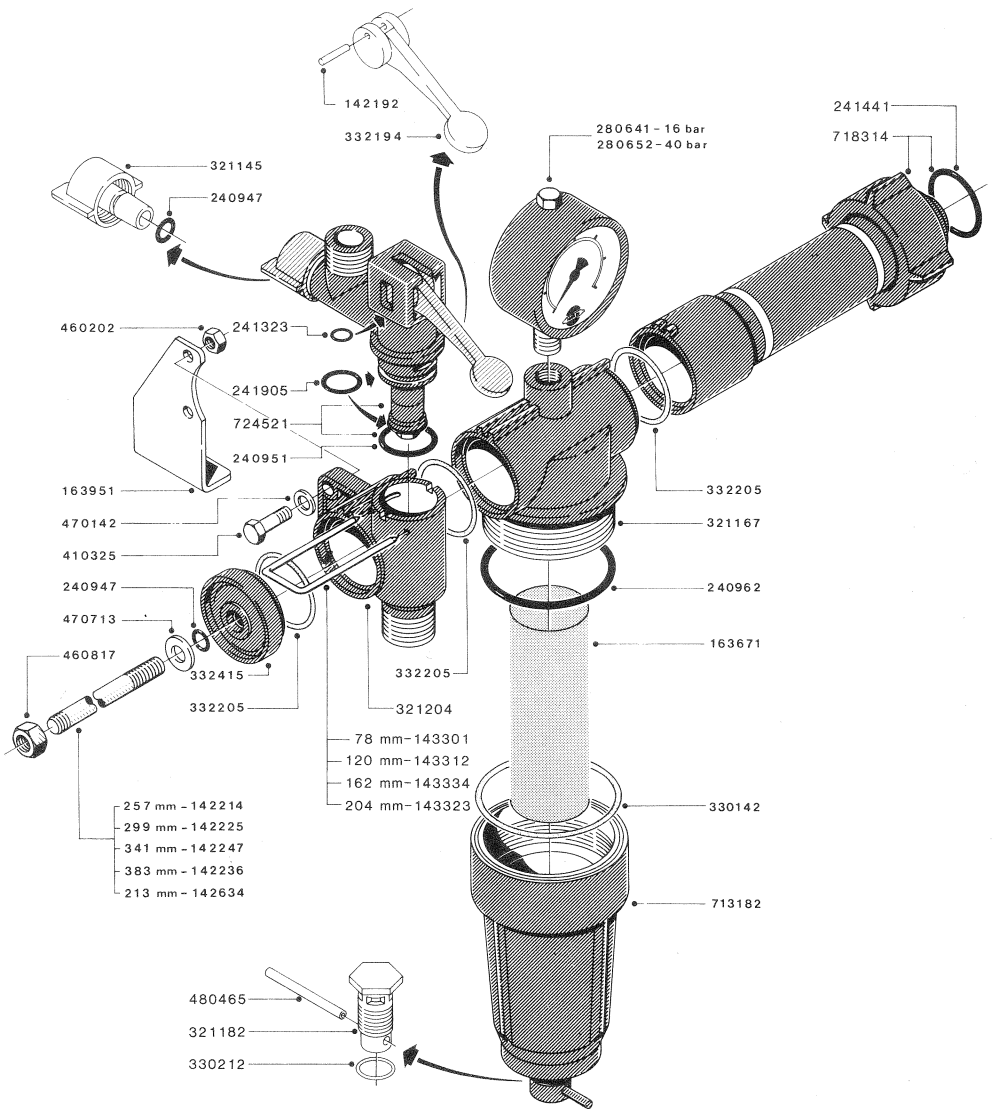

B16

14-10-83

BK180K

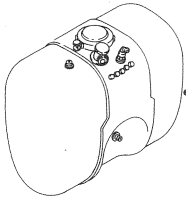

NK/LX 713027
LY 724709

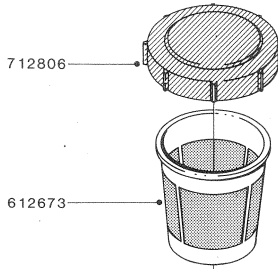

712806

612673

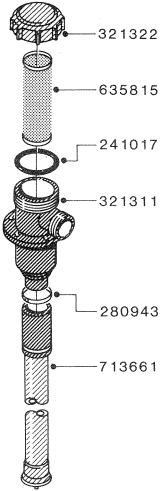

321322

635815

241017

321311

280943

713661

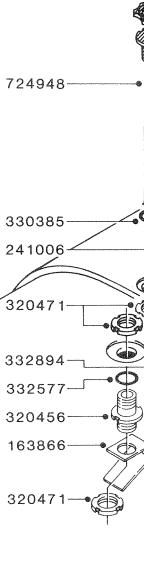

724948

330385

241006

320471

332894

332577

320456

163866

320471

322060

242008

322059

240925

322061

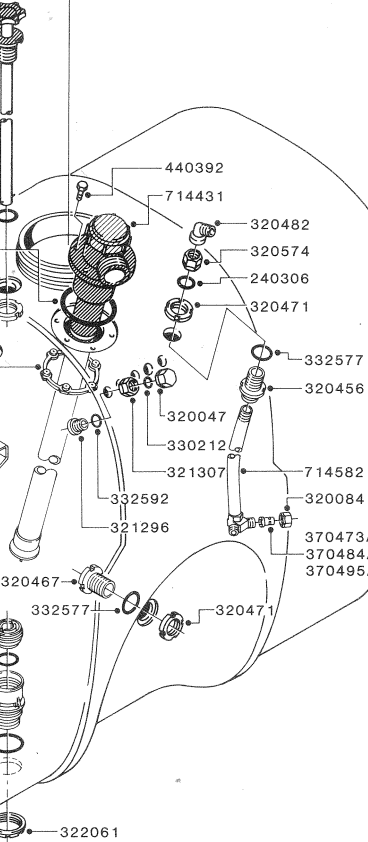

440392

714431

320482

320574

240306

320471

332577

320456

320047

330212

321307

332592

321296

320467

332577

320471

320471

320471

320471

320471

320471

320471

320471

320471

320471

370473/5066-2
370484/5066-2,5
370495/5066-3

C 103 2-1-85
NK/LX/LY 600

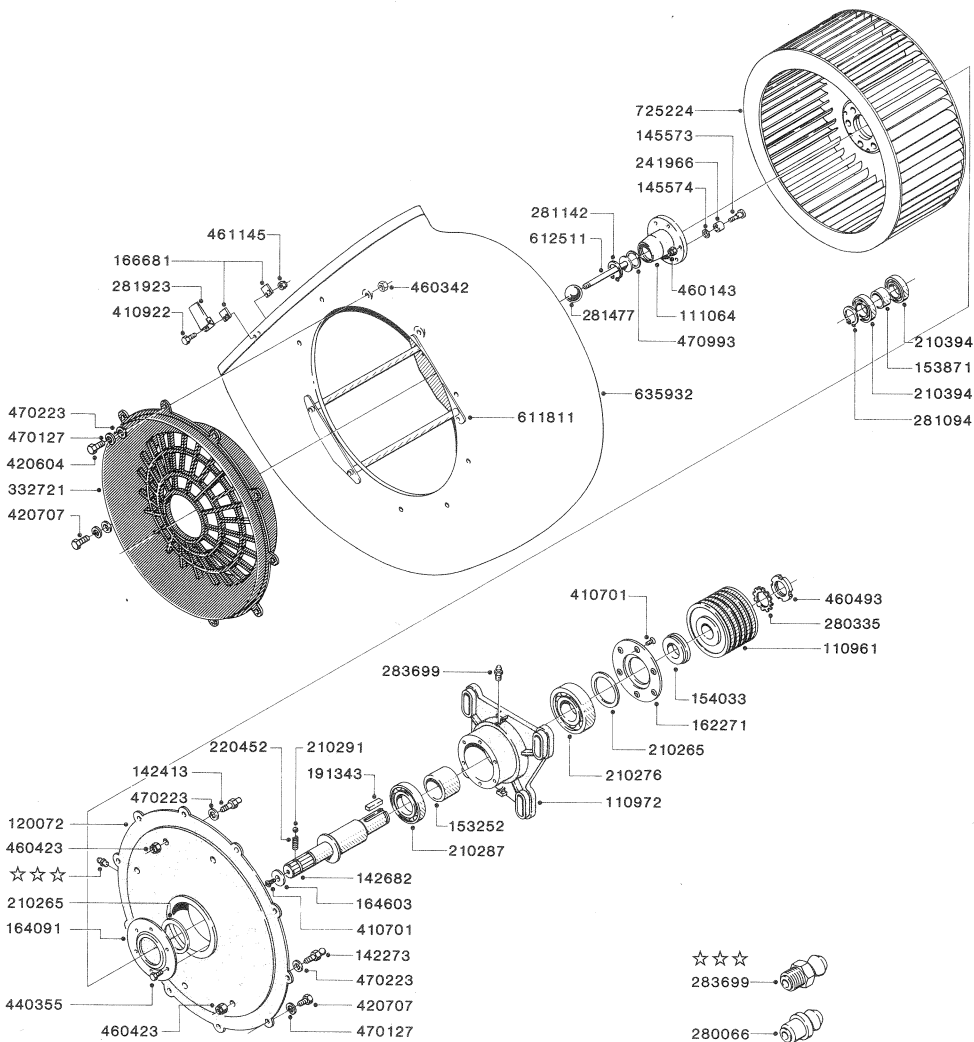

1-4-85

F28

Notes: