



The Sprayer

Operator's Manual

CONTROLLER HC5500 SPRAYBOX III

Instruction book - sw 5.XX

67026203 - Version 1.00

US - 08.2020

CONTROLLER HC5500 SPRAYBOX III

Instruction book - sw 5.XX

67026203 - Version 1.00

US - 08.2020

1 - Welcome	
Welcome letter	7
2 - Safety Notes	
Operator Safety	9
Symbols	9
Precautions	9
3 - Description	
General info	11
Controller features	11
Glossary and pictorial symbols	12
System description	13
Main components	13
DynamicFluid4 pressure regulation	14
Keys and Display	15
General description of controller keys	15
General description of display	17
General description of switches for Spray Box III	18
General keystrokes, example	19
Menu tree	20
4 - System setup	
Tractor installation	21
Control units	21
Installation of control unit brackets	21
Power supply	22
Printer	22
Speed sensor for the sprayer	23
Speed sensor for the tractor	23
Foot pedal remote	24
Initial system start-up	24
Screen contrast adjustment	24
Daily settings	25
System start-up	25
5 - Menu 1, Daily Settings	
Menu 1.1 Volume rate	27
How to change the volume rate	27
How to read the preset volume rate	28
How to use manual dosage	28
Menu 1.2 Tank contents	29
How to change the tank contents	29
Menu 1.3 Select register	30
How to select a register and its data	30
6 - Menu 2, Setup	
Menu 2.1 Display Readout	31
General info	31
Example of readout	31
Menu 2.1.1 Program : Actual	31
Menu 2.1.2 Flow rate	31
Menu 2.1.3 Optional sensor	32
Menu 2.1.4 Time	32
Menu 2.1.5 Work rate	32
Menu 2.1.6 Volume rate	32
Menu 2.1.7 Tank contents	32
Menu 2.1.8 Speed	33
Menu 2.1.9 Volume : Area	33

Table of Contents

Menu 2.1.10 Active boom size	33
Menu 2.2 Auto Functions	34
Menu 2.2.1 Auto ON/OFF	34
Menu 2.2.2 Foam marker (optional)	34
Menu 2.3 VRA/Remote	35
VRA / Remote Control/ AutoSectionControl	35
Menu 2.4 Set Clock	36
How to set clock	36
Menu 2.5 Alarms	37
How to set up alarms	37
Menu 2.5.1 Volume rate	37
Menu 2.5.2 Tank contents	37
Menu 2.5.3 Spray pressure	37
Menu 2.5.4 Fan speed	38
Menu 2.5.5 Speed	38
Menu 2.5.6 Audio level	38
Menu 2.5.7 Sections off	39
Menu 2.6 Register Names	40
How to name the registers	40
Menu 2.6.XX Copy name?	40

7 - Menu 3, Calibration

Menu 3.1 Speed calibration	41
Menu 3.1.1 Sprayer	41
Menu 3.1.1.1 Constant	42
Menu 3.1.1.2. Practical	42
Menu 3.2 Flow calibration	43
Which method to use	43
Menu 3.2.2 Nozzle method	44
Menu 3.2.3 Tank method	45
Menu 3.3 Boom	46
Menu 3.3.1 Width	46
Menu 3.3.2 Number of sections	46
Menu 3.3.3 Nozzles/section	46
Menu 3.3.4 End nozzles	46
Menu 3.4 Regulation constant	47
General info	47
Menu 3.4.1 Flow sensor restriction	47
Menu 3.4.2 Simulated speed value	48
Menu 3.4.3 Nozzle size flow at 40 psi	49
Menu 3.4.4 Reserved	49
Menu 3.4.5 Type of nozzle	49
Menu 3.5 Tank gauge	50
General info	50
Menu 3.5.1 Adjustment	50
Menu 3.5.2 Calibration	51
Menu 3.5.3 Tank selection	52
Menu 3.5.4 Offset empty	52

8 - Menu 4, Toolbox

Menu 4.1 Measure	53
Tripmeter	53
Menu 4.2 Service interval	54
Menus and intervals	54
Service interval reset	54
Menu 4.3 Stopwatch	55
Use as timer	55
Menu 4.4 Alarm clock	56
How to use the alarm clock	56

Table of Contents

Menu 4.5 Test	57
How to make equipment test	57
Menu 4.6 Speed simulation	59
How to use speed simulation	59
9 - Menu 5, Logbook	
Menu 5.1 Print	61
What you can print	61
Menu 5.2 Data dump	62
How to dump data	62
10 - Maintenance	
Off-season maintenance	63
Off-season storage	63
11 - Fault finding	
Emergency Operation	65
In an emergency situation	65
Operational Problems	66
Operational faults	66
Mechanical faults	66
Operation when a sensor fails	67
Fluid system test	68
Alarm list	69
12 - Testing and fine tuning	
Testing and fine tuning	71
Fine tuning the flow constant - PPU	71
Testing flow sensor	72
Testing speed sensor	72
13 - Technical specifications	
Specifications	73
Electrical properties	73
Flow ranges for flow sensors	73
Baud rate	73
Materials and Recycling	74
Disposal of electronics	74
Packaging information	74
Notes	75
Table for recording values	75
14 - Warranty	
Warranty policy and conditions	77
Index	
Index	79

Table of Contents

Welcome letter



Dear Owner,

Thank you for purchasing a HARDI® product and welcome to the ever-increasing family of HARDI® sprayer owners.

Our sprayers and accessories are rapidly becoming a familiar sight on North American farms. We believe that this results from growers becoming increasingly conscious of crop protection input costs and the vital need for cost effective spray application equipment.

Please take the time to thoroughly read the Operator's Manual before using your equipment. You will find many helpful hints as well as important safety and operation information.

Some of the features on your HARDI® sprayer were suggested by growers. There is no substitute for "on farm" experience and we invite your comments and suggestions. If any portion of this instruction book remains unclear after reading it, contact your HARDI® dealer or service personnel for further explanation before using the equipment.

For Product, Service or Warranty Information:

- Please contact your local HARDI® dealer.

To contact HARDI® directly:

- Please use the HARDI® Customer Service number: 1-866-770-7063

- Or send your email to CUSTSERV@hardi-us.com

Visit us online at: www.hardi-us.com

HARDI® NORTH AMERICA INC.

1500 West 76th St.
Davenport, Iowa 52806
Phone: (563) 386-1730
Fax: (563) 386-1280

Operator Safety

Symbols

These symbols are used through the book to designate where the reader needs to pay extra attention.



This symbol means DANGER. Be very alert as your safety is involved!



This symbol means WARNING. Be alert as your safety can be involved!



This symbol means ATTENTION. This guides to better, easier and safer operation of your sprayer!



This symbol means NOTE.

Precautions

Note the following recommended precautions and safe operating practices before using the sprayer.

General info



Read and understand this instruction book before using the equipment. It is equally important that other operators of this equipment read and understand this book.



Keep children away from the equipment.



If any portion of this instruction book remains unclear after reading it, contact your HARDI® dealer for further explanation before using the equipment.



Press the keys with the underside of your finger. Avoid using your fingernail.



Local law may demand that the operator is certified to use spray equipment. Adhere to the law.



Tractor driver's seat is the intended working place during operation.

Service



Test with clean water prior to filling with chemicals. Rinse and wash equipment after use and before servicing.



Never service or repair the equipment while it is operating. Always replace all safety devices or shields immediately after servicing.



Turn electrical power off before connecting and disconnecting the display and transducers, servicing or using a battery charger.



If an arc welder is used on the equipment or anything connected to the equipment, disconnect power leads before welding. Remove all flammable or explosive material from the area.



Do not use a high pressure cleaner to clean the electronic components.

2 - Safety Notes

General info

Controller features

The HARDI® Controller 5500 is for use in agricultural and horticultural production. The Controller permits automatic control of application rate.

Main components are:

- Controller HC 5500
- Spray Box III
- Junction box for DF4 regulation
- Junction box on spray boom
- Sensor for spraying pressure (psi)
- Sensor for spray flow (gallons/min)
- Sensor for sprayer's ground speed (mph)
- Sensor for pump speed (rpm)
- Sensor for regulation valve opening (degrees)

The Controller has a 4-line display permitting much information to be shown at the same time.

Display readout includes:

- Volume rate
- Speed
- Liquid rate per minute
- Total area sprayed
- Total volume sprayed

and 99 trip registers. It includes a total register (no. 99), which summarizes data from the 98 trip registers. It is illuminated internally, so readout is possible even for night-time work.

Spray Box III has integrated controls for:

- Spray functions
- Foam marking
- End nozzles control
- Optional functions

The sensors used are chosen for long service life and good signal quality. The speed and flow sensors have a diode built into the housing to aid servicing. As the wheel or rotor turns, the diode will flash, thereby indicating correct function.

The Controller is also compatible for Variable Rate Application (VRA), and it is prepared for communication with Precision Farming tools.

Data dump of registers and configuration to a personal computer is possible.

The system has a non-volatile memory with no battery, which simplifies storage. All parameters in the menus are saved in the Controller's memory, and they are not lost when the power is disconnected.

The Controller has been developed to last many years under agricultural conditions.

Optional sensor includes a tank gauge.

Other options include a 12-volt printer and a foot pedal for the main ON/OFF (spraying ON/OFF).

3 - Description

Glossary and pictorial symbols

Controller	HARDI® Controller 5500 with display and pushbuttons.
Spray Box III	HARDI® Control Box in the tractor with all basic control functions for the sprayer.
Junction box	Box on the sprayer for Controller and Spray Box.
Sensor	Device that transforms variations to a signal; also called a transducer.
[abc]	Text shown on the Controller display.
[X] or [Y]	Variable figures.
PPU	Pulses per unit. For speed and flow calibration, the unit measure is feet and gallon respectively.
EFC	Electric Fast Control unit. Designates a no equal pressure system.
GPS	Global Positioning System to be used for navigation.
VRA	Variable Rate Application (often connected to the GPS system).

Text shown in the shaded rectangular windows are what will be seen on the Controller display when pressing buttons as described in the explanations. An example of display readout is shown to the right.

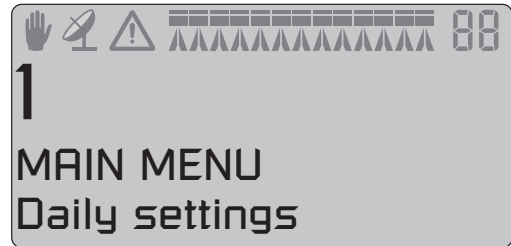

System description

Main components

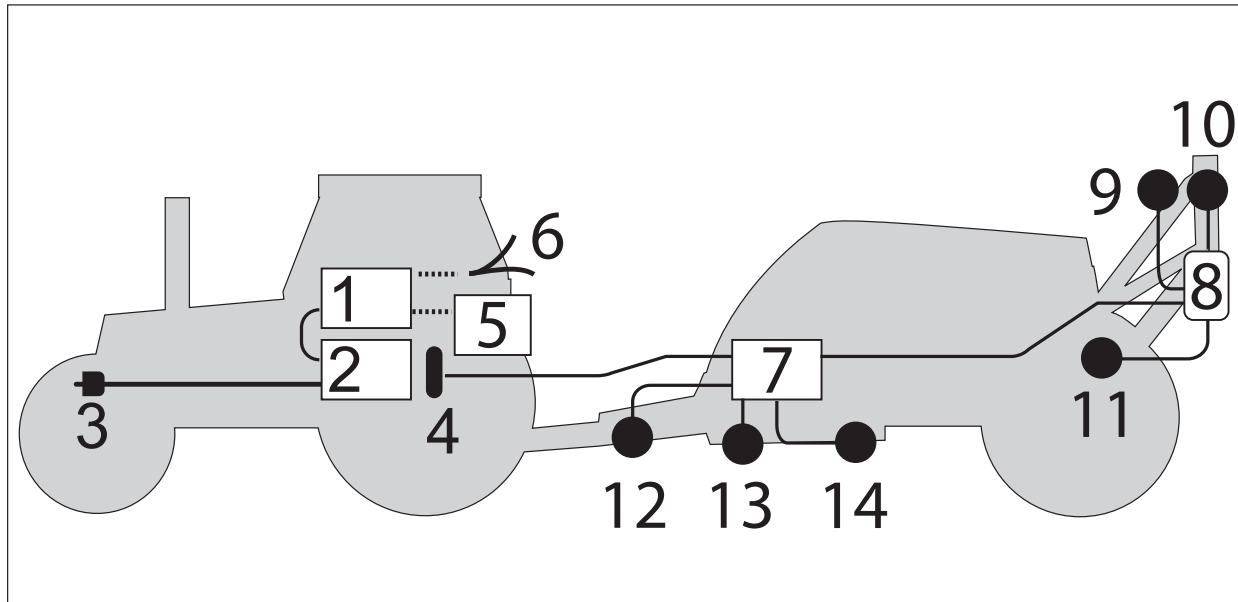

1. Controller HC 5500
2. Spray Box III
3. To 12 volt power supply
4. Multi-wire plug and cable to sprayer
5. Printer *
6. Wire harness for tractor speed, area switch and foot pedal ON/OFF *
7. Junction box for DF4 regulation
8. Junction box on spray boom
9. Sensor for spraying pressure (psi)
10. Sensor for spray flow (gallons/min)
11. Sensor for sprayer's ground speed (mph)
12. Sensor for pump speed (rpm)
13. Sensor for regulation valve opening (degrees)
14. Sensor for tank contents (gallons) *

* Optional equipment.

3 - Description

DynamicFluid4 pressure regulation

Traditional fluid regulation starts when the nozzles are opened.

With DynamicFluid4 (DF4), the regulation is a continuous process, even if the nozzles are closed. Two ceramic (or plastic) discs regulate the pressure and ensures quick reaction and zero leakages. Sprayer speed, PTO speed and number of spray sections activated are parameters used, and the benefit is more precise application rates from the second the sprayer begins spraying.

The DynamicFluid4 use feed forward technology based on 5 sensors, which feed the Spray Box III with data necessary for optimal regulation. It auto-primers the spray boom at start-up and moves the regulation valve towards its final position immediately after the operator makes changes. For example, when section valves are opened or closed, the regulation valve is started at the same time that the section valve motors are started. This prevents overpressure situations, e.g. after running empty and refilling of main tank.

The 5 sensors are also back-up for each other and ensures that the system can continue regulation even if one or more sensor signals fail.

Sensors for DF4:

- Sprayer speed (mph)
- Flow (gpm)
- Pressure (psi)
- Pump speed (rpm)
- Regulation valve opening angle (°)

The DynamicFluid4 pressure regulation features:

- Very fast and accurate regulation when all sensors are working properly, setup in menus are correct and pump, filters and valves are in good condition.
- Quick reacting valve, when sections are turned ON/OFF and at speed changes.
- Optimized for different PTO systems.
- Nozzle surveillance. No setup or tuning required for nozzle change.
- Warning in display if failures occur on boom plumbing, such as severe clogging of line or nozzle filters, or large leakages on hoses and fittings.
- All functions continue working with degraded performance (Limp-home modes), if:
 - Faults occur in fluid system, e.g. pump defects, clogged filters, leaking valves.
 - Sensor failure appears on pressure sensor, flow sensor or pump sensor.
 - There is a wrong setup of sprayer data in the menus.
- Emergency mode, if angle sensor or speed sensor fails.

Keys and Display

General description of controller keys

The controller keys are placed in three groups:

1. Navigation keys (to the right of display)
2. Shortcut keys (below display)
3. Distance key and auto key (bottom right corner)

Navigation keys

They are initially used for set up in the menu system and working screen.

To navigate the menus, press  to start this process. The buttons can be used for the following:

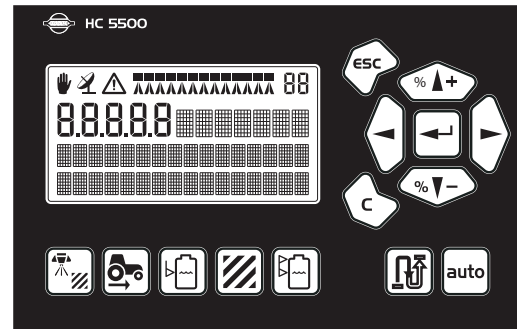

Press  :

- Scroll up,
- Increase an value.

Press  :

- Scroll down,
- Decrease a value.

Press  :

- Move digit selection to the left.

Press  :

- Move digit selection to the right.

Press  :

- Escape a menu (hold button to escape all menus),
- Escape without changing a value.

Press  :

- Clear a value,
- Reset the active register (hold until countdown of 5 seconds is finished).

Press  :

- Enter a menu,
- Confirm (accept) a value.

When at the working screen (not in menu system), the navigation keys can be used for the following:

Press  :

- Increase volume rate in steps or select another preset application rate.

3 - Description

Press  :

- Decrease volume rate in steps or select another preset application rate.

Press  :

- Reset the active register (hold until countdown is finished).

Press  :

- Enter a menu.

Short cut keys

You can either press the keys briefly or a little longer to display different functions.

The shortcut keys can be used for the following:



Short press: Displays volume rate sprayed for the active register.

Long press: Enter menu [1.1 VOLUME RATE] to set the desired volume rate.



Short press: Displays the actual driving speed.

Long press: Enter menu [3.1.1 SPEED] to calibrate a speed sensor.



Short press: Displays the actual tank contents.

Long press: Enter menu [1.2.1 TANK CONTENTS] to change the tank contents value.



Short press: Shows the area covered for the active register.

Long press: Enter menu [1.3.1 SELECT REGISTER] to select a register and view data.



Short press: Shows the spray volume used.

Long press: Enter menu [1.3.1 SELECT REGISTER] to select a register and view data.

Distance key



Short press: Shows remaining spraying distance with actual tank contents.

Long press: Enter menu [4.1.1 DISTANCE] to measure the distance being driven.

Auto key



Press the key to enable automatic spray function.

General description of display

There are four lines with symbols, numbers and text when looking at the working screen. The appearances of these items at the screen depend on the controller settings and spray functions.

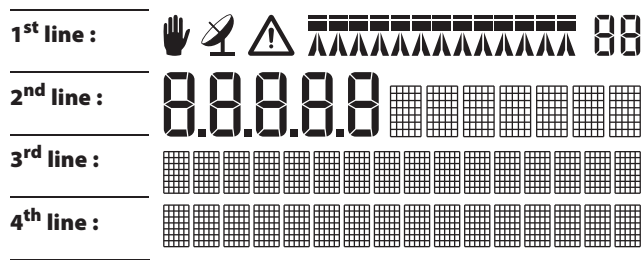

1st line



Manual adjustment of the spray pressure has been activated on the Spray Box.



Variable rate application (VRA) is enabled from an external source, e.g. a GPS system.



Warning.



Spray section = ON. Main ON/OFF switch = ON. Spraying is in progress.



Spray section = ON. Main ON/OFF switch = OFF. No spraying.



Spray section = OFF. Main ON/OFF switch = ON. No spraying in the section, which is turned OFF.
The symbol is flashing when the main ON/OFF switch is ON.



Register number.

2nd line

Current value as selected from the five shortcut buttons below the screen. Default value is spray output (gallons/acre).

3rd line

Spray parameter and current value as selected in the setup menu. Default value is spray pressure (psi).

4th line

Spray parameter and current value as selected in the setup menu. Default value is time of the day (hours:minutes).

3 - Description

General description of switches for Spray Box III

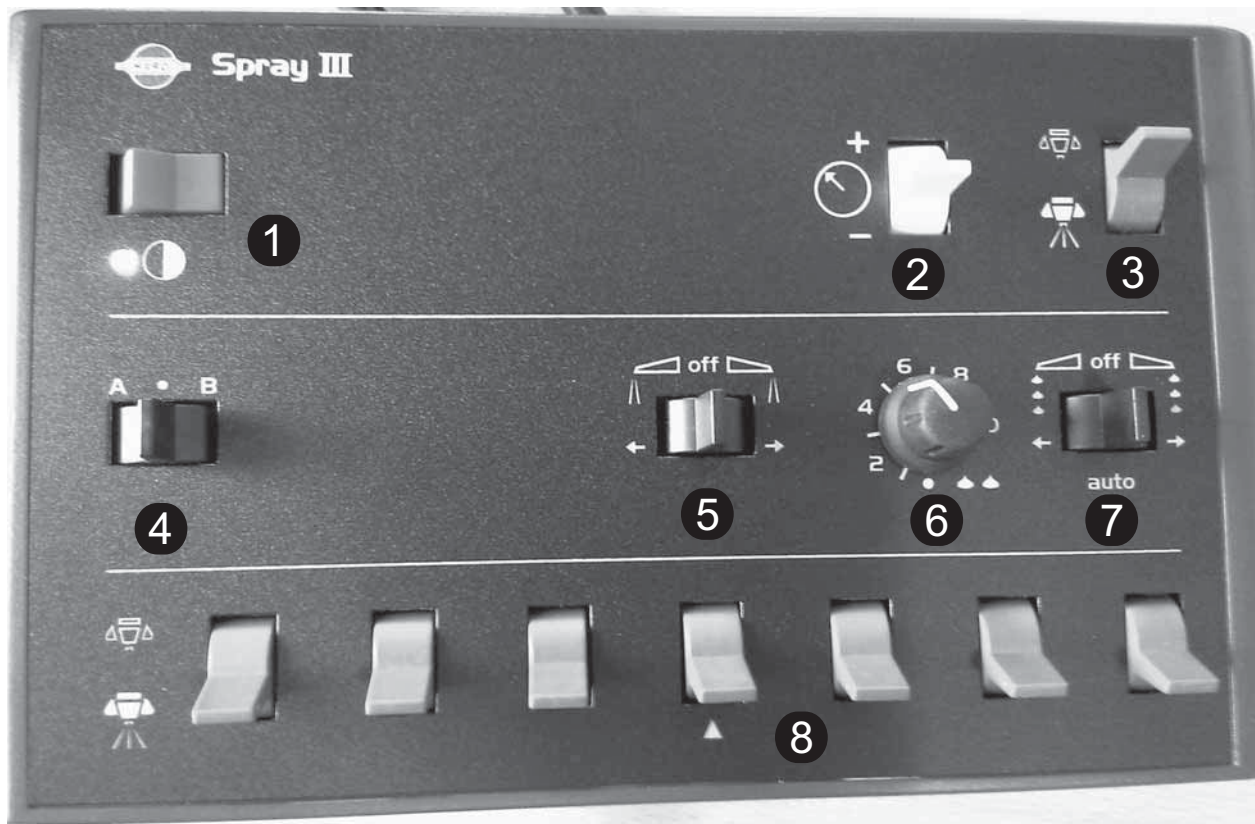

1. Power ON/OFF - This switch controls both the Spray Box and the Controller. When turned on, the lamp below the switch will flash red three times, and then display a constant green light. If a constant red light is shown, there is a malfunction in the Spray Box, and you should contact HARDI® for technical assistance.
2. Pressure regulation - Used to adjust the spray pressure up or down manually. When this switch is activated, the hand symbol appears in the top left corner of the controller display. To return to automatic pressure control, press the AUTO key on the controller.
3. Main ON/OFF - Turns Spraying ON or OFF.
4. Options control - Select option A or B or none, depending on how the optional equipment (if any) is connected.
5. End nozzle control - Select left or right side for spraying boundaries of the field, if needed.
6. Foam marking - Select the frequency of foam markings on the ground. 1 = few markings, 10 = many markings.
7. Foam marking - Select left or right side for foam markings.
8. Boom section valves - Sets Spraying ON/OFF for individual spray boom sections.

General keystrokes, example

The following is a general description in keystrokes and display readout on the controller. The following example of changing the tank contents value is used to illustrate this. Try it! The same method is used in all the menus.



ATTENTION! The top line of symbols will stay shaded, unless the symbols are relevant. When a menu is open, the flashing number or value is the one that can be altered.

Press to enter the menu system [1 MAIN MENU].

The 2nd line shows the menu number.

The 3rd line shows the present menu.

The 4th line shows a choice.



NOTE! The menu number [1] is flashing.



Press to enter menu [1.1 DAILY SETTINGS].

Press to scroll to menu [1.2 Tank].



NOTE! The last digit of the menu number [1.2] is flashing.

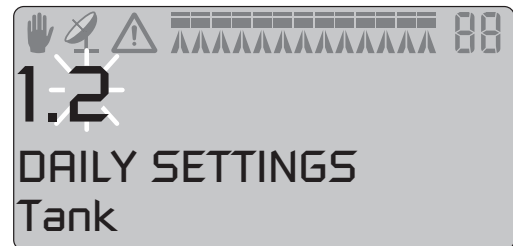

Press to enter menu [1.2.1 Tank contents].



NOTE! The value that can be changed is flashing.

Press or to move the select the digit.

Press or to set the desired value.

Press to confirm.

Press and hold, to exit the menu system.

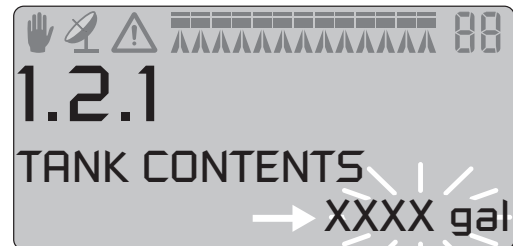

3 - Description

Menu tree

The first steps for choosing a menu are shown below. Menus and submenus are described in the relevant sections in this instruction book.

While at the start screen / working screen, press  to proceed into the menu.

Press  and hold to exit the menu system.

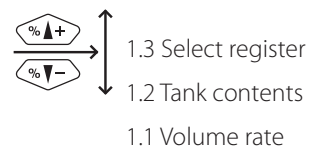
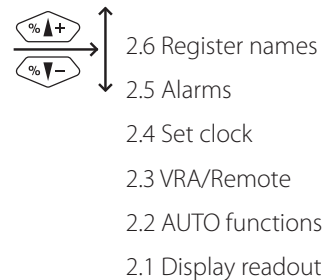
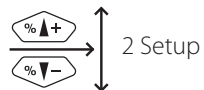
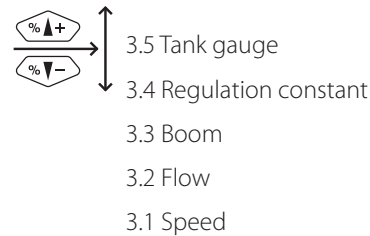
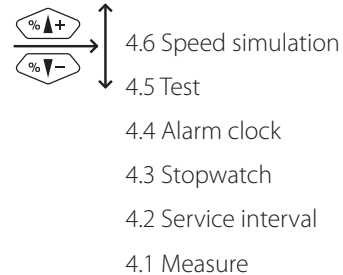
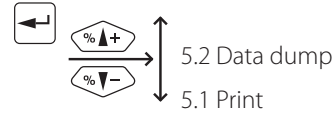

Tractor installation

Control units

Find a suitable place in the tractor's cabin to secure the control units against movement. Best recommended placement is to the right of the driver seat.

The supplied bracket will fit most tractors. Threaded mounting holes may be hidden behind front corner cover.

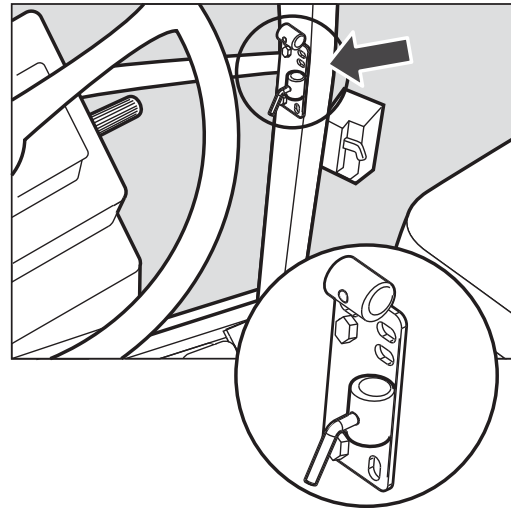

Installation of control unit brackets

The supplied tractor pillar bracket (A) has a hole spacing of 3.9 in. (100mm) and 4.7 in. (120mm). Check tractor instructions manual for information regarding attachment points.

Three tubes (B) are supplied. One, two or all three may be used. They can be bent and shortened. A spacer (C) is also supplied to allow further attachment possibilities. Find the best solution for your tractor or vehicle.

Tube (B) plate is staggered so all boxes will line up if correctly orientated.

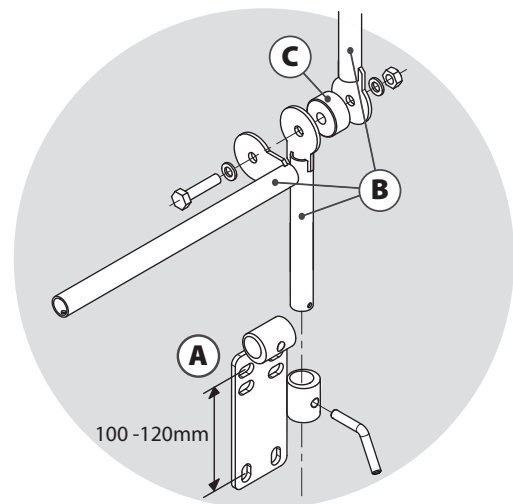

The recommended setup is to place the spacer (C) between the two tubes (B) used for the controllers. Place the third tube (B) as shown in the picture, so it can be mounted in the bracket (A).



ATTENTION! An extension cable is available as an option if the HC 5500 control unit is to be placed further away from the EFC control unit. Contact HARDI® for further details.



4 - System setup

Power supply

The power requirement is 12-15 Volt DC. Always note the polarity!

Brown wire is positive (+)

Blue wire is negative (-).

Power supply must come directly from the battery. For proper function of the electric equipment, the wires must have the following recommended gauge ratings and correct fuses to ensure a sufficient power supply. The supplied power connectors follow the standard of most newer tractors. If using a tractor with another power connector, it is necessary to disassemble the connector and fit it to the existing tractor connector.

Use the HARDI® Electric distribution box (item no. 817925) to ensure a good connection.

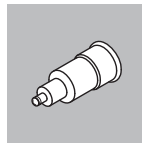
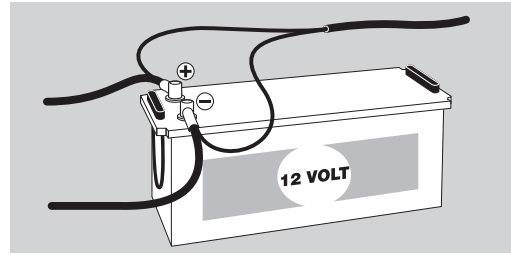

LIGHTER CONNECTOR

Spray control unit requires:

Wire 12 awg, Fuse 10 Amp.

Hydraulic control unit requires:

Wire 10 awg, Fuse 16 Amp.



WARNING! Do not connect to the starter motor or generator/alternator. The HARDI® warranty is void if this is done.



ATTENTION! See "Initial system start-up" on page 24 for more about connecting the controller.

Printer

If the 12 volt printer is fitted, the supplied tube can be utilized to fit the printer on the Controller/Terminal brackets.



ATTENTION! The Controller/Terminal should be protected from moisture and should be removed when not in use if the tractor does not have a cabin.

4 - System setup

Speed sensor for the sprayer

The speed sensor is located at the inside of the sprayer's right wheel. It measures the sprayer's ground speed.

It is an inductive type that requires a metallic protrusion to pass by it to trigger a signal.

To trigger, a speed ring is used. It should be adjusted so that the sensor is pointing to the middle of the gaps (vertically) in the speed ring.

Assure that the speed ring is correctly fitted to the wheel so that the arrow (A) follows the forward rotation of the wheel.

Recommended distance (B) between protrusion and sensor is 1/8" to 1/4" (3 to 6 mm). Check throughout entire circumference when spinning the wheel. The distance tolerance should be +/- 0.5 mm.

Correct adjustment is indicated by a constant flashing from the sensor when the wheel is rotating.

The pictures show different examples of the sensor with brackets - these may differ a little depending on the sprayer model.

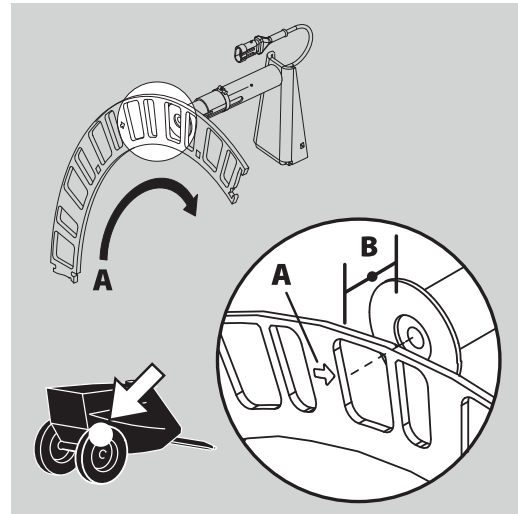
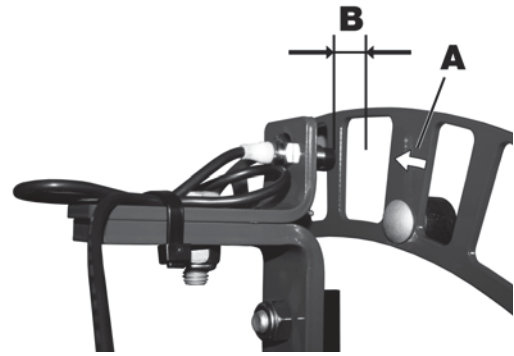

Speed sensor for the tractor

It is possible to connect a speed sensor from the tractor's gearbox or radar/GPS to the controller. A speed/switch wire harness (A) and extension cable are needed to connect the speed sensor to the Controller/Terminal.

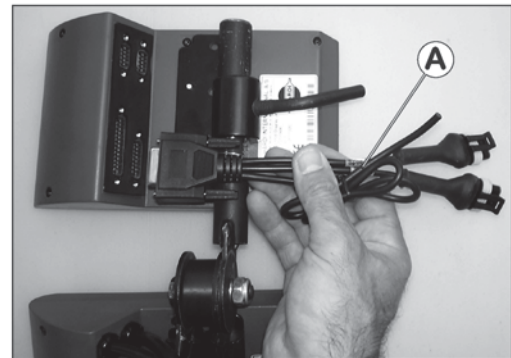

4 - System setup

Foot pedal remote

A foot pedal remote switch can be fitted to turn the spraying ON/OFF. Note the following if the foot pedal remote is to be fitted.

- The remote has to be activated from the extended controller menu at installation. The HARDI® Service center does this.
- The speed/switch wire harness (A) is connected to the Controller. Connect the plug from the foot pedal ON/OFF to the correct connector on the wire harness (A).



ATTENTION! The main ON/OFF valve switch on Spray Box III (green button in the top right corner) overrides all remote switches. This button must be set to ON (pressed down) for the optional foot pedal remote to function.

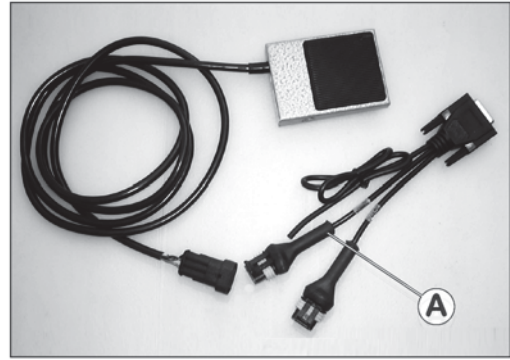

Initial system start-up

When connecting the 39-pin plug from the sprayer, please note the one-way brackets inside the connector and connector plug. There are two different brackets designating connector plug for liquid (1) and hydraulics (2) respectively.



ATTENTION! The Controller/Terminal should be protected from moisture and should be removed when not in use if the tractor does not have a cabin.

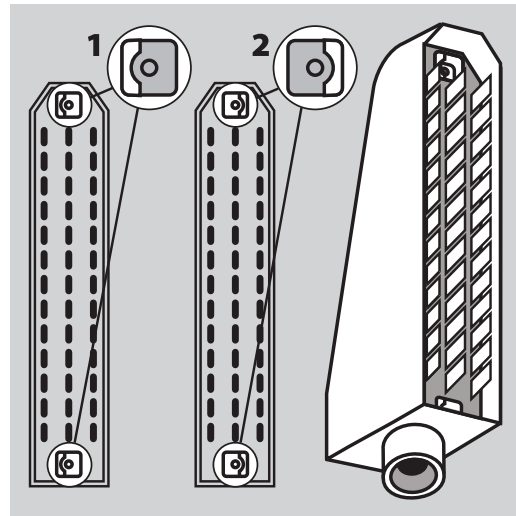

Hook the top of connector plug first, then make sure lock tab (A) clicks into place to secure the plug.

When disconnecting the plug, lock tab (A) must be pushed back before the plug can be pulled out.

After connecting the plugs, the power is turned on at the red switch on the Spray Box connected to the Controller.

The lamp below the switch will flash red, and then it turns green.

Press to continue.



ATTENTION! At the very first start-up, the time and date must be set in order to make the registers work properly (if not preset from the factory). See menu [2.4 Set Clock].

Screen contrast adjustment

The screen contrast can be adjusted by pressing and then use the or to find the correct setting. This can only be done when "working screen" is active, i.e. not when any menus are active.

Note that this function will only be available on hardware version 2.0 and higher.

Daily settings

System start-up

When the HC 5500 is turned on, a boot sequence is started while the controller is initiating itself.

If the Controller is put into operation for the very first time, it will prompt for date and time. Please see menu [2.4 Set Clock] for details on setting of clock.

During start-up, the display lists information in the following order:

1. A screen showing

- the controller model is an HC 5500 and the current software version in the 3rd line of the display.
- a serial number for the controller in the 4th line of the display.

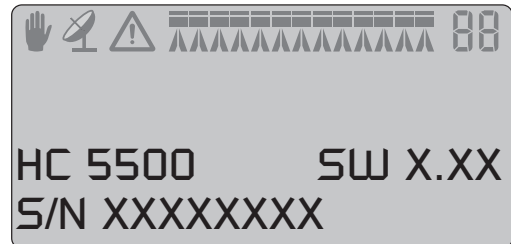

2. A screen showing

- boom length (in feet & inches) in the 3rd line of the display.
- number of spray sections programmed into the controller in the 4th line of the display.

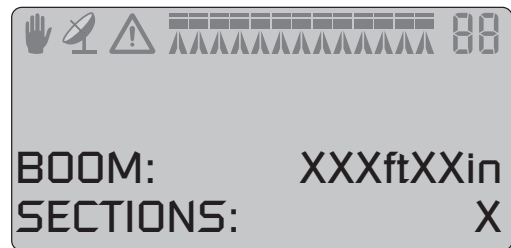

ATTENTION! This data should reflect the actual sprayer. If not, please contact your local HARDI® dealer to correct this.

Menu 1.1 Volume rate



How to change the volume rate

The volume rate (gallons/acre) can be changed by doing one of the following four actions.

1. Set the desired rate in the Controller menu [1.1 VOLUME RATE].

This menu can be accessed by pressing  for a few seconds.



Move with  or  for selecting the value digit to be changed.

Use  or  to change the value.

Press  to save the setting.

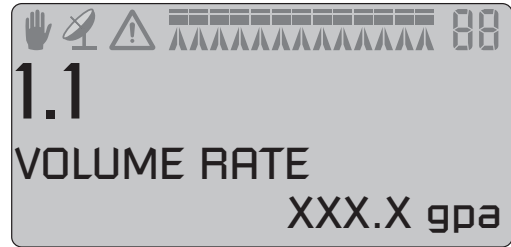
Press  and hold to exit the menu system.



2. On the working screen: Press  or  to spray a percentage over or under the preset volume rate, in steps of 10 %. The 3rd line in the display indicates the current setting when this is activated.

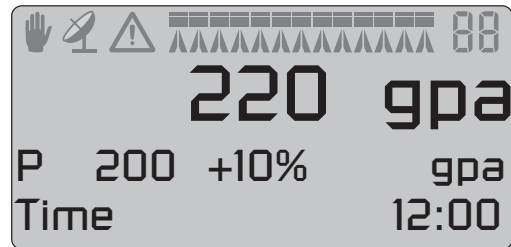

The limits are +/- 99 % of the preset volume rate.

In this example, the preset volume rate is 200 gpa. While spraying, the operator has increased it by 10 %.



3. Manually raise or lower the pressure via the yellow switch on the Spray Box III.



4. When working (at working screen): Press  or  to change to 1 of 3 preset volume rates.
If the volume rate is set up with 3 programmable rates, there are 3 options to enter a volume rate.
Menu [1.1.1: RATE 1], default
Menu [1.1.2: RATE 2]
Menu [1.1.3: RATE 3]

 ATTENTION! It can be useful to change the volume rate when spraying under these conditions:

- when spraying the field boundaries or headlands.
- when spraying areas with large quantity of weeds.
- when shifting gear (useful for some tractor models).
- when nearing the end of spraying a field and the main tank must be empty when finished.

 ATTENTION! To return to the normal working screen, press .

5 - Menu 1, Daily Settings

How to read the preset volume rate

Shortcut key  on the controller.

Press  and hold, until menu [1.1 VOLUME RATE] is shown.

How to use manual dosage

To dose your spraying manually, use the pressure switch on the Spray Box (yellow switch). The manual mode is indicated by the  symbol at the top of the display.

To go from manual to preset volume rate, press .

Menu 1.2 Tank contents

How to change the tank contents



Shortcut key 

Press  and hold until menu [1.2. TANK CONTENTS] is shown.

The maximum size of the tank is displayed.

Press  again and the tank contents maximum value is shown.

Press  or  to move to the digit to be changed.

Press  or  to set the desired value.

Press  to confirm.

Press  and hold to exit the menu system.



5 - Menu 1, Daily Settings

Menu 1.3 Select register

How to select a register and its data

Registers 1 to 98 can be used for individual spray areas.

They are identified with a number and it is also possible to name them. The active register is always visible in the upper right corner of the display (see arrow).

The data is saved when the system is switched off.

Register 99 is a tally of registers 1 to 98.



To read the totals of all registers

Shortcut key

Press and hold until menu [1.3.1 SELECT REGISTER] is shown.

Press or to go to register 99. The number is shown in the top right corner, and the name on the 4th line (if present).

Press to enter the register.

Press to scroll through the data.

Press and hold to exit the menu system.

To read the data in an active register

Shortcut key

Press and hold until menu [1.3.1 Register XX] is shown.

Press to enter register in menu 1.3.1.1.

Press to scroll through the data from the selected register in menus 1.3.1.1 - 1.3.1.5.

Menu number	1.3.1.1	1.3.1.2	1.3.1.3	1.3.1.4	1.3.1.5
Display text in 3rd line	Start date and time	Spray volume used (gal)	Average driving speed (mph)	Distance sprayed (miles)	Spray rate (acres/hour)
Display text in 4th line	Stop date and time	Area sprayed (acres)	Max. driving speed (mph)	Time sprayed (hh:mm)*	Average volume rate (gpa)

* In register number 99, the total time sprayed is shown only in hours.

Press and hold to exit the menu system.

To reset a register

Press and hold until the countdown of 5 seconds has ended.

Reset of a register can be stopped if the key is released before the countdown has ended.

To change a register

Shortcut key

Press and hold until menu [1.3.1 Register XX] is shown.

Press or to change the register.

The number is shown on the 1st line and if present, the name on the 4th line.

Press . If necessary, the register can be reset.

Press until the countdown has ended.

Press and hold to exit the menu system.

ATTENTION! The active register number is always visible in the right upper corner of the display.

ATTENTION! Naming of registers - see menu 2.6.

Menu 2.1 Display Readout

General info

When reading the following menu explanations, it is assumed that you have mastered the general keystrokes and you can “find your way” to the specific menu. If this is not so, please read the section “Keys and Display” on page 15 again.

Example of readout

It is possible to freely choose which function is to be shown on the 3rd or 4th line of the working screen.

Choose the submenus of menu [2.1 Display readout].

Choose a submenu e.g. the menu [2.1.5 Work rate].

Press  to confirm.

Use  or  to choose which line is to show data. The display will change as shown.

Press  to confirm.

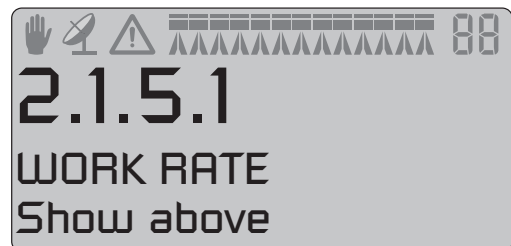

ATTENTION! As some readouts require extra sensors, the relevant sensor has to be connected to get a readout.

Menu 2.1.1 Program : Actual

Programmed and actual application rate (gallons per acre).

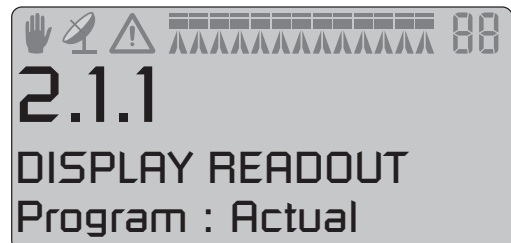

Menu 2.1.2 Flow rate

Flow rate out to the spray boom (gallons per minute).

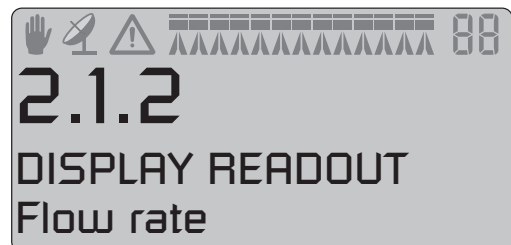

6 - Menu 2, Setup

Menu 2.1.3 Optional sensor

There are up to 3 sensor options.

Submenus:

[2.1.3.1 Pressure]. Spray pressure (psi).

[2.1.3.2 Fan]. TWIN fan speed (rpm).

[2.1.3.3 RPM sensor]. Pump speed (rpm).

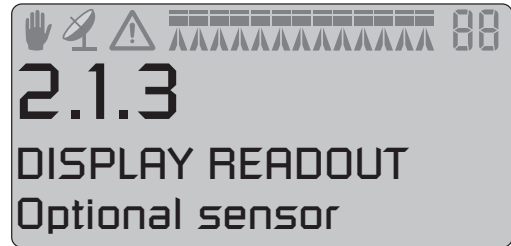

Menu 2.1.4 Time

Actual time (hours and minutes).



Menu 2.1.5 Work rate

Work rate (acres per hour).

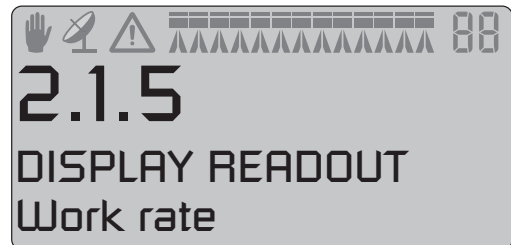

Menu 2.1.6 Volume rate

Actual rate (gallons per acre).

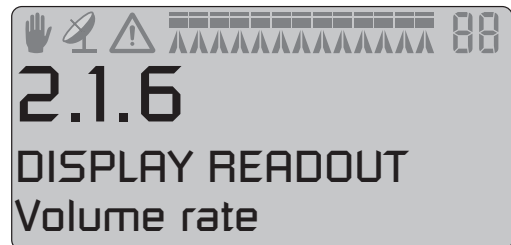

Menu 2.1.7 Tank contents

Main tank contents (gallons).



Menu 2.1.8 Speed

Driving speed (miles per hour).

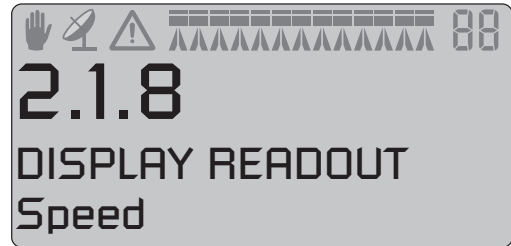

Menu 2.1.9 Volume : Area

2 readouts on the same line for volume (gallons) and area (acres).



Menu 2.1.10 Active boom size

Active boom size including end nozzles (feet & inches).

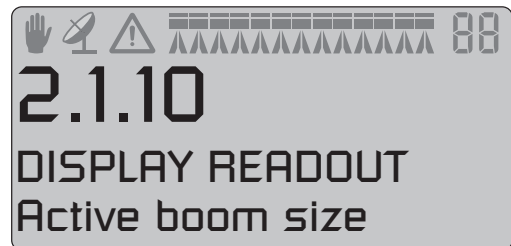

6 - Menu 2, Setup

Menu 2.2 Auto Functions

Menu 2.2.1 Auto ON/OFF

The Controller can be set to open the main ON/OFF spray function above a certain speed and close it below the same speed. This allows the user to concentrate on driving. If the speed is set at zero, the function is deactivated. Suggested speed setting is spraying speed less 20%.

When the Auto ON/OFF is active, and the main switch and boom section switches are on, the boom status symbol on the 1st line will flash, when the speed is below the trigger value.



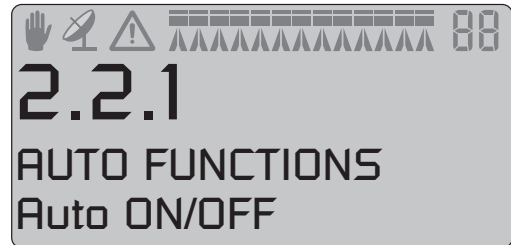

WARNING! Remember to set the main ON/OFF switch to OFF, before leaving the field, otherwise the main ON/OFF will open during transport!



Menu 2.2.2 Foam marker (optional)

The Controller can be set to operate the HARDI® Foam marker automatically through the main ON/OFF valve. When the main ON/OFF is ON, it will automatically start the foam marker.

Furthermore, the foam marker can be set for back and forth spraying or race track spraying (round and round).

Enter the menu 2.2.2. Select your setting by using the arrow key  to select one of the following settings. Press  to save the setting.



NOTE! Foam marker status is shown flashing on the 4th line on the screen in this menu.

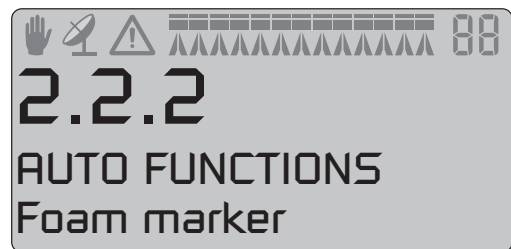

Disable

The foam marker will only follow the setting of the main ON/OFF on the Spray Box.

Same side

The Controller will automatically activate the same side for race track spraying.



Change side

The Controller will automatically change side for back and forth spraying.

Menu 2.3 VRA/Remote

VRA / Remote Control/ AutoSectionControl

If the volume rate setting is to come from an external source (e.g. a site specific application map or a remote sensor like a GPS-based AutoSectionControl system), this menu has to be enabled.

Enter the menu 2.3. Select your setting by using the arrow key  to select one of the following settings. Press  to save the setting.

Disable

Disable external source control.

Enable

Enable external source control.

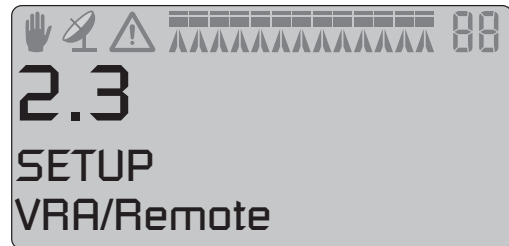

The  symbol on the 1st line will be visible when enabled.



ATTENTION! Manual pressure regulation and adjusting the percentage over/under application rates are still applicable.

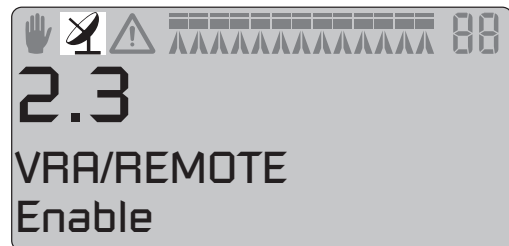

The external source is connected to the COM 1 or COM 2 via a 9-pin sub-D connector.

The baud rate for the equipment should be set at one of the following values before transmitting data:

- 19200 baud
- 9600 baud (default for HC 5500)
- 4800 baud
- 2400 baud
- 1200 baud



ATTENTION! The COM port may have to be set up in the extended menu. Contact your HARDI® Service center.

6 - Menu 2, Setup

Menu 2.4 Set Clock

How to set clock

If the controller prompts for date and time, the clock must be set to enable a register.

This must be done before the controller is put into operation for the first time, otherwise no start and stop time will be recorded in the registers.



ATTENTION! If no prompt when turning on the controller, the dealer may already have completed this setting.

Enter menu 2.4. Choose between a 24 hour or a 12 hour clock with .

Press  to save the setting.

Set minutes, hours, year, month, and day with  and .

Press  to confirm.

Press  and hold to exit the menus.

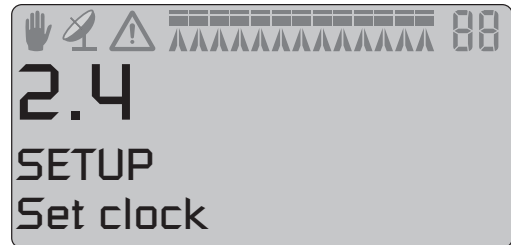

Menu 2.5 Alarms

How to set up alarms

5 different alarms can be set up in the following menus 2.5.1 - 2.1.5.

When outside the alarm parameters, the relevant alarm will flash in the display.



The alarm beep can also be adjusted in audio level in menu [2.5.6 Audio level].

A warning in the display for individual spray sections OFF can be selected in menu [2.5.7 Sections off].

Menu 2.5.1 Volume rate

Deviation to programmed volume rate.

The alarm will show in the display for more than 20 seconds in case of higher or lower application rate outside the deviation limit.

Adjust the value with  and .

Press  to save.

Press  and hold to exit the menu system.

Suggested setting is 10%.

For no alarm, select 00%.

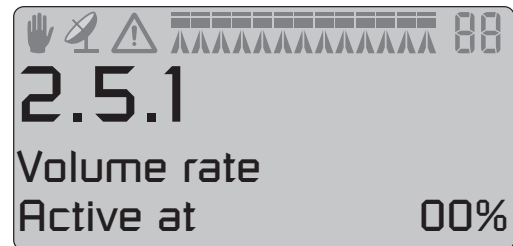

Menu 2.5.2 Tank contents

Minimum tank contents in gallons.

Adjust the limit value with  and .

Press  to save.

Press  and hold to exit the menu system.

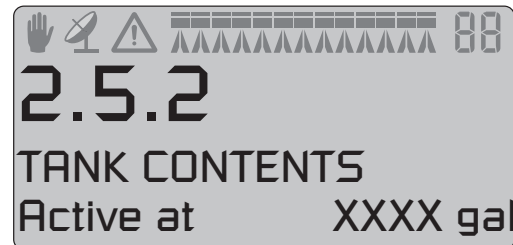

Menu 2.5.3 Spray pressure

Spray pressure limits in psi.

Adjust the limit value with  and .

Press  to save.

Press  and hold to exit the menu system.



6 - Menu 2, Setup

Menu 2.5.4 Fan speed

TWIN blower speed limits in rpm.

Adjust the limit value with  and .

Press  to save.

Press  and hold to exit the menu system.

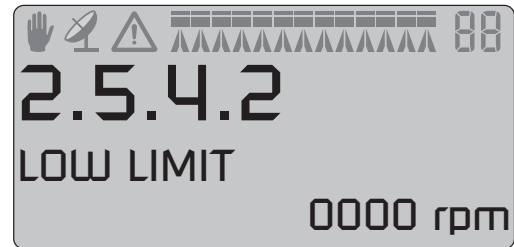
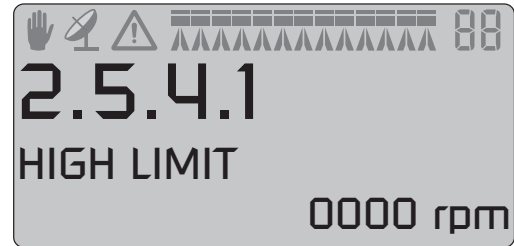

Menu 2.5.5 Speed

Driving speed limits in mph.

Adjust the limit value with  and .

Press  to save.

Press  and hold to exit the menu system.



Menu 2.5.6 Audio level

It is possible to change the sound level for alarms.

Set the sound level by changing the sound step with  and .

0 = no sound, 5 = max. volume.

Press  to save.

Press  and hold to exit the menu system.



Menu 2.5.7 Sections off

Enable or disable warning in the display, when the main ON/OFF is ON (green switch in the top right corner of the Spray Box), and one or more spray sections are OFF.

Enable

Warning will appear in the display.

Disable

No warning.

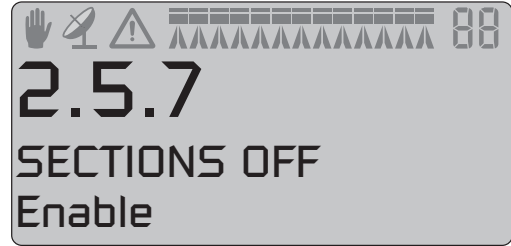

Select Enable or Disable with .

Press  to save.



Press  and hold to exit the menu system.

6 - Menu 2, Setup

Menu 2.6 Register Names

How to name the registers

If desired, the registers can be given names. Once set up, a name can be copied and edited.

Press  or  to toggle between [Yes] or [No].

Press  if the name can not be copied or edited.

A "?" will flash on the 3rd line.

Menu 2.6.XX Copy name?

Register number

Menu number

3rd line flashing

Available letters



 Moves "?" one step to right.

 Moves "?" one step to left.

 or  Changes character set.

 Activates letter in 4th line exchanging with "?" in 3rd line.

 Leaves the menu.

 No effect.



Assuming  is pressed, "A" will flash in both the 3rd and 4th line.

 "B" will flash in both the 3rd and 4th line.



 "P" will flash in both the 3rd and 4th line.

 or  Changes character set.

 Selects letter and returns to 3rd line.

The second letter can now be selected.

Press  to select [Yes].

Press  or  to scroll through the defined names. The register number on the 1st line will change accordingly.

Press  to select.

The name can be copied and edited.

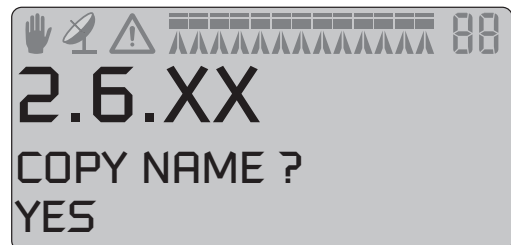

Menu 3.1 Speed calibration

Menu 3.1.1 Sprayer

The calibration process is the same for each sensor type. In the following example, a “speed sensor on sprayer” is used.

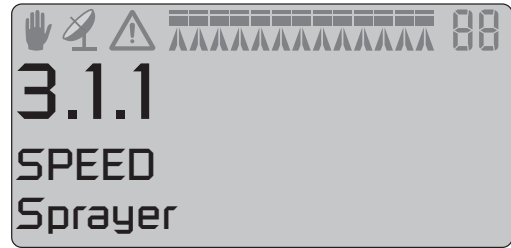

Shortcut button  when on the working screen.

1. Press  a few seconds, until menu [3.1.1 Sprayer] is shown.

It is possible to connect the speed sensor at different locations. See chapter 4 - System setup for more about this. They are calibrated in the following menus:



[3.1.1 Sprayer] Speed sensor on sprayer

[3.1.2 Tractor] Speed sensor on tractor

[3.1.3 Radar] Radar speed sensor

2. Select with the navigation keys.
3. Press  to confirm. The last confirmed sensor is the active speed sensor.

Shortcut button  when at the working screen.

4. Press  until menu [3.1.X “Speed ...”] is shown.
5. Choose speed sensor (Sprayer, Tractor or Radar)
6. Press  to confirm.
7. Press  to read PPU value. PPU = pulses per unit.



ATTENTION! Be aware that even if tractor speed sensor and radar speed sensor uses the same connector, the PPU value may be very different.



ATTENTION! The speed sensor can be calibrated theoretically or practically. The practical method is recommended.

7 - Menu 3, Calibration

Menu 3.1.1.1 Constant

The theoretical speed constant, pulses per unit (PPU), is calculated from this formula:

$$\text{PPU} = \frac{A}{B}$$

A = number of metal protrusions in the speed ring inside the wheel, which the speed sensor records during one full turn of the wheel. The sensor flashes once for every metal protrusion on the speed ring, when the wheel is turning.

B = the outer circumference of the sprayer's wheels in feet.

Example:

Wheel circumference = 19 feet, number of sensor flashes = 36, resulting in a PPU value of 1.895.



NOTE! For more about the speed ring, see "Speed sensor for the tractor" on page 23.

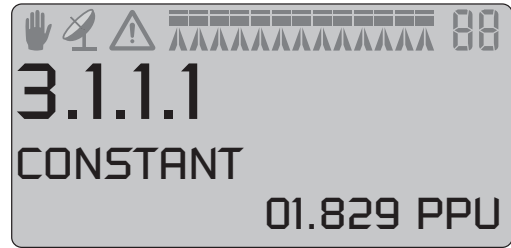

Menu 3.1.1.2. Practical

Practical calibration of speed is done by driving a measured distance and correcting the display, so that the actual and the calculated distances are the same. Calibration should take place in the field with a half full tank and normal working pressure in the tires in order to obtain the real "working radius" of both wheels.

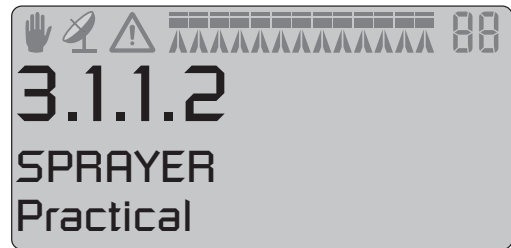

Calibration method

1. Measure a distance not less than 250 ft.
2. Park the tractor at the start of the measured distance.
3. Press . When zero distance [0 ft] shows, drive the distance.
4. Press when finished driving.
5. Correct the distance shown on the display with the or to read the actual distance.
6. Press to confirm. The PPU value is now adjusted.

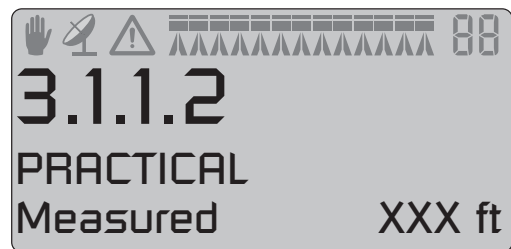

ATTENTION! The PPU value should be readjusted if you:

- change the tire pressure
- change to a different size of tires on the sprayer.



NOTE! Use the table in the back of this book to record your values for later use.

Menu 3.2 Flow calibration

Which method to use

The flow sensor can be calibrated theoretically or with two practical methods. The practical methods are preferred. Calibration is done with clean water. The Flow Tank method is time consuming, but is more accurate than the Flow Nozzle method.

When changing to nozzles with more than a 100% increase or decrease in output, it is recommended to recalibrate the flow sensor.

Calibration is recommended to be done at least once during the spraying season.

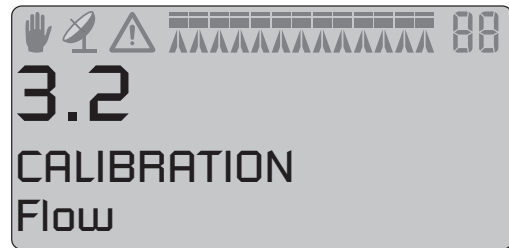

Menu 3.2.1 Flow constant

Use the navigation keys to change the flow constant theoretically.

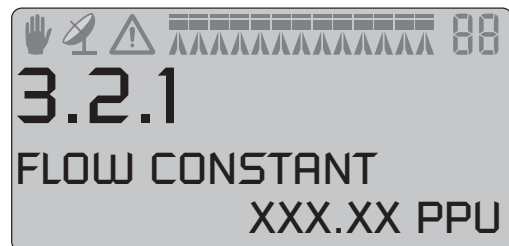

Approximate PPU values for different flow housings are as follows in the table. Different flow housings are designated by grooves (A).

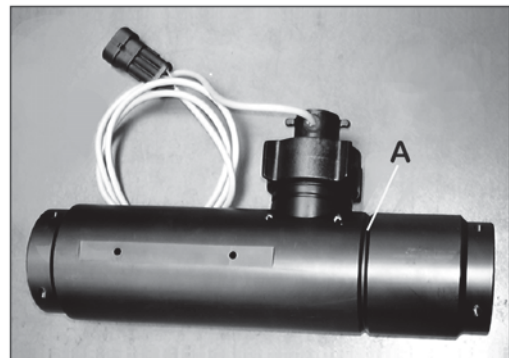

Housing	Housing identification (A)	Flow range g/min.	Orifice mm	PPU value
S/67	One outside groove	2 - 30	13.5	485.00
S/67	No groove	4 - 70	20.0	225.00
S/67	Two outside grooves	20 - 160	36.0	60.00

Pressure drop over the 13.5 mm orifice is 14.5 psi at 39.6 g/min.

i NOTE! PPU indicates the number of pulses, which theoretically come from the flow sensor while 1 gallon of liquid passes through.

i NOTE! Use the table in the back of this book to record your values for later use.

7 - Menu 3, Calibration

Menu 3.2.2 Nozzle method

During practical flow calibration, the individual nozzle output on the display is compared to the actual individual nozzle output. The output displayed is corrected to read the actual output.



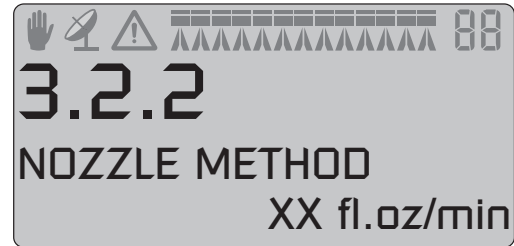

ATTENTION! See menu [3.3 Boom] if no boom data has yet been entered.

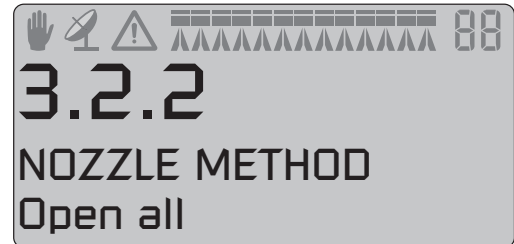

If a section has not been opened or a end nozzle is not closed, the warnings below (next two pictures) will show up in the lowest line on display. If the boom symbol on the 1st line flashes, set menu [2.2.1 AUTO ON/OFF] to [0.0 mph].



Method

1. Open all boom sections. Switch the main ON/OFF to ON. Close end nozzles (if fitted).
2. Go to menu [3.2.2 Nozzle method]. The display will then show the individual nozzle output per minute.
3. Using a HARDI® calibration jug, check the actual nozzle output per minute. It is recommended that an average of several nozzles is taken.
4. Press .
5. Correct the output shown on the display with the navigation keys to read the average output measured with the calibration jug.
6. Press  to confirm.

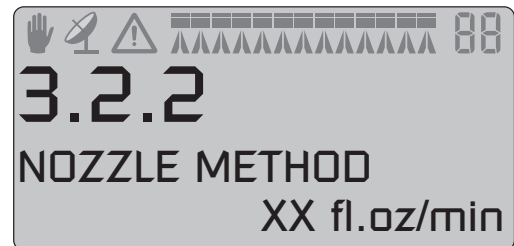
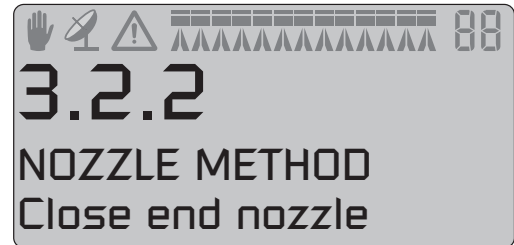



Menu 3.2.3 Tank method

During practical flow calibration the tank is partly emptied through the nozzles. While emptying, the display calculates the quantity emptied on the basis of the actual calibration value (PPU). The quantity displayed is compared with the quantity actually dosed.

This can be according to the tank contents level indicator or by weight difference before and after. The quantity displayed is corrected to read the quantity actually dosed.



Method

1. Place the tank on level ground and fill it up with water until the level reaches a unique mark on the tank contents level indicator, e.g. 500 gallons.
2. Open all boom sections.
3. Go to menu [3.2.3 Tank method] and switch the main ON/OFF to ON.
4. Engage the PTO. The display unit will then begin to count the volume being emptied through the nozzles.
5. When, for example, 300 gallons have been emptied out, as shown by the tank contents level indicator, disengage the PTO and switch the main ON/OFF to OFF.
6. Press .
7. Correct the volume shown on the display with the navigation keys to read the volume shown on the tank contents level indicator.
8. Press  to save.

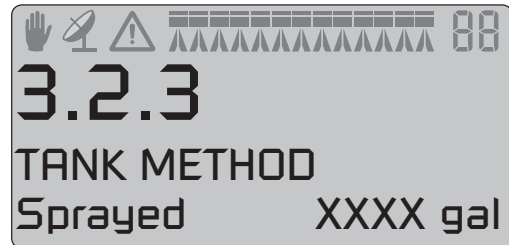

7 - Menu 3, Calibration

Menu 3.3 Boom

Menu 3.3.1 Width

Use the navigation keys to enter boom width.

Press  to confirm.



Menu 3.3.2 Number of sections

Use the navigation keys to set number of boom sections.

Press  to confirm.

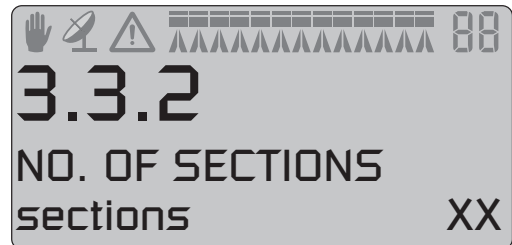

Menu 3.3.3 Nozzles/section

Use navigation keys to set correct number of nozzles per section.

Press  to continue to next boom section.

Press  after the last section.

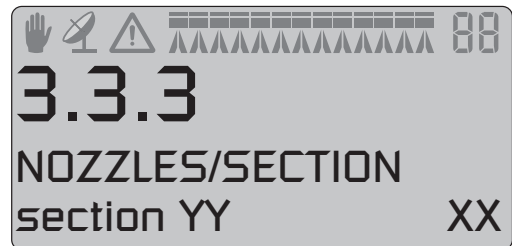

Menu 3.3.4 End nozzles

If end nozzles are fitted, set the value to the equivalent coverage by the boom nozzles.

Example

End nozzle coverage is 5 feet. This is equal to 3 boom nozzles.

The value is then adjusted to 03.



ATTENTION! It is important that the volume applied from the end nozzle matches the volume applied under the boom. This is a comparison of volume per minute per length (Gallon/min/foot).

When the end nozzle is active, the area covered and volume sprayed is calculated and registered. If "Active boom size" is displayed, it will show an increase, when the end nozzle is activated.

Menu 3.4 Regulation constant

General info

The sensitivity of the pressure regulation valve can be adjusted. Values are to be set for obtaining precise regulation, even if sensors fail.

The regulation valve is controlled by up to five main sensors:

Speed sensor

This sensor reads the sprayer's forward speed, which is used for calculating the volume rate at all spraying speeds.

Flow sensor

This sensor reads the flow at the operating unit, which is used for calculating the pressure at all flow rates.

Pressure sensor

This sensor reads the pressure at the operating unit, which is used for calculating the flow at the pressure regulation valve.

Pump sensor

This sensor reads the pump speed (rpm), which is used to calculate the flow from the pump at all pump speeds.

Regulation valve sensor

This sensor reads the opening angle for the rotary valve inside.

When the opening angle is known, the flow can be calculated, when the pressure is also known. The result is that when forward speed, pump speed etc. are known, the regulation valve can then predict the setting (Feed Forward), before opening the main ON/OFF. Thereby the volume rate is correct, even if the forward speed has changed significantly, since the main ON/OFF was closed (no fluctuation).

Menu 3.4.1 Flow sensor restriction

The menu defines the resistance in the plumbing and circuits of the specific sprayer setup. As the resistance varies with the choice of flow housing, this must be set up prior to spraying.

- Select a value below and enter it in this menu. Use the arrow keys to select and change the digits in the display and press Enter to save.

Flow housing	Flow (g/min)
HARDI 13.5 mm	26
HARDI 20 mm	41
HARDI 36 mm	48

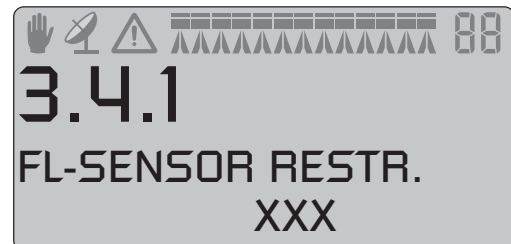

7 - Menu 3, Calibration

Menu 3.4.2 Simulated speed value

The "Simulated speed value" menu is used in 2 situations:

<ul style="list-style-type: none">• At standstill or when driving very slowly, while priming the boom.	This feature allows the sprayer to be stationary or to drive slowly and automatically get normal spray pressure to prime the boom.
<ul style="list-style-type: none">• If speed sensor is defective.	In this case the computer will assume that the sprayer is traveling at the speed selected in "Simulated speed value". The operator should keep the tractor constantly at this speed to maintain a good regulation with ability to handle changes in application rate and changes in sections. The selected speed should be appropriate also for headlands. If the speed is reduced at headlands, the resulting application rate will be higher than the selected value. Here is an example: If the operator selects the application rate to be 10.0 gpa and speed of 5 mph, and then reduces speed from 5 to 4 mph at headlands, the actual application rate will increase to 12.5 gpa.

Furthermore, when the spraying speed drops below the lowest speed value, where a spray job can begin when starting at headland (this speed is set by the HARDI® dealer), the speed will be simulated to maintain normal spray pressure, until the normal spraying speed is maintained.

 ATTENTION! Use this menu when a spray job has to be finished before fixing the defect sensors.

 ATTENTION! Recommended setting is 75-90% of spraying speed.

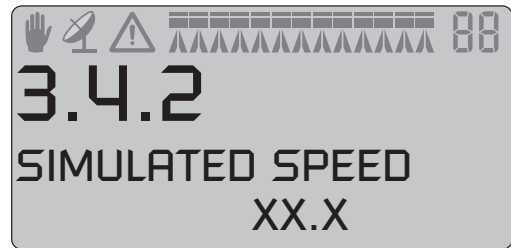

Menu 3.4.3 Nozzle size flow at 40 psi

At fault free operation, the controller uses the flow sensor and the pressure sensor to detect the nozzle size.

In case of flow sensor and/or pressure sensor faults, the nozzle flow can be typed in to obtain a more accurate regulation of the regulation valve. Use the arrow keys to select and change the digits in the display and press Enter to save.

If either the flow sensor or the pressure sensor is faulty, the nozzle cannot be identified. The controller stores the last detected nozzle size, and this value is then used.

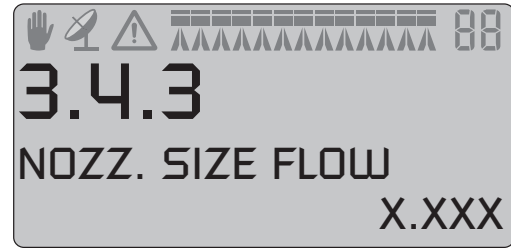

ATTENTION! If changing nozzles while a sensor is faulty, remember to type in the size of the new nozzle. Nozzle size is defined as flow at 40 psi as shown in the HARDI® nozzle catalogue. You can also find flow values in the table below.

Nozzle size	Flow (g/min)
0075-Pink	0.075
010-Orange	0.10
015-Green	0.15
020-Yellow	0.20
025-Purple	0.25
03-Blue	0.30
04-Red	0.40
05-Brown	0.50
06-Grey	0.60
08-White	0.80
10-Light blue	1.00
15-Light green	1.50



NOTE! The flow at 40 psi in the HARDI® nozzle catalogue is measured without nozzle filter and without PENTALET nozzle holder. The flow restriction from these two make the nozzle appear smaller.

Menu 3.4.4 Reserved

Reserved space (empty menu).

Menu 3.4.5 Type of nozzle

Select the nozzle type to be used when spraying by entering one of the two menus. Press Enter to save the nozzle type.



NOTE! Default value: Regular nozzle.



ATTENTION! Remember to change the gravity of the chemical mix in menu [3.5.1 Adjustment of specific gravity] if needed. For example, liquid fertilizer often weighs more than pesticide mix.

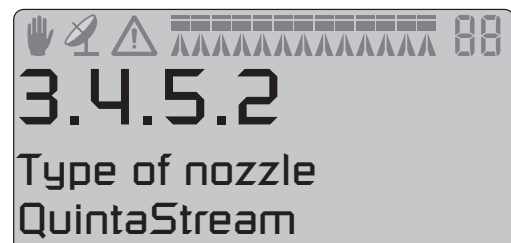
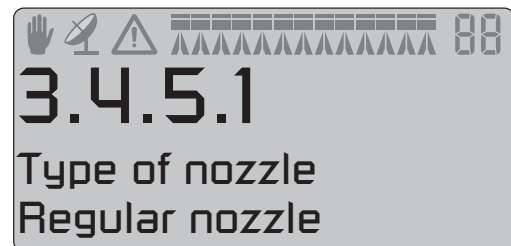

7 - Menu 3, Calibration

Menu 3.5 Tank gauge

General info

This menu item is only present if the HARDI® Tank Gauge is fitted. For increased accuracy, it is recommended to do the flow calibration before proceeding. See menu [3.2.3 Tank method].

The tank content is measured from the bottom of the main tank using a fluid pressure sensor.

The accuracy is affected by the sprayer being level. The readout of tank contents changes with changes in the height of the sprayer at the hitch point. Also, when driving on uneven or sloping ground, the readout will vary as the fluid pressure changes above the sensor.

If the tank gauge is replaced, it must be re-calibrated.

Menu 3.5.1 Adjustment

The correction factor for the specific gravity of the liquid sprayed can be set.



NOTE! Default value is 1.000.

For liquid fertilizers, the density is often higher than that of water mixed with pesticides. The specific gravity (or density) might be 1.3 times the value of water alone. The value in this case would be 1.300.

Method

1. Press to change value.
2. Use and to select the digit to be changed.
3. Change digit by pressing and .
4. Repeat until all digits are correct. Save setting by pressing .

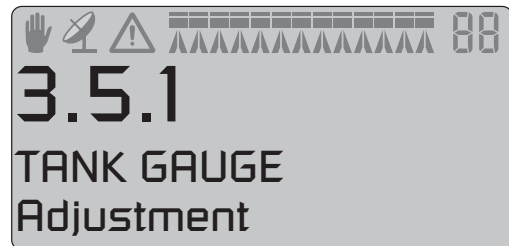

Menu 3.5.2 Calibration

Calibration of the HARDI® Tank Gauge is necessary to take into account the height of hitch point on the tractor and tire mounting. Skipping this may result in an inaccurate calculation of the tank contents.

Therefore, it is recommended to begin the custom calibration by connecting the sprayer to the tractor that will be used for spraying. A later change of tractor can affect the accuracy of the tank gauge.

To make a custom calibration of Tank Gauge, do the following:

1. Check that menu [3.2.1 Flow calibration] uses the correct PPU value corresponding to the sprayer's flow housing.
2. Go to menu [3.5.2 Calibration].
3. Fill the sprayer completely up to the filler lid in the top of the tank, with a known amount of water, using an externally calibrated flowmeter. Alternatively, weigh the sprayer before and after filling, and note the weight difference.
4. Press .

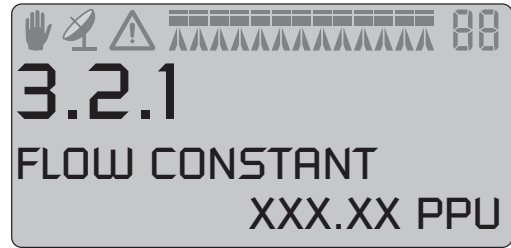

 **ATTENTION!** As the accuracy of the custom calibration is affected, it is of high importance that the externally calibrated flowmeter measures the correct quantity within a 2% deviation. Same accuracy of 2% must be kept if weighing the sprayer before/after filling is used.

 **WARNING!** Do not leave the sprayer while filling the tank, and keep an eye on the level indicator in order NOT to overfill the tank.

5. Press  after ensuring the sprayer is level. Refill the tank up to the tank lid if the sprayer is re-leveled.



Leveling the tractor and sprayer is of great importance, as the accuracy is directly affected!

If the same tractor will be used after customized calibration, it is not necessary for the sprayer itself to be level. But the whole vehicle, tractor and sprayer (A), need to be level. Alignment device (B) and spirit level (C) are helpful tools.

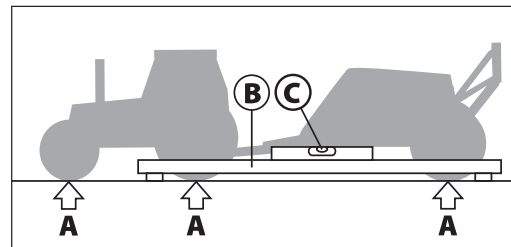

6. Engage the pump and set PTO revolutions at 540 rpm or 1000 rpm (depending on pump model).
7. Open all boom sections and empty the tank.

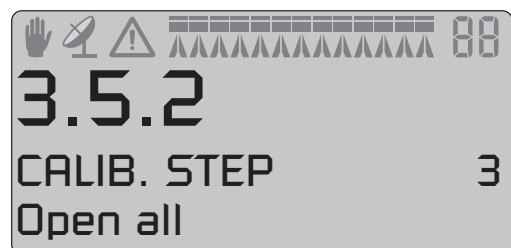

7 - Menu 3, Calibration

- The pulses from the flow sensor are logged as data points. During this session the screen shows: [xxxx] as the actual water level in millimeters and [yyyyyyy] is the number of pulses from the flowmeter.



i NOTE! The definition of having an empty tank is when no more spray comes out of the nozzles. Note that when empty, there are still about 6-10 quarts remaining in the sump of the tank.

- Press when the tank is empty.
- Correct the displayed volume to the actual volume sprayed out. Use the or and change digits with or . Actual volume is the volume filled with the calibrated flowmeter.
- Press . The new customized gauge table is calculated and the calibration of the HARDI® tank gauge is finished.



Menu 3.5.3 Tank selection

In this menu you can choose from a series of sprayer models, where the tank gauge has been precalibrated at the HARDI® factory. This calibration has been completed with the tractor and sprayer on level ground.

The available sprayer models are flashing in the 4th line of the display, showing sprayer model and its tank contents in gallons.

ATTENTION! If your filling place for the sprayer is not completely level, or there are other reasons to adjust the tank gauge sensor as described in "General Info" at the start of the description of menu 3.5, you should calibrate this sensor yourself to get a correct reading.

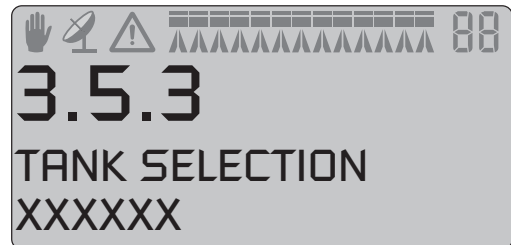

Whenever you have calibrated the tank gauge yourself, enter this menu and select "Custom tank".

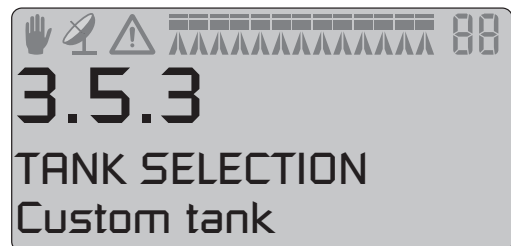

Menu 3.5.4 Offset empty

This menu is used for inspecting the frequency value for the tank gauge sensor, when the main tank is empty.

If the main tank is empty, press to accept this value.

In case the main tank is not empty, this menu can only be used to correct the "empty frequency" value, if the user knows this value.

ATTENTION! This can be useful for recalibrating the tank gauge to measure "empty tank" if the sensor gets dirty.



Menu 4.1 Measure

Tripmeter

This is a simple electronic tripmeter. You can measure distance when driving. Use  to reset the value.

If the sprayer width is entered in menu [4.1.3 Working width], the area can also be measured in menu [4.1.2 Area]. Use  to reset the value.

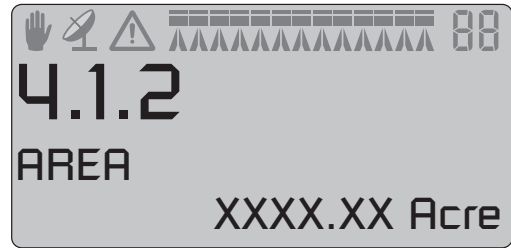
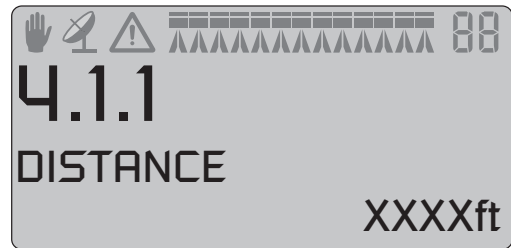

8 - Menu 4, Toolbox

Menu 4.2 Service interval

Menus and intervals

Service intervals and a nozzle check are programmed into the controller. This makes it easier for the operator to remember the service intervals. If the intervals are to be changed, contact your HARDI® service center for more information.

From the factory, the Controller is set up with three service reminders and one nozzle check reminder.

Menu	Interval (hours)	Action
[4.2.1 Check filters]	10	See sprayer instruction book, Maintenance.
[4.2.2 Grease boom]	50	See sprayer instruction book, Maintenance.
[4.2.3 Grease track and center]	250	See sprayer instruction book, Maintenance.
[4.2.4 Miscellaneous service]	-	Not defined from factory.
[4.2.5 Check nozzles]	50	Check flow rate. Change nozzles if more than 10% of rated flow.

Entering the above menu's will display the hours remaining until next service. The importer or dealer may have added a "Miscellaneous service" Interval. If no interval is set, "Not def." is shown, meaning that this interval is not yet defined.

Press  to register service or control, if displayed when switched on.

The warning  will remain present on the display, until the service interval is reset.

Service interval reset

To reset service interval, go to relevant interval menu as described above.

Press  to reset hour meter.

Press  to confirm.

Menu 4.3 Stopwatch

Use as timer

This clock can be used as a timer.

Press  to start and stop.

Press  to reset the time.



8 - Menu 4, Toolbox

Menu 4.4 Alarm clock

How to use the alarm clock

The clock can be set to give an alarm, when the time is reached.

Press the arrow keys to set the alarm time and confirm with .

Turn the alarm clock off by pressing .

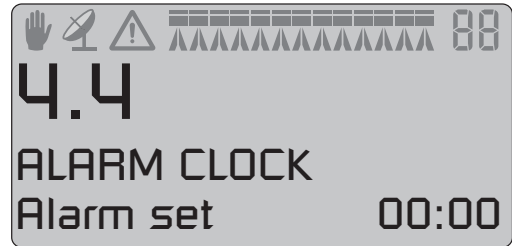

Menu 4.5 Test

How to make equipment test

All readouts for the sensors are in accumulated counts, i.e. one signal gives one count, except for optional (analog) sensors, which are read in milliamperes (mA).

Go to menu [4.5 TEST]. Choose the item to be tested and open the menu. Activate sensor and see if the signal is detected.

Menu 4.5.1 Flow calculation. Enter this menu to test flow sensor.

[4.5.1.1 Boom pressure]. Enter this menu to see flow sensor readout (psi).



Following menus:

[4.5.1.2 Reg valve calc]. Enter this menu to see regulation valve readout (psi).

[4.5.1.3 Pump calc flow]. Enter this menu to see pump flow readout (g/min).

[4.5.1.5 Reg valve calc]. Enter this menu to see regulation valve readout (g/min).

[4.5.1.6 Boom flow sensor]. Enter this menu to see flow sensor readout (g/min).

Menu 4.5.2 Speed. Enter this menu to test speed sensor.

[4.5.2 Speed]. Enter this menu to see speed readout.

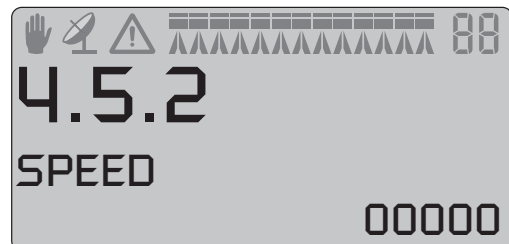

Menu 4.5.3 Optional sensor. Enter this menu to test optional sensors.

[4.5.3.1 Pressure]. Enter this menu to see pressure readout (mA).

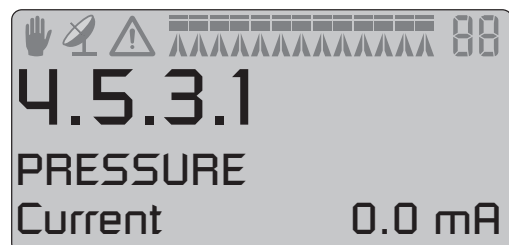

Following menus:

[4.5.3.2 Fan speed]. Enter this menu to see counts readout (counts/pulses).

[4.5.3.3 Tank gauge]. Enter this menu to see frequency readout (Hz).

[4.5.3.5 Regulation fb.]. Enter this menu to see regulation valve feedback readout (counts/pulses).

8 - Menu 4, Toolbox

Menu 4.5.4 Active switches

Enter this menu to test the number of activated switches.

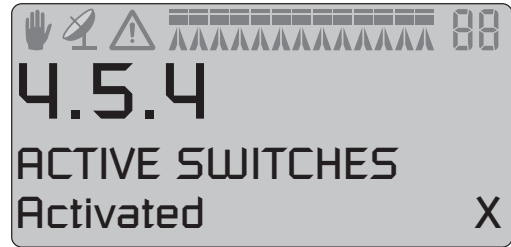

Menu 4.5.5 Regulat. sensors

Enter this menu to test the sensors for the DynamicFluid 4 (DF4) regulation.

[4.5.5.1 Boom pressure]. Enter this menu to see flow sensor readout (bar).

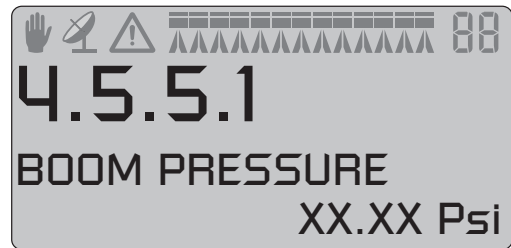

Following menus:

[4.5.5.2 Boom flow sensor]. Enter this menu to see flow readout (g/min).

[4.5.5.3 Pump RPM]. Enter this menu to see pump speed readout (rpm).

[4.5.5.4 FlexCapacity RPM]. Enter this menu to see flex capacity pump speed readout (rpm).

[4.5.5.5 Regulation valve]. Enter this menu to see regulation valve readout (degrees).

[4.5.5.7 Reserved]. Reserved menu space.

[4.5.5.8 Reserved]. Reserved menu space.

[4.5.5.9 Regulator state]. Enter this menu to see regulator state readout (counts/pulses).

Menu 4.6 Speed simulation

How to use speed simulation

Speed may be simulated for several reasons as described in the sections below.

When setting the simulated speed in this menu, the value will remain valid, until the Controller is restarted or the value is set to "00".

Troubleshooting

If you are getting an incorrect spraying output, or there is too much deviation in the output or in other equipment settings, the driving speed sensor may be providing incorrect signals for several reasons.

If the need for troubleshooting has occurred, you can simulate the driving speed by setting the speed value in this menu. This way you can exclude any speed sensor faults at this time.

If you are still getting incorrect spray output or settings, you must continue your troubleshooting elsewhere on the sprayer.

Verification

The speed simulation is helpful, when calculating the boom flow and pressure after having chosen the desired spray output.

Service

When carrying out a service check of the sprayer, or after a longer period of standstill, the speed can be simulated to avoid having to drive around in the field to check the equipment settings for spraying.



Menu 5.1 Print

What you can print

The following can be printed via the 12 volt printer.

Menu 5.1.1 Register number

Enter this menu to print a specific register with spraying data. By using the arrow keys, the register number in the top right corner can be adjusted. When the desired register number appears, press  to print out the data register.

Now choose a new register number to print this data out, if needed.



Menu 5.1.2 All registers

Enter this menu to print all registers 1-99 with spraying data at once. Only active ones will be printed.

Press  to print out the data.



Menu 5.1.3 Configuration

Enter this menu to print all the parameters of the controller at once.

Press  to print out the data.

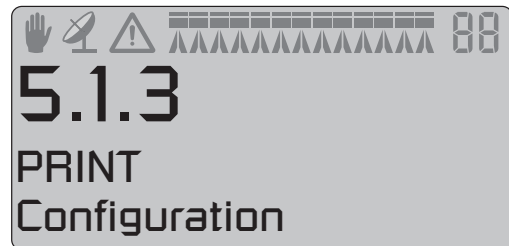

 NOTE! While the data is being printed out, the bottom line in the display reads "Printing".

Two examples of printouts are shown here.

- To the left is a printout of a specific register.
- To the right is a printout of the configuration.

HARDI HC5500		HARDI HC5500 - configuration	
Serial number	06023892	Serial number	06023892
Register	12/ERIK	SW version	3.38
Volume applied	0 L	*****	
Area	0.00 ha	1	Daily settings
Travelled spray distance	0.0 km	1.1	Volume rate
Start date	00.00.00	1.2	Tank contents
Start time	00:00	1.3	select register
Stop date	00.00.00	2	Setup
Stop time	00:00	2.1	Display readout
Time used (spraying time)	00:00	2.1.1	Pressure
Work rate	0.00 ha/h	2.1.2	Flow rate
Average spray speed	0.0 km/h	2.2	AUTO functions
Max. spray speed	0 L/ha	2.2.1	Auto ON/OFF
Average volume rate	0 L/ha	2.2.2	Foam marker
Date printed	19.02.08	2.2.3	Dual line
Time printed	18:35	2.3	VSA/Remote
Notes:		2.4	set clock
		2.5	Alarms
		2.5.1	volume rate
		2.5.2	Tank contents
		2.5.3	Pressure
		2.5.3.1	High limit
		2.5.3.2	Low limit
		2.5.4	Fan speed
		2.5.4.1	High limit
		2.5.4.2	Low limit
		2.5.5	Speed
		2.5.5.1	Maximum value
		2.5.5.2	Minimum value
		2.5.6	Audio level
		2.5.7	sections off
		3	calibration
		3.1	Speed
		3.1.1	Sprayer
		3.1.1.1	Constant
		3.1.2	Tractor
		3.1.2.1	Constant
		3.1.3	Radar
		3.1.3.1	constant
		3.2	Flow
		3.2.1	Flow constant
		3.3	Boom
		3.3.1	width
		3.3.2	no. of sections
			nozzles/section
			7; 7; 9;10; 0

9 - Menu 5, Logbook

Menu 5.2 Data dump

How to dump data

Enables data dump to an office printer via a computer. This could be done, for example, by using the Hyper Terminal function in Microsoft Windows.

Note that the Hyper Terminal has to be activated, and a communication cable (HARDI® item no. 72271600) and a 12 volt power supply to the Controller and Spray Box III is needed.

The Hyper Terminal baud rate should be set at one of the following before transmitting data:

- 19200 baud
- 9600 baud (default for HC 5500)
- 4800 baud
- 2400 baud
- 1200 baud

If only the display unit is to be removed from the tractor, a 12 volt power supply cable (HARDI® item no. 72244500) is needed. The following can be printed to an office printer:

Menu 5.2.1 Raw data

Enter this menu to dump the data at once without a column header.

Press  to print out the data.

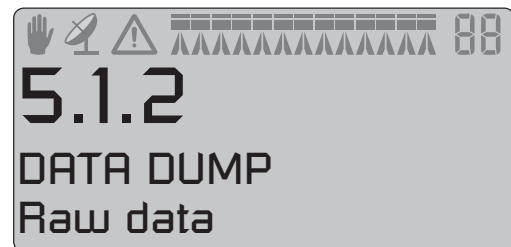

Menu 5.2.2 With header

Enter this menu to dump the data at once. This print method permits the data to be set up with a column header.

Press  to print out the data.

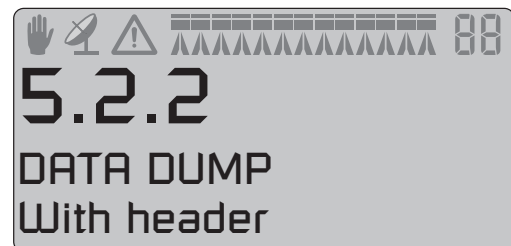

Menu 5.2.3 Configuration

Enter this menu to send the data to a computer at once. The data can then be set up handled in a suitable computer program.

Connect a computer with a cable into one of the blue 9-pin sockets on the back side of the controller.

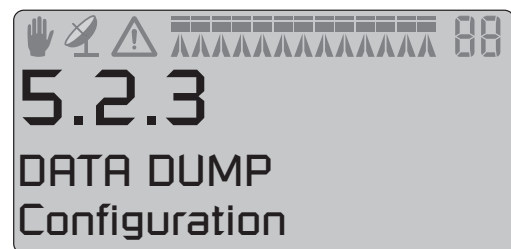

NOTE! While the controller is dumping data, the bottom line in the display reads "Dumping".

Off-season maintenance

Off-season storage

When the tractor and sprayer is parked, disconnect the power supply to the Spray Box. This will stop the system from using power.

The Controller and Spray Box should be protected from moisture. They should be removed, if the tractor does not have a cabin.

Emergency Operation

In an emergency situation

The Spray Box III can operate the control unit without the Controller.

If you suspect the Controller is faulty, disconnect it from the Spray Box. Spraying can now be continued.

If the fault persists, it is not because of Controller errors.

11 - Fault finding

Operational Problems

Operational faults

FAULT	PROBABLE CAUSE	CONTROL/REMEDY
Area is not being measured.	Boom width or speed constant have not been entered. Missing speed sensor. The controller clock is not set.	Enter the values in menu [3.3.1 Width] and [3.1 Speed calibration]. Check the sensor using menu [4.5.2 Speed], check the cable to the sensor for damage. If necessary, replace the sensor. Check sensor location [3.1 Speed calibration]. Set the clock in menu [2.4 Set clock] to enable the controller registers.
The volume rate (gpa) is continuously displayed at "0".	Constant has not been entered. Pulses of the flow meter are not reaching the sprayer control unit.	Enter constant in menu [3.2.1 Flow calibration]. Check wiring. Check the impeller of the flow meter, using menu [4.5.1 Flow] - it may be stuck.
The volume rate display is not correct.	The flow meter is not working properly. The area is not being registered.	Test the flowmeter using menu [4.5.1 Flow]. Check boom width and adjust if necessary. Re-calibrate speed [3.1 Speed].
The intended volume rate cannot be reached. The volume is below the preset rate.	The pressure motor has been incorrectly poled. The rate is controlled downwards instead of upwards. The pump cannot deliver the required amount. The filters are blocked. Wrong flow PPU.	Check the control by using the +/- keys in manual mode. Change the control motor connections if necessary. Increase PTO speed. Change to a lower gear. Clean the filter. Check PPU using menu [3.2 Flow calibration].
The volume rate lies above the preset rate.	The pressure motor has been incorrectly poled. The rate is controlled downwards instead of upwards. The return flow from the pressure motor to the tank cannot take superfluous quantity.	Check the control by using the +/- keys in manual mode. Change the control motor connections if necessary. Check the tube system. Reduce the power of the pump (lower PTO speed, higher gear).
Volume application rate is not stable when only one or two boom sections are open.	Flow below minimum frequency of flow sensor.	Set pressure manually when spraying with fewer sections. Install a pressure sensor. Below 5 Hz from the flow sensor will result in the system switching to pressure based sensing for volume application rate.

Mechanical faults

FAULT	PROBABLE CAUSE	CONTROL/REMEDY
No speed readout.	Incorrect speed sensor location chosen. Defective sensor or cable.	Select the correct sensor on Sprayer, Tractor or Radar in menu [3.1.1, 3.1.2 or 3.1.3]. Check sensor using menu [4.5.2 Speed].
Error message that fuse is active.	Short circuit in system. The Spray box has 3 thermal fuses: Fuse 1 = Section valves to left side of center and center switch. Fuse 2 = Section valves to right of center switch. Fuse 3 = Short circuit in options and pressure regulation.	Turn power OFF and locate problem. When fuses has cooled down the system can be powered on again.
Error message "Low voltage".	Voltage below 9 Volts.	Check battery and connections.
Speed readout not stable.	Perforated wheel sensor plate fitted back the front. Speed sensor set to close to upper or lower sides of perforated wheel sensor plate.	Relocate sensor.

Operation when a sensor fails

When one of the sensors for pump speed, flow or pressure fails, the system will work in a limp-home mode with reduced, although acceptable performance. One of the alarms between ID numbers 5 and 9 will be triggered in the controller display. See also the section "Alarm list" for explanation of these alarms.



ATTENTION! In the auto mode, the system will not work with 2 sensors failing, so the operator should repair the failing sensor as soon as possible.

Pressure regulation angle sensor works both as a feed back to the computer and as the end stop switch. If the angle sensor fails, the operator can continue turning the regulation valve passing the completely closed position.

Failures in the sensors below will cause an inaccurate calculation of the volume rate when spraying. In order to be able to end a spray job when one or more sensors fail, see instructions in the table below.

Pump speed	Flow	Pressure	Driving speed	Valve angle	Mode for regulation	Action for operator
Use	Use	Use	Use	Use	Full performance	None
Defect	Use	Use	Use	Use	Reduced performance	None
Ignore	Defect	Use	Use	Use	Reduced performance	Setup new nozzle size. See menu [3.4.3 Nozzle size flow at 3 bar].
Defect	Defect	Use	Use	Use	Reduced performance	Setup new nozzle size. See menu [3.4.3 Nozzle size flow at 3 bar].
Ignore	Use	Defect	Use	Use	Reduced performance	Setup new nozzle size. See menu [3.4.3 Nozzle size flow at 3 bar].
Defect	Use	Defect	Use	Use	Reduced performance	Setup new nozzle size. See menu [3.4.3 Nozzle size flow at 3 bar].
Use	Use	Use	Defect	Use	Spray at constant driving speed	Keep sprayer at constant driving speed. Type in simulated sprayer speed, see menu [3.4.2 Simulated speed value].
Ignore	Defect	Defect	Ignore	Use	Manual only	Adjust pressure according to mechanical pressure gauge.
Ignore	Ignore	Ignore	Ignore	Defect	Manual only. Regulation valve can pass end stop, i.e. when continuing after it is closed, it opens again*.	Adjust pressure according to mechanical pressure gauge. Check if passing end stop of valve*. Compensate for pressure changes due to sections ON/OFF.

* The regulation valve is equipped with 4 LED lights:

- 2 red lights indicating "Out of working range"
- 1 yellow light indicating "Valve closed"
- 1 green light indicating "Open working range"

11 - Fault finding

Fluid system test

A way to troubleshoot the sprayer is to complete these steps to check the fluid system for defects.

1. Close the main ON/OFF valve.
2. Close the regulation valve by pushing up the yellow button on the Spray Box III to increase the pressure. A yellow diode lights up on the valve when it is closed.
3. Close the agitation valve.
4. Close the pressure filter bypass valve.
5. Set pump speed between 250 and 300 rpm with tractor engine in idle.
6. Now all liquid from the pump should pass the flow sensor for the spray boom.
7. Pump condition and possible internal valve leakages can be checked by comparing with
 - menu [4.5.1.3 Pump calc flow]. This menu shows the calculated flow from the pump.
 - menu [4.5.1.6 Boom flow sensor]. This menu shows the actual measured flow through the flow sensor.

Alarm list

ID NO.	TYPE	TEXT IN DISPLAY	PROBABLE CAUSE	CONTROL/REMEDY
1	Alarm	Alarm:VolumeRate	Volume rate deviation is higher than the defined value.	Adjust settings in menu 2.5.1.
2	Alarm	Alarm:Tank cont.	Tank contents is less than the defined value.	Adjust settings in menu 2.5.1.
3	Alarm	Alarm:PressureHi	Boom pressure is higher than the defined value.	Adjust settings in menu 2.5.3.1. Decrease driving speed or change to a bigger nozzle.
4	Alarm	Alarm:PressureLo	Boom pressure is lower than the defined value.	Increase driving speed (if safe) or change to a smaller nozzle. Adjust settings in menu 2.5.3.2.
5	Alarm	Alarm:Rpm Hi	Speed for the TWIN blower is higher than the defined value.	Adjust settings in menu 2.5.4.1.
6	Alarm	Alarm:Rpm Lo	Speed for the TWIN blower is lower than the defined value.	Adjust settings in menu 2.5.4.2.
7	Alarm	Alarm:Speed Max.	The driving speed is higher than the defined value.	Adjust settings in menu 2.5.5.1.
8	Alarm	Alarm:Speed Min.	The driving speed is lower than the defined value.	Adjust settings in menu 2.5.5.2.
9	Alarm	Sections: OFF!	Main ON/OFF is switched ON, and one or more spray sections are OFF.	Note that one or more sections are switched OFF.
10	Alarm	SENSOR ALARM Regvlv sens.miss	Feedback sensor for the regulation valve is deviating, disconnected or missing.	Check installation of this sensor.
11	Alarm	SENSOR ALARM Flow sens. miss	Boom flow sensor is disconnected or missing.	Check installation of this sensor.
12	Alarm	SENSOR ALARM Press.sens.miss	Boom pressure sensor is disconnected or missing.	Check installation of this sensor.
13	Alarm	SENSOR ALARM RPM sens. fail	Sensor for pump speed (rpm) is disconnected or missing.	Check installation of this sensor.
14	Alarm	Regulation valve Motor fail	Problem with regulation valve control.	Electric motor for regulation valve has an internal failure, or the wiring between motor and valve is broken.
15	Alarm	SENSOR ALARM 5V supply	Short circuit of a sensor with 5 volt supply.	Contact your HARDI® service center.
16	Alarm	SENSOR ALARM 12V supply	Short circuit of a sensor with 12V supply.	Contact your HARDI® service center.

Alarm warnings are flashing in the bottom line of the display - 3 seconds ON, 3 seconds OFF. The flashing alarm and an optional alarm sound will stop, when  is pressed, or when the cause of the alarm has been corrected (non-alarm condition).

If the alarm is stopped by pressing , the alarm will be active again when going from alarm condition to non-alarm condition and back to alarm condition again.

Only the first incoming alarm will flash in the display. The next alarm will flash only after the first alarm is stopped by pressing . The alarms have no order of priority.



NOTE! Alarms no. 10 - 14 relate to the DynamicFluid 4 (DF4) system on the sprayer.

Testing and fine tuning

Fine tuning the flow constant - PPU

Calibration of the flow sensor is carried out with clean water. However, small changes may occur when adding pesticides or fertilizer. This will effect the final readings. This is typically noted when the volume shown on the display does not equal the actual known volume that was sprayed out. The formula below can be used to “fine tune” the flow sensor PPU.

$$\text{New PPU} = \frac{\text{Original PPU} \times \text{Displayed Volume}}{\text{Sprayed Volume}}$$

For example, the spray tank is filled with 1000 gallons of spray liquid.

When sprayed out, the display showed a total of 900 gallons. (Original PPU = 485.0)

$$\text{New PPU} = \frac{485\text{PPU} \times 900\text{gallons}}{1000\text{gallons}} = 436.5\text{PPU}$$

Note the relation is inverse

- To raise the displayed volume, the PPU is lowered.
- To lower the displayed volume, the PPU is raised.

Pin & Wire connection

AMP Super Seal	Box	Color coding
2	Positive	Brown
3	Signal	Blue
1	Negative	Black

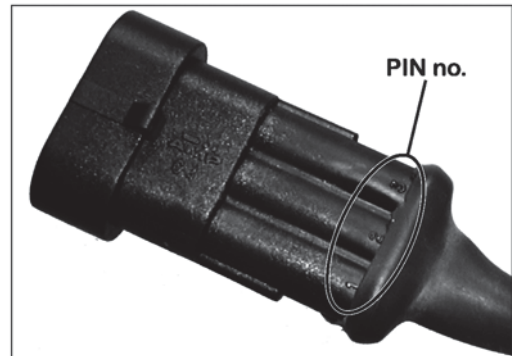

12 - Testing and fine tuning

Testing flow sensor

- BROWN wire to positive of 12 volt battery.
- BLACK wire to negative.
- BLUE wire to multimeter positive.

1. Check the rotor turns freely.
2. Each vane in the rotor has a magnet in it with the pole facing out. Check that the 4 magnets are present.
3. Use a magnet to check that every second magnet in the rotor has the same pole orientation. The rotor magnets must be N- S - N - S.
4. Connect negative from multimeter to negative of battery.
5. Set multimeter to DC volt.
6. By turning the mill wheel slowly, this will register approx. 8.0 +/- 1 volt with the diode on, and 0.3 +/- 0.1 volt with the diode off with every second magnet.

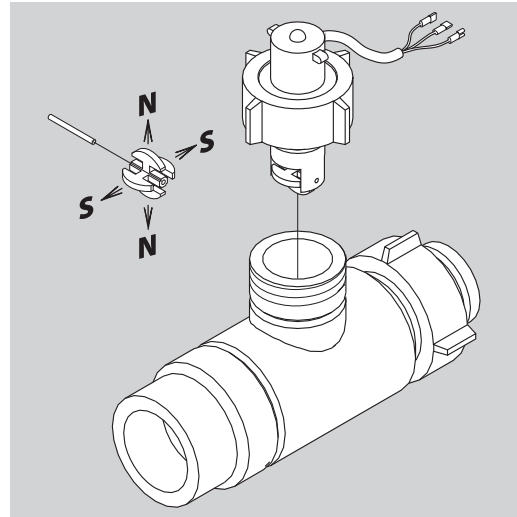

Testing speed sensor

- BROWN wire to positive of 12 volt battery. BLACK wire to negative.
- BLUE wire to multimeter.

1. Connect negative from multimeter to negative of battery.
2. Set multimeter to DC volt.
3. Bring a metallic object within 1/8" to 3/16" (3 to 5 mm) from the sensor. This will register 1.4 +/- 0.2 volt and the diode will turn on.
4. By removing the object, this will register 12.0 +/- 1.0 volt. Diode is OFF.

Specifications

Electrical properties

Supply voltage:	12 Volt DC
Controlled shutdown "low battery":	9 Volt DC
Maximum supply:	16 Volt DC
Maximum peak:	28 Volt DC
Ambient temperature:	23°F to 158°F (- 5°C to + 70°C)
Memory:	Flash PROM non-volatile
Digital sensors (option 2, 3 and 4):	Square signal
Frequency:	0.5 Hz to 2 kHz
Trigger high:	4.0 to 12.0 Volt DC
Trigger low:	0.0 to 2.0 Volt DC
Analog sensors (option 1):	
Supply:	12 V
Input:	4 to 20 mA
Minimum driving speed for volume regulation:	0.3 mph (0.5 km/h)

Flow ranges for flow sensors

Housing	Housing identification (A)	Flow range g/min.	Orifice mm	PPU value
S/67	One outside groove	2 - 30	13.5	485.00
S/67	No grooves	4 - 70	20.0	225.00
S/67	Two outside grooves	20 - 160	36.0	60.00

Pressure drop over the 13.5 mm orifice is 14.5 psi at 39.6 g/min.



NOTE! Flow housings with no grooves or one groove are the most common ones used with HC 5500.

Baud rate

The Controller is capable of running the following baud rates when communicating with an external component via the RS232 connectors:

- 19200 baud
- 9600 baud (default for HC 5500)
- 4800 baud
- 2400 baud
- 1200 baud

13 - Technical specifications

Materials and Recycling

Disposal of electronics

Cardboard: Recyclable up to 99% and therefore should be disposed into the waste collection system.

Polyethylene: Recyclable.

When the operating unit has completed its working life, it must be thoroughly cleaned. The synthetic fittings can be incinerated. The printed circuit boards and metallic parts can be scrapped. Follow local regulations for waste disposal.

Packaging information

Materials used for packaging are environmentally compatible. They can be safely deposited or they can be burned in an incinerator.

Notes

Table for recording values

Menu	Function	Value 1	Value 2	Value 3
[3.2.1 Flow constant]	Flow PPU			
[3.1.X.1 Speed constant]	Speed PPU			
[3.4 Regulation constant]	%			

Warranty policy and conditions

HARDI® NORTH AMERICA INC. , 1500 West 76th Street, Davenport, Iowa, USA hereinafter called "HARDI®", offers the following limited warranty in accordance with the provisions below to each original retail purchaser of its own manufacturer, from an authorized HARDI® dealer that such equipment is at the time of delivery to such purchaser, free from defects in material and workmanship and that such equipment will be warranted for a period of one year from the time of delivery to the end user, providing the machine is used and serviced in accordance with the recommendations in the Operator's Manual and is operated under normal farm conditions.

1. This limited warranty is subject to the following exceptions:
 - a) This warranty will be withdrawn if any equipment has been used for purposes other than for which it was intended or if it has been misused, neglected, or damaged by accident, let out on hire or furnished by a rental agency. Nor can claims be accepted if parts other than those manufactured by HARDI® have been incorporated in any of our equipment. Further, HARDI® shall not be responsible for damage in transit or handling by any common carrier and under no circumstances within or without the warranty period will HARDI® be liable for damages of loss of use, or damages resulting from delay or any consequential damage.
2. We cannot be held responsible for loss of livestock, loss of crops, loss because of delays in harvesting or any other expense or loss incurred for labor, supplies, substitute machinery, rental for any other reason, or for injuries either to the owner or to a third party, nor can we be called upon to be responsible for labor charges, other than originally agreed, incurred in the removal or replacement of components.
3. The customer will be responsible for and bear the costs of:
 - a) Normal maintenance such as greasing, maintenance of oil levels, minor adjustments including the boom.
 - b) Transportation of any HARDI® product to and from where the warranty work is to be performed.
 - c) Dealer travel time to and from the machine or to deliver and return the machine from the service workshop for repair unless otherwise dictated by state law.
 - d) Dealer traveling costs.
4. This warranty will not apply to any product which is altered or modified without the express written permission of the HARDI® Service and Engineering Departments and/or repaired by anyone other than an Authorized HARDI® Dealer.
5. Warranty is dependent upon the strict observance by the purchaser of the following provisions:
 - a) That this warranty may not be assigned or transferred to anyone.
 - b) That the Warranty Registration Certificate has been correctly completed by dealer and purchaser with their names and addresses, dated, signed and returned to the appropriate address as given on the Warranty Registration Certificate within 30 days of delivery to the purchaser.
 - c) That all safety instructions in the operator's manual shall be followed and all safety guards regularly inspected and replaced where necessary.
6. No warranty is given on second-hand products and none is implied.
7. HARDI® reserves the right to incorporate any change in design in its products without obligation to make such changes on units previously manufactured.
8. The judgement of the HARDI® Service Department in all cases of claims under this warranty shall be final and conclusive and the purchaser agrees to accept its decisions on all questions as to defect and the repair or exchange of any part or parts.
9. No employee or representative is authorized to change this warranty in any way or grant any other warranty unless such change is made in writing and signed by the CEO in the Davenport office. Approval of warranty is the responsibility of the HARDI® Service Department.

14 - Warranty

10. Any warranty work performed which will exceed \$1000.00 MUST be approved IN ADVANCE by the Service Department. Warranty claims filed without prior approval will be returned.
11. Claims under this policy MUST be filed with the HARDI® Service Department within thirty (30) days of when the work is performed or warranty shall be void unless prior arrangements are made.
12. Parts which are requested for return by the HARDI® Service Department must be returned prepaid within thirty (30) days for warranty settlement.
13. Warranty claims must be COMPLETELY filled out including part numbers and quantities or claims will be returned to the submitting dealer.

DISCLAIMER OF FURTHER WARRANTY

THERE ARE NO WARRANTIES, EXPRESSED OR IMPLIED, EXCEPT AS SET FORTH ABOVE. THERE ARE NO WARRANTIES WHICH EXTEND BEYOND THE DESCRIPTION OF THE PRODUCT CONTAINED HEREIN. IN NO EVENT SHALL THE COMPANY BE LIABLE FOR INDIRECT, SPECIAL OR CONSEQUENTIAL DAMAGES (SUCH AS LOSS OF ANTICIPATED PROFITS) IN CONNECTION WITH THE RETAIL PURCHASER'S USE OF THE PRODUCT.

Index**A**

Alarm clock, 56
Alarm list, 69
Alarms, 37
Auto functions, 34

B

Boom calibration, 46

C

Calibrated tank gauge, 52
Calibration, 41
Connect a computer, 62

D

Daily settings, 25
Data dump, 62
Display readout, 31
DynamicFluid 4 regulation, 58

E

Emergency operation, 65
Equipment test, 57

F

Flow calculation, 57
Flow calibration, 43
Flow constant, 43
Flow housing, 73
Flow ranges, 73
Flow sensor, 72, 73
Foam marker, 34
Foot pedal remote, 24

I

Installation brackets, 21

K

Keys for controller, 15

M

Main ON/OFF, 34
Manual dosage, 28

N

Nozzle method, 44
Nozzles per section, 46

O

Operator Safety, 9
Optional sensor, 57

P

Power supply, 22
PPU, 71, 73
Pressure regulation, 14
Print, 61
Printer, 22

R

Recording values, 75
Register selection, 30

S

Service interval reset, 54
Service intervals, 54
Specific gravity, 50
Specifications, 73
Speed calibration, 41
Speed sensor, 23, 57, 72
Speed simulation, 59
Stopwatch, 55
Storage, 63
Switches for Spray Box III, 18
Symbols, 17

T

Tank contents, 29
Tank gauge, 50
Tank method, 45
Test, 57
Tractor installation, 21
Trip meter, 53

V

Volume rate, 27

W

Wire connection, 71



HARDI® North America Inc.

1500 West 76th St - Davenport, IA 52806

Ph: (563) 386-1730

Customer Service Email: custserv@hardi-us.com

Email: info@hardi-us.com

Website: www.hardi-us.com