



The Sprayer

Operator's Manual

**COMMANDER
4500/5500/7000
TWIN FORCE**

Instruction book

67024503 - Version 1.00

US - 03.2020

**COMMANDER
4500/5500/7000
TWIN FORCE**

Instruction book

67024503 - Version 1.00

US - 03.2020

| | |
|--|-----------|
| 1 - Welcome | |
| Welcome letter | 9 |
| 2 - General Safety Instructions | |
| Obligations and Liability | 11 |
| Comply with the Instruction Book | 11 |
| Before First Use of the Sprayer | 11 |
| Obligations of the Operator | 12 |
| Risks in Handling the Sprayer | 12 |
| Disclaimer | 12 |
| Organizational Measures | 13 |
| Personal Protective Equipment | 13 |
| Representation of Safety Symbols | 14 |
| Explanation of Symbols | 14 |
| General Info | 14 |
| Warning Labels On The Sprayer | 15 |
| Explanation of Labels | 15 |
| Safety and Protection Equipment | 17 |
| Safety at Start up | 17 |
| Faulty Safety Equipment | 17 |
| Additional Safety Instructions | 17 |
| Local poison information center | 18 |
| 3 - Description | |
| General Info | 19 |
| View | 19 |
| View | 20 |
| Identification Plates | 21 |
| Sprayer Use | 23 |
| Steel Frame | 23 |
| Tanks | 23 |
| Lifetime | 23 |
| Liquid System | 24 |
| Pump | 24 |
| Valves and Symbols | 24 |
| DynamicFluid4 Pressure Regulation | 26 |
| Filters | 28 |
| EasyClean Filter | 28 |
| CycloneFilter | 29 |
| TurboFiller | 30 |
| Rinsing Tank | 31 |
| Clean Water Tank | 31 |
| Diagram - Basic Liquid System | 32 |
| Diagram - Liquid System with Optional Extras | 33 |
| TWIN Air System | 34 |
| General Info | 34 |
| Hydraulic System | 35 |
| Hydraulic Blocks | 35 |
| Spray Boom | 37 |
| Spray Boom and Terminology | 37 |
| Standard Boom Features | 37 |
| Available Working Widths | 38 |

Table of Contents

| | |
|--|-----------|
| Other Equipment | 39 |
| Control Units in the Tractor | 39 |
| Platform | 40 |
| Nozzle Pressure Gauge | 40 |
| Canister for Pesticide Information | 40 |
| ChemLocker | 41 |
| SafetyLocker | 41 |
| Drawbars | 42 |
| Hydraulic Support Leg CM5500/7000 | 42 |
| SafeTrack | 42 |
| Tank Level Indicator | 43 |
| External Cleaning Device | 44 |
| Night Spraying Light | 44 |
| Paralift Lock Brackets | 45 |

4 - Sprayer Setup

| | |
|--|-----------|
| General Info | 47 |
| Unloading the Sprayer from the Truck | 47 |
| Pulling the Sprayer at the Tie Down Points | 47 |
| Before Putting the Sprayer Into Operation | 48 |
| Jack Up the Sprayer | 48 |
| Hydraulic Support Leg CM 5500/7000 | 49 |
| Transmission Shaft | 50 |
| Operator Safety | 50 |
| PTO Installation | 50 |
| Mechanical Connections | 51 |
| Hose Package Support | 51 |
| SafeTrack Potentiometer Connection | 51 |
| Hydraulic System | 52 |
| General Info | 52 |
| Requirements for Tractor | 52 |
| Open and Closed Center Hydraulics | 53 |
| Electrical Connections | 54 |
| Power Supply | 54 |
| Road Safety Kit | 54 |
| Installation of Control Unit Brackets | 55 |
| Speed Sensor for Sprayer | 56 |
| Liquid System | 57 |
| CycloneFilter | 57 |
| Spray Boom | 58 |
| Boom Movements When Spraying | 58 |
| Mechanical Adjustment of Guide Rods | 58 |
| Adjustment of Trapeze Damping | 60 |
| Adjustment of Boom Folding Speed | 62 |
| Damping of Boom Folding Speed | 63 |
| TWIN Air System | 64 |
| Adjusting the Air Assistance | 64 |
| Setting the Air Speed - Rules of Thumb | 64 |
| Angling of Air and Spray Liquid - Rules of Thumb | 65 |
| Spray Tips | 66 |
| Track Width, Axles and Wheels | 67 |
| Altering the Track Width (Adjustable Axle) | 67 |
| Changing the Wheel Offset | 67 |
| Dual Tire Setup (Optional) | 68 |

5 - Operation

| | |
|--|-----------|
| General info | 69 |
| Symbols for Valves | 69 |
| Spray Boom | 70 |
| Safety Info | 70 |
| Operating the Grip | 70 |
| Maneuvering of the Boom | 71 |
| Operating the Control Unit While Spraying | 72 |
| Night Spraying Light | 73 |
| Indicator for Angling of TWIN Air System | 74 |
| Steering | 75 |
| Driving Technique for SafeTrack | 75 |
| Liquid System | 76 |
| Filling/Washing Location Requirements | 76 |
| Filling of Water | 76 |
| Filling Through Tank Lid | 77 |
| Main Tank Quick Fill | 77 |
| Filling of Rinsing Tank | 77 |
| Filling of Clean Water Tank | 78 |
| Safety Precautions - Crop Protection Chemicals | 79 |
| Filling chemicals through tank lid | 79 |
| Operating the TurboFiller | 80 |
| Filling Liquid Chemicals Using the TurboFiller | 82 |
| Filling Powder Chemicals Using the TurboFiller | 83 |
| Agitation Before Resuming a Spray Job | 84 |
| TurboFiller Rinsing | 84 |
| Before Returning to Refill the Sprayer | 85 |
| Parking the Sprayer | 85 |
| Quick Reference - Operation | 85 |
| Cleaning | 86 |
| General Info | 86 |
| Quick Reference - Cleaning | 87 |
| Standard Cleaning | 88 |
| Cleaning and Maintenance of Filters | 88 |
| Use of Cleaning Agent | 88 |
| Use of Rinsing Tank and Rinsing Nozzles | 89 |
| D. Full Internal Cleaning (Soak Wash) | 92 |
| Technical Residue | 93 |
| Using the Drain Valve | 93 |

6 - Maintenance

| | |
|--|-----------|
| Lubrication | 95 |
| General Info | 95 |
| Recommended Lubricants | 95 |
| Grease Nipple | 96 |
| Grease Gun Calibration | 96 |
| Lubrication and Oiling Plan (Boom Width: 80' - 100') | 97 |
| Lubrication and Oiling Plan (Boom Width: 120') | 98 |
| Lubrication Plan - Trailer / Paralift | 99 |
| Lubrication and Oiling Plan - PTO | 100 |
| Greasing the Pump | 101 |

Table of Contents

| | |
|--|------------|
| Service and Maintenance Intervals | 102 |
| Tightening Bolts and Nuts | 102 |
| Tightening Hydraulic Hoses | 103 |
| 10 Hours Service - Spraying Circuit | 103 |
| 10 Hours Service - EasyClean Filter | 104 |
| 10 Hours Service - In-Line Filter | 104 |
| 10 Hours Service - CycloneFilter | 105 |
| 10 Hours Service - Nozzle Filters | 105 |
| 10 Hours Service - Hydraulic Oil Level | 105 |
| 50 Hours Service - Greasing the Pump | 106 |
| 50 Hours Service - Wheel Nuts | 106 |
| 50 Hours Service - Tire Pressure | 106 |
| 50 Hours Service - Gearbox for TWIN System, Bolts | 107 |
| 50 Hours Service - Transmission Shaft (PTO) | 107 |
| 50 Hours Service - Hydraulic Oil for TWIN System, Filter Change | 107 |
| 50 Hours Service - Gearbox for TWIN System, Oil Change | 108 |
| 100 Hours Service - Check / Tighten Steering | 109 |
| 100 Hours Service - Re-tightening the Spray Boom | 109 |
| 250 Hours Service - Hydraulic Circuit | 110 |
| 250 Hours Service - Hoses and Tubes | 110 |
| 250 Hours Service - Wheel Bearings | 110 |
| 500 Hours Service - Hydraulic Oil for TWIN System, Filter Change | 110 |
| 500 Hours Service - Gearbox for TWIN System, Oil Change | 110 |
| 1000 Hours Service - Hydraulic Oil for TWIN system, Oil Change | 111 |
| 1000 hours service - Wheel bearings | 113 |
| Occasional Maintenance | 114 |
| General Info | 114 |
| Lifting and Removing the Pump | 114 |
| Pump Valves and Diaphragms Replacement | 115 |
| Speed Transducer for Pump | 116 |
| Level Indicator Adjustment | 116 |
| Level Indicator Wire Replacement | 117 |
| Drain Valve Seal Replacement | 117 |
| Feed Pipe Clamp Assembly | 118 |
| Feed Pipe Snap-Lock Assembly | 118 |
| Nozzle Holder Assembly | 119 |
| Nozzle Pipe Assembly | 121 |
| Adjustment of 3-Way Valve | 123 |
| Safety Valve Activation | 123 |
| Readjustment of Boom - General Info | 123 |
| Alignment of Center Section and Inner Wing | 124 |
| Adjustment of Boom Tilt | 124 |
| Adjustment of Boom Wings (Boom Width: 120') | 125 |
| Adjustment of Breakaway Section | 132 |
| Yaw Damping | 133 |
| Wear Bushing Replacement on Boom Lift | 134 |
| Wear Bushing Replacement on Steering | 134 |
| Replacement of Transmission Shaft Shield | 134 |
| Replacement of Transmission Shaft Cross Journals | 134 |
| Change of Light Bulb | 134 |
| Change of Tire | 135 |
| Venting the Boom Hydraulics | 136 |
| TWIN System, Priming of Blower Transmission | 137 |
| Pressure Adjustment of Blower Transmission | 137 |

Table of Contents

| | |
|--|------------|
| Off-Season Storage | 138 |
| General Info | 138 |
| Before Storage | 138 |
| After Storage | 139 |
| 7 - Fault Finding | |
| Operational Problems | 141 |
| General Info | 141 |
| Liquid System | 142 |
| Hydraulic System, Z-version | 144 |
| TWIN System - Blower | 144 |
| Indication of Sensors for Boom Folding | 145 |
| Electric Fuses | 146 |
| Overview of Fuses | 147 |
| Mechanical Problems | 148 |
| Emergency Operation - Hydraulics | 148 |
| Emergency Operation - EasyClean Filter | 148 |
| Emergency Operation - Liquid System | 148 |
| 8 - Technical Specifications | |
| Dimensions | 149 |
| General Info | 149 |
| Overall Dimensions | 149 |
| Wheel and Axle Dimensions | 149 |
| Tire Pressure | 149 |
| Weight | 150 |
| Specifications | 151 |
| Diaphragm pumps | 151 |
| Tractor Requirements | 151 |
| Temperature and Pressure Ranges | 152 |
| Filters | 152 |
| Technical Residue | 152 |
| Blower For TWIN Air System | 153 |
| Airborne Noise Emission | 153 |
| Materials and Recycling | 154 |
| Disposal of the Sprayer | 154 |
| Disposal of Cleaning Water | 154 |
| Electrical Connections | 155 |
| Rear Lights | 155 |
| Boom and Work Lights | 156 |
| Hydraulic Diagrams | 157 |
| Chassis | 157 |
| TWIN System - Transmission | 158 |
| Spray Boom, 80' - 100' (24 - 30 m) | 158 |
| Spray Boom, 120' (36 m) | 159 |
| 9 - Warranty | |
| Warranty policy and conditions | 161 |
| Index | |
| Index | 163 |

Table of Contents

Welcome letter



Dear Owner,

Thank you for purchasing a HARDI® product and welcome to the ever-increasing family of HARDI® sprayer owners.

Our sprayers and accessories are rapidly becoming a familiar sight on North American farms. We believe that this results from growers becoming increasingly conscious of crop protection input costs and the vital need for cost effective spray application equipment.

Please take the time to thoroughly read the Operator's Manual before using your equipment. You will find many helpful hints as well as important safety and operation information.

Some of the features on your HARDI® sprayer were suggested by growers. There is no substitute for "on farm" experience and we invite your comments and suggestions. If any portion of this instruction book remains unclear after reading it, contact your HARDI® dealer or service personnel for further explanation before using the equipment.

For Product, Service or Warranty Information:

- Please contact your local HARDI® dealer.

To contact HARDI® directly:

- Please use the HARDI® Customer Service number: 1-866-770-7063

- Or send your email to CUSTSERV@hardi-us.com

Visit us online at: www.hardi-us.com

HARDI® NORTH AMERICA INC.

1500 West 76th St.
Davenport, Iowa 52806
Phone: (563) 386-1730
Fax: (563) 386-1280

Obligations and Liability

Comply with the Instruction Book

Knowledge of the basic safety information and safety regulations is a fundamental requirement for safe handling and fault-free sprayer operation.

Lack of knowledge or non-compliance of the safety instructions can lead to injuries and fatal accidents as well as damage to the sprayer and its surroundings.

Follow the safety instructions in this Instruction Book.



Before First Use of the Sprayer

The owner of the sprayer must take note of the following obligations before using the sprayer. These obligations also apply to the employer or the supervisor of the sprayer operators.

Worker / Operator Instructions

Only let people work with, or on the sprayer, who:

- Are aware of the basic workplace safety information and accident prevention regulations.
- Have been instructed in working with/on the tractor and sprayer, and have achieved appropriate qualifications.
- Have read and understood this Instruction Book.

A worker or operator is a person who installs, operates, configures, adjusts, maintains, cleans, repairs, transports or moves the sprayer.

If you still have questions after reading the Instruction Book, or if something remains unclear after reading it, please contact the manufacturer or your HARDI® dealer.

Inspection

Before first use of the sprayer, the owner must make a complete inspection of the sprayer and tractor to be used with the sprayer.

Restricted Use

As the use of the sprayer is likely to involve a specific risk, the owner shall ensure restricted access to its use as needed.

Restricted use also applies to the selection of tractor to be used together with the sprayer. It is the responsibility of the owner of the sprayer to make sure the tractor is adequate. This information must be available to the operator of the sprayer.

Maintenance Regulations

The owner shall ensure that the sprayer is installed and set up correctly and is operating properly by inspection/testing of the sprayer by authorized persons.

Health Issues

Ergonomics and occupational health aspects shall be taken fully into account by the owner.

2 - General Safety Instructions

Obligations of the Operator

Before starting work, the operator or anyone in charge of working with/on the sprayer must:

- Comply with the basic workplace safety instructions and accident prevention regulations.
- Read and follow the safety instructions as described in this Instruction Book.
- Read the section "Representation of Safety Symbols" on page 14 and to follow the safety instructions represented by the danger, warning and attention symbols, when operating the sprayer.
- Get to know the sprayer.
- Connect the sprayer securely and correctly to the tractor, which is approved for driving the sprayer.
- Read the sections of this Instruction Book that are important for carrying out the work.
- Read the manufacturer's information regarding safety and use of chemical products for crop care, such as spray chemicals or liquid fertilizer.
- Keep all the danger, warning and attention labels on the sprayer in a legible state.
- Replace damaged labels on the sprayer.
- Know the importance of the use of genuine HARDI® spare parts.

If the operator discovers that a function is not working properly, he must eliminate this fault immediately. If this is not the task of the operator, or if the operator does not possess the appropriate technical knowledge, then he should report this fault to his superior (a qualified operator).

Risks in Handling the Sprayer

The sprayer has been highly developed and constructed to the recognized rules of safety. However, operating the sprayer may cause risks to:

- The health and safety of the operator or others.
- Other property.

Only use the sprayer:

- For the purpose for which it was intended.
- In a fully functional state.

Eliminate any faults immediately which could impair the safety.

Disclaimer

Warranty and liability claims for damage to people or property will be excluded by HARDI® if they can be traced back to one or more of the following causes:

- Improper use of the sprayer.
- Improper installation, commissioning, operation or maintenance of the sprayer.
- Operation of the sprayer with defective safety equipment, or improperly attached or non-functioning safety equipment.
- Non-compliance with the instructions in the instruction manual regarding commissioning, operation and maintenance.
- Unauthorized design changes to the sprayer.
- Insufficient monitoring of sprayer parts which are subject to wear.
- Improperly executed repairs.
- Spare parts used are not genuine HARDI® spare parts. If the operator decides to use a spare part, which is not approved by HARDI®, the operator immediately assumes responsibility for any accident, damage or malfunction, which can be traced back to the use of this spare part. HARDI® accepts no liability for such incidents caused by the use of non-approved spare parts, wear parts or aids.
- Damage caused by uncontrollable events, such as natural disasters or unavoidable accidents.

Organizational Measures

This Instruction Book

- Must always be kept together with the sprayer.
- Must always be easily accessible for the operator.

Personal Protective Equipment

The operator must use the necessary personal protective equipment as per the information provided by the manufacturer of the plant protection product to be used, such as:



Chemical-resistant gloves



Chemical-resistant and disposable overalls



Water-resistant footwear



Face shield



Breathing protection



Eye protection



Head protection



Skin protection products

2 - General Safety Instructions

Representation of Safety Symbols

Explanation of Symbols

Safety symbols are used in the following chapters throughout this Instruction Book to designate where the reader needs to pay extra attention.

The signal word (DANGER, WARNING, ATTENTION or NOTE) describes the severity of the risk.

The symbols have the following meaning:



This symbol means DANGER. Be very alert as your safety is involved! The DANGER symbol indicates a high risk for immediate death or serious physical injury if the instruction is not followed.



This symbol means WARNING. Be alert as your safety can be involved! The WARNING symbol indicates a medium risk for serious injury or death if the instruction is not followed.



This symbol means ATTENTION. This indicates important information required for proper sprayer handling. This instruction will help you avoid problems with the sprayer or disturbance to the environment.



This symbol means NOTE. This indicates handling tips and particularly useful information. This instruction will help you to use all the functions of your sprayer in the best way possible for a better, easier and safer operation.

General Info



Note the following recommended precautions and safe operating practices before using the sprayer:

- Local law may demand that the operator is certified to use spray equipment. Adhere to the law.
- The driver's seat is the intended working place during operation.
- Wash and change clothes after spraying. Wash tools if they have become contaminated.
- Do not eat, drink or smoke while spraying or working with contaminated equipment. In case of poisoning, immediately seek medical advice. Remember to identify chemicals used.
- No persons are allowed in the operation area of the sprayer. Be careful not to hit people or surroundings when maneuvering the sprayer, especially while backing up.
- Slow down when driving in uneven terrain as the machine might be in risk of turning over.
- Keep children away from the equipment!
- Do not attempt to enter the tank.
- Do not go under any part of the sprayer unless it is secured. The boom is secure when placed in the transport brackets.
- Pressure test with clean water prior to filling with chemicals. Never disconnect the hoses if the machine is in operation.
- DANGER! Do not exceed the P.T.O. max. recommended rpm.
- Rinse and wash equipment after use and before servicing.
- Never service or repair the equipment while it is operating. Always replace all safety devices or shields immediately after servicing.
- Disconnect electrical power before servicing and depressurize equipment after use and before servicing.
- If an arc welder is used on the equipment or anything connected to the equipment, disconnect power leads before welding. Remove all inflammable or explosive material from the area.
- The External Cleaning Device should not be used if essential parts of the equipment have been damaged, including safety devices, high pressure hoses, etc.

2 - General Safety Instructions

Warning Labels On The Sprayer

Explanation of Labels

The labels on the sprayer designate potential dangerous areas on the machine. Operators, or anyone in close range of the sprayer must respect these warnings!

The labels should always be clean and readable! Worn or damaged labels must be replaced with new ones. Contact your HARDI® dealer for new labels.



978434 - Risk of squeezing!

Keep hands away, when parts is moving.



978436 - Service!

Turn off the engine and remove ignition key before performing maintenance or repair.



978439 - Lifting point!



978440 - Bolt torque

Tighten to torque settings according to operator's manual.



978441 - Risk of squeezing!

Stay clear of raised and unsecured loads.



978442 - Risk of falling off!

Do not attempt to enter tank.



978444 - Risk of injury!

Do not open or remove safety shields while engine is running.



978447 - Risk of burn!

Stay clear of hot surfaces.



97802100 - Risk of death!

Do not attempt to enter tank.



97802200 - Not for drinking!

This water must never be used for drinking.



97814500 - Hydraulic Lock Valve!

Always lock valve when leaving the sprayer standing on hydraulic support leg.



97827000 - EasyClean filter

Open and clean filter monthly.



97842200 - Not for drinking!

This water must never be used for drinking.



10532403 - Rotating PTO

Rotating driveline contact can cause death. Keep away!



10532503 - Hydraulic hazard

Risk of serious injury or death from escaping hydraulic fluid.



10532603 - Not for drinking

This water must never be used for drinking.

2 - General Safety Instructions



10532703 - Crush fingers
Never place fingers in clutch.



10532803 - Fold wings
Keep away when folding, unfolding wings.



10532903 - Tank drain
Tank contents will drain when handle is pulled.



10533003 - Overhead lines
Do not contact electrical lines when moving or operating!



10533103 - General label
Read Operator's manual and chemical manufacturer's instructions.



10533203 - Chemicals
Carefully read information about chemicals before handling. Observe all safety rules.



10533303 - Quick fill
Keep valve closed and capped.



10533403 - Axle adjust
Risk of serious injury or death from crushing. Securely support sprayer.



10533503 - Crush hazard
Risk of serious injury or death from crushing.



10533603 - Open slowly
Contents under pressure. Open cap slowly.



10533803 - Red Reflector



10533903 - Amber Reflector



10577603 - Do not weld
Disconnect all electronics before welding. Avoid high pressure spray on components.



10601403 - SMV Sign
Slow Moving Vehicle.



10616103 - Paralift™
Risk of serious injury or death from crushing. Do not enter between tank and center frame.



97606603 - Pre-Delivery
Remove tie straps before unfolding boom first time.



97610103 - Tank return hose
Tank return hose must be connected to a low pressure return port.

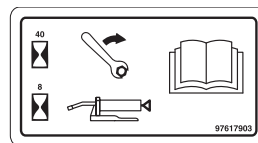

97617903 - Breakaway
See Boom Operator's manual for maintenance.

Safety and Protection Equipment

Safety at Start up

Each time before the sprayer is started up, all the safety and protection equipment must be properly attached and fully functional.

Check the sprayer at least once a day under normal operation for visible damage. Check the function of the safety and protection equipment.

Repair or replace the equipment as needed.

Only operate the sprayer if all the safety and protection equipment is fully functional.

Faulty Safety Equipment

Faulty or disassembled safety and protection equipment can lead to dangerous situations.

Additional Safety Instructions

Together with the safety information in this Instruction Book, also comply with the general and local regulations related to:

- Accident prevention.
- Environmental protection.
- The applicable workplace safety.

Follow these regulations, especially when:

- Driving on public roads and routes. Comply with the appropriate statutory road traffic regulations. These vary from state to state, and there may be local regulations which need to be followed.
- Local law demands that the operator is certified to use spray equipment.
- Using pesticides or liquid fertilizer. Make sure you understand the information from the supplier regarding their use.



Never service or repair the equipment while it is operating. Always replace all safety devices or shields immediately after servicing.



Disconnect electrical power before servicing and depressurize equipment after use and before servicing.



If an arc welder is used on the equipment or anything connected to the equipment, disconnect power leads before welding. Remove all inflammable or explosive material from the area.



The External Cleaning Device should not be used if essential parts of the equipment have been damaged, including safety devices, high pressure hoses, etc.

2 - General Safety Instructions

Local poison information center



If you live anywhere in the United States, the following toll free number will connect you to your Local Poison Information Center.

PHONE NO. 1 - 800 - 222 - 1222



If you live outside the United States, find the number for the poison control center in your phone book and write it in the space below:

PHONE NO. _____ - _____ - _____



Keep a list, in the space provided below, of all the chemicals that you have in use.

1. _____

2. _____

3. _____

4. _____

5. _____

6. _____

7. _____

8. _____

9. _____

10. _____

General Info

View

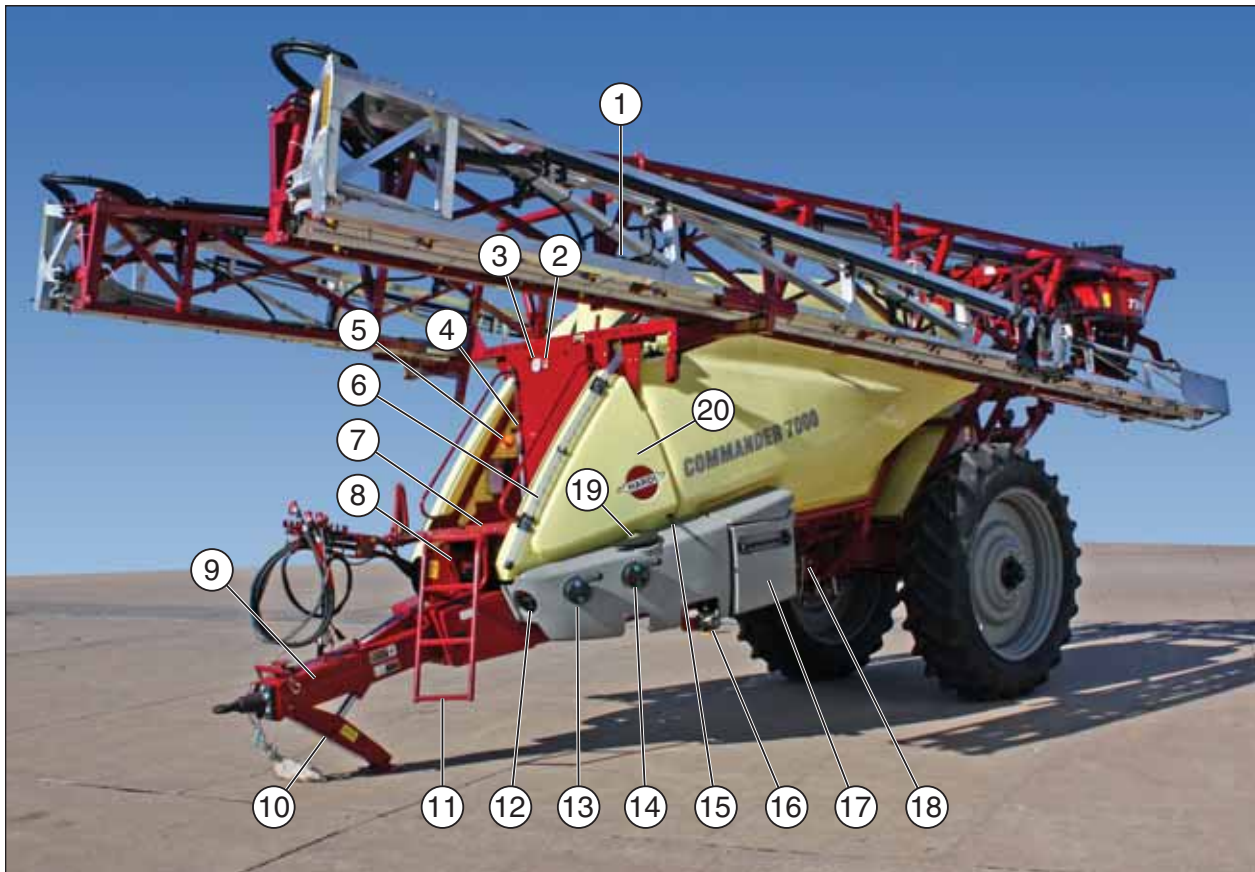

- | | |
|---------------------------------|-------------------------------------|
| 1. Main Tank Lid | 11. Ladder |
| 2. EasyClean clogging indicator | 12. Agitation valve |
| 3. Spray pressure gauge | 13. Suction SmartValve |
| 4. Rinsing tank level indicator | 14. Pressure SmartValve |
| 5. Clean water tank lid | 15. Clean water valve |
| 6. Main tank level indicator | 16. Rinsing tank Quick Fill coupler |
| 7. Platform | 17. TurboFiller |
| 8. Pump | 18. Main tank Quick Fill coupler |
| 9. Drawbar | 19. EasyClean filter |
| 10. Support leg | 20. SafetyLocker |

3 - Description

View



21. Distribution Valves

22. Blower for TWIN Air System

23. Spray Boom

24. Rinsing Tank

25. Main Tank

26. Clean Water Tank

27. Canister for Chemical Information

28. ChemLocker / Spray Wand for External Cleaning

29. Hose Reel for Spray Wand

30. CycloneFilter

3 - Description

Identification Plates

An identification plate indicating producer name and reference number is mounted on the frame near the front of the sprayer on the right-hand side. The first 4 digits of the reference number indicate the market and year of production.

03 - North America
YY - Year of production.



An identification plate indicating data for the sprayer is mounted on the frame near the front of the sprayer on the right-hand side.

The identification number for the sprayer is also punched into the steel frame near the ID plate.

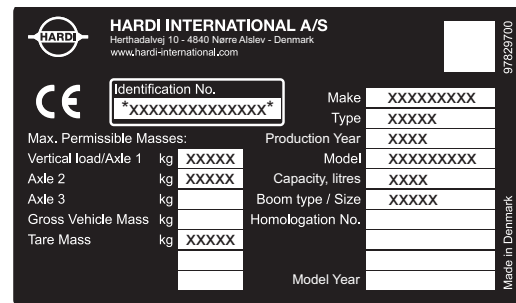

Data

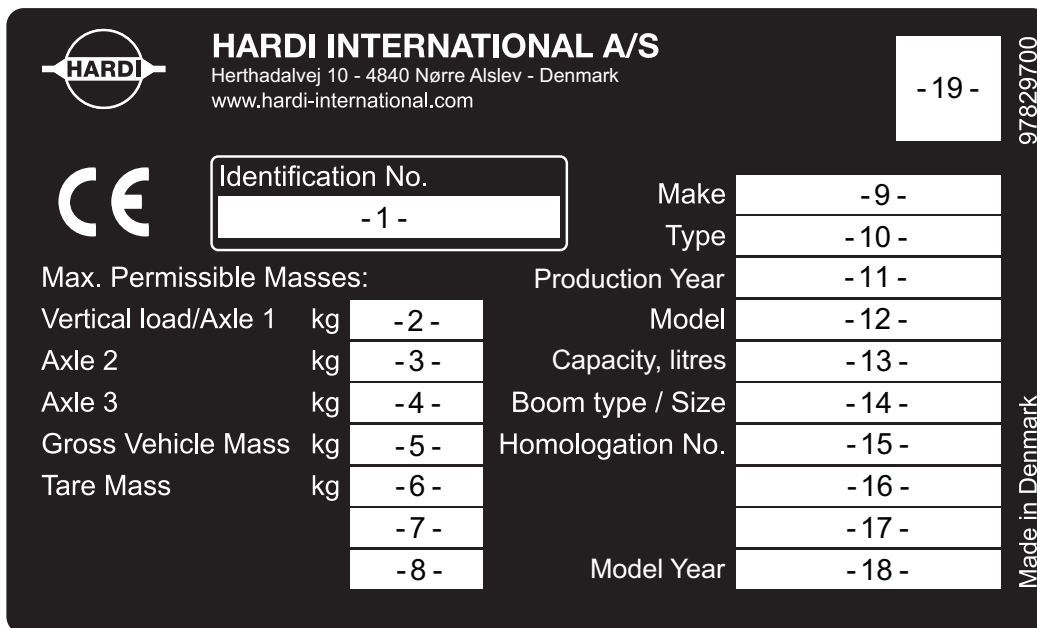

The following page explains the data on the international ID plate.

3 - Description

| No. | Field name | Description |
|------|--|--|
| -1- | Identification No. | Coded number identifying the machine. Includes manufacturer, production year, type and ends with a continuous serial number. The identification number uniquely identifies one specific sprayer for the model. |
| -2- | Vertical load/Axle 1 | The vertical load from the trailer drawbar applied to the tractor's towing bar or hitch (for trailers). Axle load, front axle (self-propelled units). Determined by design, dimensioning and/or type approvals. In type approval context, the trailer drawbar is considered to be an "axle", so the drawbar will be Axle 1, and the first "real" axle will be Axle 2. Axle number is counted from front to rear. |
| -3- | Axle 2 | Axle load on first axle after the towing eye (for trailers) counted from front towards rear OR second axle (at rear) for a self-propelled unit with 2 axles. |
| -4- | Axle 3 | Axle load on second axle after the towing hitch, counted from front to rear. The rear of a boogie on a trailer or the rear axle on a self-propelled unit with 3 axles. |
| -5- | Gross vehicle mass | Same as laden weight or gross weight. Definition: Weight of a vehicle, fully equipped and serviced, including the weight of the fuel, lubricants, coolant, vehicle tools and spares, crew, personal equipment, and load. Determined by design, dimensioning and/or homologation. |
| -6- | Tare mass | Same as unladen weight. Vehicle net weight without load, but with fuel, driver etc. Typically the heaviest configuration is stated for all variants (most vehicles are lighter than the stated tare mass). |
| -7- | Not used. In special cases: GCWR / PTRA | Reserved for future use. Sum of gross vehicle masses of towing vehicle and trailer. USA: Gross Combination Weight Rating (GCWR). France: Poids Total Roulant Autorisé (PTRA). Reserved for future use. |
| -8- | Not used. In special cases: Drawbar category | Minimum required drawbar category to tow the trailer. Horsepower (HP) dependent. CAT I: 20 -45 HP CAT II: 40-100 HP CAT III: 80-275 HP CAT IV: 180-400 HP |
| -9- | Make | Manufacturer or brand name. The HARDI® group currently has two makes: HARDI® and EVRARD. |
| -10- | Type | Defined type – related to type approvals definition: A grouping based on shared characteristics. E.g. lift sprayer, trailer sprayer, mist blower, field sprayer, self-propelled sprayer etc. In homologation and type approval context, the "Type" refers to the particular form and shape of a chassis (i.e. the chassis drawing number). Can be stated encoded. |
| -11- | Production Year | Year of production start. In all factories and markets in the EU, the production year is stated in clear text separately. In other regions, "5211" means "produced in week 52 of the year 2011" etc. |
| -12- | Model | A particular design within a sprayer type. E.g. type of sprayer models are NK, MASTER, METEOR etc. |
| -13- | Capacity | Rated or nominal content of the main tank. (The tank is oversized to retain overfilling, foam etc.) |
| -14- | Boom type/size | The 2- or 3-character boom type abbreviation / boom width in meters or feet. |
| -15- | Homologation No. | Reference to the homologation or approval document as issued by the approving authority (e.g. KBA, DREAL etc.). In France, this field contains the approval date. |
| -16- | Homologation (II) | The town of the authority office, who issued the type approval. |
| -17- | Not used. | Reserved for future use. |
| -18- | Model Year | Year of shipment from factory. |
| -19- | Not used. | Reserved for future use. |

Sprayer Use

The HARDI® sprayer is for the application of crop protection chemicals and liquid fertilizers. The equipment must only be used for this purpose. It is not allowed to use the sprayer for any other purposes.

If no local law demands that the operator must be certified to use spray equipment, it is strongly recommended to be trained in correct plant protection and in safe handling of plant protection chemicals to prevent unnecessary risk for persons and the environment, when carrying out your spray job.

Steel Frame

Very strong and compact steel frame with a strong chemically resistant and weatherproof electrostatic lacquer coat. Screws and bolts etc. are made of stainless steel, or they have been Delta/Magni-treated to resist corrosion.

Tanks

The tanks are made of impact-proof polyethylene, resistant to UV radiation and chemicals.

The main tank has a purposeful design with no sharp corners for easy cleaning.

The filling hole is placed so it can be accessed from the platform. This ensures an easy access for the filling and cleaning of the tank, etc. The sprayer may also be equipped with a TurboFiller, rinsing tank and a clean water tank. A large, easy-to-read tank level indicator is placed beside the platform, where it is visible from the tractor cabin and in the work zone of the sprayer.

Nominal main tank contents are 1200 gal. (4500 liters), 1600 gal. (5500 liters) 2000 gal. (7000 liters).

Lifetime

The expected lifetime for the sprayer is 20 years.

To obtain this successfully, these instructions should be followed:

- All service and maintenance work must be completed in due time
- Repair any damaged parts as quickly as possible
- Replace or change spare parts as instructed
- Only use original HARDI® spare parts.



3 - Description

Liquid System

Pump

Diaphragm pump with 6 diaphragms, model 464.

1000 rpm (20/21-spline shaft).

The design of the diaphragm pump is simple, with accessible diaphragms and valves, which ensures that liquid does not contact the vital parts of the pump.



FlexCapacity Pump

Some sprayers include a dual pump setup with an extra hydraulically driven pump of the same type as the main pump. It is placed on the sprayer's right side.

The FlexCapacity pump is turned on/off with a separate hydraulic lever in the tractor cabin.



Valves and Symbols

The possible functions of valves are distinguished by colored identification on the function labels. The modular valve system facilitates the addition of optional extras on both pressure side and suction side. A function is activated by turning the handle to the desired function.



ATTENTION! Only the functions used should be open - always close remaining valves.



ATTENTION! If a valve is too tight to operate - or too loose (= liquid leakage), the valve needs to be serviced. Please see "Adjustment of 3-Way Valve" on page 123 for further information.

Pressure SmartValve (Green Symbols)

This valve is to select which function the pressurized liquid from the pump will be routed to.

The active function is indicated by the little steel knob above the handle. The handle is turned so the desired symbol is just below the steel knob. If the handle is turned to a position without a symbol (unused function), then the valve is closed.

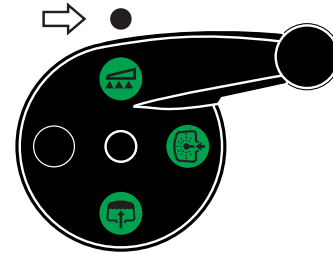

Suction SmartValve (Blue Symbols)

This valve is to select suction from main tank or from the rinsing tank.

The handle is turned so the desired symbol is just below the steel knob. If the handle is turned to vertical position (no symbol below steel knob), then the valve is closed.

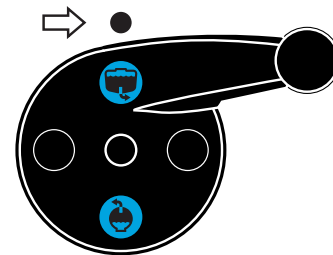

Agitation Valve (Green Symbol)

With the adjustable agitation valve it is possible to combine spraying with a high volume rate at high pressure with agitation at the same time.

This is regulated by the valve: The valve is marked with an arrow on the disc which indicates the amount of liquid that passes through the valve.

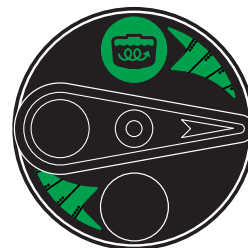

Choose your own valve setting, depending on the tank contents:

- The handle is turned to a position near the tip of the arrow: Only a small amount of liquid is allowed to pass the valve resulting in less vigorous agitation. This is recommended when using chemicals with a low density to prevent foaming in the tank.
- The handle is turned to a position in the wide end of the arrow: A large amount of liquid will pass the valve resulting in a more vigorous agitation. This is recommended when using chemicals with a high density, which will tend to settle at the bottom of the tank.

3 - Description

DynamicFluid4 Pressure Regulation

DynamicFluid4 regulation is a continuous process that continues even if the nozzles are closed. Two ceramic discs regulate the pressure and ensures quick reaction and zero leakages. Sprayer speed, P.T.O. rpm and number of sections activated are parameters used, and the benefit is more precise application rates from the second the sprayer begins spraying.

The DynamicFluid4 uses feed forward technology based on 5 sensors that feed the JobCom computer with data necessary for optimal regulation. It auto-primes at start-up, starts and moves the valve towards the final position immediately after the operator makes changes. E.g. when section valves are opened or closed, the regulation valve is started the same time the section valve motors are started. This avoids overpressure situations e.g. after running empty and refill of main tank.

The 5 sensors are also back-up for each other and ensures the system can continue regulation even if one or more sensor signals fail. Sensors used are:









- Sprayer speed sensor
- Flow sensor
- Pressure sensor
- Pump rpm sensor
- Regulation valve opening angle sensor

The DynamicFluid4 pressure regulation features are:

- Very fast and accurate regulation when all sensors are ok, setup in menus are correct and pump, filters and valves are in good condition.
- Quick reacting valve when sections are turned ON/OFF and at speed changes.
- Optimized AutoSectionControl feature that predicts boom sections will open and nozzle pressure.
- Optimized for different P.T.O. systems.
- Nozzle surveillance. No setup or tuning required for nozzle change.
- Warning in display if failures occur on boom plumbing, such as severe clogging of line or nozzle filters or large leakages on hoses and fittings.
- All functions work, although with degraded performance (Limp home modes), if:
 - Faults occur in fluid system, e.g. pump defects, clogged filters, leaking valves.
 - Sensor failure appear on pressure sensor, flow sensor or RPM sensor.
 - There is wrong setup of sprayer data in menus.
- Emergency mode if angle sensor or speed sensor fails.

Screen Icons

The sprayer driver selects one of three modes Auto, Manual or Increment steps. The sprayer computer detects one of three regulation modes Drop, Question mark or calibration jug. This makes 9 modes in total.

| Auto | Manual | Increment steps | |
|---|---|---|---|
| When Automatic Volume Rate button is pressed on the SetBox. | When one of the Manual pressure control buttons is pressed on the SetBox. | When the Volume Rate is changed in steps with %-up or %-down buttons on the Terminal. | |
|  |  |  | Calibration jug There is flow to section valves. Nozzle size (G/min at 45 psi) has been calculated. |
|  |  |  | Drop There is no flow to section valves. The pump is not started or the pressure SmartValve is set to other function than spraying. |
|  |  |  | Question mark There is flow to section valves but pressure and flow has not yet been stable, therefore the nozzle size (G/min at 45 psi) has not been calculated. The system uses the previously stored nozzle size. |

3 - Description

Regulation Valve Function Diagram



ATTENTION! Auto mode icons shown, but could be Manual or Increment steps icons, depending on driver selection.

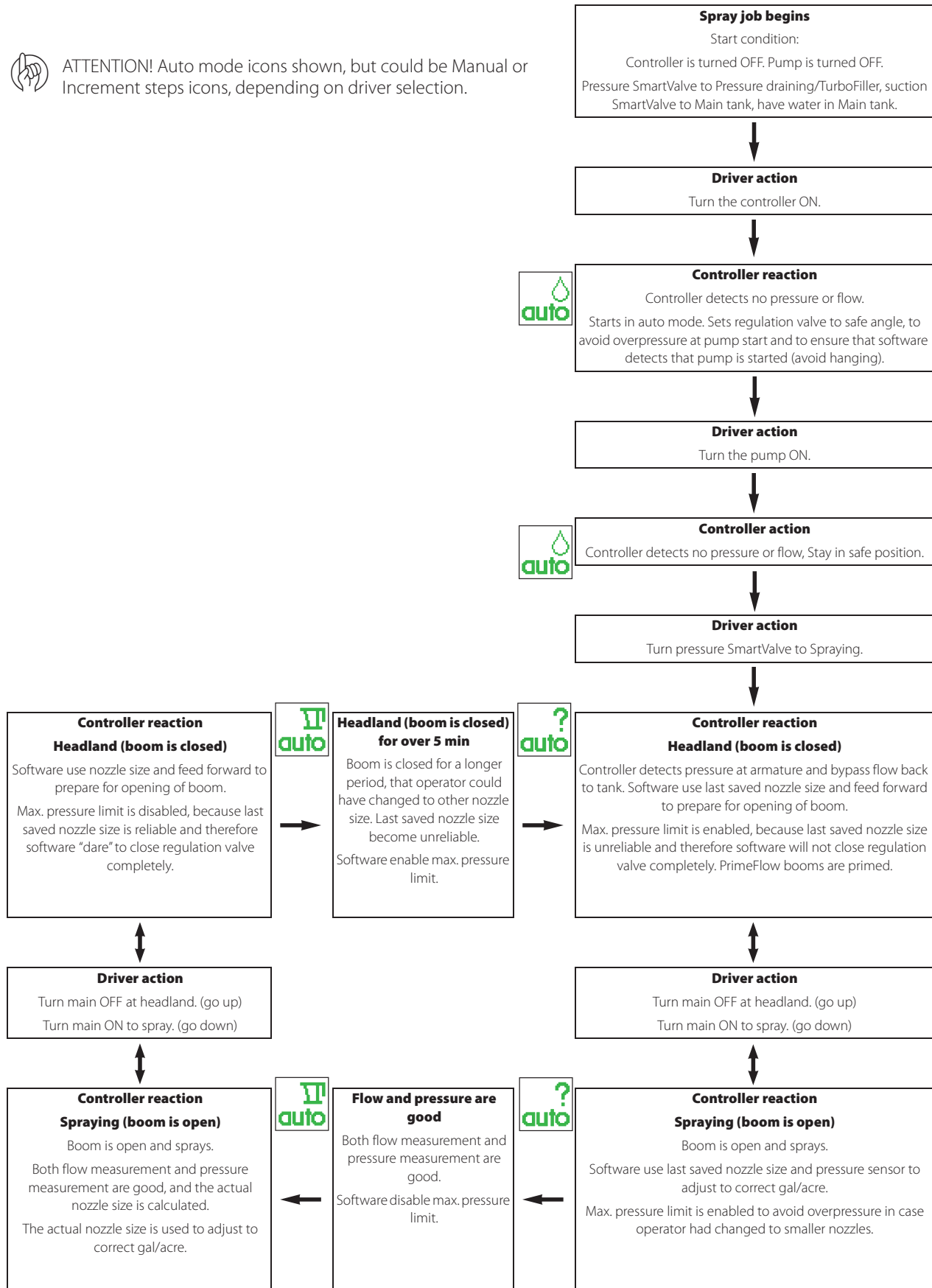

3 - Description

Filters

Filters on your sprayer are there to protect the components and prevent nozzle clogging.

An EasyClean suction filter is fitted in the working zone.

A Cyclone pressure filter is fitted on the sprayer's right side just in front of the hose reel, hidden behind the right front cover. It has a built-in self-cleaning function.

In-line pressure filters can be fitted at each boom section.

Nozzle filters are fitted at each nozzle (optional).

A coarse filter basket is located below the main tank lid.



ATTENTION! All filters should always be in use and their function should be checked regularly. Pay attention to the correct combination of filter and mesh size. For more, see "Filters" on page 152.



ATTENTION! Always run your sprayer with clean filters to ensure proper functions and to protect the interior of the pump and valves.

EasyClean Filter

This filter collects impurities when liquid is being sucked out of the main tank by the main pump.

To ensure proper function of the filter and its built-in valve, the filter must be opened at least once every month. A label on the lid also designates this.



A clogging indicator is located beside the spray pressure gauge on the platform. This works as a vacuum gauge for the filter during operation - the pointer moves from green towards red, if the filter starts clogging.

| Clogging indicator | Filter condition |
|--------------------|---|
| Green area | 70 - 100 % capacity. No cleaning necessary. |
| Yellow area | 55 - 70 % capacity It is possible to finish an ongoing spray job and then clean the filter afterwards. |
| Red area | 0 - 55 % capacity Clean the filter immediately, as it is clogged too much for proper function. |



CycloneFilter

With the CycloneFilter, any impurities in the spray liquid will be cleaned out and returned to the main tank via the return flow.

Function diagram:

1. Filter lid
2. Intake from pump
3. Output to boom
4. Return to tank
5. Return valve

The return valve (5) has three positions marked with small dots on the lever:

- A. This position is marked with 1 dot:

There is no return flow. This position is used when rinsing the boom if there is spray liquid in the main tank. Also used when high spraying volume is required.

- B. This position is marked with 2 dots:

Normal position when spraying. With return flow to prevent filter from clogging during spraying. This position is used when rinsing the boom, if the main tank is empty.

- C. This position is marked with 3 dots:

Flushing position which is used if the filter is clogged. Lift and hold the lever to use this position, which largely increases return flow and flushes the filter. The pressure SmartValve must be set for "Spraying".



ATTENTION! Use of position C is no guarantee for a clean filter. Always perform regular inspections and cleaning of the filter. For more about cleaning, see the section "10 Hours Service - CycloneFilter" on page 105.



DANGER! Never open the CycloneFilter unless the pressure SmartValve is closed (turned to unused position). Otherwise, spraying liquid may hit you when opening the filter, and also drain from the main tank!

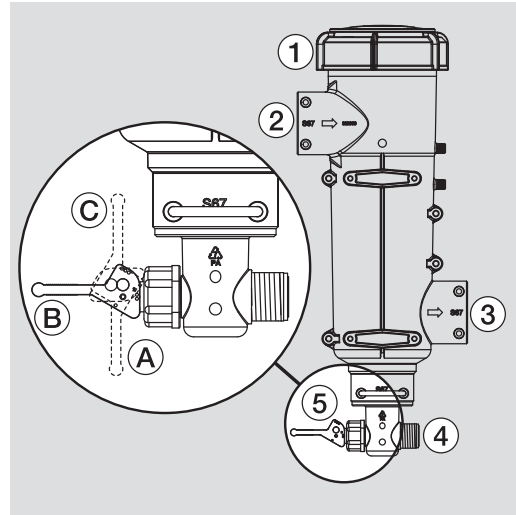

3 - Description

TurboFiller

The TurboFiller is used to add chemicals to be mixed with water in the main tank.

Capacity: approximately 9.25 gal. (35 liters).

Before Use

- Push the lever (arrow) to unlock.
- Grab the handle to pull the TurboFiller down until it clicks into locked position.

After Use

- Push the lever (arrow) to unlock.
- Lift the TurboFiller back in storage position until it locks.



WARNING! Before releasing the lock, always keep a hand on the grip to avoid abrupt movement of the TurboFiller!



TurboFiller Suction Valve

The valve is used simultaneously with the TurboFiller. The valve has 2 settings: Continuously open or spring-loaded normally closed.

Open the valve by lifting the lever up when chemicals are to be filled into the TurboFiller and transferred to main tank.

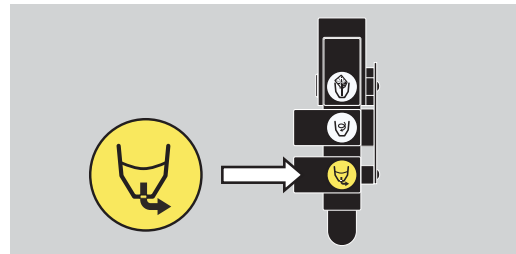

TurboDeflector Valve

This TurboDeflector valve activates the vortex flushing of the TurboFiller. Lift the lever to lock it in open position for continuous liquid rotation in the hopper.

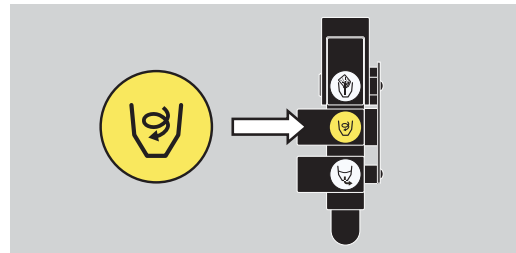

Chemical Container Rinsing Lever

The upper lever is used for two purposes.

1. When the TurboFiller lid is open:
For rinsing empty containers. Place the container over the rotating flushing nozzle in the middle of the TurboFiller to rinse the inside of the container.
2. When the TurboFiller lid is closed:
Use the lever to rinse the hopper after the filling of chemicals is completed.

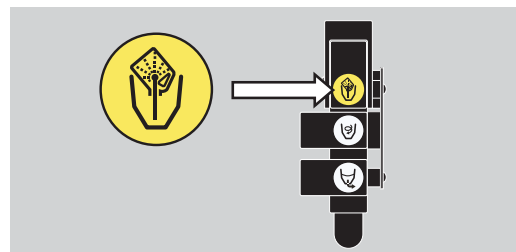

DANGER! Do not activate this lever unless the multi-hole nozzle is covered by a container, or the TurboFiller lid is closed, to avoid spray liquid hitting the operator! Risk of injuries and spillage on the ground.

Rinsing Tank

One rinsing tank is mounted at the rear of the sprayer behind the main tank. The tank is made of impact-proof and chemical resistant polyethylene. It is used for rinsing and flushing of the main tank and liquid system.

Capacity: approximately 130 gal. (500 liters).



Clean Water Tank

A clean water tank is integrated into the right side cover. It is accessed for filling at the sprayer's right side when entering the platform. The ball valve (A) for water draining is located behind the gray side cover on the sprayer's left side.

The water in this tank is for hand washing, cleaning of clogged nozzles etc. Only fill this tank with clean water.

Capacity: approximately 5 gal. (20 liters).



WARNING! Although the clean water tank is only filled with clean water, this water must NOT be used for drinking.



3 - Description

Diagram - Basic Liquid System

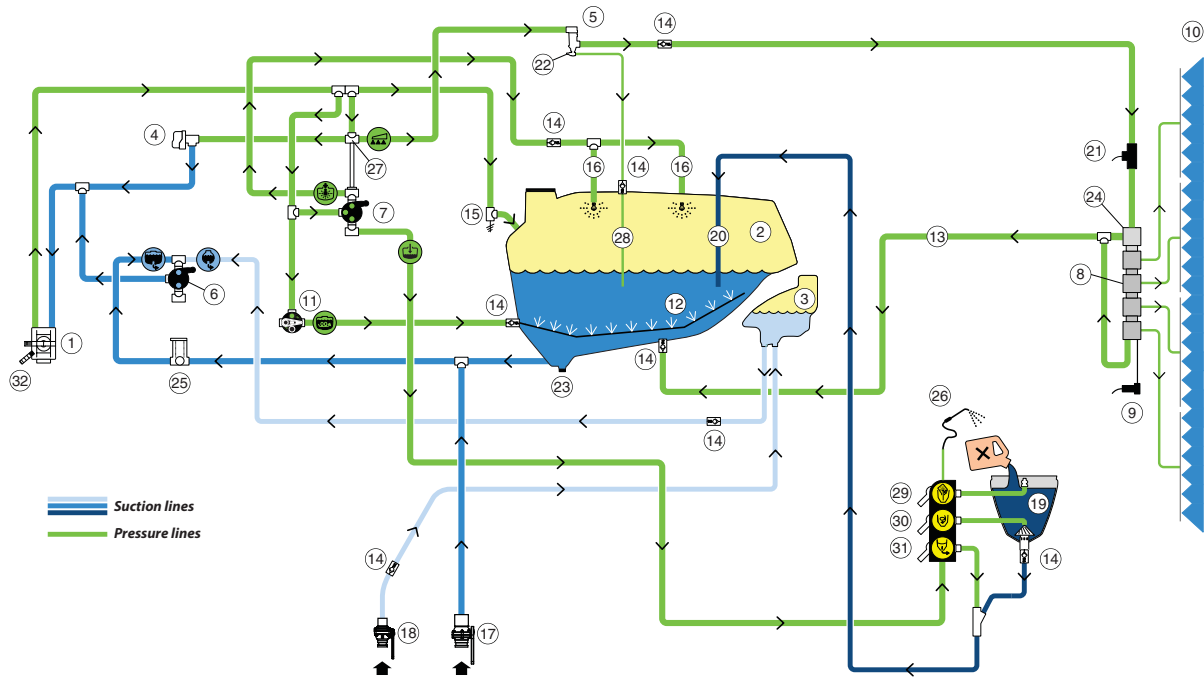

- | | |
|--|---------------------------------------|
| 1. Main Pump | 17. Main Tank Quick Fill Coupler |
| 2. Main Tank | 18. Rinsing Tank Quick Fill Coupler |
| 3. Rinsing Tank | 19. TurboFiller |
| 4. DynamicFluid4 Pressure Regulation Valve | 20. TurboFiller to tank tube |
| 5. CycloneFilter | 21. Flow Meter |
| 6. Suction SmartValve | 22. Boost Valve |
| 7. Pressure SmartValve | 23. Drain Valve |
| 8. Distribution Valves | 24. Bypass Valve |
| 9. Boom Pressure Sensor | 25. EasyClean Filter |
| 10. Sprayer Boom | 26. TurboFiller Cleaning Wand |
| 11. Agitation Valve | 27. Spray Valve |
| 12. Agitation Tube | 28. Return Line for Boost Function |
| 13. Return from Distribution Valves | 29. Chemical Container Cleaning Valve |
| 14. One-Way Valve | 30. TurboFiller Deflector Valve |
| 15. Safety Valve | 31. TurboFiller Suction Valve |
| 16. Internal Tank Rinsing Nozzles | 32. Speed Sensor for Main Pump |

Diagram - Liquid System with Optional Extras

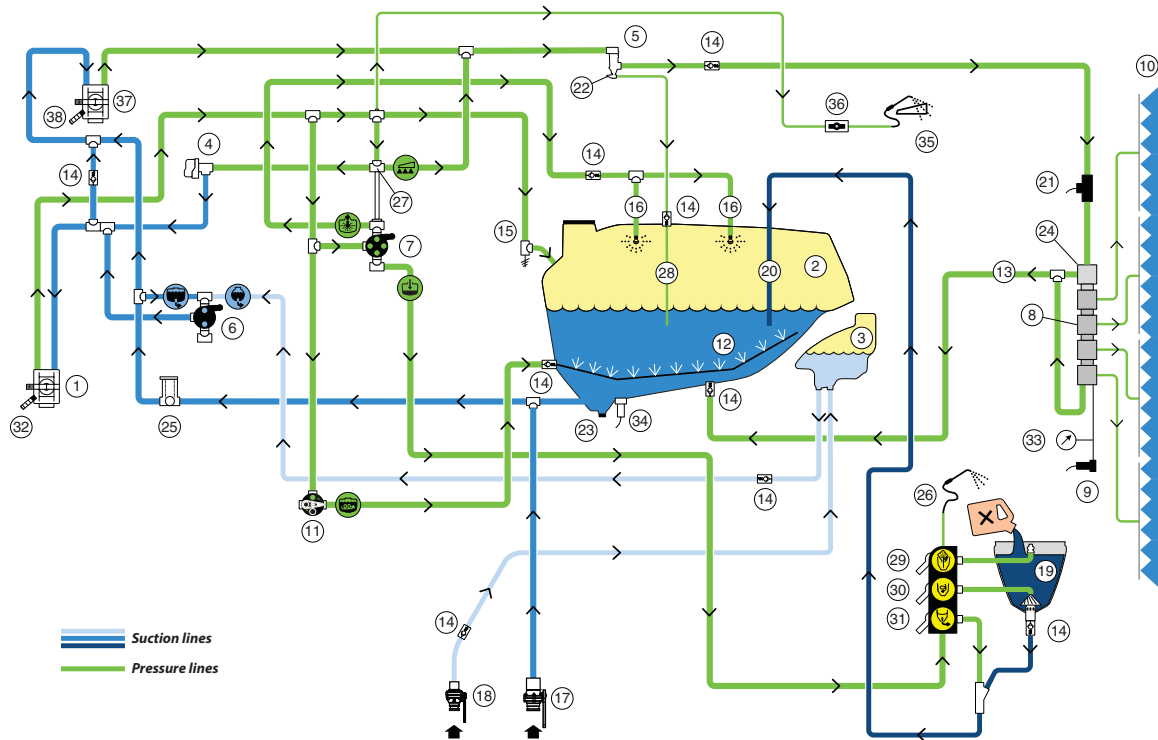

- | | |
|--|---------------------------------------|
| 1. Main Pump | 21. Flow Meter |
| 2. Main Tank | 22. Boost Valve |
| 3. Rinsing Tank | 23. Drain Valve |
| 4. DynamicFluid4 Pressure Regulation Valve | 24. Bypass Valve |
| 5. CycloneFilter | 25. EasyClean Filter |
| 6. Suction SmartValve | 26. TurboFiller Cleaning Wand |
| 7. Pressure SmartValve | 27. Spray Valve |
| 8. Distribution Valves | 28. Return Line for Boost Function |
| 9. Boom Pressure Sensor | 29. Chemical Container Cleaning Valve |
| 10. Sprayer Boom | 30. TurboFiller Deflector Valve |
| 11. Agitation Valve | 31. TurboFiller Suction Valve |
| 12. Agitation Tube | 32. Speed Sensor for Main Pump |
| 13. Return from Distribution Valves | |
| 14. One-Way Valve | |
| 15. Safety Valve | |
| 16. Internal Tank Rinsing Nozzles | |
| 17. Main Tank Quick Fill Coupler | |
| 18. Rinsing Tank Quick Fill Coupler | |
| 19. TurboFiller | |
| 20. TurboFiller to tank tube | |

Options

- 33. Boom Pressure Gauge
- 34. Main Tank Gauge
- 35. External Cleaning Device
- 36. External Cleaning Device Valve
- 37. FlexCapacity Pump
- 38. Speed Sensor for FlexCapacity Pump

3 - Description

TWIN Air System

General Info

With TWIN air assistance, energy is added to the spray droplets to improve control of the spray liquid.

The main purpose of the TWIN air system is to counteract for the negative influence that wind direction and driving speed have on the quality of the spray job.

Technique

- A. Air bag with compressed air from a blower. The air stream is led out of the air bag near the spray nozzles through an air channel.
- B. Angle of air stream.
- C. Angle of spray liquid.

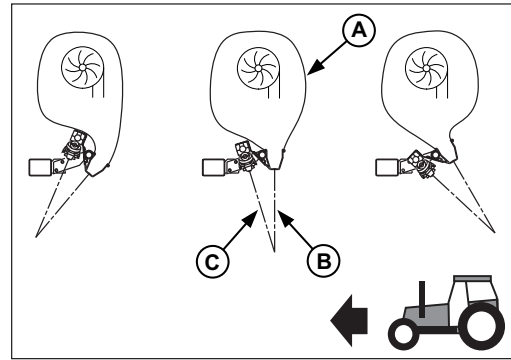

By using the air assistance while spraying and by varying the angle of air depending on wind and driving speed, the TWIN air system makes it possible to:

- bring the spray droplets safely to the target and increase the plant deposit.
- minimize off-target deposit due to wind drift or loss on the ground.
- open the crop and obtain good penetration, even with a low application rate.
- ensure a high crop coverage.

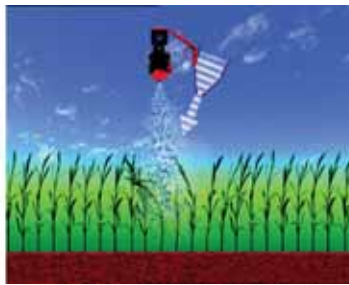
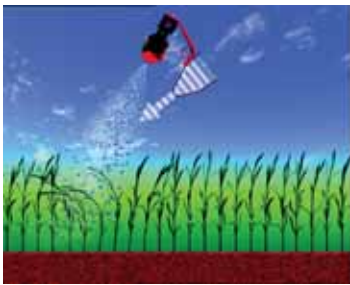

Hydraulic System

Hydraulic Blocks

Hydraulic blocks installed on the sprayer are described below.

Spray Boom

The main hydraulic block which manages hydraulic pressure for the boom controls.

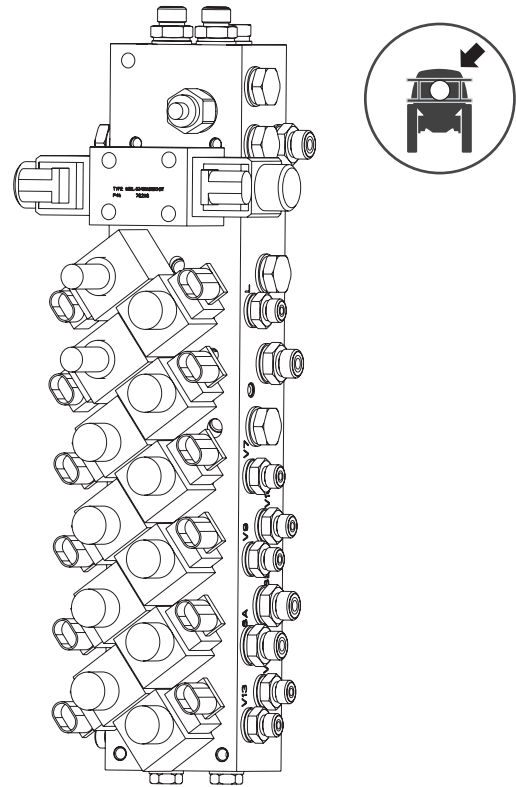

ParaLift

This hydraulic block manages hydraulic pressure for the ParaLift when raising or lowering the spray boom.



3 - Description

Open Center Hydraulics

The open center hydraulics block is necessary if the tractor uses open center hydraulics and/or load sensing.

For adjustment, see “Open and Closed Center Hydraulics” on page 53.

If in doubt whether your tractor uses open or closed center hydraulics, see the tractor’s instruction book or ask your tractor dealer.



SafeTrack

On sprayers with SafeTrack steering, this hydraulic block manages hydraulic pressure for the steering functions.

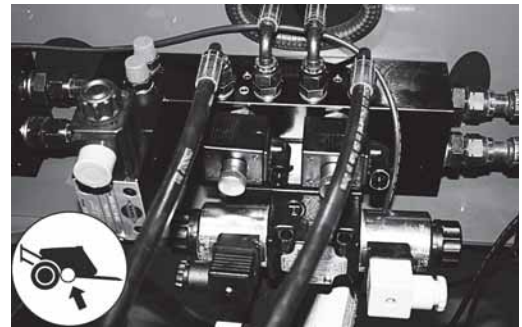

AutoHeight and AutoTerrain

This hydraulic block manages hydraulic pressure for the automatic control functions for boom height during spraying.

The three valves marked with arrows:

- The AutoHeight function has two valves.
- The AutoTerrain function has three valves.

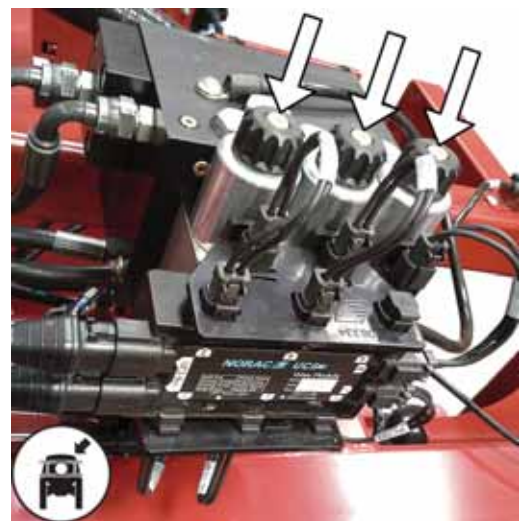

Spray Boom

Spray Boom and Terminology

The TWIN FORCE boom (HAZ) is trapeze suspended.

The boom is operated in a strong and stable parallelogram-shaped boom lift (ParaLift).

The boom is fully hydraulic operated with all functions controlled via the direct hydraulic system (DH).

The boom is available in 80', 90', 100' or 120' working widths.

Standard Boom Features

- Individual tilt of boom wings.



- Negative tilt below horizontal.



- Each boom has bi-fold wings.



- Alternative boom width:
The boom may be used in 1/2-folded boom width.



- Spring-loaded breakaway section.



- Air blowers for TWIN Air system.
These are driven by a built-in hydrostatic transmission powered by the tractor's PTO.
The air speed can be adjusted from the tractor cabin.



3 - Description

Available Working Widths

| Full working width (meters) | 1/2-folded width (meters) |
|--------------------------------|------------------------------|
| 80' (24 m) | 40' (12 m) |
| 90' (28 m) | 50' (15 m) |
| 100' (30 m) | 50' (15 m) |
| 120' (36 m) | 50' (15 m) |

Terminology

For this bi-fold boom, the terminology is as follows:

- A. Center section
- B. Inner wing
- C. Outer wing
- D. Breakaway section

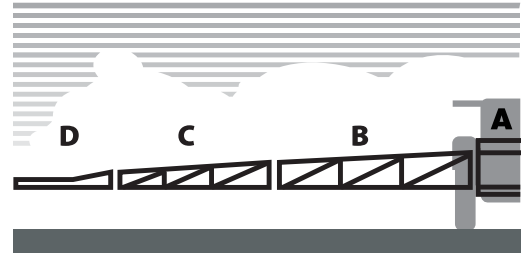

Other Equipment

Control Units in the Tractor

The sprayer is operated using these control units, which are delivered with the sprayer.

The control units are to be installed in the tractor, before using the sprayer.



i NOTE! The control units might look different depending on your delivery.

| | |
|---------------|--|
| 1. Controller | All main spray functions, settings and readouts are selected on this screen. |
| 2. Grip | The functions most frequently used while spraying can be operated here. |
| 3. SetBox | Secondary functions can be operated here. |

The Grip and SetBox are prepared for ISOBUS connections.

For instructions on how to operate the Controller, see the Controller's instruction book delivered with the sprayer.

For instructions on how to operate the Grip and SetBox, see "Operating the Grip" on page 70 and "Operating the Control Unit While Spraying" on page 72.

3 - Description

Platform

To get access to the platform, pull and tilt the ladder down. In retracted position, the ladder is secured by a rubber stop.

From the platform you can access:

- Lid for main tank at the top of the sprayer.
- On the left side of the platform (as shown in the picture):
 - Integrated clean water tank.
 - Flexible tube showing the water level in the rinsing tank.
- Above the platform:
 - Pressure gauge and EasyClean filter clogging indicator.
- Lift and remove the platform floor (A) for access to hydraulic and manifold components.
- Remove the cover plate (B) to access electronics.



ATTENTION! Always tilt the ladder up before moving the sprayer.



Nozzle Pressure Gauge

The remote pressure gauge is integrated at the top of the platform. This pressure gauge measures the working pressure in the boom pipes as close to the nozzles as possible.

The outputs stated in the nozzle charts are always based on the pressure measured at the nozzle. Both when calibrating and spraying, the pressure must be adjusted according to the readings of this pressure gauge.



Canister for Pesticide Information

This canister is for storing information about the present pesticide product in the tank - such as labels, instructions and Material Safety Data Sheet (MSDS) from the pesticide supplier.

Information on other products used, such as herbicides, fungicides or liquid fertilizer must also be stored here.

Unscrew the lid and store this information inside the canister at all times when using the sprayer.

The canister is placed on the side of the SafetyLocker.



ATTENTION! Although this canister is meant for the storing of non-contaminated items, it must never be used for the storing of food, beverage or other items meant for human consumption.



ChemLocker

A ChemLocker for storage of chemical containers or bags is mounted on the sprayer's right side.



ATTENTION! Maximum load is 220 lb (100 kg).



SafetyLocker

The locker is integrated just above the SmartValves.

It is used for storing non-contaminated protective gear, soap for hand washing etc.

The locker is split in two compartments for the separation of clean items from gloves with risk of contamination and includes a strap (A) to secure a soap dispenser.

To open the SafetyLocker, place your hand in the bottom right hand corner of the side shield (white arrow) and pull to open.



WARNING! Although this locker is meant for storing non-toxic items, it must never be used for storing food, beverages or other items meant for consumption.

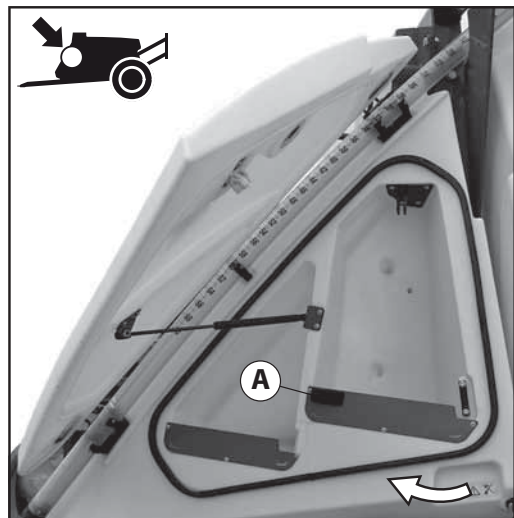

3 - Description

Drawbars

Rigid Drawbar

The COMMANDER 4500 is equipped with a rigid drawbar. The swivel hitch (Ø50 mm) is welded to the drawbar.

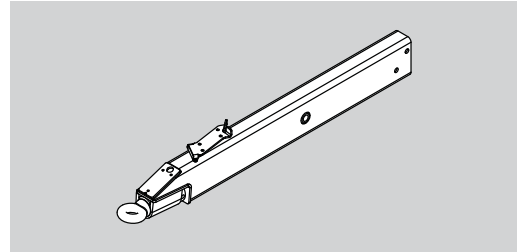

Suspended Drawbar

For COMMANDER 5500 and 7000 models the drawbar is fully suspended.

The full up and down load from the sprayer to the tractor are transferred through rubber dampers built into the chassis.

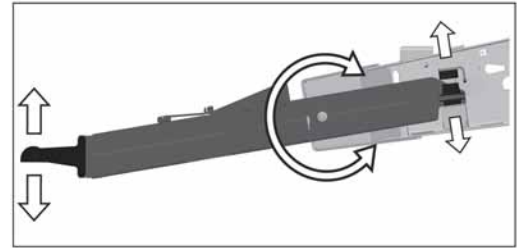

Hydraulic Support Leg CM5500/7000

This support leg supports the sprayer at the front, when it is not coupled to a tractor. When coupling the sprayer to a tractor, the support leg can be raised or lowered to adjust the sprayer to fit the tractor's hitch point.

See "Hydraulic Support Leg CM 5500/7000" on page 49 for instructions on how to use the support leg.

Illustration of the support leg (B) when standing on the ground. The support leg is stored in its retracted position when the sprayer is attached to the tractor.

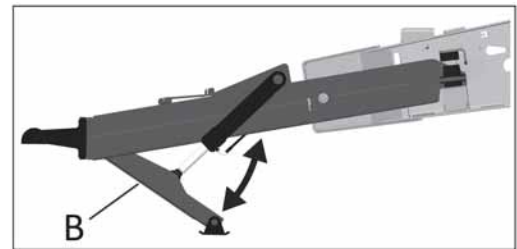

SafeTrack

The SafeTrack will make the sprayer automatically follow the tractor's back wheels when turning in the field, e.g. at headlands. The SafeTrack can easily be operated with the hydraulic control unit. SafeTrack has an integrated safety feature which prevents oversteering when the driving speed is too high for the given turning radius. If a TankGauge is fitted, the tank fluid level is also taken into account.

Advantages with SafeTrack:

- A small turning radius
- Better precision when turning



WARNING! The operator is responsible for setting the speed limit for SafeTrack after taking into account the terrain and driving skills.

Ask you HARDI® dealer if this setting is to be changed.



WARNING! During road transport, the drawbar must be aligned in center position. For more instructions, please refer to the instruction book for the controller in the tractor cabin.

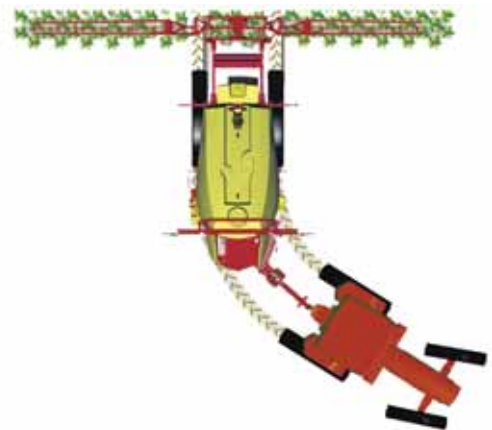

Tank Level Indicator

Main Tank

The actual liquid level in the main tank can be observed on the tank level indicator (A), where a plug (B) inside the tube follows the liquid level, as it is connected to a float inside the tank.

The scale is displayed in US gallons or Liters.



ATTENTION! The level indicator is only a guidance for the liquid level in the tank.

For the most accurate reading, park the sprayer on level ground with the sprayer chassis in a horizontal position.

The total deviation of accuracy for the level for each scale mark or readout value is:

- ± 15 % for volumes up to 10 % of the nominal tank volume.
- ± 7.5 % for volumes between 10 and 20 % of the nominal tank volume.
- ± 5 % for volumes above 20 % of the nominal tank volume.



Rinsing Tank

The actual water level in the Rinsing Tank can be observed in tube (C).

A yellow ball floating inside the tube indicates the water level.

- The ball is at the top of the tube: A full tank.
- The ball is at the bottom of the tube: An empty tank.

The numbers integrated in the red plate to the right of the tube also indicate the water level.



3 - Description

External Cleaning Device

This equipment comprises a hose reel and a spray wand (C) used to clean the complete sprayer externally in the field with clean water. The External Cleaning Device wand (C) is located on the sprayer's right side behind the ChemLocker cover.

Ball valve:

- A. Open
- B. Closed



ATTENTION! Do not let go of the hose. Gently restrict the roll-in of the hose.



DANGER! The cleaning device produces a water jet with high pressure. Incorrect use may result in injuries!

When using the cleaning device, follow these rules:

- Wear personal protective equipment on your body, feet, hands and head. Particles and chemical residues can hit you during the cleaning.
- Any helpers must also wear protective equipment. Keep bystanders at a safe distance.
- Never point the water jet at people, animals, electrical installations or other sensitive objects.
- Never use the water jet to clean clothing or footwear.

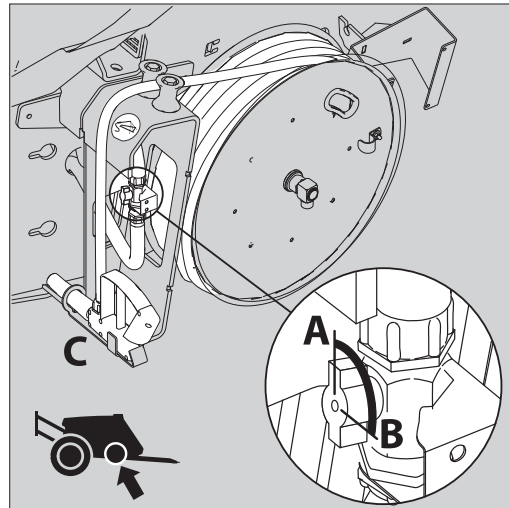

Night Spraying Light

Floodlights (A) are mounted on the spray boom, and they are positioned to illuminate both boom wings when spraying at night.

The work light lamp (B) is also mounted to the railing of the platform above the valves. This lamp is positioned to light up the TurboFiller and the valve system.

The boom lights (A) are turned on/off on the controller in the tractor.

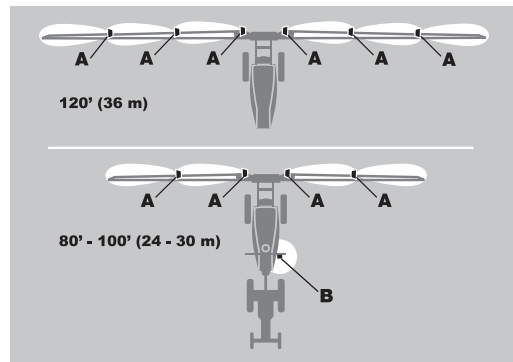

The work light (B) is turned on/off by activating a switch (D) inside the left side cover (C). Open the cover to turn on the light.



ATTENTION! It is recommended to switch OFF the rear working lights of the tractor in order to save power consumption and to avoid reflection. Power supply is via the 2-pin socket - for more information, see "Boom and Work Lights" on page 156.

Turn OFF all work lights and night lights when driving on public roads!

If the lights do not function, check the cable connections (see "Boom and Work Lights" on page 156), and check if the fuses are blown.

Check frequently that the lights are clean and undamaged. Clean with a dry cloth if needed. Replace if broken.

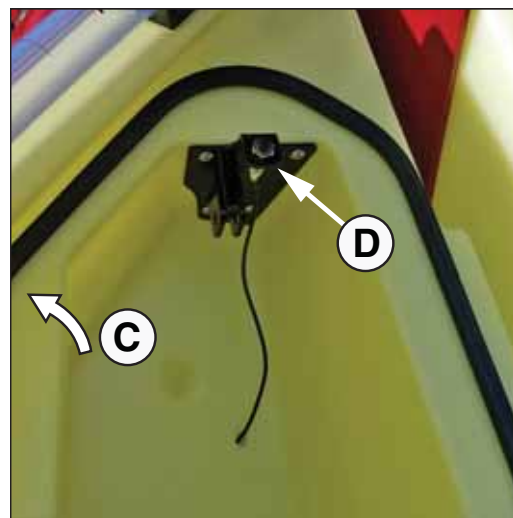

Paralift Lock Brackets

With the spray boom folded in transport position, the paralift is locked in position. This is to prevent accidental movements of the boom while driving on the road.

Description of the Lock Mechanism

The hydraulic cylinder (A) for the paralift extends fully to raise the boom into transport position.

A lock bracket (B) will then automatically be lowered onto the extended piston rod by means of another hydraulic cylinder (C), when the boom is fully folded.

The lock bracket will now prevent the piston rod from retracting unintentionally during road transport, if the hydraulic pressure drops. The lock bracket helps to ensure a safe transport position of the boom.



WARNING! During road transport, it is important that the lock bracket is in the lock position. If not, it could cause a dangerous situation, if the hydraulic pressure drops. Risk of the boom gliding out of the transport brackets, resulting in damage to the mudguards for the wheels and further damage to the sprayer. The extent of the damage depends on the sprayer size and boom size; however this damage is depending on other components failing as well.

Service Situation



DANGER! In a service situation, it is very important that the lock bracket (B) is in the lock position. If the hydraulic pressure drops, when you are standing below the paralift, it could cause a dangerous situation, as the paralift will be lowered quickly.

Risk of squeezing and getting trapped. Risk of fatal accidents.

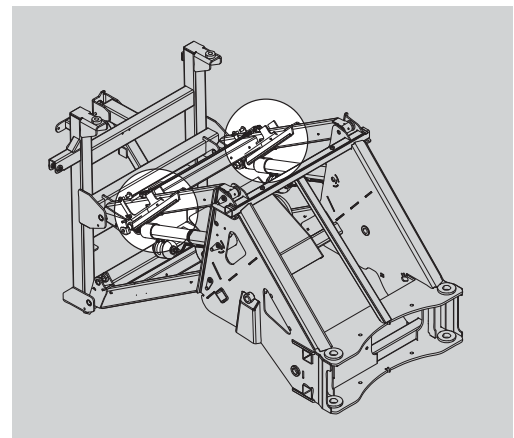

3 - Description

General Info

Unloading the Sprayer from the Truck

For the unloading of the sprayer, you need a crane. When unloading with a crane, please observe the lifting points as shown in the picture, and make sure that the straps or belts used for lifting are strong enough.



ATTENTION! Only lift the sprayer when the tanks are empty!

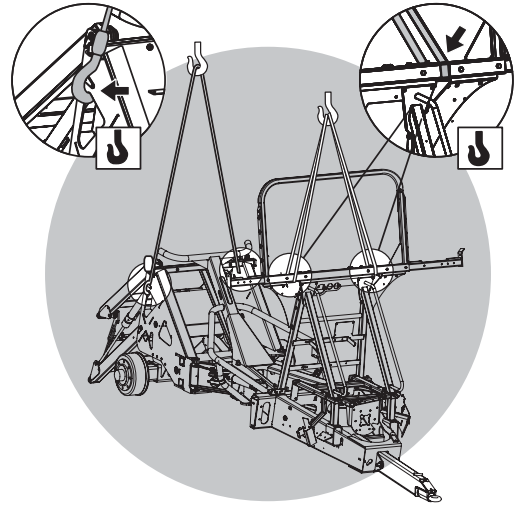

Pulling the Sprayer at the Tie Down Points

When moving the sprayer or loading it onto a truck, it can be pulled by the hooks at the rear end (A) and front end (B) as shown.

CM 4500

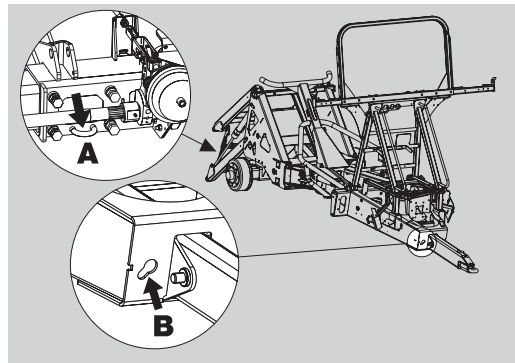

CM 5500/7000

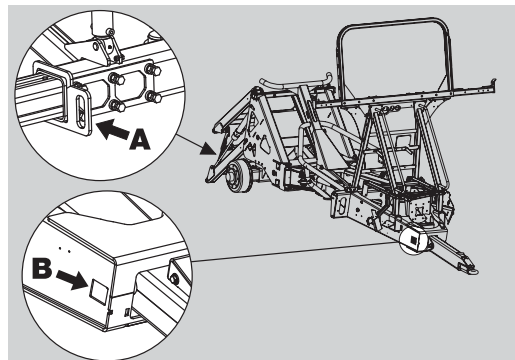

4 - Sprayer Setup

Before Putting the Sprayer Into Operation

Although the sprayer has been supplied with a strong and protective surface treatment on steel parts, bolts etc. in the factory, it is recommended to apply a film of anti-corrosion oil (e.g. CASTROL RUSTILO or SHELL ENSIS FLUID) on all metal parts in order to avoid chemicals and fertilizers discoloring the enamel.

If this is done before the sprayer is put into operation for the first time, it will always be easy to clean the sprayer and keep the enamel clean for many years. This treatment should be carried out every time the protection film is washed off.

Jack Up the Sprayer

When the sprayer needs wheel mounting, wheel changing or wheel bearing maintenance, jack up the sprayer under the axle as shown.

Notice the axle load in the section "Weight" on page 150, and use a suitable jack and stands for the task.



DANGER! Be sure to place sprayer at level and firm ground to prevent the sprayer from falling down from the jack. For your safety:

- use chocks at the opposite wheel to prevent rolling.
- connect the sprayer's drawbar to a tractor to help balance the sprayer on the jack.
- place strong stands below the wheel axle once it is jacked up. The jack alone is only for lifting and lowering the sprayer.

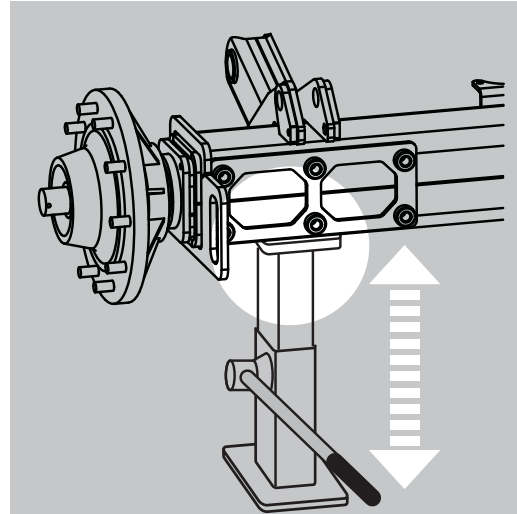

Support Jack CM4500

The support jack is stored in retracted position and secured by a spring loaded pin when the sprayer is attached to the tractor.

To retract the support jack:

Pull the knob (A) to fold up/down the support leg to/from its storage position.



4 - Sprayer Setup

Hydraulic Support Leg CM 5500/7000

The hydraulic support leg is activated via a separate double acting hydraulic outlet on the tractor. Connect the hydraulic hoses from the support leg to the tractor and test the function of the support leg carefully.

The support leg is positioned in its retracted position, when the sprayer is attached to the tractor.

1. The sprayer's drawbar is connected to the hitch point on the tractor. The support leg (B) is hydraulically raised/lowered.

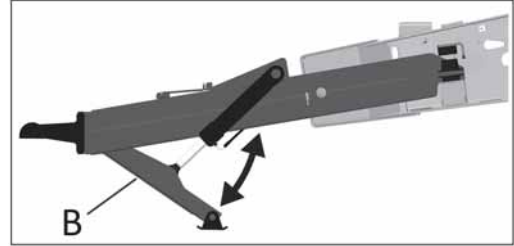

2. Unlock the leg by turning the securing lever to position (A).
3. Use the tractor's hydraulic lever to raise or lower the support leg.
4. Secure the support leg by turning the lever to position (B).

 **DANGER!** Always double check that the lever is in the locked position (B) when leaving the sprayer standing on the support leg.

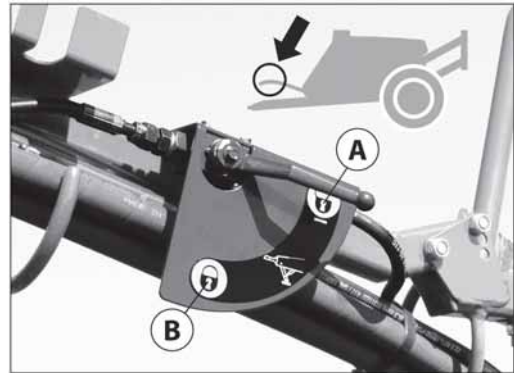

4 - Sprayer Setup

Transmission Shaft

Operator Safety

1. Always read the manufacturer's instruction book before applying any changes to the transmission shaft!
2. Always STOP THE ENGINE and remove the ignition key before carrying out maintenance or repairs to the transmission shaft or implement.
3. Always STOP THE ENGINE before attaching the transmission shaft to the tractor power take-off (PTO). Most tractor PTO shafts can be rotated by hand to facilitate spline alignment when the engine is stopped.
4. When attaching the shaft, make sure that the snap lock is FULLY ENGAGED - push and pull the shaft until it locks.
5. Always keep protection guards and chains intact and make sure that it covers all rotating parts, including CV-joints at each end of the shaft. Do not use without protection guard.
6. Do not touch or stand on the transmission shaft when it is rotating - keep your safety distance: 5' (1.5 meter). Also NEVER cross over a rotating PTO shaft to reach the other side of the sprayer.
7. Prevent protection guards from rotating by attaching the chains, allowing sufficient slack for turns.
8. Make sure that protection guards around the tractor PTO and the implement shaft are intact.

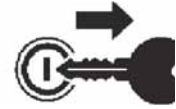

DANGER! A ROTATING TRANSMISSION SHAFT WITHOUT PROTECTION GUARDS CAN BE FATAL!

PTO Installation

First installation of the transmission shaft is done in the following way:

1. Attach the sprayer to the tractor and set the sprayer height in the position with the shortest distance between the tractor and the sprayer pump PTO shafts.
2. Stop the engine and remove the ignition key.
3. If the transmission shaft needs to be shortened, pull the shaft apart. Fit the two shaft parts to the tractor and the sprayer pump and measure how much the shaft needs to be shortened. Also mark the protection guards with the same length to be shortened.



WARNING! Only shorten the shaft if it is absolutely necessary!



The shaft must always have minimum overlap (A) of 1/2 of the length.

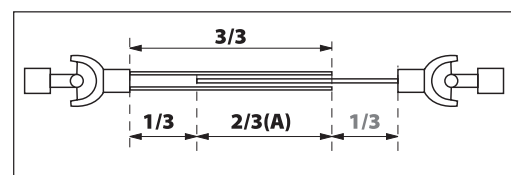
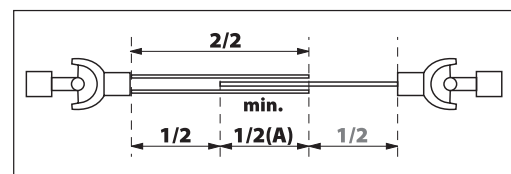
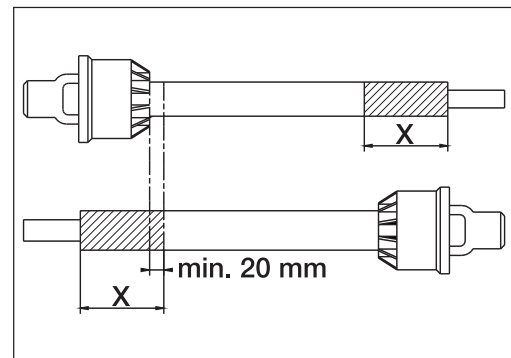

The recommended overlap (A) of the two shaft parts is 2/3 of the length.

Mechanical Connections

Hose Package Support

To prevent hoses and wiring from being damaged by the tractor wheels or the PTO shaft, all hoses, cables and wires are held by the hose package support fitted to the sprayer platform.

The bracket (A) is for the storing of hydraulic and electric connectors etc. when the sprayer is disconnected from the tractor. The height of the bracket can be adjusted by the means of the bolts (B).

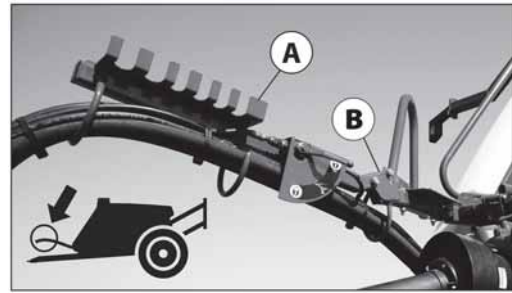

ATTENTION! Check that the length of the hoses and cables are long enough in tight turns.



ATTENTION! A sprayer with steering requires more slack in the cables. Make sure that the hoses and cables are long enough in tight turns when fully steered.

SafeTrack Potentiometer Connection

When connecting the SafeTrack sprayer to the tractor, it is important to set up the front potentiometer on the drawbar correctly. The potentiometer must be connected to the tractor with the 2 supplied chains.

To ensure a high precision:

- The chains must be parallel and horizontal.
- The tractor hitch point may not have any sideways movement.

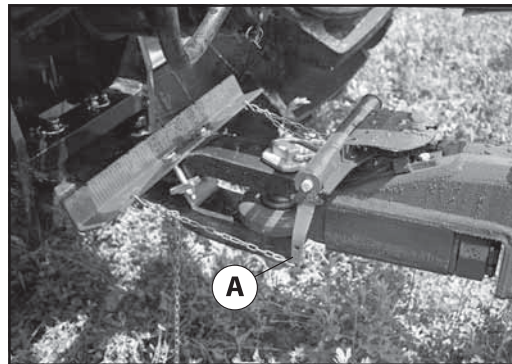

Procedure when connecting the sprayer to the tractor:

1. Connect the sprayer.
2. Drive forward to ensure the sprayer follows the tractor in a straight line, and then stop.
3. Connect the two chains for the potentiometer, while ensuring the transverse potentiometer bar is perpendicular to the drawbar. The chains must be parallel and horizontal, and tightened so that the torsion levers (A) are vertical.
4. Enter the controller menu. Check if the front potentiometer is reading 2.50 Volts in center position.
HC 6500 / ISOBUS VT: [Menu 4.5.4.6 Track sensor test]. Check if the front sensor reading is 2.50 Volts.
5. If the voltage reading is not correct, then adjust the chain connection until voltage = 2.50 Volts.
Allowable deviation is ± 0.05 Volts.
6. Fine-tuning is carried out by loosening the screws for the potentiometer.

4 - Sprayer Setup

Hydraulic System

General Info

Ensure that the snap couplers are clean before connection!

After having operated the boom and the system has been filled with oil, check the tractor's hydraulic oil level and top up if necessary.



DANGER! Test of the hydraulic system should be done very cautiously. There may be air trapped in the system which can cause violent movements of the boom.



DANGER! Hydraulic leaks: Never use your fingers to locate a leakage in any part of the hydraulic system. Due to high pressure, hydraulic oil may penetrate the skin.

Requirements for Tractor

The hydraulic system requires:

- One double-acting outlet for the electro-hydraulic operation of the boom functions.
- One double-acting outlet for operating the FlexCapacity pump (optional equipment).
- One double-acting outlet for operating the hydraulic support leg (CM 5500/7000).



ATTENTION! The hydraulic hoses are marked with arrows to indicate the direction of oil flow. The hoses must be hooked up to the correct outlet for the hydraulics to function properly (pressure hose to pressure outlet, return hose to tank outlet).

- Oil flow between 7 - 24 gal/min (25 and 90 l/min) and a minimum pressure of 2600 p.s.i. (180 bar).
- Maximum permissible oil pressure is 3000 p.s.i. (210 bar).
- Return flow restriction of the connected tractor must be maximum 145 p.s.i. (10 bar).
- For Load Sensing systems, an oil flow of approximately 1.3 gal/min (5 l/min) at 360 p.s.i. (25 bar) is supplied by the sprayer hydraulics. If a greater flow is required, a different orifice must be installed between the "open center" hydraulic block and the load sensing (LS) hydraulic line - see "Open and Closed Center Hydraulics" on page 53 for more information.

Open and Closed Center Hydraulics

This hydraulic block is necessary if the tractor uses open center hydraulics and/or load sensing (LS).

The valves (pos.1 and 2) are factory set for open center hydraulics, but if closed center hydraulics is used (also in combination with load sensing), screw in the valves clockwise.



WARNING! Always be sure to fully open or close the selection valves for open/closed center hydraulics.



NOTE! The hydraulic block is accessed from below the sprayer chassis.

Certain tractor models are able to use Load Sensing without connecting an external sensing line. But if optimal sensing control pressure cannot be obtained, an external sensing line needs to be connected to the tractor.

Connection to Tractor

If Load Sensing (LS) is to be used, connect a hydraulic hose from the tractor's LS port to the O-LS port (D) on this hydraulic block.

Connection size for port D is G1/4".

The restrictors inside the hydraulic block have different orifices depending on the oil flow returned to the tractor's oil pump.

- A. Orifice is $\varnothing 0.8$ mm (default setting).
- B. Orifice is $\varnothing 1.2$ mm
- C. Orifice is $\varnothing 1.6$ mm
- Check the hydraulic flow by activating a hydraulic lever in the tractor. If the reaction time for the hydraulic function is relatively short, continue your work with this restrictor installed.
- If the reaction time seems too long before the hydraulic function is enabled, switch the plug (E) in port (A) with the plug (F) in port (B) to allow more oil flow to pass through.
- If the reaction time is still too long, switch the plug (E) in port (B) with the plug (F) in port (C).
- Always mount the plug (E) in the port used, and mount the other plugs (F) in the ports not used.
- Ask your HARDI® dealer for correct setup if in doubt.

Combinations of settings for hydraulic block:

| Application | Valve 1 | Valve 2 | Port A, B or C |
|-------------------|---------|---------|------------------|
| Open center | Out | Out | No change |
| Closed center | In | In | No change |
| Load sensing (LS) | In | Out* | Change if needed |

*If the tractor requires pressure relief, contact your tractor dealer for further advice.



WARNING! It is essential that connectors on the sensing line are kept totally clean, so that impurities do not enter the pump. Impurities may cause damage to vital pump parts.

Before operating the hydraulics, the valve should be set according to the specific tractor model. If you are unsure of the type of hydraulic system in your tractor, please contact your tractor dealer.



4 - Sprayer Setup

Electrical Connections

Power Supply

Power requirement is 12 V DC. Always note the polarity!

For proper function of the electric equipment for the sprayer, the tractor must have the following sizes of electric wires and fuses installed.

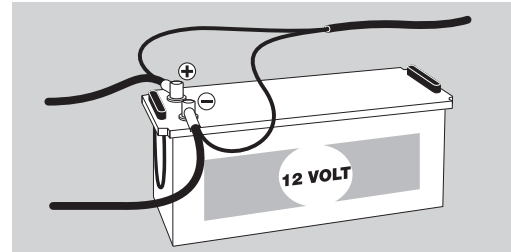

Spray box connector, 1-pin plug

The unit requires:
Wire 12 awg (2.5 mm²), Fuse 10 amps.

Hydraulic control unit requires:
Wire 10 awg (4.0 mm²), Fuse 16 amps.

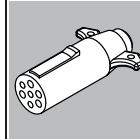

Traffic light connector, 7-pin plug

Tractor must follow ANSI/ASAE S279.11.



JobCom connector, 3-pin plug

The unit requires:
Wire 6.0 mm². Fuse 25 amps.

Tractor must follow DIN 9680.

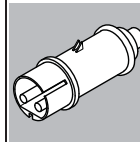

Working light connector

The unit requires:
Wire 10.0 mm², Fuse 30 Amp



ISOBUS connector, 9-pin plug

The cable is custom made and must not be changed to another type.

Tractor must follow ISO 11783-2.

Cabin connector for grip control and Setbox:

HARDI® item no. 26031500



Power and data connector, 13-pin plug

Used for controller model HC 6500.

If needed, buy one of these tractor kits to complete the setup:

HARDI® item no. 26049400 (incl. NORAC system)

HARDI® item no. 26013900 (excl. NORAC system)

Tractor must follow ISO 11446.

The delivered power connectors follow the standard of most modern tractors. If you have a tractor with another power connector, it is necessary to disassemble the connector and fit it to the actual sprayer connector. Contact your HARDI® dealer.

The delivered connectors may vary on the sprayer, depending on its equipment and scope of supply.

Road Safety Kit

Connect the plug for rear lights to the tractor's 7-pin socket and check the function of rear lights, stop lights, side lights and direction indicators on both sides before driving.

The wiring is in accordance with ANSI/ASAE S279.11. See "Electrical Connections" on page 155.

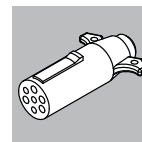

ATTENTION! Turn OFF all work lights when driving on public roads!

4 - Sprayer Setup

Installation of Control Unit Brackets

Find a suitable place in the tractor cabin to mount the control units. Best recommended position is to the right of the driver seat.

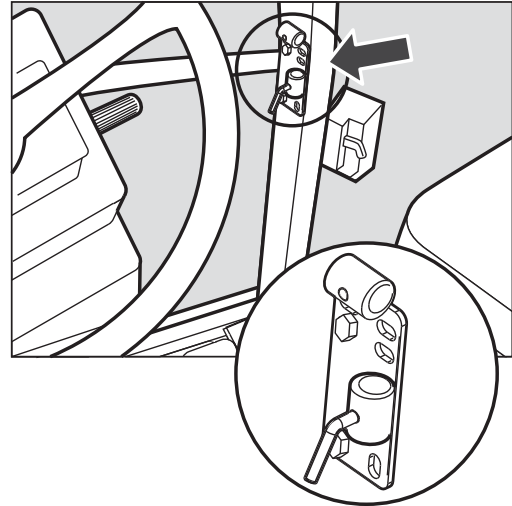

The supplied tractor pillar bracket (A) has a hole spacing of 3.9 in. (100 mm) and 4.7 in. (120 mm), which fits most tractors. Threaded mounting holes may be hidden behind front corner cover. Check the tractor's instruction book for information regarding attachment points.

Three mounting tubes (B) are supplied. One, two or all three may be used. They can be bent and shortened. A spacer (C) is also supplied to allow further attachment possibilities. Find the best solution for your tractor or vehicle.

Tube (B) plate is staggered so that, if correctly orientated, all boxes will line up.



ATTENTION! See also the controllers instruction book for further details of fitting the controller equipment.

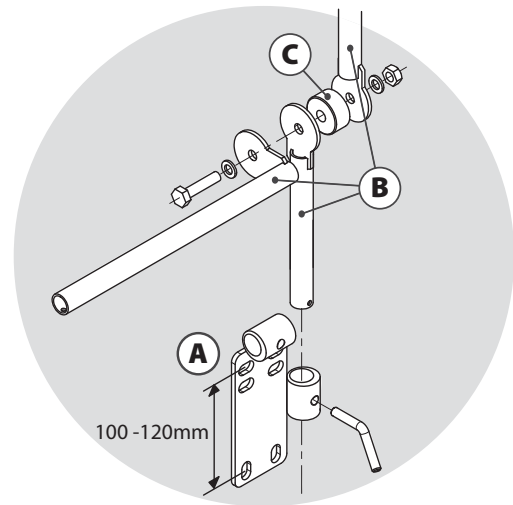

4 - Sprayer Setup

Speed Sensor for Sprayer

The speed sensor and speed ring are located at the inside of the sprayer's right wheel. The sensor is an inductive type that requires a metallic protrusion like a speed ring to pass by it to trigger a signal.

Adjustment (Sprayers built before 1/1/2020)

1. Assure that the speed ring is correctly fitted to the wheel, so that the arrow (A) follows the rotation of the wheel in the forward driving direction.
2. Check that the sensor lines up in the (radial) center of the air gaps from bottom/inside to top/outside of the speed ring.
3. If necessary, adjust plate on axle.
4. Adjustment of air gap (B) begins with the sensor directly opposite one of the carriage bolts holding the speed ring.
5. Adjust air gap (B) to 1/8" (3.0 mm). Use feeler gauge or similar tool.
6. After adjustment, rotate the wheel. Verify air gap variation of less than ± 0.02 " (± 0.5 mm). Check this for the entire circumference.
7. Verify the speed on the controller.



ATTENTION! Correct fitting is indicated by continuous flashing from the transducer when the wheel rotates.

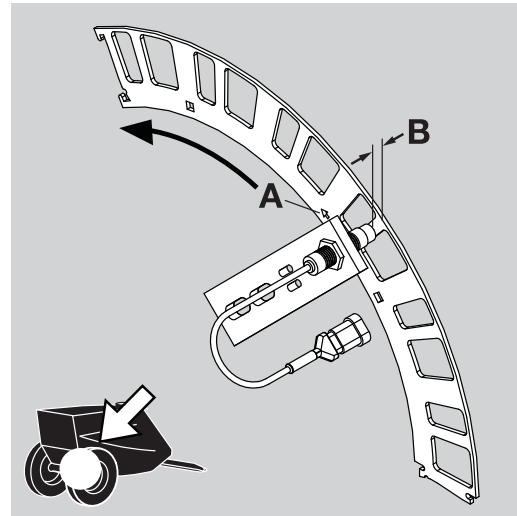

Adjustment (Sprayers built after 1/1/2020)

1. Assure that the speed ring is correctly fitted to the wheel, so that the arrow (A) follows the rotation of the wheel in the forward driving direction.
2. Check that the sensor lines up in the (radial) center of the air gaps from bottom/inside to top/outside of the speed ring.
3. If necessary, adjust plate on axle.
4. Adjustment of the air gap (B) begins with the sensor directly opposite one of the carriage bolts (C) holding the speed ring.
5. Loosen the clamp (D) to move the sensor (E) in or out of the red tube. Re-tighten the clamp when finished.
6. Adjust the air gap (B) between sensor and speed ring to 5/32" (4 mm). Use a feeler gauge or similar tool.
7. After adjustment, rotate the wheel. Verify air gap variation of less than ± 0.02 " (± 0.5 mm). Check this for the entire circumference.
8. Verify the speed on the controller.
9. ATTENTION! Correct fitting is indicated by continuous flashing from the transducer when the wheel rotates.

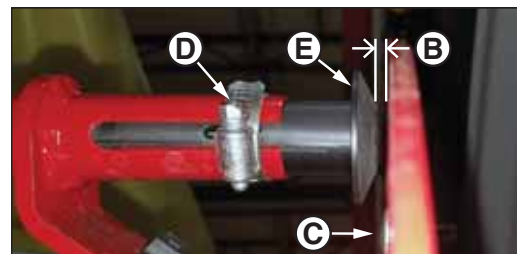

Liquid System

CycloneFilter

Standard filter size is 80 mesh and can be changed by opening the filter top.

Check condition of O-rings and lubricate if necessary, or replace them if damaged, before reassembly.



DANGER! Never open the CycloneFilter unless the pressure SmartValve is closed (turned to unused function).

Otherwise spraying liquid may hit you when opening the filter, and drain from the main tank!

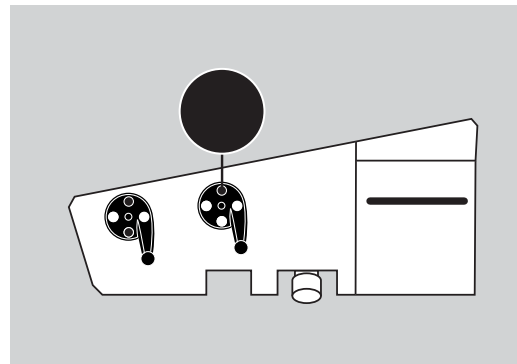

4 - Sprayer Setup

Spray Boom

Boom Movements When Spraying

The operator of the sprayer must consider the field conditions before spraying, as this could include a change to the boom setup regarding suspension and damping.

The object is to have the unfolded boom aligned parallel to the ground when driving in the field, as this will optimize the spraying.

At delivery, the spray boom is normally set in a neutral position (2), meaning that the unfolded boom will follow the movements of the sprayer's wheel axle to some extent = an active boom. This works for many field conditions.

The trapeze in the boom center can be adjusted, if you need another setup.

This is relevant for sloping fields and for uneven or bumpy driving tracks.

Mechanical Adjustment of Guide Rods

The guide rods (A and B) can be moved to another position to make the boom follow the wheel axle movements even more when driving in the field.

The guide rods are either parallel to each other (1) or angled (2):

1. Parallel: Neutral boom damping - active boom which only partly follows the wheel axle movements.
2. Angled: Hard boom damping - passive boom which mainly follows the wheel axle movements.

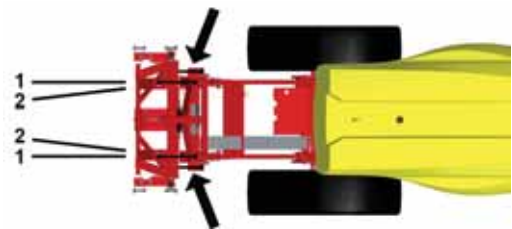

Adjustment of the guide rods requires two persons, as the boom center structure needs to be handled to make the guide rods fit into the other hole positions.

The photo shows neutral position of the two guide rods (A and B) located at the top of the boom center.



Moving the Guide Rods at the Top

1. Loosen the nuts below both rod connections next to the free hole (see arrows).
2. Move the rods to the free hole position.
3. Mount the nuts with a torque of 185 Ft/lb (250 Nm).

Tools Needed

Torque wrench, size 27 mm



Moving the Guide Rods at the Bottom

To make the boom even more passive, move the two guide rods at the bottom of the boom center.

1. Loosen the nuts below both rod connections next to the free hole (see arrow).
2. Move the rods to the free hole position.
3. Mount the nuts with a torque of 185 Ft/lb (250 Nm).

i These guide rods angle outwards, which is opposite to the guide rods at the top.

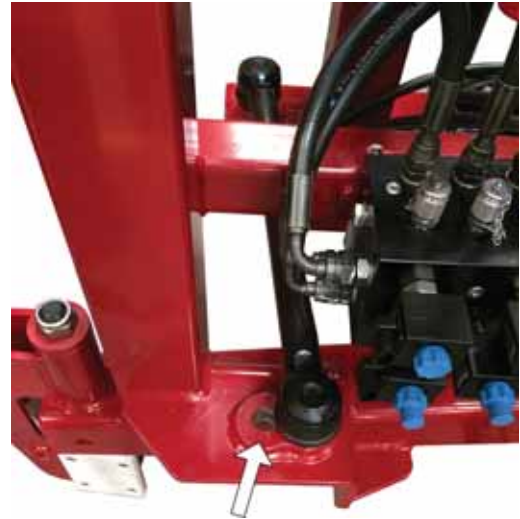

4 - Sprayer Setup

Adjustment of Trapeze Damping

After adjusting the boom suspension mechanically, it is possible to fine-tune the boom movements in the field if needed.

This is done with the damping control. It is located in the boom center below the hydraulic cylinder, which affects the boom damping.

By adjusting the valve here, the hydraulic oil flow is changed.

1. Loosen the jam nut.
Screw the throttle valve (A) inwards until the stop.
Turn it 3 full turns outwards (= factory setting).
2. Now test the damping of the boom; see the following sections.
3. More boom damping: Screw the throttle valve inwards.

Less boom damping: Screw the throttle valve outwards.

The valve is very sensitive - only make small adjustments before testing the boom damping. It will now react immediately, and depending on the setting for boom damping, the boom will more or less follow the sprayer's wheel axle movements.

4. Tighten the jam nut when finished.

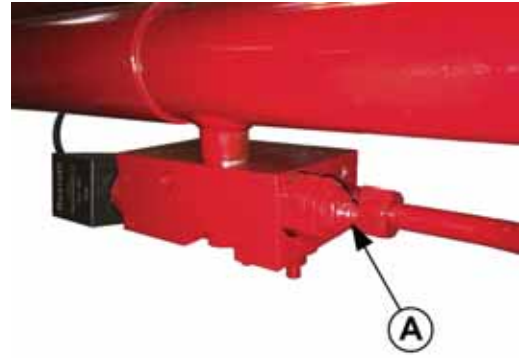

Tools needed:

Size: 17 mm



Size: 5 mm



Testing the Trapeze Damping

After adjusting the boom suspension mechanically or electrically, always test the boom damping by hand and re-adjust if needed.

Before testing:

- Park the sprayer and activate the tractor's brake.
- Unfold the boom and adjust the boom height to approx. 5' (1.5 meters) above the ground.
- Unlock the boom center .
- Stand next to the boom. Ensure that there are no cables etc. or excessive wear on the boom which can prevent a free vertical movement of the boom.

4 - Sprayer Setup

Correct Damping

Illustration of the test:

A.

Note the boom height. Push the boom tip down to the ground.

B.

Hold the boom steady for a moment and release it.

C.

Check that the boom returns to its starting position as quickly as possible, with little or no overshoot.

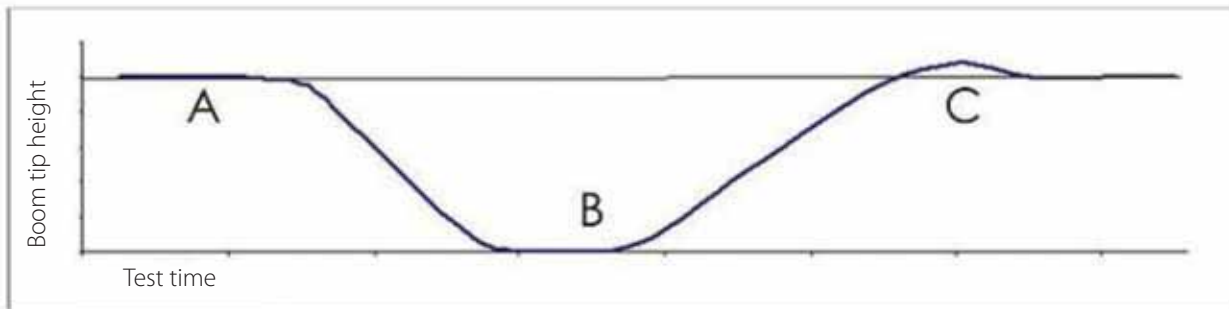
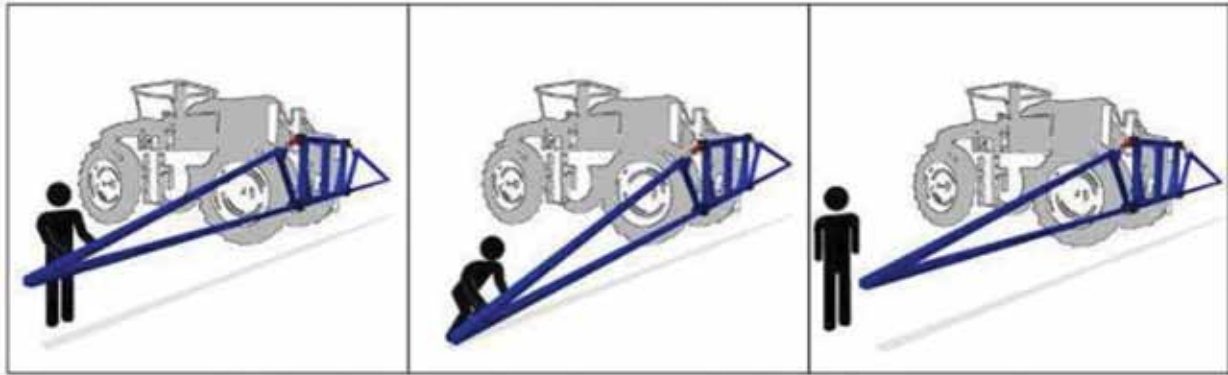

4 - Sprayer Setup

Adjustment of Boom Folding Speed

The main hydraulic block manages hydraulic pressure for the boom controls.

The throttle valve (A) can adjust the folding speed of the boom.

Check the Folding Speed

- Unfold the boom.
- Fold the outer boom sections calmly into the transport position without crashing hard against the other boom sections.

The folding speed is set from factory. However, it may be adjusted before use of the sprayer if the operator finds it necessary.

Factory setting:

The valve is screwed completely in and 1/2 turn back out.



ATTENTION! The throttle valve only needs slight adjustments to change the speed significantly.



ATTENTION! If the boom moves too fast:

Risk of premature wear and tear.

Risk of damaging the boom parts.

To Decrease Folding Speed

- Loosen the jam nut.
- Screw the valve inwards.
- Tighten the jam nut again.

To Increase Folding Speed

- Loosen the jam nut.
- Screw the valve outwards.
- Tighten the jam nut again.



ATTENTION! The system must be unpressurized during the adjustment.

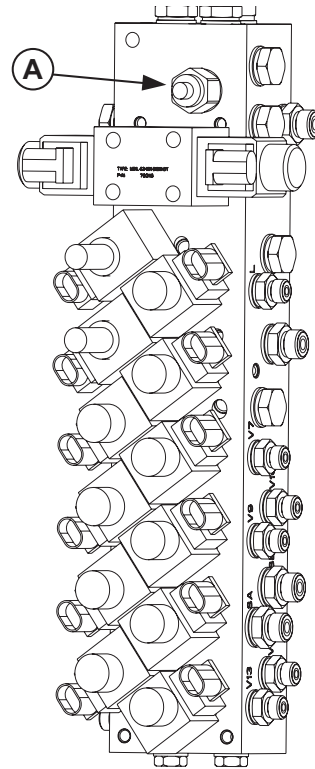

Tools Needed

Size: 17 mm



Size: 5 mm



Damping of Boom Folding Speed

Selecting the Speed

The folding cylinders can be adjusted to dampen the speed of folding / unfolding, when the cylinder piston approaches its end stop at extension or retraction.

- If the folding is too fast, the boom sections will hit each other hard, resulting in unnecessary damage to the boom parts.
- A very slow folding / unfolding of the boom, however, will be time consuming.

The speed of folding / unfolding the boom is an individual decision, which also depends on the tractor capacity.

The speed is adjusted from the factory, but can be re-adjusted once your tractor and sprayer are connected.

Tools Needed

Size: 13 mm.



Size: 6 mm



Adjusting The Speed

The folding cylinders have throttles, which can be adjusted to increase or decrease the boom folding speed.

Approximately 2 inches (50 mm) of the piston stroke is adjustable in both ends.



1. Turn the Allen bolts to throttle the oil flow for adjusting the folding speed. The jam nuts are adjusted accordingly.
Only small adjustments of the throttles are required!
- Slower speed - turn throttle clockwise.
 - Faster speed - turn throttle anticlockwise.

The two throttles on each hydraulic cylinder work independently, so that folding / unfolding of the boom can be adjusted separately.

2. After adjustment, fold/unfold the boom and check that the desired speed is achieved.
3. If not, adjust the throttles again.

4 - Sprayer Setup

TWIN Air System

Adjusting the Air Assistance

The air speed and angling must always be adjusted individually for each spray job and the given weather conditions. It is always a good idea to get used to a new sprayer out in a field with only water in the tank. The following routine for air adjustment should be practiced:

1. Start with a vertical air stream (no angling).
2. Set the air speed: See the next section "Setting the air speed - Rules of Thumb" below.
3. Find the best angling: See "Angling of Air and Spray Liquid - Rules of Thumb" on page 65.



ATTENTION! Fine tuning of air speed and angling will often be necessary during the spraying job.

It is easiest to find the best air setting to reduce drift when the sun is low and behind the boom. This condition makes the drift more visible.

Setting the Air Speed - Rules of Thumb

Step 1

Find the range of air speeds that causes a minimum drift of the spray mist.

1. Start with the air setting at zero and keep increasing the air speed to the point where you can just begin to see that the drift cloud is minimized - note the minimum setting.
2. Increase the air speed, until you see drift again - note the maximum setting.
 - Bare ground / low crop: The range of air speeds is usually very small. Too high an air speed can cause reflection of the spray liquid and leave dust on the leaves, which again reduces the effect of the plant protection product.
 - Taller crop: The taller the crop, the wider the range of air speeds that can reduce drift.
 - At higher wind speeds: More air is needed from the sprayer and it is advisable to drive slower and use minimum boom height (15 in. / 40 cm).

Step 2

Set the optimal air speed within the possible range noted.

Air speed recommendations:

- Bare ground / low crop: Use low air speed within the possible range.
- Taller crop / dense crop: Deeper crop penetration requires more air on the sprayer (if you are in doubt, test with water sensitive paper).

Driving speed:

- Higher driving speeds require more air on the sprayer.

Volume rate:

- Lower volume rates require more air assistance to prevent drift.

4 - Sprayer Setup

Angling of Air and Spray Liquid - Rules of Thumb

To control wind drift, the influence of wind speed and wind direction, as well as the horizontal air current around the boom due to forward speed must be minimized. Because it is a sum of two forces with variable direction and size that we have to counteract for, the following can only be very rough guidelines.

Angling of Air System

The air system can be angled to counteract for the wind direction and high driving speeds.

Angling the air system forwards: Up to 40°.

Angling the air system backwards: Up to 30°.

No angling (neutral setting): 0° = the spray nozzles points vertically towards the ground.

The angle between the spray nozzles (A) and air channel (B) is fixed.

Wind Direction

- Head wind: Angle the air stream forward.
- Tail wind: Angle the air stream backwards (if the forward speed is higher than the wind speed: angle forward).
- Side wind/no wind: Angle the air stream vertically or backwards.

Only high driving speeds may require forward angling.

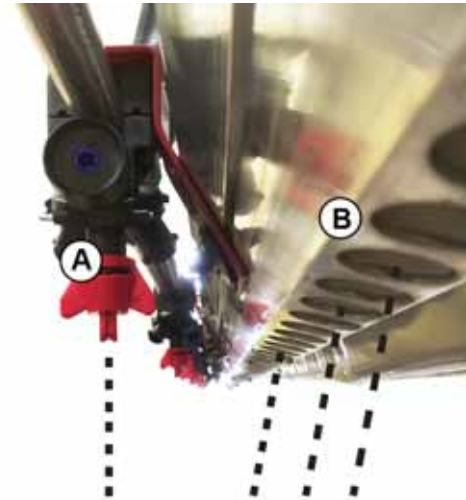

Angling forwards



Angling neutral



Angling backwards



4 - Sprayer Setup

Spray Tips

Bare ground/low vegetation: Low air speed and angling backwards will often be the best setting to avoid reflection of spray liquid.

Dense crop: The angling feature is ideal to help opening the crop rows and improve penetration. If you follow the crop movement as you are varying the angling, you will find that at certain settings the crop will open more for penetration.

If wind speed, wind direction or forward speed changes during spraying, the optimal angling is likely to change too. Be aware that with certain combinations of air speed and angling, you can "close" or flatten the crop and make penetration impossible. Follow the crop movement intensively, especially when setting the air assistance and keep an eye on the crop all through the application.

- It is most important that the operator is familiar with the above rules of thumb before using the TWIN sprayer.
- The volume rate can generally be reduced to half of what is applied with a sprayer without air assistance, however with a minimum of 54-64 GPA (50-60 l/ha) at 4-5 mph (7-8 km/h). Exceptions are, of course, liquid fertilizer and herbicides, whose selectivity is based on large droplets that will only stick to the weeds.
- Low drift nozzles can also be fitted on a TWIN sprayer to help reduce drift even further.
- If there is a detailed spraying instruction on the chemical label regarding drop size, spray pressure, spray volume rate etc., this instruction should be followed.



ATTENTION! Often it will be necessary to drive with two different anglings, so that the angling is changed when changing driving direction after turning at the headland.

These settings can be saved and preset on the Setbox in the tractor. For more details on how to do this, see "Operating the Control Unit While Spraying" on page 72.

The presets can be turned on/off on the grip in the tractor while spraying; see "Operating the Grip" on page 70.

Track Width, Axles and Wheels

Altering the Track Width (Adjustable Axle)

The track width of the sprayer can be infinitely adjusted from 60" to 90" as follows:

Altering Procedure

1. Measure the current track width (center RH tire to center LH tire). Each side must be extended or retracted half the desired alteration.
2. Attach the sprayer to tractor and engage tractor parking brake.
3. Place stop wedges in front of, and behind RH wheel. Jack up LH wheel, support and secure sprayer body.
4. Loosen the jam nuts and bolts (A) for LH wheel axle.
5. Extend or retract the axle. A hand cart and a rod will facilitate the operation.
6. Lower the LH wheel.
7. Tighten the clamp bolts (A) to a torque of 185 Ft/lb (250 Nm) and lock the bolts with the jam nuts.
8. Repeat the procedure on RH wheel.
9. Check if the distance from center tire to center of rear frame is equal at RH and LH.
10. Re-tighten bolts and wheel bolts to specified torque after 8 hours of work.

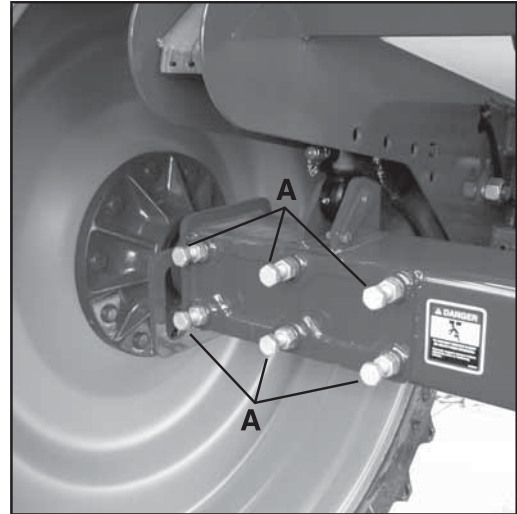

ATTENTION! The wider the track width, the better the stability of the sprayer. HARDI® recommends to work with widest possible track width.



ATTENTION! The track width can be altered in the range from 60" to 90" in combination of above adjustment and turning of the rims (wheel offset).

Changing the Wheel Offset

1. To change the wheel offset, the LH and RH wheels must be swapped in order to turn the rim dish and keep the correct tread direction (tread up in front).
2. Jack up the frame behind both wheels, support and secure sprayer body.
3. Remove both LH and RH wheels and swap sides (keeping the tread direction the same). Tighten wheel bolts to specified torque.

See "50 Hours Service - Wheel Nuts" on page 106 for proper torque and tightening sequence of wheel hubs to rims.



WARNING! Securely support the sprayer while swapping wheels. Never attempt to swap wheels with liquid in the tank. Always secure the rear frame when swapping wheels.

4 - Sprayer Setup

Dual Tire Setup (Optional)

Two different dual tire kits are available for the COMMANDER:

22" row spacing (88"/132"): HARDI® ref. no. 83348403

30" row spacing (60"/120"): HARDI® ref. no. 83348503

1. Attach the sprayer to tractor and engage tractor parking brake.
2. Place stop wedges in front of, and behind RH wheel. Jack up LH wheel, support and secure sprayer body.
3. Remove 8 of the 10 wheel nuts, leaving 2 wheel nuts opposite each other to secure the inner wheel.



NOTE! Longer stud bolts (A) are included for earlier model sprayers with shorter stud bolts.

4. Attach dual spacer (B) or (C) to inner rim using the 8 wheel nuts (D) removed in step 3.

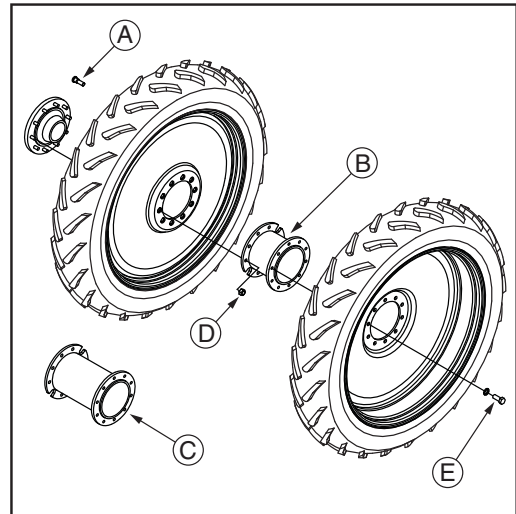

NOTE! Inner side of dual spacer has 2 notches to allow space for wheel nuts left on inner wheel. Outer side of dual spacer is threaded for outer wheel bolts.

5. Attach outer LH tire to dual spacer with supplied wheel bolts and lock washers (E). Make sure the distance between the center of inside tire to center of outside tire is 22" or 30". Wheels may need to be reversed and exchanged.
6. See "50 Hours Service - Wheel Nuts" on page 106 for proper torque and tightening sequence.
7. Repeat the procedure for RH wheels.
8. Re-tighten bolts and wheel nuts to specified torque after 8 hours of work.
9. Check the distance between the center of inside LH tire to center of inside RH tire. The distance must be 88" for 22" duals, or 60" for 30" duals. If necessary, adjust the track width. See "Altering the Track Width (Adjustable Axle)" on page 67.



WARNING! Securely support the sprayer during axle adjustments. Never attempt to adjust axles with liquid in the tank. Always block wheels on opposite side when adjusting axles.









General info

Symbols for Valves

The following symbols are shown on labels on the sprayer, where the operator can set a valve to stop or start a function.

The labels must be readable when operating the sprayer. Damaged or unreadable labels must be replaced.

The symbols are explained here.

| Symbol on label | Symbol description | Label color | HARDI® item number |
|---|---------------------------------------|----------------|--------------------|
|  | Suction from main tank | Black / Blue | 97809900 |
|  | Suction from RinseTank | Black / Blue | 97810000 |
|  | TurboFiller | Black / Green | 97810300 |
|  | Spraying / Pressurized nozzles | Black / Green | 97810400 |
|  | Cleaning of main tank inside | Black / Green | 97810500 |
|  | Agitation in main tank | Black / Green | 97810900 |
|  | Cleaning of empty chemical containers | Black / Yellow | 97821600 |
|  | Agitation in TurboFiller | Black / Yellow | 97821500 |
|  | Filling of main tank from TurboFiller | Black / Yellow | 97821400 |

5 - Operation

Spray Boom

Safety Info

Keep the spray boom in folded position while driving outside the field. Park the sprayer and tractor on level ground before using the folding/unfolding functions. The boom must not be folded/unfolded while driving! Never use the folding/unfolding functions before the sprayer has been stopped!

Failure to do so will damage the boom and cause dangerous situations to people and the surroundings.



DANGER! Before unfolding the boom, it is important to connect the sprayer to the tractor to prevent overbalancing of the sprayer.



DANGER! When folding or unfolding the boom, make sure that no persons or objects are within the operating area of the boom.



DANGER! Always follow the guidelines listed below when driving in areas with overhead power lines:

Keep from using the folding/unfolding functions in areas with overhead power lines. Unintended boom movements may cause contact with overhead power lines, causing a risk of fatal accidents.

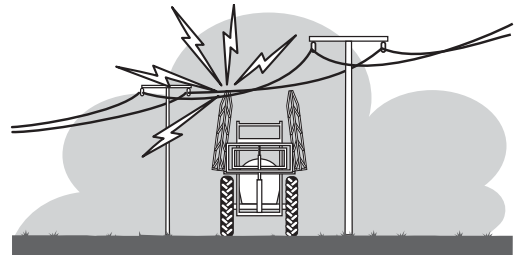

ATTENTION! A label (HARDI® item no. 10533003) is located on the sprayer's drawbar. This label must be visible to the operator when hooking up the sprayer.



ATTENTION! Only unfold and fold the boom on level ground.

Operating the Grip

The buttons on the grip in the tractor control the following sprayer functions in the field:

- A. Status light for power ON/OFF.

The light must be ON.

- B. Boom tilt up/down - left boom side.

Adjust the boom height individually for the right and left boom side if the terrain is hilly.

- C. Boom tilt up/down - right boom side.

- D. Not used.

- E. Not used.

- F. Main ON/OFF for spraying.

Turn it ON for spraying, OFF to stop spraying.

- G. Boom height up.

Aim for a height of 20 in. (50 cm) above the crop when spraying.

- H. Boom height down.

- I. Boom sections spraying ON/OFF.

Switch pushed up is OFF; down is ON.

- J. Presets 1 and 2 for the TWIN air system - the selected air angle and air volume during spraying.

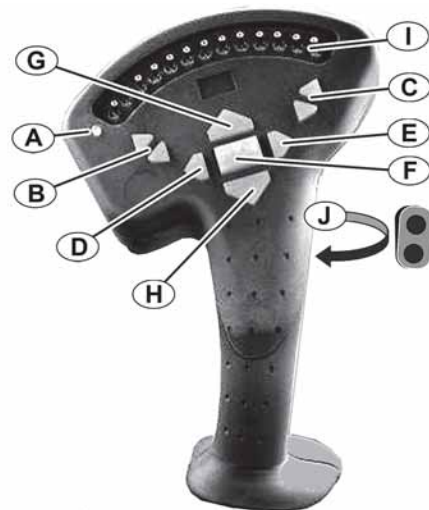

Maneuvering of the Boom

Applicable for HC 6500 / HC 8600 / HC 9600 / ISOBUS.



WARNING! The center lock automatically turns ON when pressing one of the folding buttons. Boom folding is not possible if the center is unlocked. A manual override of the center lock is possible by activating switches 1 or 2 on the SetBox.







WARNING! The folding functions must only be operated when the sprayer is stationary!
For a 120' (36 m) boom, the NORAC Boom Height Control is not to be used together with a 1/2-folded boom. Failure to comply with these warnings can damage the boom.





ATTENTION! The boom can not be operated with the tractor's hydraulic levers.

How To Unfold the Boom

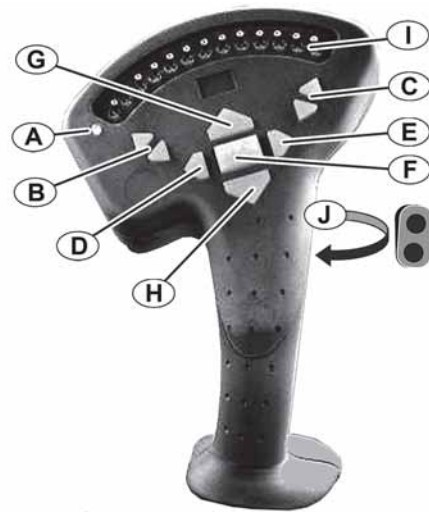
1. Press Grip button (G) to lift the boom clear of the transport brackets. This takes approximately 3 seconds.
2. The symbol  is shown on the display.
If not, press SetBox button  (2) for 1 second to lock the center.
3. Press SetBox button (6) to unfold the inner sections completely.
Press SetBox buttons (4) or (8) to unfold the outer sections completely.
4. Press Grip button (H) to lower the boom to the correct working height.
5. Unlock the center by pressing SetBox button  (1) for 1 second.
The symbol  is now shown on the display.



How To Fold the Boom

1. If the SafeTrack function is installed, press SetBox button (9) to lock the sprayer tracking. The sprayer will now center-align.
2. Lock the center by pressing SetBox button  (2) for 1 second.
The symbol  is shown on the display.
3. Press Grip buttons (B) or (C) to set the boom tilt to horizontal or a little above horizontal (positive tilt).
For a 120' (36 m) boom: Folding is not possible while the boom is in negative tilt position, as this can cause damages to boom! Set the boom tilt as described above.
4. Press Grip button (G) to raise the boom to the highest possible position.
5. Press SetBox buttons (3) or (7) to fold the outer sections completely.
Press SetBox button (5) to fold the inner sections completely.
6. Press Grip button (H) to lower the boom, until it is resting in the ParaLift locks.
7. Press Grip buttons (B) and (C) to lower the left and right boom wings until they are resting in the transport brackets.

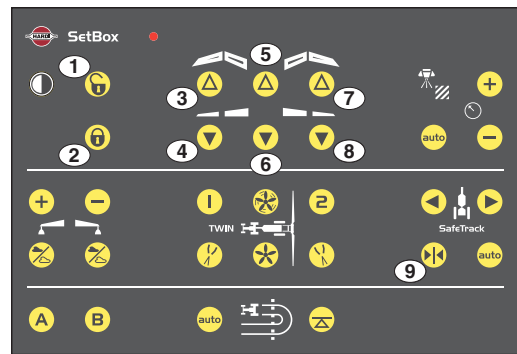







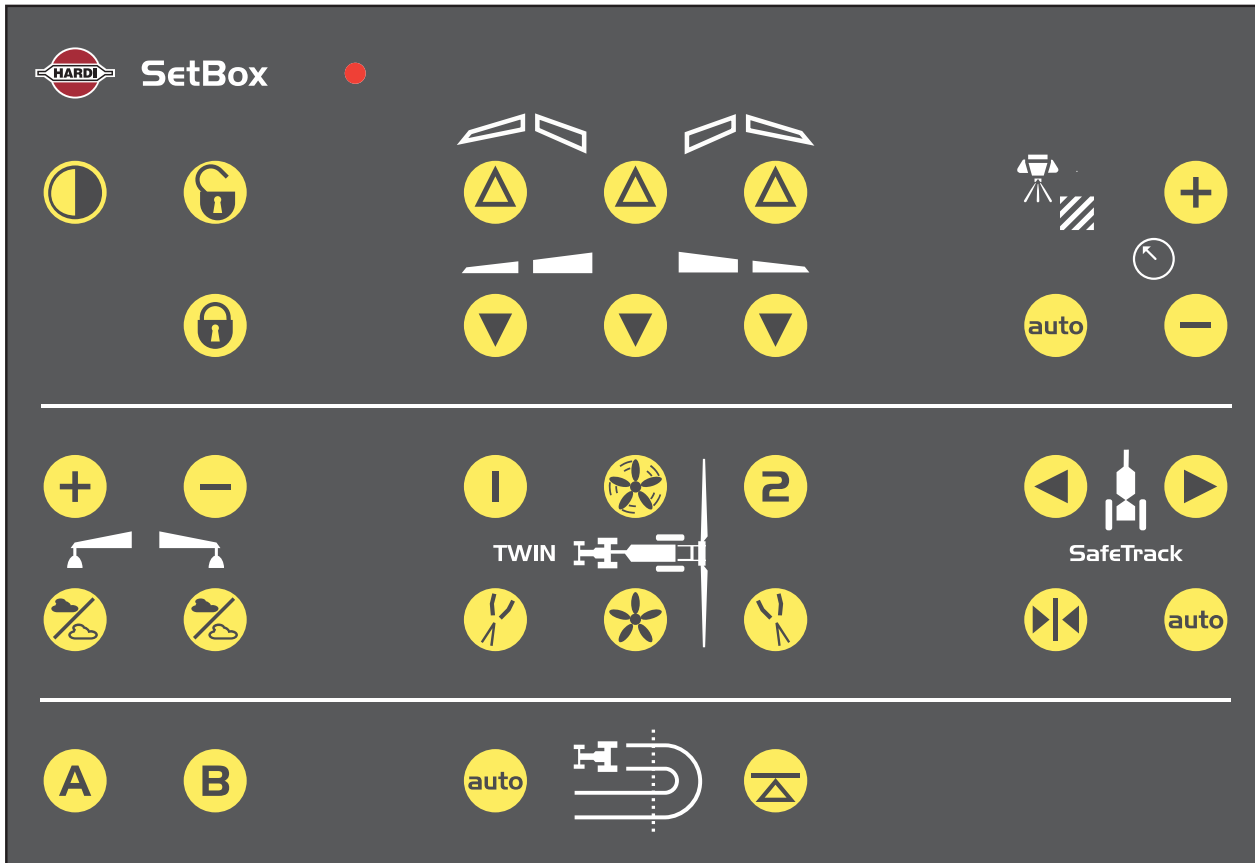

5 - Operation

Operating the Control Unit While Spraying

The buttons on the SetBox in the tractor control the following sprayer functions:



| | |
|---|--|
|  | <p>Status for Power ON/OFF. Power ON: A red LED light is lit. If the light is flashing, an error has occurred in the system.</p> |
|  | <p>Power ON/OFF.</p> |
|  | <p>Spray pressure: Automatic regulation. The regulation valve controls the main spray pressure by default, when the controller is ON. Keep the automatic regulation during normal spraying. The auto mode is ON by default when the controller is turned ON.</p> |
|  | <p>Spray pressure: Manual regulation of spray pressure, up/down. During normal spraying, these buttons should not be used, as the regulation valve does this automatically.</p> |
|  | <p>Foam marker (if installed by the user): Volume regulation up/down (+/-). Foam marking ON/OFF for left or right side.</p> |

| | |
|---|--|
|  | <p>Settings for TWIN air system:</p> <p>Watch the controller display when pressing the buttons.</p> <p>The current air angle is shown as a percentage 0 - 100 %.</p> <p>0 - 49 %: The air system is angled forwards (0 % = 40°).</p> <p>50 %: The air system is in default position with the spray nozzles pointing vertically downwards.</p> <p>51 - 100 %: The air system is angled backwards (100 % = 30°).</p> <p>The current air speed is shown as a percentage 0 - 100 % and/or as revolutions (rpm) for the blower impeller. A value of 100 % equals 3100 rpm for the blower, if the tractor's PTO speed is set at 1000 rpm.</p> <p>A lower PTO speed = a lower blower speed.</p> <p>One short press on the button changes the current value in steps of approx. 5 %.</p> <p>Holding the button will make a greater and stepless change.</p> <p>Button lower left: Adjust the air angle forwards.</p> <p>Button lower right: Adjust the air angle backwards.</p> <p>Button middle top: Increase air speed.</p> <p>Button middle bottom: Decrease air speed. If you spray with the boom 1/2-folded, reduce the air speed with 25 % to obtain the same performance (air speed at nozzles) as for a fully unfolded boom.</p> <p>Press the buttons 1 or 2 to use preset values for air speed and angle. Changing between 1 and 2 is usually done while turning at headlands to spray in the opposite direction. To save a new setting, adjust the air speed and angle, and press 1 or 2 for at least 8 seconds, until the controller display signals the change (if you press the button for less than 8 seconds, the previous saved setting will be in use).</p> |
|  | <p>SafeTrack:</p> <p>This is mainly used when making turns in the field.</p> <p>Press "auto" for automatic adjustment of the sprayer tracking, making it follow the tracks of the tractor's rear wheels.</p> <p>Press left or right arrow to manually adjust the sprayer tracking.</p> <p>Press double arrow to lock the sprayer tracking (the hydraulics will adjust the sprayer to its center position, and a mechanical lock will be activated at the rear). This is always done before folding of the boom.</p> |
|  | <p>Optional functions, A or B.</p> <p>E.g. for night spraying light on the boom:</p> <p>A: Turn lights on; B: Turn lights off.</p> <p>If traffic lights are installed, the work lights will only work, when the traffic lights are turned on.</p> |
|  | <p>Press "auto" to use an optional function.</p> |



NOTE! Check the current application rate on the display, or see the instruction book for the spray controller for more information.

Night Spraying Light

The night spraying light is activated on the controller box in the tractor. Press the A and B switches in the lower left corner. If traffic lights are fitted, the work lights will only work when the traffic light is on.

5 - Operation

Indicator for Angling of TWIN Air System

On the spray boom, an indicator for the current angle is placed facing the tractor.

Looking from the tractor:

- If the black indicator points to the middle of the scale, the air system is in default position = no angling.
- If the indicator points to the left (A), the air system is angled forwards.
- If the indicator points to the right (B), the air system is angled backwards.

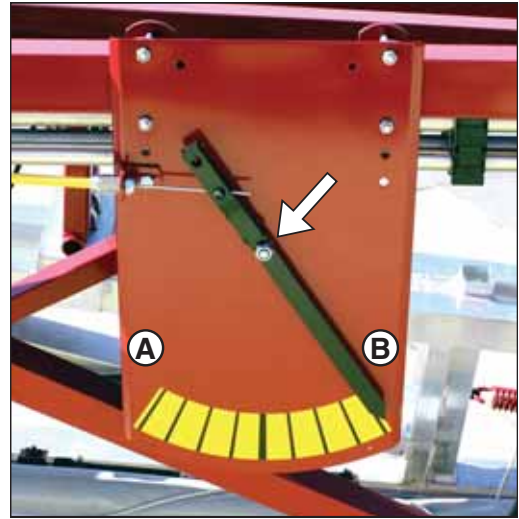

Steering

Driving Technique for SafeTrack

A steered trailer using SafeTrack behaves differently than a standard trailer. In steering position, the sprayer's center of gravity is displaced more outwardly compared to the center line of a standard trailer.

A steered trailer has a decreased stability when turning, especially when turning on hillsides (B).

To prevent overbalancing, pay attention to these guidelines:

- Avoid sudden tight turns.
- Slow down before entering a curve or turning. Drive with a constant, low speed during the turn.
- Never slow down too fast, never brake heavily and never stop suddenly in a curve, or when turning on a hillside, when the sprayer is articulated.
- Be careful when turning on uneven ground.
- Set the track width (A) as wide as possible.
- The proper function of the hydraulic system is essential to obtain good stability.
- A filled Rinsing Tank will significantly increase the stability.

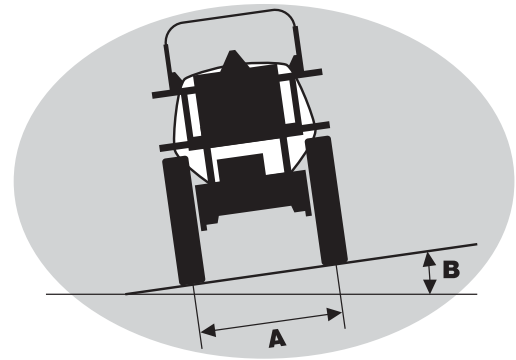

DANGER! No persons are allowed in the operation area of the sprayer when steering is unlocked!



WARNING! Never articulate steering when the boom is in transport position.

Speed Limit

The SafeTrack is default limited to a driving speed of 11mph (18 km/h).

Driving in "Auto" with SafeTrack will trigger an overspeed alarm, and the steering will automatically be locked.

5 - Operation

Liquid System

Filling/Washing Location Requirements

When filling the sprayer with chemicals and water, it is important to avoid spot contamination by spraying chemicals in order to protect the subsoil water resources.

At a Dedicated Filling Site

If the sprayer is always filled on the same location, a special filling/washing location should be established. This should have a hard, liquid-impenetrable surface (e.g. concrete) securing against seepage, together with edges securing against run-off to the surrounding areas. The location should be drained to an adequate receptacle (e.g. slurry tank or similar).

Any spillage or washings should be retained and diluted in order to be distributed in a larger area. This is to ensure minimal environmental impact and avoid build-up of larger chemical concentrations at one spot.

If no other requirements of distances exist, the following general recommendation of distance can be used. Filling location must be no closer than:

1. 50 yards (meters) from public water supplies for drinking purposes, and
2. 25 yards (meters) from non-public water supplies for drinking purposes and from treatment sumps and cesspools of drainage systems, and
3. 50 yards (meters) from surface water (watercourses, lakes and coastal waters) and from nature reserves.

In the Field

Alternatively the sprayer can be filled in the field, where the spraying is to take place. If so, choose a different location for each refilling.

If no other requirements of distances exist, the filling should not take place closer than:

1. 300 yards (meters) from public or non-public water supplies for drinking purposes, and
2. 50 yards (meters) from surface water (watercourses, lakes and coastal waters), treatment sumps, cesspools of drainage systems, and nature reserves.



ATTENTION! Legislation and requirements vary. Always follow local legislation in force at any time.



ATTENTION! It is the responsibility of the sprayer owner/operator to comply with all relevant legislation. HARDI® cannot undertake any responsibilities for incorrect operation and use.

Filling of Water

The tank should normally be filled 1/3 with water before adding chemicals. Always follow the instructions given on the chemical container!



WARNING! If the sprayer is put aside with liquid in the main tank, all manifold valves must be closed.

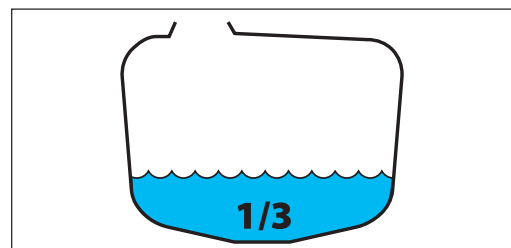

Filling Through Tank Lid

Water is filled into the main tank by removing the tank lid located at the top of the sprayer, which is accessible from the platform. It is recommended to use water as clean as possible for spraying purposes. Always fill water through the strainer basket to prevent foreign particles from entering the tank. An overhead tank can be used in order to obtain high filling capacity.



WARNING! Do not let the filling hose enter the tank. Keep it outside the tank, pointing towards the filling hole. If the hose is led into the tank and the water pressure drops at the water supply, chemicals may be siphoned back and contaminate the water supply lines and source.



The water supply line should be provided with a check valve as additional safety precaution. Follow local legislation in force at any time.



The water supply should be provided with a water meter to avoid spillage by overfilling. Follow local legislation in force at any time.

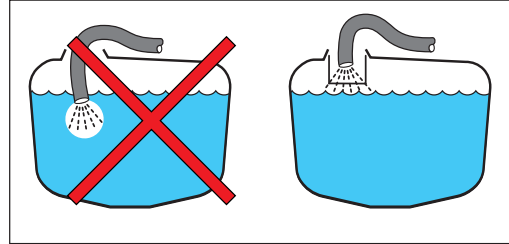

Main Tank Quick Fill

The main tank is filled via the 3" quick coupler located behind the TurboFiller:

1. Remove plug from Quick Fill valve and connect filling hose from water supply.
2. Open the Quick Fill valve and fill tank to desired level.
3. Keep an eye on the main tank level indicator in order not to overfill the tank.
4. Close the Quick Fill valve and remove the filling hose.
5. Replace the plug to the Quick Fill coupler when filling is complete.

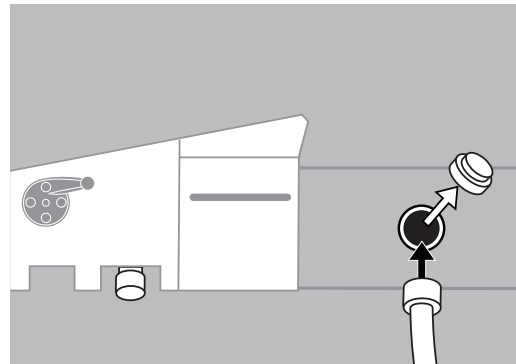

Filling of Rinsing Tank

The rinsing tank is filled via the 2" quick coupler at the manifold system:

1. Remove plug from Quick Fill valve and connect filling hose from water supply.
2. Open the Quick Fill valve and fill tank to desired level.
3. Keep an eye on the level indicator in order not to overfill the tank.
4. Close the Quick Fill valve and remove the filling hose.
5. Replace the plug to the Quick Fill coupler when filling is complete.

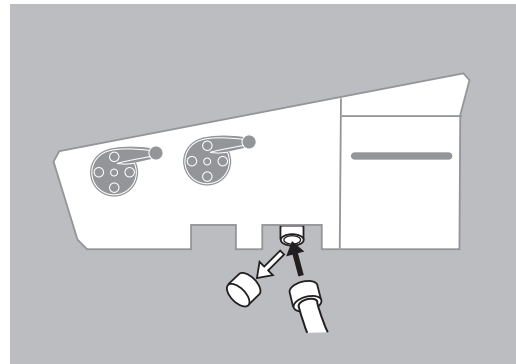

Capacity: approximately 130 gallons (500 liters).



ATTENTION! Only fill rinsing tank with clean water! To avoid algae developing in the rinsing tank, always drain the rinsing tank if the sprayer is not in use for a long period of time.



ATTENTION! For cleaning purposes etc. the rinsing tank is also accessible via the tank lid on top of the tank.

5 - Operation

Filling of Clean Water Tank

To fill the clean water tank:

1. Remove the tank lid.
2. Fill with clean water.
3. Replace the tank lid.

For use of water:

- Turn the lever to open the ball valve. (A)

The water from this tank is for hand washing, cleaning of clogged nozzles etc.

Capacity: approximately 5 gallons (20 liters).



WARNING! Although the clean water tank is only filled with clean water, this water must NOT be used for drinking.



ATTENTION! Only fill this tank with clean water! To avoid algae developing in the clean water tank, always drain this tank if the sprayer is not in use for a longer period of time.



Safety Precautions - Crop Protection Chemicals



Always be careful when working with crop protection chemicals!



WARNING! Always wear proper protective clothing before handling chemicals!

Personal protection

Depending on chemical type, protective gear/equipment should be worn to avoid contact with the chemicals, such as:

- Gloves
- Waterproof boots
- Headgear
- Respirator
- Safety goggles
- Chemical resistant overall



WARNING! Protective clothing/equipment should be used when preparing the spray liquid, during the spray job and when cleaning the sprayer. Follow the chemical manufacturer's instructions given on the chemical label and/or local legislation.



WARNING! It is always advisable to have clean water available, especially when filling the sprayer with chemicals.



WARNING! Always clean the sprayer carefully and immediately after use.



WARNING! Only mix chemicals in the tank according to directions given by the chemical manufacturer.



WARNING! Always clean the sprayer before changing to another chemical.

Filling chemicals through tank lid



ATTENTION! We recommend using the TurboFiller when adding chemicals to the sprayer.

The chemicals are filled through the tank lid - Note instructions on the chemical container!



WARNING! Be careful not to slip or splash chemicals when carrying chemicals up to the tank lid!

1. Make sure the spray control unit is switched off.
2. Turn the suction SmartValve handle to "Suction from main tank". Turn the pressure SmartValve handle to an unused function. Turn the Agitation valve to "Agitation".
3. Engage the pump and set P.T.O. revolutions to 1000 rpm.
4. Add the chemicals through the main tank hole.
5. When the spray liquid is well mixed, leave the suction SmartValve handle turned to "Suction from Main tank" and turn pressure SmartValve handle to "Spraying" position. Keep P.T.O. engaged so the spray liquid is continuously agitated until it has been sprayed on the crop.

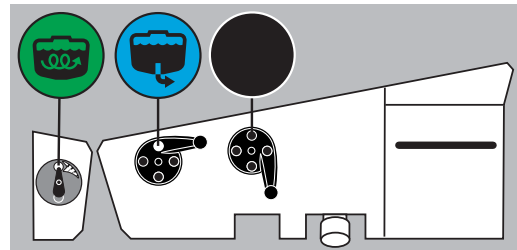

5 - Operation

Operating the TurboFiller

The TurboFiller is used to add the chemicals to be mixed with water in the main tank.

Capacity: approximately 9.25 gal. (35 liters).

Before Use

- Push lever (A) to unlock the position of the TurboFiller.
- Grab the handle and pull the TurboFiller towards you.
- Lower the TurboFiller until it clicks into the locked position.
- Unlock the latch on the left and open lid (B) fully.
- Place chemicals for the upcoming spray job here, ready to be filled into the TurboFiller.



After Use

- Clean the inside of the TurboFiller with the spray wand to remove chemical residues.
- Place the spray wand in its storage position (C).
- Close the lid on top of the TurboFiller and lock it on the left side.
- Push lever (A) to unlock.
- Grab the handle and lift the TurboFiller upwards.
- Push the TurboFiller back in storage position, until it locks.



ATTENTION! When unlocking the TurboFiller, always keep a hand on the handle to avoid abrupt movement of the TurboFiller!



On the next page is a short description on how to operate the valves by using the levers on the side of the TurboFiller.

For more details, see the following sections in this Instruction Book about the procedure for operating the TurboFiller while filling chemicals.

TurboFiller Suction Valve

The valve is used simultaneously with the TurboFiller. The valve has 2 settings: Continuously open or spring-loaded normally closed.

Open the valve by lifting the lever up when chemicals are to be filled into the TurboFiller and transferred to main tank.

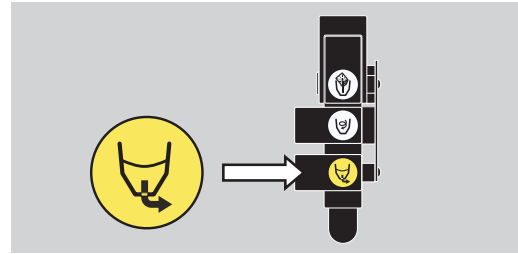

TurboDeflector Valve

This TurboDeflector valve activates the vortex flushing of the TurboFiller. Lift the lever to lock it in open position for continuous liquid rotation in the hopper.

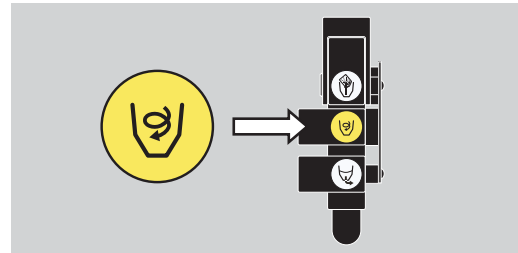

Chemical Container Rinsing Lever

The upper lever is used for two purposes.

1. When the TurboFiller lid is open:
For rinsing empty containers. Place the container over the rotating flushing nozzle in the middle of the TurboFiller to rinse the inside of the container.
2. When the TurboFiller lid is closed:
Use the lever to rinse the hopper after the filling of chemicals is completed.

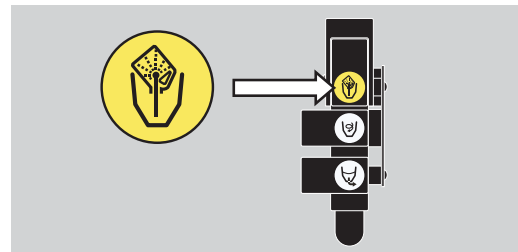

DANGER! Do not activate this lever unless the multi-hole nozzle is covered by a container, or the TurboFiller lid is closed, to avoid spray liquid hitting the operator! Risk of injuries and spillage on the ground.

5 - Operation

Filling Liquid Chemicals Using the TurboFiller

1. Fill the main tank at least 1/3 with water (unless otherwise stated on the chemical container label).
2. Turn the suction SmartValve handle to "suction from Main tank". Turn the pressure SmartValve handle to "TurboFiller". Adjust Agitation valve to desired setting.

 ATTENTION! For increased suction from the TurboFiller, the Agitation Valve can be kept closed.

3. Engage the pump and set P.T.O. revolutions to 1000 rpm.
4. Open TurboFiller lid. Measure the correct quantity of chemical and fill it into the hopper.

 DANGER! Always wear face shield and other appropriate personal safety equipment when filling chemicals.

 ATTENTION! The scale in the hopper can only be used if the sprayer is parked on level ground! It is recommended to use a measuring jug for best accuracy.

5. Engage the hopper transfer device by opening the TurboFiller suction valve to transfer chemicals to the main tank. The TurboFiller suction valve must be open for at least 20 seconds after the chemical is no longer visible in the hopper in order to completely empty the transfer hoses into the main tank.

 DANGER! If the TurboFiller and the transfer hoses are not completely emptied, there is a risk of chemicals being siphoned out of the main tank!

6. If the chemical container is empty, it can be rinsed by the Chemical Container Cleaning device. Place the container over the multi-hole nozzle and push the container cleaning lever.

 DANGER! In order to avoid spray liquid hitting the operator, do not press lever unless the multi-hole nozzle is covered by a container as spray liquid may otherwise hit the operator!

 ATTENTION! Rinsing device uses spray liquid to rinse containers for concentrated chemicals. Always rinse the chemical containers with clean water several times until they are clean before disposal.

7. Flush the TurboFiller with clean water from the Rinsing tank. The TurboFiller suction valve must be open for at least 20 seconds after the rinse water is no longer visible in the hopper in order to completely empty the transfer hoses into the main tank.

 ATTENTION! If not flushed with clean water, the hopper rinsing device uses spray liquid for rinsing the hopper! Cleaning the TurboFiller must always be done when the spray job is ended and together with the entire sprayer. A cleaning after the last filling and before spraying the last tankful does not ensure a clean TurboFiller!

8. Close TurboFiller suction valve when the hopper has been rinsed and close the lid.
9. If closed, turn the Agitation Valve to "Agitation".

 ATTENTION! If foaming is a problem, turn down the agitation.

10. When the spray liquid is well agitated, turn handle of the pressure SmartValve to "Spraying" position. Keep P.T.O. engaged so the spray liquid is continuously agitated until it has been sprayed on the crop.

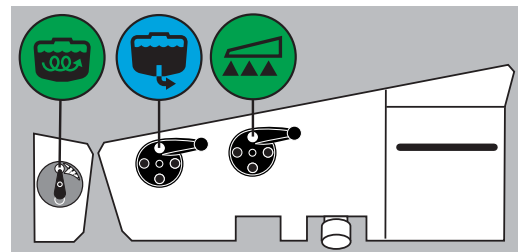
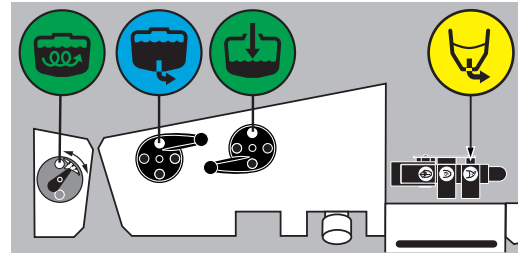

Filling Powder Chemicals Using the TurboFiller

1. Fill the main tank at least 1/2 with water (unless otherwise stated on the chemical container label).
2. Turn the suction SmartValve handle to "Suction from Main tank". Turn the pressure SmartValve handle to "TurboFiller". Adjust Agitation valve to desired setting.



ATTENTION! For increased suction from the TurboFiller the Agitation Valve can be kept closed.

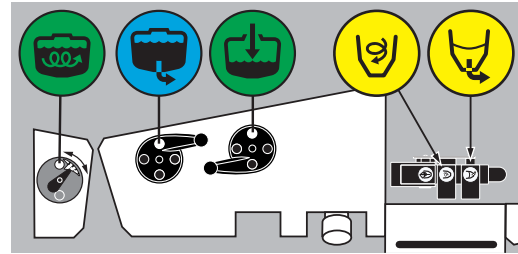

3. Engage the pump and set P.T.O. revolutions to 1000 rpm.
4. Open TurboFiller lid. Open TurboDeflector valve and TurboFiller suction valve.
5. Measure the correct quantity of chemical and sprinkle it into the hopper as fast as the transfer device can flush it down. The TurboFiller suction valve must be open for at least 20 seconds after the chemical is no longer visible in the hopper in order to completely empty the transfer hoses into the main tank.



DANGER! If the TurboFiller and the transfer hoses are not completely emptied, there are risk of chemicals being siphoned out of the main tank!



DANGER! Always wear face shield and other appropriate personal safety equipment when filling chemicals.

6. If the chemical container is empty, it can be rinsed by the Chemical Container Cleaning device. Place the container over the multi-hole nozzle and push the container cleaning lever.



DANGER! In order to avoid spray liquid hitting the operator, do not press lever unless the multi-hole nozzle is covered by a container as spray liquid may otherwise hit the operator.



ATTENTION! Rinsing device uses spray liquid to rinse containers for concentrated chemicals. Always rinse the chemical containers with clean water several times until they are clean before disposal.

7. Flush the TurboFiller with clean water from the Rinsing tank. The TurboFiller suction valve must be open for at least 20 seconds after the rinse water is no longer visible in the hopper in order to completely empty the transfer hoses into the main tank.



ATTENTION! If not flushed with clean water, the hopper rinsing device uses spray liquid for rinsing the hopper! Cleaning the TurboFiller must always be done when the spray job is ended and together with the entire sprayer - cleaning after the last filling and before spraying the last tankful does not ensure a clean TurboFiller!

8. Close TurboFiller suction valve when the hopper has been rinsed and close the lid.
9. If closed, turn the Agitation Valve to "Agitation".

10. When the spray liquid is well agitated, turn handle of the pressure SmartValve to "Spraying" position. Keep P.T.O. engaged so the spray liquid is continuously agitated until it has been sprayed on the crop.

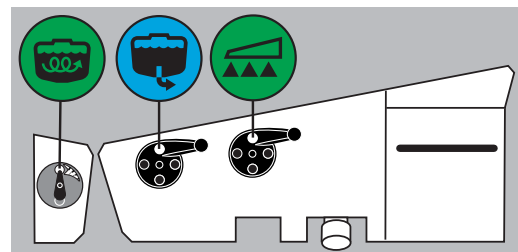

5 - Operation

Agitation Before Resuming a Spray Job

If a spray job has been interrupted for a while, severe sedimentation may occur depending on the chemicals being used. Before resuming the spray job, it might be necessary to agitate sedimented material first.

1. Turn the handle at the suction valve to "Suction from main tank". Turn the pressure SmartValve handle to an unused function and turn the Agitation valve to "Agitation".
2. Engage the pump and set P.T.O. revolutions to 1000 rpm.
3. Agitation will start and should be continued for at least 10 minutes.
4. Once the chemicals are mixed, spraying can resume. Turn pressure SmartValve to "Spraying" and start spraying.

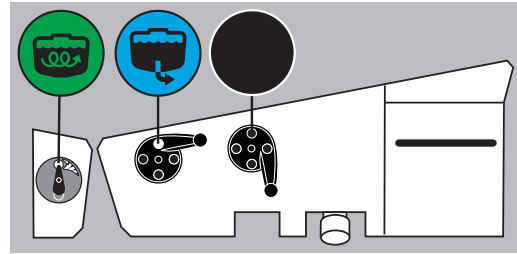

TurboFiller Rinsing



NOTE! It is important to use clean water from the rinsing tank.

Rinse the TurboFiller and chemical containers as follows:

Cleaning Empty Containers - TurboFiller Lid is Open

1. Put container over the rotating flushing nozzle in the middle of the TurboFiller so that the nozzle is inside the container.
2. Simultaneously press the Chemical Container Cleaning lever and the TurboFiller suction valve. This rinses the chemical container with the flushing nozzle while the rinsing liquid is emptied out of the TurboFiller.

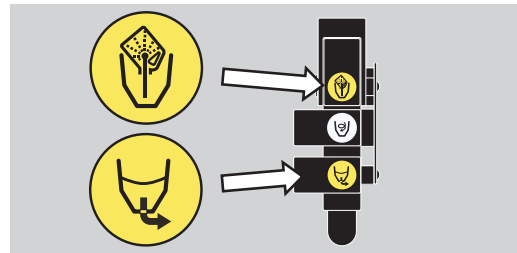

TurboFiller Rinsing - TurboFiller Lid is Closed

1. Close TurboFiller lid.
2. Turn the suction SmartValve to "Rinsing tank".
3. Open the Turbo Deflector Valve  for 1 minute to get plenty of clean water through the hoses.
4. Simultaneously press the Chemical Container Cleaning lever and the TurboFiller suction valve. This rinses the hopper with the flushing nozzle while the rinsing liquid is emptied out of the TurboFiller.
5. Rinse the hopper for 30-40 seconds.
6. Open the lid to inspect if the TurboFiller is empty. If not, close the lid again and press the TurboFiller suction valve, until the TurboFiller is empty.
7. After the last flushing, the TurboFiller suction valve must be open for at least 20 seconds after the rinse water is no longer visible in the hopper in order to completely empty the transfer hoses into the main tank.



ATTENTION! The TurboFiller needs to be cleaned thoroughly after finishing spraying. This is to ensure that it is clean before spraying other crops that may be sensitive to the chemicals just used. See the section "Cleaning" on page 86 for details.

Before Returning to Refill the Sprayer

If the sprayer is to be refilled at the farm or at a fixed filling place without a filling space with hard surface and drain to a closed reservoir, the sprayer should be rinsed before returning to refill.

Dilute the residues of the spraying circuit, and spray it on the crop. Then rinse the sprayer on the outside with the External Cleaning Device before returning to the farm.



WARNING! Always follow local legislation in force at any time.

Parking the Sprayer

To avoid spot contamination, the sprayer should always be parked at either the washing/filling location or under roof.

This prevents rainfall from washing down chemical residues from the sprayer's surfaces.

- Parking at the washing/filling location will retain residues.
- Always park the machine out of reach of children, animals and unauthorized persons.
- Always follow local regulations when parking your sprayer.

Quick Reference - Operation

In the following diagrams handle positions for different options are described.

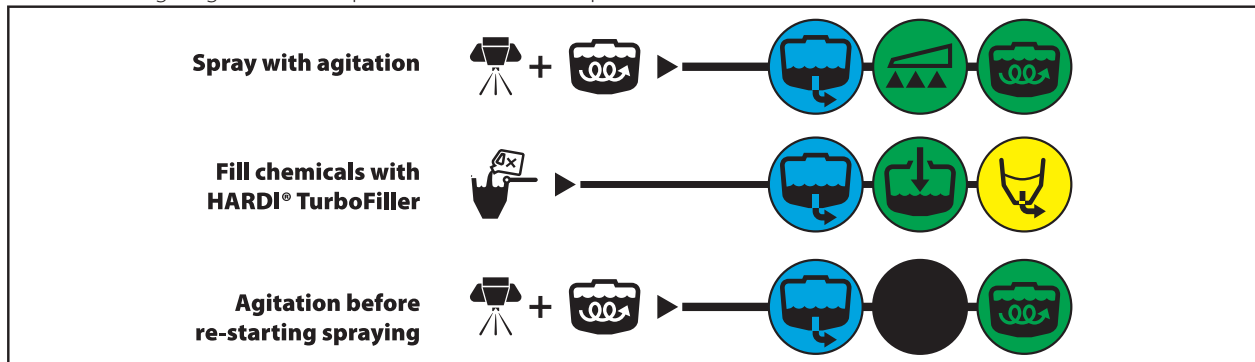

5 - Operation

Cleaning

General Info

In order to derive full benefit from the sprayer for many years, the following service and maintenance program should be followed.



ATTENTION! Always read the individual paragraphs. Read instructions for service/maintenance jobs carefully before starting on the job. If any portion remains unclear or if it requires facilities which are not available, then please leave the job to your HARDI® dealer's workshop for safety reasons.



ATTENTION!

Clean sprayers are safe sprayers.

Clean sprayers are ready for action.

Clean sprayers cannot be damaged by pesticides and their solvents.

Guidelines

- Read the whole chemical label. Take note of any particular instructions regarding recommended protective clothing, deactivating agents, etc. Read the detergent and deactivating agent labels. If cleaning procedures are given, follow them closely.
- Be familiar with local legislation regarding disposal of pesticides washings, mandatory decontamination methods, etc. Contact the appropriate department (e.g. Dept. of Agriculture) if you are in doubt.
- Pesticide washings can usually be sprayed out on the field just sprayed or at a suitable cultivated area. Avoid emptying the washings at the same spot every time and keep sufficient distance to the water environment. You must prevent seepage or runoff of residue into streams, water courses, ditches, wells, springs, etc. The washings from the cleaning area must not enter sewers. Alternatively the washings can be retained in an appropriate receptacle, diluted and distributed over a larger cultivated area - see also "Filling/Washing Location Requirements" on page 76.
- Cleaning starts with the calibration, as a well calibrated sprayer will ensure the minimal amount of remaining spray liquid.
- It is good practice to clean the sprayer immediately after use, and thereby render the sprayer safe and ready for the next pesticide application. This also prolongs the life of the components. It is strongly advised to perform an internal cleaning of the sprayer when high concentrations of acids or chloride are present in the active ingredients, or if the spray liquid is corrosive. For the best result, use a cleaning agent suitable for cleaning agricultural sprayers.
- It is sometimes necessary to leave spray liquid in the tank for short periods, e.g. overnight, or until the weather becomes suitable for spraying again. Unauthorized persons, children and animals must not have access to the sprayer under these circumstances.
- If the product applied is corrosive, it is recommended to coat all metal parts of the sprayer before and after use with a suitable rust inhibitor.
- The sprayer must always be parked under roof to avoid rain washing off pesticides as well as build-up of spot contamination in the soil. If parked outside, the sprayer should be parked on the filling/washing location in order to retain possible pesticides.

Quick Reference - Cleaning

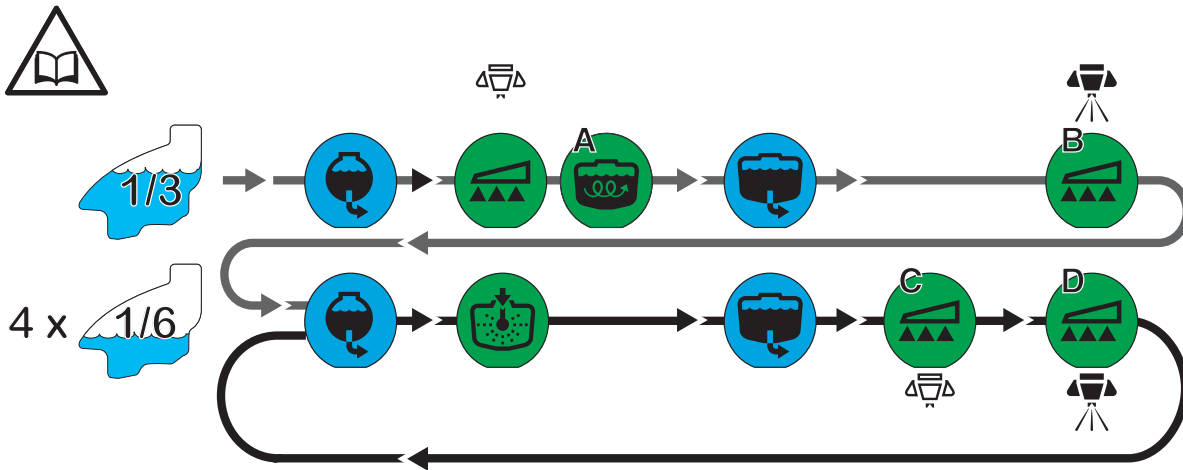

 ATTENTION! Pump speed 560 rpm.

- A. Full agitation.
- B. Spray until air comes out of nozzles. Engage FlexCapacity pump.

When the pressure drops, close the regulation valve by pressing the  button on the SetBox until yellow LED lights on the valve (this can take up to 10 seconds).

Press "auto" to have the system remove pressure spikes automatically before next start-up.

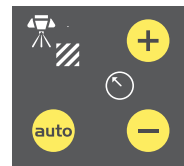





- C. Minimum 45 seconds with nozzles OFF.
- D. Spray until air comes out of nozzles.

5 - Operation

Standard Cleaning



ATTENTION! For cleaning between spray jobs, where crops are not very sensitive towards chemicals just sprayed.

1. Engage the pump with tractor in idle, so that pump speed is as low as possible (approx. 560 rpm).
2. Turn the suction valve to  and the pressure valve to  with all boom sections OFF while transferring approximately 1/3 of the RinseTank contents into the main tank.
It is important to have full agitation for approximately 20 seconds; and then close the agitation valve completely.
3. Turn the suction valve to  with the pressure valve turned to  with all boom sections OFF for approximately 45 seconds.
4. Switch all boom sections ON. Spray until air comes out of nozzles. Engage FlexCapacity pump.

When the pressure drops, close the regulation valve by pressing the  button on the SetBox, until yellow LED lights on the valve (this can take up to 10 seconds).

Press "auto" to have the system remove pressure spikes automatically before next start-up.



Repeat the Following Three Steps 5 Times:

5. Turn the suction valve to  and the pressure valve to  while transferring approximately 1/6 of the RinseTank content into the main tank.
6. Turn the suction valve to  and the pressure valve to  with all sections off for approximately 45 seconds.
7. Switch all boom sections ON. Spray until air comes out of nozzles. Engage FlexCapacity pump.

When the pressure drops, close the regulation valve by pressing the  button on the SetBox, until yellow LED lights on the valve (this can take up to 10 seconds).

Press "auto" to have the system remove pressure spikes automatically before next start-up.



Cleaning and Maintenance of Filters

Clean filters ensure:

- Sprayer components such as valves, diaphragms and operating units are not hindered or damaged during operation.
- Nozzle clogging do not occur while spraying.
- Long life of the pump. A blocked suction filter will result in pump cavitation. The main filter protecting sprayer components is the suction filter. Check it regularly.

Use of Cleaning Agent

It is recommended to use an appropriate cleaning agent suitable for cleaning agricultural sprayers.

- Cleaning agents containing a suitable lube or conditioner are recommended.
- If for some reasons this is not available, and triple ammonia water is used instead, it is important to rinse the liquid system immediately after, and add some lubricant to the rinsing water to prevent ball valves etc. seizing up.
- Use of automotive antifreeze/radiator coolant (ethylene glycol) will protect valves and seals from drying or seizing up.

Use of Rinsing Tank and Rinsing Nozzles

The integrated rinsing tank can be used for three different purposes:

- A. Full internal rinsing (In-field diluting before cleaning or when using same chemicals again soon).
- B. External cleaning of the sprayer (can only be carried out after completion of "A.").
- C. Rinsing the liquid system without diluting main tank contents (Rinsing when main tank is not empty).
- D. Full internal cleaning (before storage or when switching chemicals).



ATTENTION! The cleaning procedures stated requires the TurboFiller to be cleaned beforehand (directly after the last chemical filling). If the TurboFiller has not been cleaned, it must be cleaned before performing cleaning procedures A, B, C or D. See "TurboFiller Rinsing" on page 84.

Note that cleaning the TurboFiller will then use water from the rinsing tank, thus reducing the available quantity for the cleaning procedures.



ATTENTION! Do NOT fill any cleaning agents into the rinsing tank. If cleaning agents are to be used, they should be filled into the main tank, e. g. via the TurboFiller.

A. Full Internal Rinsing

In-field diluting of remaining spray liquid residues in the spraying circuit for spraying the liquid in the field, before cleaning the sprayer.



NOTE! This rinsing is adequate/sufficient when the sprayer is going to be used again shortly (e.g. next day) in same or similar crops (No risk of cross contamination and subsequent crop damages).



WARNING! If the next crop to be sprayed is sensitive to the latest chemical used, then a full cleaning should be carried out. See "D. Full Internal Cleaning (Soak Wash)" on page 92.



WARNING! Never clean the sprayer if there are risks of contamination of surface or underground water! Choose a different spot for cleaning every time to avoid spot contamination to build up.

This rinsing procedure will rinse the liquid system and main tank as follows:

1. Empty the sprayer as much as possible. Close the agitation valve (no agitation). Allow the pump to run for at least 1 minute after the liquid has stopped coming out of the nozzles to ensure that all relevant liquid has been expelled.
2. Shut off all nozzles with the main ON/OFF button on the grip.
3. Turn suction SmartValve to "Rinsing tank" and pressure SmartValve to "Spraying". Set agitation valve to "Full agitation".
4. Engage and set the pump at approximately 560 rpm.
5. Use 1/3 (approximately 40 gal or 150 l) of the rinsing tank content at this valve setting.
6. Close the agitation valve and turn the pressure SmartValve to "TurboFiller" for at least 3 seconds without activating the Turbofiller to burst and flush the safety valve. The TurboFiller is not flushed by this operation.
7. Turn suction SmartValve to "Main tank". Engage the auxiliary pump (FlexCapacity configurations only). Set the spraying pressure at 45-75 psi (3-5 bar). If the pressure is set outside this range, the rinsing result may be insufficient.
8. Allow the rinsing water in the main tank to circulate for minimum 45 seconds with the nozzles shut to flush the return lines from boom to tank.
9. Open all nozzles and spray the rinsing water from the main tank through the nozzles while driving in the field. Choose a different location each time to distribute the rinsing water over larger areas. Continue until all fluid is expelled from the boom tubes and nozzles - this may take several minutes after the spray fan has collapsed.
10. Shut off all nozzles by the main ON/OFF button on the grip.
11. Turn the suction SmartValve to "Rinsing tank" and the pressure SmartValve on "Internal tank rinsing". Use another 1/6 (approximately 20 gal or 75 l) for this. The tank strainer should be removed to avoid shading the rinsing nozzle.
12. Turn the suction SmartValve to "Main tank" and the pressure SmartValve to "Spraying". With the nozzles shut, allow the liquid to circulate for minimum 30 seconds to flush the return lines from boom to tank.

5 - Operation

13. Open all nozzles by the main ON/OFF switch and spray the rinsing water from the main tank through the nozzles until all liquid is expelled from the boom tubes and nozzles.
14. Repeat step 10-13 another 3 times using 1/6 (approximately 20 gal or 75 l) of the rinsing tank contents in each of the 3 sequences until the rinsing tank is empty.
15. Shut off the nozzles at the main ON/OFF button once the rinsing process is complete.

B: External cleaning

This procedure is used to clean the sprayer on the outside in the field as required with the External Cleaning Device.



NOTE! Before attempting an external rinsing, make sure the main tank is rinsed ("A.") and empty! Any liquid left in the main tank will be mixed with the clean water for external rinsing!



NOTE! Approximately 25 gal (100 l) of clean water in the rinsing tank will allow approximately 15 minutes of rinsing (Cleaning nozzle consumption is 1.6 gal/min or 6 liters per minute at 145 psi or 10 bar pressure).



WARNING! Never clean the sprayer if there are risks of contamination of surface or underground water! Choose a different spot for cleaning every time to avoid spot contamination building up.

1. Engage pump at approximately 560 rpm.
2. Turn suction SmartValve to "Rinsing tank" and pressure SmartValve to "Internal Tank Rinsing".

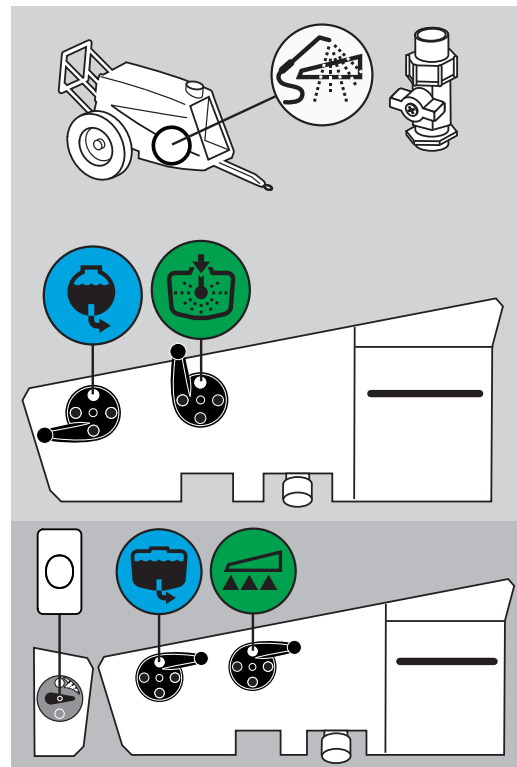

3. When enough water from the rinsing tank is transferred, turn suction SmartValve to main tank.
4. Turn pressure SmartValve to "Spraying" position and close the agitation valve. Adjust the pressure manually to approximately 145 psi (10 bar).

5. Open the ChemLocker cover. The cleaning wand is located in the holder (C).
6. Pull out the hose from the reel.
7. Turn the ball valve to position (A) to open.
8. Wash the sprayer with the cleaning wand.
9. When finished, disengage the pump and close the ball valve again by turning it to position (B).
10. Retract the hose and put the spray wand back in the holder (C).



ATTENTION! Do not let go of the hose. Gently restrict the roll-in of the hose.



ATTENTION! If the sprayer is cleaned with a high pressure cleaner, lubrication of the entire machine is recommended afterwards.

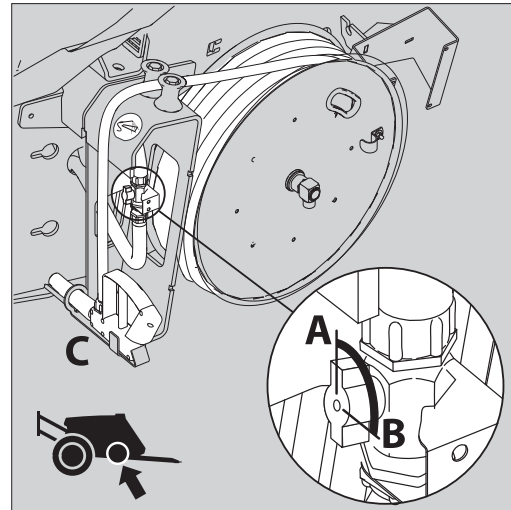

C: Rinsing When Main Tank Is Not Empty

This procedure is used to rinse the pump, operating unit, spray lines, etc. in case of stopping the spray job before the main tank is empty (e.g. at the beginning of rain, etc.).

Cleaning of the liquid system:

1. Turn Suction SmartValve to "Rinsing tank". (Keep pressure SmartValve in "Spraying"-position).



NOTE! The main ON/OFF function on the grip must be ON. Closing the main ON/OFF will transfer the rinse water back to the main tank!

2. Close agitation valve (no agitation).
3. Turn off the CycloneFilter Boost Valve to avoid dilution of main tank content.
4. Engage and set the pump to approximately 560 rpm and spray water from the rinsing tank into the field, until all boom pipes and nozzles are flushed with clean water.
5. Turn off the pump when rinsing is finished.



ATTENTION! It is advisable to increase the forward speed (double if possible) and reduce the spray pressure to 20 psi (1.5 bar) when spraying diluted spray liquid in the field just sprayed.



ATTENTION! If a cleaning procedure is given on the chemical label, follow it closely.

5 - Operation

D. Full Internal Cleaning (Soak Wash)



ATTENTION! This cleaning procedure is always used when one or more of these situations occur:

- The next crop to be sprayed is at risk of being damaged by the chemical just used.
- The sprayer is not going to be used right away for the same chemical or crop.
- Before any repair or maintenance job is going to be carried out on the sprayer.



ATTENTION! Washing the sprayer between jobs with incompatible crops must be done according to instructions from the chemical manufacturer. Use a commonly used cleaning agent. If your chemical prescribes a different cleaning agent and/or another cleaning procedure, you must follow that.

Procedure for Washing with a Cleaning Agent

1. Rinse the sprayer in the field (see the section "A. Full Internal Rinsing" on page 89).
2. Drive to the filling location.
3. Prepare sprayer for cleaning. Fill water in the main tank to 10% of its capacity. Fill the rinsing tank completely. This water is later used for rinsing.
4. Add the cleaning agent to the main tank by using the TurboFiller. Follow instructions on the label of the cleaning agent.
5. Set suction SmartValve for "Main tank" and pressure SmartValve for "Spraying" (with all nozzles shut off by the main ON/OFF switch on the grip). Set agitation valve for "Full agitation".
6. Engage and set the pump speed at approximately 560 rpm. Engage auxiliary pump (FlexCapacity pump).
7. Allow the liquid to circulate the system for 3 minutes with the nozzles shut to clean the return lines from boom to tank.
8. Close the agitation valve and turn the pressure SmartValve to "TurboFiller" for at least 10 seconds without activating the TurboFiller in order to burst and flush the safety valve.
9. Open the TurboFiller transfer valve and the deflector valve. Allow the liquid to circulate for 3 minutes.
10. Close the lid and activate the container rinsing valve to clean the hopper inside.
11. Shut all three valves on the TurboFiller again.
12. Set the pressure SmartValve for "Spraying".
13. Allow the liquid in the main tank to circulate for minimum 3 minutes with the nozzles shut. This is done to clean the return lines from boom to tank.
14. Set the pressure SmartValve for "Internal tank rinsing". Allow the liquid to circulate for 3 minutes.
15. Spray out water with cleaning agent and chemical residue. Set the spray pressure at 45-75 psi (3-5 bar). Note that the washing water still contains active chemical and choose an appropriate area to spray this out. Alternatively, the washings can be dumped at the filling/washing location and retained in an appropriate receptacle (e.g. slurry tank or similar) - see "Filling/Washing Location Requirements" on page 76. Spot contamination and accumulation must be prevented. Continue to spray until all liquid has exited from the boom pipes and nozzles.
16. Shut off all nozzles with the main ON/OFF switch.
17. Rinse the sprayer again with clean water to rinse out all remaining cleaning agent. See "A. Full Internal Rinsing" on page 89. This prevents the cleaning agent remaining in the fluid system from damaging the next spray chemical filled into the main tank.
18. Include rinsing of the TurboFiller in step 18. Operate all 3 valves during this process.
19. Dismantle all filters (suction, pressure, in-line and nozzle filters) and clean the filter screens using clean water, detergent and a brush.



WARNING! It is the responsibility of the sprayer operator or owner that the sprayer is cleaned sufficiently to prevent contamination of the environment, crop damages and health and safety hazards to the operator and the public. HARDI® cannot be held responsible for any damages or incidents related to insufficient cleaning.



ATTENTION! The rinsing nozzles cannot always guarantee a 100% cleaning of the tank. Clean manually with a high pressure cleaner afterwards, especially if the next crop is sensitive to the chemical just sprayed!

Technical Residue

An amount of spray liquid will inevitably remain in the system. It cannot be sprayed properly on the crop, as the pump takes in air when the tank is just about empty.

This technical residue is defined as the remaining amount of liquid in the system when the first clear pressure drop appears on the pressure gauge. See "Technical Residue" on page 152.

The residual dilutable volume is approx. 18 gal (69 l).

The residues in the tank should be diluted immediately in a ratio of 1:10 with clean water and then sprayed on the crop just sprayed with increased driving speed. However, it must be noted that the liquid in the spray lines (with unchanged concentration) will be sprayed out first. Therefore there should be an untreated field area available to spray this liquid out.

In addition, the rinsing tank is used to separately rinse pump.

Follow all regulations when disposing of chemical residues.

Using the Drain Valve

The drain valve is operated from the platform just beside the main tank lid.

1. Pull the string to open the drain valve.
2. The valve is spring-loaded, but can be kept open by pulling the string upwards in the V-shaped slit.
3. To release, pull the string downward and the valve will close automatically.

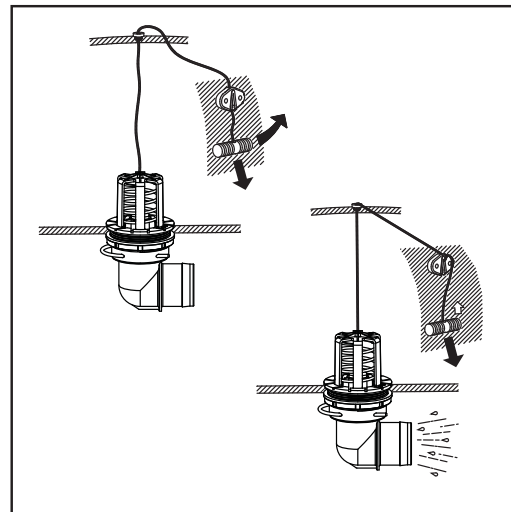

Lubrication

General Info

Always store lubricants clean, dry and cool - preferably at a constant temperature - to avoid contamination from dirt and condensed water. Keep oil filling jugs, hoppers and grease guns clean, and clean the lubricating points thoroughly before lubricating. Avoid skin contact with oil products for longer periods.

Always follow the quality and quantity recommendations. If no quantity is recommended, feed the lubricator until new grease becomes visible.





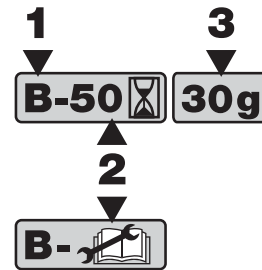

Pictograms in Lubrication & Oiling Plans Designate:

1. Lubricant to be used (see "Recommended lubricants" below).
2. Recommended intervals. Shown in hours or with a symbol for occasional maintenance.
3. Amount to be used. Only shown if an amount is specified.



 **ATTENTION!** If the sprayer has been cleaned with a high pressure washer, lubrication of the entire machine is recommended.

Recommended Lubricants

| What to Lubricate? | Lubricant Type | Factory Use | Suitable Alternatives |
|---|---|--|--|
|  BALL BEARINGS and PUMP | Lithium based grease Consistency NLGI grade 2 Viscosity (@40°C) > 460 cSt | SHELL Gadus S3 V550L 1 HARDI® pump grease cartridge (400g): Item no. 28164600 | MOBIL grease XHP 462 TOTAL Multis Complex SHD 460 |
|  SLIDE BEARINGS | Lithium based grease Consistency NLGI grade 1/2 Viscosity (@40°C) > 200 cSt | MOBIL XHP 222 | SHELL Gadus S3 V220C 2 TOTAL Multis Complex SHD 220 |
|  OIL LUBRICATION POINTS | Engine or transmission oil Viscosity 20W-50 or 80W-90 | OK Tractor UTTO GL 4 80W | SHELL Spirax S4 TXM CASTROL ACT EVO 4T MOBIL Mobilube HD 80W/90 |
|  BOLTS | Anti-corrosive wax | PAVA PV 700 | TECTYL 506 WD |
|  VALVES and SEALS (O-RINGS) | NSF 51, NSF 61 silicone compound | ROCOL SAPPHIRE Aqua-Sil | DOW CORNING MOLYKOTE 111 Compound |
|  HYDROSTATIC FAN TRANSMISSION | Hydraulic oil, type ISO VG 46, ISO 11158 ASTM D6158-05 DIN 51524-3 | OK Hydraulic HVI 46 | SHELL Tellus S2 VX 46 CASTROL HYSPIN AWH-M 46 MOBIL DTE Excel 46 |
|  GEARBOX | Gear oil, type ISO VG 220 Fully synthetic | MOBIL SHC 630 | |
|  HYDRAULICS, HYDRAULIC SUSPENSION | Hydraulic oil type ISO VG 46, ISO 11158 ASTM D6158-05 DIN 51524-3 | OK Hydraulic HVI 46 | SHELL Tellus S2 VX 46 CASTROL HYSPIN AWH-M 46 MOBIL DTE Excel 46 |

6 - Maintenance

Grease Nipple

When lubricating the sprayer, please use a greasing gun which fits the dimensions of the grease nipples.

Nipple head type: DIN 71412

Nipple head size (A): 6.5 mm



ATTENTION! If grease is leaking from the nipple near its threaded part when grease is being applied, tighten the nipple by using a wrench or socket. Replace the nipple if it is damaged or bent out of shape.



ATTENTION! If applying grease into the nipple seems difficult, unscrew the nipple. Check if the nipple is blocked inside, or if the spring-loaded ball is stuck. Clean or repair as needed.



Grease Gun Calibration

Before lubricating the sprayer, you must calibrate your grease gun to ensure that the correct amount of grease is applied to each lubrication point. The correct amount of grease applied will prolong the lifetime of the sprayer.

Calibration Example

1. Insert the correct grease cartridge in your grease gun.
2. Apply grease onto a tissue or a piece of paper. Complete 10 full strokes of the grease gun.
3. Place the paper with grease on a scale (A).
4. If your grease pile weighs e. g. 10 grams (0.4 oz.), then 1 stroke equals 1 gram (0.04 oz.) of grease.

When calibrated, you can count how many strokes to complete when lubricating the different grease points on the sprayer according to the specifications.

Alternative Method

1. Count the strokes, until you have 10 grams (0.4 oz) of grease piled up on the scale (A).
2. Now you can figure out how many strokes to use for applying a certain amount of grease to a lubrication point.

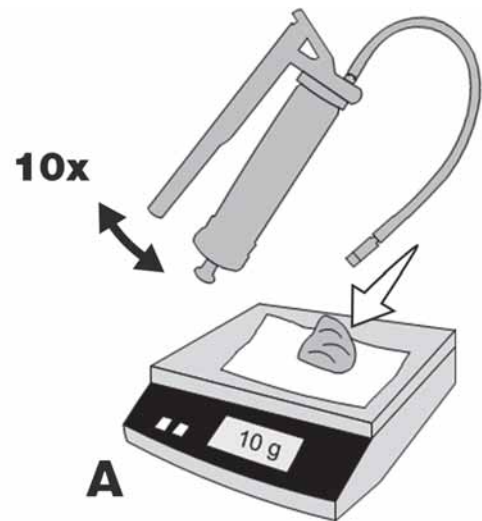

Lubrication and Oiling Plan (Boom Width: 80' - 100')

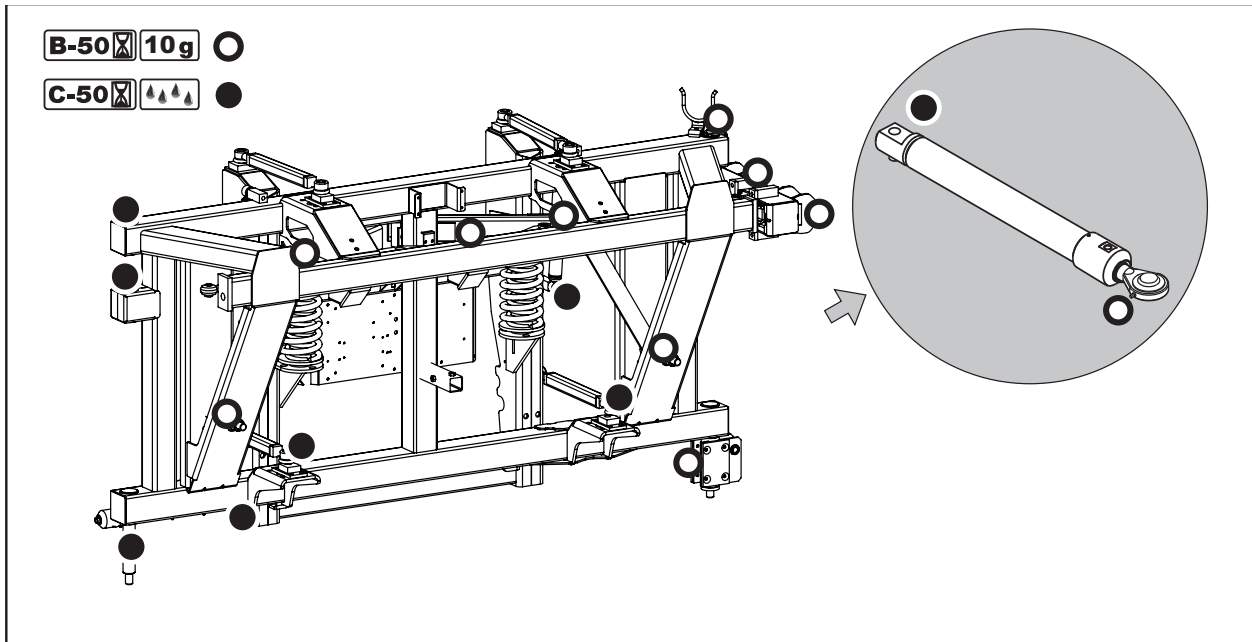
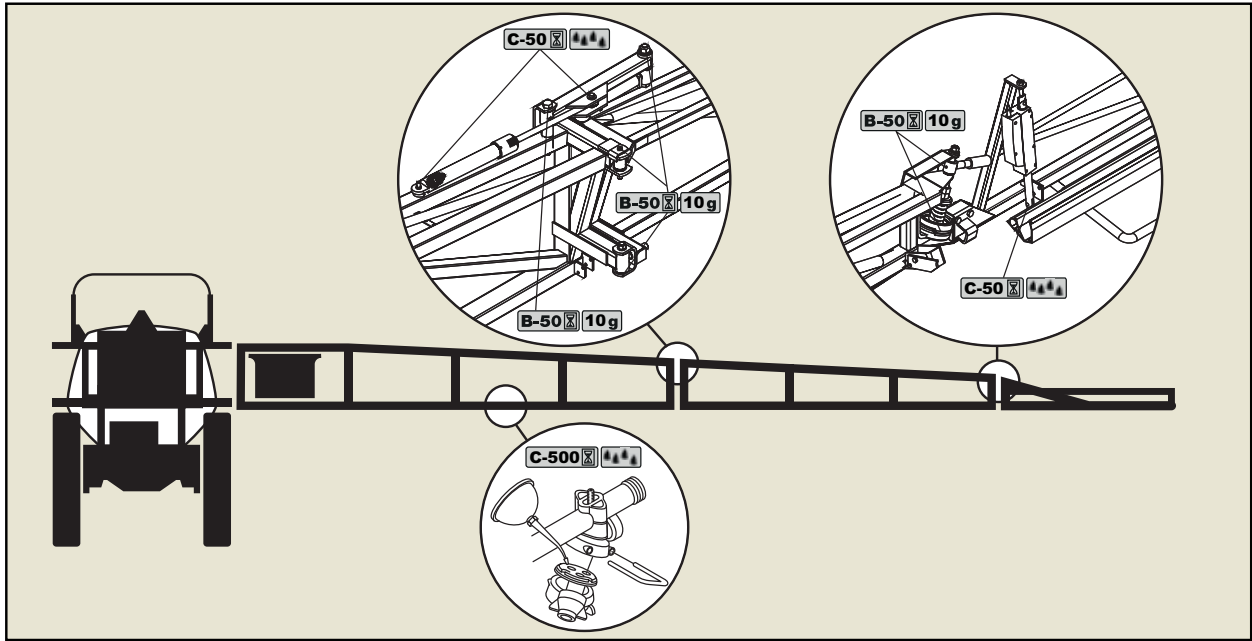

6 - Maintenance

Lubrication and Oiling Plan (Boom Width: 120')

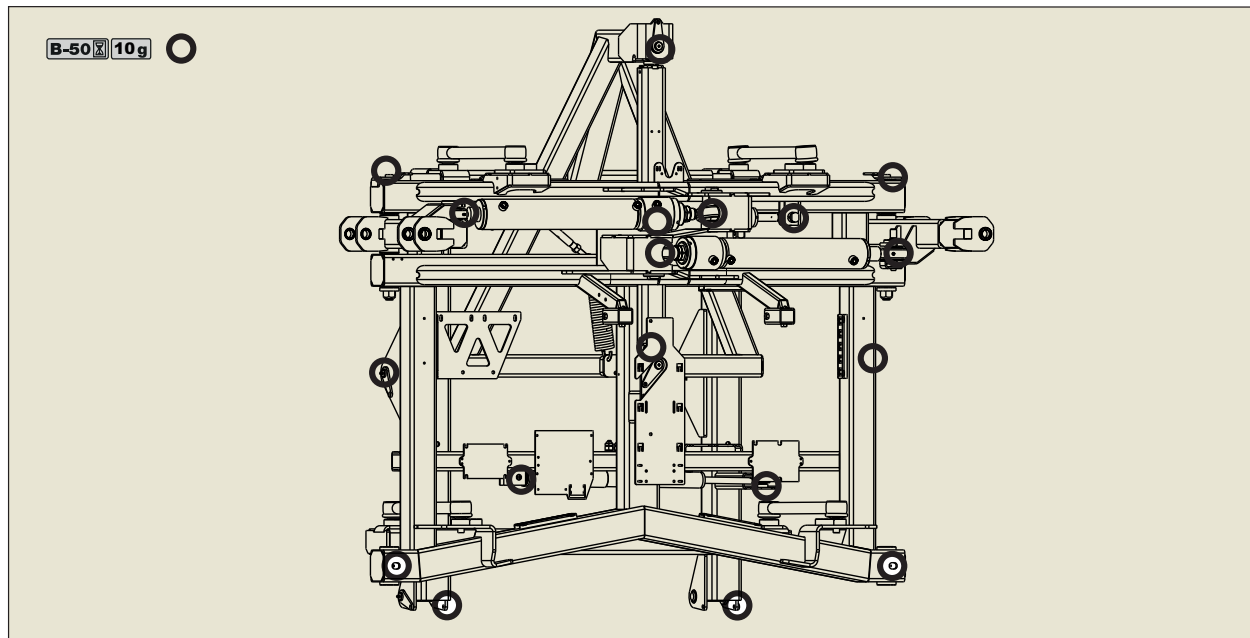
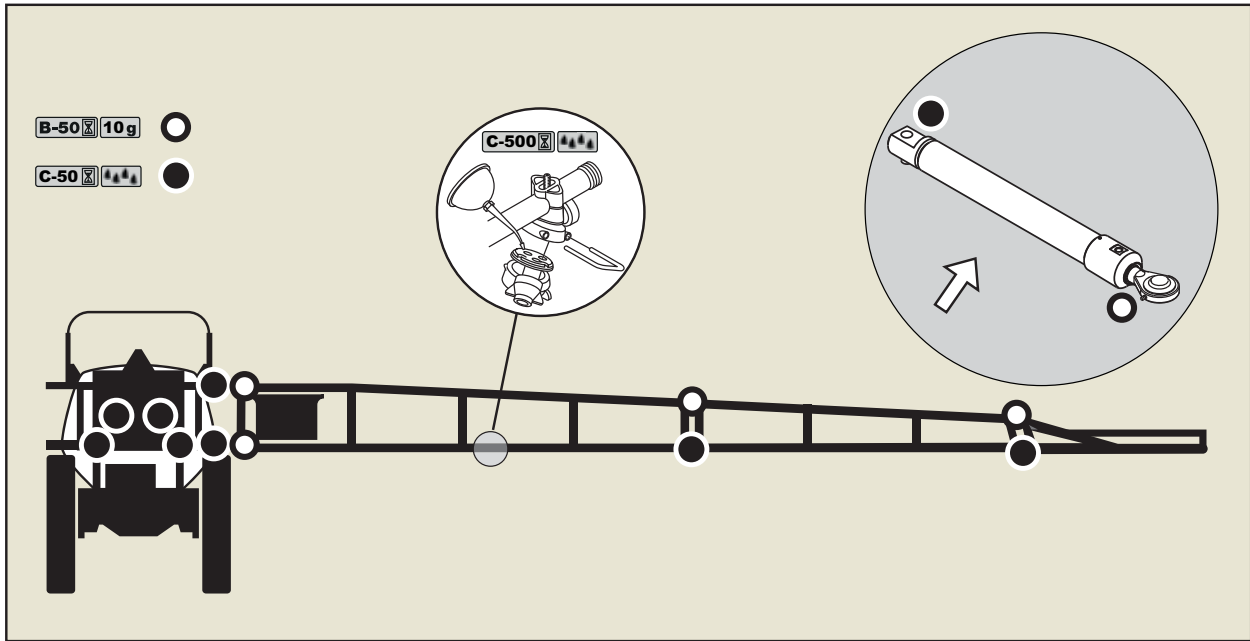

Lubrication Plan - Trailer / Paralift

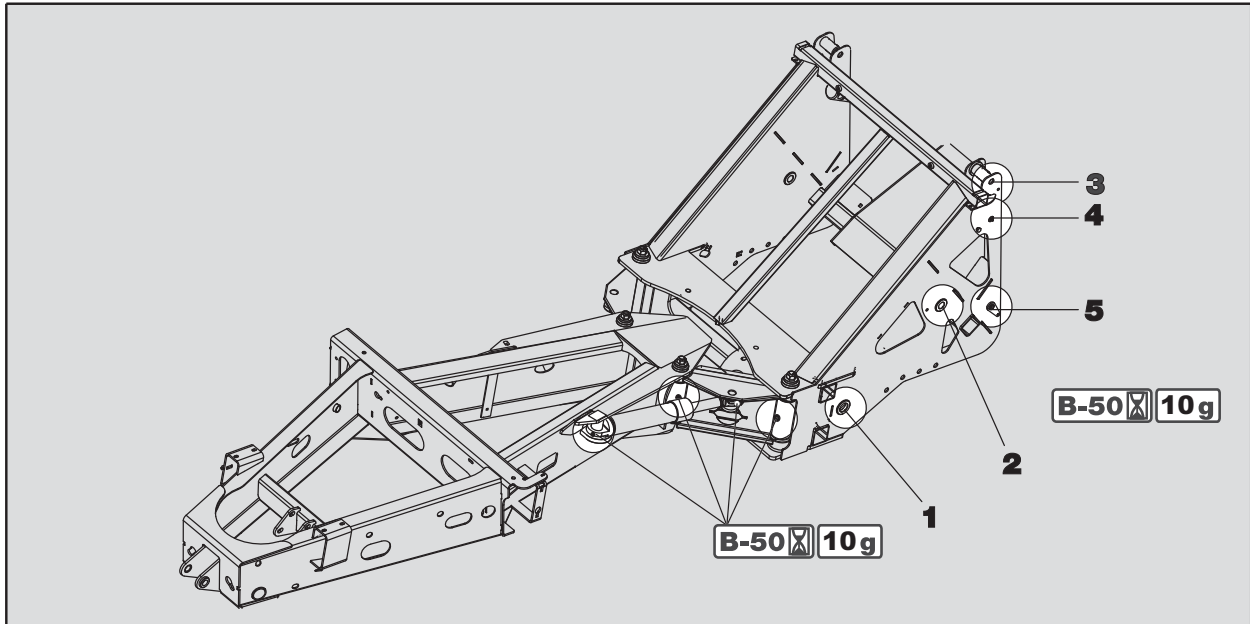

i NOTE! Positions 1 and 2 are for suspended sprayers only.

Paralift

There are 3 grease points on each side.

Central Lubrication

The grease nipples are located at the rear of the chassis in both sides.

Depending on the sprayer setup, there can be 0, 3 or 5 grease nipples to be lubricated on each side.

Replace the dust caps after lubrication.



6 - Maintenance

Lubrication and Oiling Plan - PTO

The amount of grease to be applied is mentioned in grams (g). Test your grease gun to see how many grams it supplies, for example after 5 strokes.

 **ATTENTION!** The correct amount of grease applied at the intervals is important. Too little or too much grease will shorten the lifetime of the PTO.

The grease points and amount of grease to be applied are shown in the pictures below together with the intervals.

Standard PTO for Tractor and Sprayer

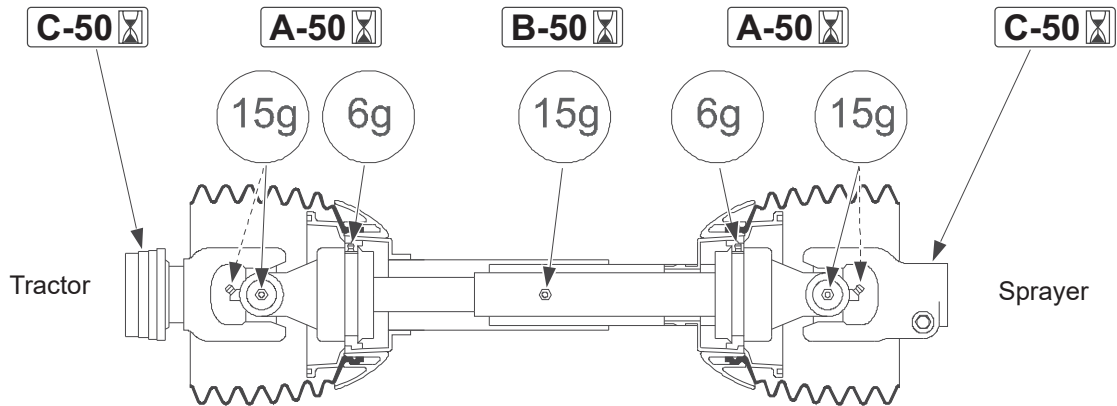

Wide Angle PTO for Tractor, Standard PTO for Sprayer

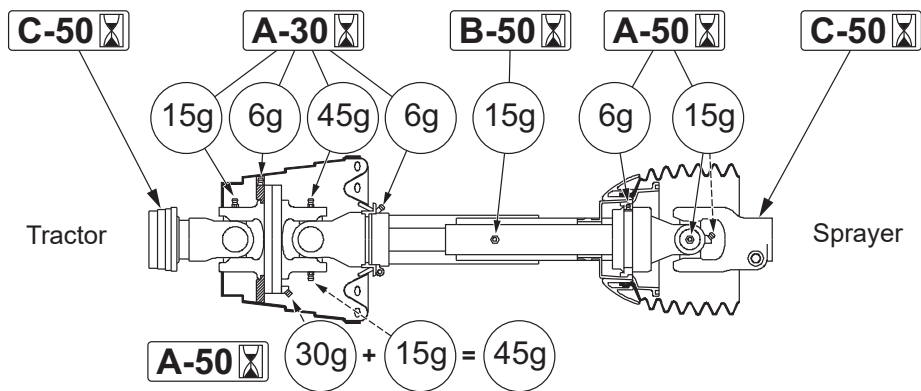

Wide Angle PTO for Both Tractor and Sprayer

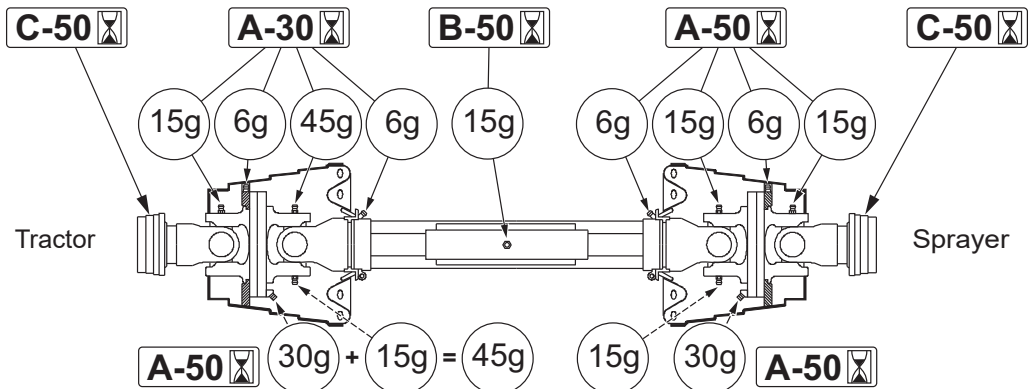

Greasing the Pump

The pump is greased as follows:

- Factory greased:
300 g grease into each lubrication point (A).
- Normal operation:
Greasing every 50 hours with 30 grams of grease into each lubrication point (A). See also "50 Hours Service - Greasing the Pump" on page 106.
- After disassembling the pump (diaphragm replacement, etc.):
Greasing with 200 grams of grease into each lubrication point (A).



ATTENTION! In order to prevent excessive wear, it is important to use a recommended lubricant (i.e. HARDI® part no. 28164600). See "Recommended Lubricants" on page 95.



ATTENTION! The pump MUST be stopped during greasing!

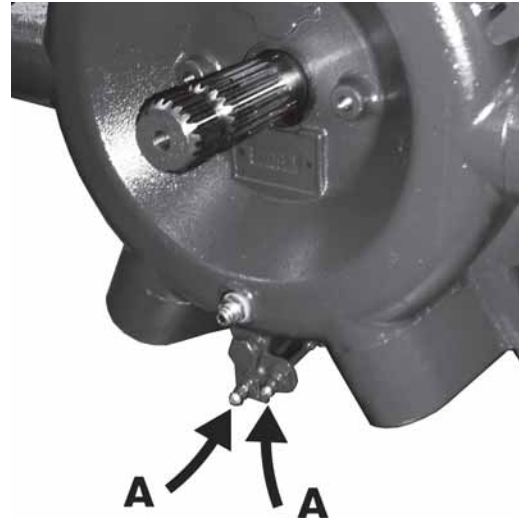

6 - Maintenance

Service and Maintenance Intervals

Tightening Bolts and Nuts

When tightening bolts and nuts as a part of periodic service or due to replacement of spare parts, it is important to apply the correct torque. This will prevent accidents and prolong the lifetime of the parts included in the bolted joints.

If not otherwise stated in this book, please tighten bolts and nuts using the following torques.

| Material: Surface treated steel | | | Material: Stainless steel | | |
|---------------------------------|---------------------|----------------------|---------------------------|--------------------|---------------------|
| Bolt size (metric) | Recommended torque | Maximum torque* | Bolt size (metric) | Recommended torque | Maximum torque* |
| M4 | 21 In/lb (2.4 Nm) | 27 In/lb (3 Nm) | M4 | 15 In/lb (1.7 Nm) | 19 In/lb (2.1 Nm) |
| M5 | 44 In/lb (5 Nm) | 53 In/lb (6 Nm) | M5 | 31 In/lb (3.5 Nm) | 37 In/lb (4.2 Nm) |
| M6 | 71 In/lb (8 Nm) | 89 In/lb (10 Nm) | M6 | 50 In/lb (5.6 Nm) | 62 In/lb (7.0 Nm) |
| M8 | 15 Ft/lb (20 Nm) | 18 Ft/lb (25 Nm) | M8 | 124 In/lb (14 Nm) | 155 In/lb (17.5 Nm) |
| M10 | 29 Ft/lb (39 Nm) | 37 Ft/lb (50 Nm) | M10 | 20 Ft/lb (27 Nm) | 26 Ft/lb (35 Nm) |
| M12 | 52 Ft/lb (70 Nm) | 63 Ft/lb (85 Nm) | M12 | 36 Ft/lb (49 Nm) | 44 Ft/lb (60 Nm) |
| M14 | 83 Ft/lb (112 Nm) | 103 Ft/lb (140 Nm) | M14 | 58 Ft/lb (78 Nm) | 72 Ft/lb (98 Nm) |
| M16 | 133 Ft/lb (180 Nm) | 159 Ft/lb (215 Nm) | M16 | 93 Ft/lb (126 Nm) | 111 Ft/lb (151 Nm) |
| M18 | 177 Ft/lb (240 Nm) | 225 Ft/lb (305 Nm) | M18 | 124 Ft/lb (168 Nm) | 158 Ft/lb (214 Nm) |
| M20 | 258 Ft/lb (350 Nm) | 321 Ft/lb (435 Nm) | M20 | 181 Ft/lb (245 Nm) | 225 Ft/lb (305 Nm) |
| M22 | 361 Ft/lb (490 Nm) | 435 Ft/lb (590 Nm) | M22 | 253 Ft/lb (343 Nm) | 305 Ft/lb (413 Nm) |
| M24 | 443 Ft/lb (600 Nm) | 553 Ft/lb (750 Nm) | M24 | 310 Ft/lb (420 Nm) | 387 Ft/lb (525 Nm) |
| M27 | 720 Ft/lb (976 Nm) | 811 Ft/lb (1100 Nm) | M27 | 504 Ft/lb (683 Nm) | 568 Ft/lb (770 Nm) |
| M30 | 959 Ft/lb (1300 Nm) | 1103 Ft/lb (1495 Nm) | M30 | 671 Ft/lb (910 Nm) | 772 Ft/lb (1047 Nm) |

*Exceeding this value results in a great risk of deforming the bolt.



WARNING! Applying too little torque will result in these risks:

- bolted joints will rattle and thus fail under fatigue
- bolts are being worn quickly and thus will not fulfill their design purpose
- bolted joints will come loose
- accidents caused by assembled parts coming apart due to bolts or nuts failing or falling off.



WARNING! Exceeding the maximum torque will result in these risks:

- damaging or stripping the threads and deforming the bolt
- bolt heads will be broken
- bolted joints will come loose
- accidents caused by assembled parts coming apart due to bolts breaking at a later time.

Tightening Hydraulic Hoses

When tightening hydraulic hoses as a part of periodic service or due to replacement of spare parts, it is important to apply the correct torque. This will prevent accidents and prolong the lifetime of the parts connected with the hoses.

If not otherwise stated in this book, please tighten hydraulic hoses using the following torques:

| Hose size | Thread size | Wrench size | Recommended torque |
|-----------|-------------|-----------------|--------------------|
| 1/4" | 9/16" | 3/4" (19 mm) | 21 Ft/lb (28 Nm) |
| 3/8" | 11/16" | 7/8" (22 mm) | 32 Ft/lb (44 Nm) |
| 1/2" | 13/16" | 15/16" (24 mm) | 46 Ft/lb (62 Nm) |
| 3/4" | 13/16" | 1-7/16" (36 mm) | 96 Ft/lb (130 Nm) |



DANGER! A hydraulic hose or joint leaking or coming apart with the oil under pressure can cause severe injuries to persons standing nearby! The oil can be very hot, around 176° F (80 °C), and the oil streaming out can penetrate human skin. Risk of burns on the skin, internal injuries and facial injuries.



WARNING! Applying too little torque will result in these risks:

- hydraulic joints will leak due to the high oil pressure.
- hydraulic joints will rattle and thus fail under fatigue.
- hydraulic joints are being worn quickly and thus will not fulfill their design purpose.
- accidents caused by sudden loss of oil pressure due to hydraulic parts coming apart.



WARNING! Applying too much torque will result in these risks:

- damaging or stripping the threads and deforming the hydraulic joints.
- fittings will be broken.
- hydraulic joints will leak.
- accidents caused by assembled parts coming apart due to bolts breaking at a later time.



WARNING! When assembling a hydraulic joint, this is often being twisted around in different directions to make it fit between other components on the sprayer. Remember to finish off by applying the correct torque.



NOTE! The sealing system for hoses and fittings is ORFS type (O-Ring Face Seal). This ensures a high level of sealing and good vibration resistance. The fittings use the O-ring compression mechanism to seal.

10 Hours Service - Spraying Circuit

Fill with clean water and operate all functions.

Check for leaks using a higher spray pressure than normal.

Check nozzle spray patterns visually using clean water.

6 - Maintenance

10 Hours Service - EasyClean Filter

This filter has a clogging indicator, but even if this indicator does not show clogging, it should be cleaned every 10 hours.

Servicing the Filter

1. Turn the filter lid counter-clockwise to open it.
2. Remove lid and filter from the filter housing.

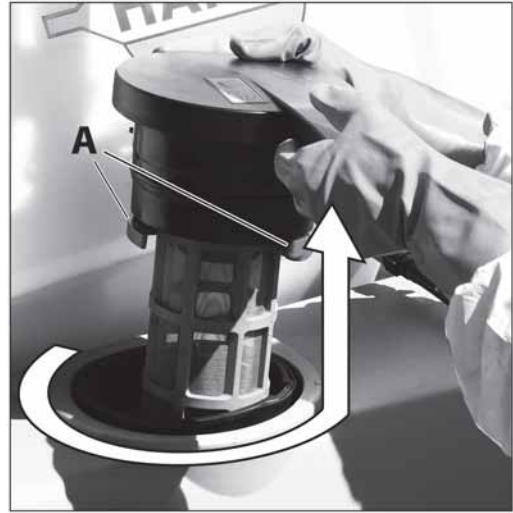

3. Separate filter element from lid/filter guide by turning locks (A) outwards.
4. Clean filter and, if necessary, clean the housing for larger impurities.

To Reassemble

1. Grease the O-ring on the filter lid.
2. Press the filter onto the filter guide/lid. Make sure that it has caught the guide. Locks (A) are turned inwards.
3. Reassemble filter/filter lid into the housing. Make sure that it has caught the guide in the bottom of the housing.
4. Turn the filter lid clockwise to close it.

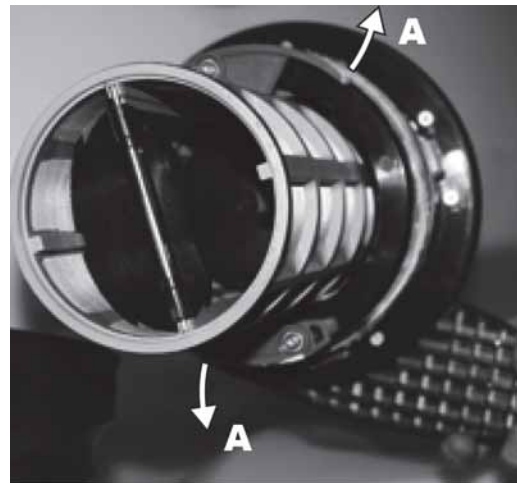

WARNING! Always wear protective clothing and gloves before servicing the filter!



ATTENTION! If you have difficulties opening the filter, see "Emergency Operation - EasyClean Filter" on page 148.

10 Hours Service - In-Line Filter

If the boom is equipped with In-Line filters, unscrew the filter bowl to inspect and clean the filter. When reassembling, the O-ring should be greased.

Alternative filter meshes are available. See "Filters" on page 152.



WARNING! Be careful not to splash out liquid when unscrewing the filter bowl.



WARNING! Always wear protective clothing and gloves before servicing the filter!

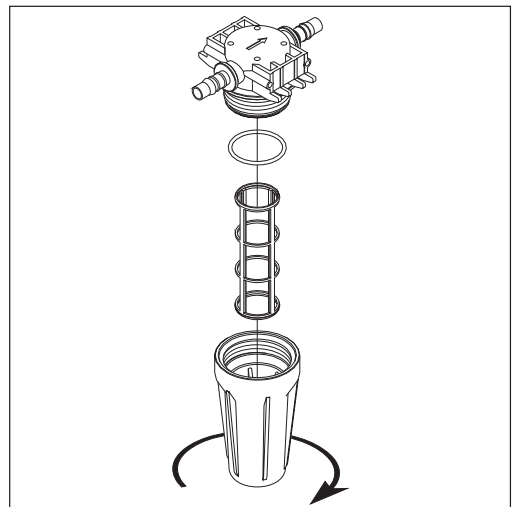

10 Hours Service - CycloneFilter

Servicing the Filter

1. Turn the pressure SmartValve to a function other than "Spraying".
2. Unscrew the filter lid (A).
3. Lift lid and filter (B) away from the housing.
4. Turn the two locks (C) outwards to unlock the filter from the lid.
5. Separate filter from the integrated filter guide in the lid. Clean the filter.

To Reassemble

1. Grease the two O-rings on the lid/filter guide. Due to small space at the lid, use brush or similar item to apply the grease.
2. Mount the filter onto the recess (do not grease) in the lid/filter guide.
3. Turn the two locks (C) inwards to lock the filter into position.
4. Place the filter/filter lid into the housing and screw the lid until it hits the stop.

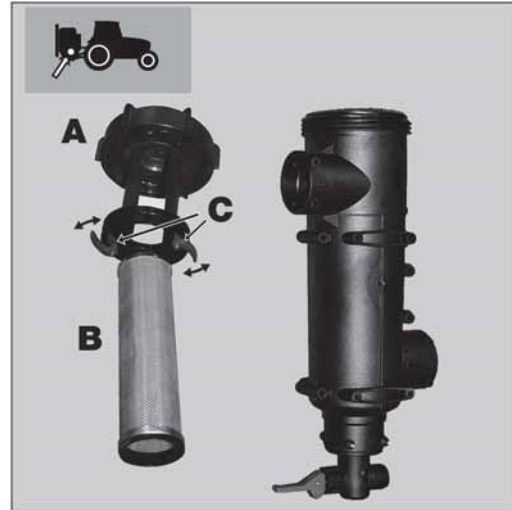

WARNING! Always wear protective clothing and gloves, before servicing the filter!



DANGER! Never open the CycloneFilter unless the pressure SmartValve is closed (turned to unused position). Otherwise, contaminated spray liquid can escape when opening the filter, and drain the main tank contents

10 Hours Service - Nozzle Filters

The filters are located in the nozzle holder.

Check the filter condition and clean the filter.



10 Hours Service - Hydraulic Oil Level

Check the oil level in the tank. The oil level must cover the sight glass. The minimum oil level is indicated by the red line.

If the oil level is too low, clean the area around the filling cap carefully and fill fresh, clean oil.

For details on oil type, see "Recommended Lubricants" on page 95.



6 - Maintenance

50 Hours Service - Greasing the Pump

When operating the pump, it must be greased every 50 hours with 30 grams of grease into each lubrication point.



ATTENTION! In order to avoid excessive wear, it is important to use a recommended lubricant (i.e. HARDI® part no. 28164600). See "Recommended Lubricants" on page 95 for more information.



ATTENTION! The pump MUST be stopped during greasing!

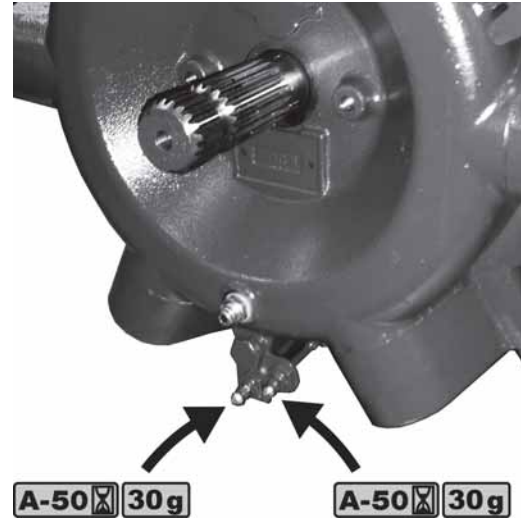

50 Hours Service - Wheel Nuts

Tighten wheel nuts as follows:

Mounting wheel hub to rim plate: Torque 360 Ft/lb (490 Nm).

Tightening sequence: See illustration and tighten in the order of numbering.



50 Hours Service - Tire Pressure

Check the tire pressure according to the table in "Tire Pressure" on page 149.



DANGER! Never inflate tires more than to the pressure specified in the table. Over-inflated tires can explode and cause severe injuries! See the section "Occasional Maintenance - Change of Tires".



WARNING! If renewing tires, always use tires with minimum load index as specified.



50 Hours Service - Gearbox for TWIN System, Bolts

Check that the two mounting bolts on the gearbox are not loose.
Tighten the bolts if needed. Torque: 74 Ft/lb (100 Nm).

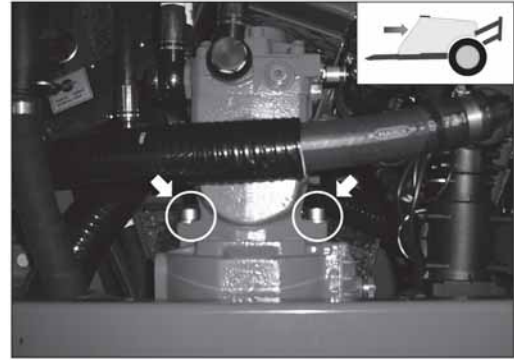

50 Hours Service - Transmission Shaft (PTO)

1. Check function and condition of the transmission shaft protection guard. Replace any damaged parts.
2. Lubrication. See "Lubrication and Oiling Plan - PTO" on page 100.



50 Hours Service - Hydraulic Oil for TWIN System, Filter Change

Next filter change is after 500 hours or once a year, whichever comes first.

Always change the oil filter if the pressure gauge indicates a red area, meaning that the filter is clogged. Only the green area is suitable for operation of the TWIN air system.

Check the filter for clogging once every 10 working hours when the oil has reached working temperature.

How to Change the Filter

1. Place a collection tray or a cloth under the filter (A) to collect waste oil. Unscrew the filter cartridge.
2. The new filter cartridge is filled with fresh hydraulic oil. Apply a thin oil film to the cartridge seal.

For details on oil type, see "Recommended Lubricants" on page 95.

3. Screw on the new filter cartridge until the seal is lying against the flange.
4. Tighten the filter cartridge another 1/2 to 3/4 turn.
5. Check the oil level - fill oil if needed. When the oil level covers the sight glass (B), the filling is completed. The minimum oil level is indicated by the red line in the sight glass.



ATTENTION! Dispose of used hydraulic filter cartridges and waste oil in accordance with local legislation.

6 - Maintenance

50 Hours Service - Gearbox for TWIN System, Oil Change

Next oil change is after 500 hours or once a year, whichever comes first.

The oil change should be carried out when the machine has been running for at least one hour so that the oil is at working temperature.

The gearbox is installed just behind the main pump.

1. Lift up the rear part of the platform and remove it temporarily
The red gearbox is found below the remaining part of the platform.



2. Remove the drain plug from the gearbox (B) to drain away the oil.
The drain plug is similar to this plug (C).
Collect the waste oil and dispose of it according to local legislation.
3. Once the oil is drained completely, replace the drain plug.
4. Remove the filling plug (D).
Fill new oil into the gearbox, approx. (37 oz.) (1.1 liters).
For details on oil type, see "Recommended Lubricants" on page 95.
Replace the filling plug.

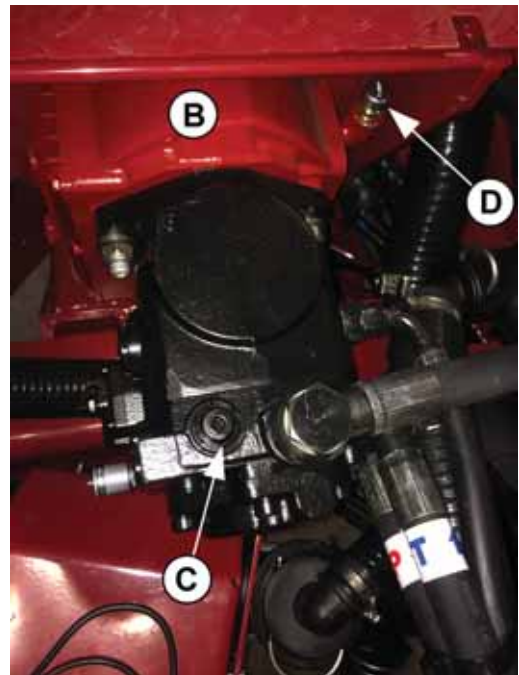

100 Hours Service - Check / Tighten Steering

If too much play is found in the steering section, it must be re-tightened. This applies to both steering and non-steering versions. Re-tighten the nuts on both sides to the specified torque.



ATTENTION! Specified torque is 185 Ft/lb (250 Nm).

Be sure that the split pin is fitted (or refitted if dismantled) at the end of the big bolts.

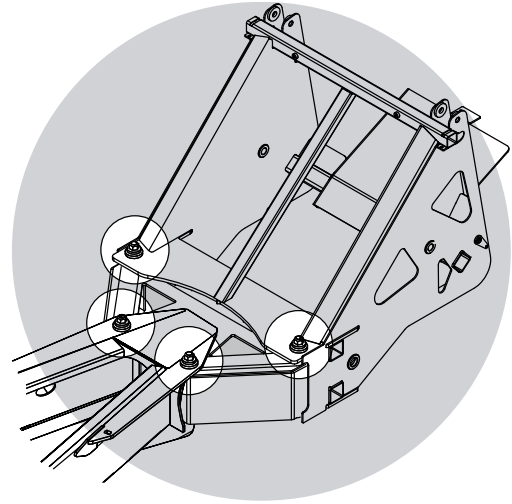

100 Hours Service - Re-tightening the Spray Boom

Due to several movements of the spray boom from driving in the field with an unfolded boom, you must re-tighten all bolted connections on the boom center and boom wings.

Where you find bolts with Nord-Lock washers, please tighten with the following torques.

| Bolt size | Torque |
|-----------|--------------------|
| M10 | 37 Ft/lb (50 Nm) |
| M12 | 63 Ft/lb (85 Nm) |
| M14 | 100 Ft/lb (136 Nm) |
| M16 | 153 Ft/lb (208 Nm) |
| M18 | 215 Ft/lb (291 Nm) |
| M20 | 301 Ft/lb (408 Nm) |
| M22 | 411 Ft/lb (557 Nm) |
| M24 | 519 Ft/lb (703 Nm) |
| M27 | 519 Ft/lb (703 Nm) |
| M30 | 519 Ft/lb (703 Nm) |

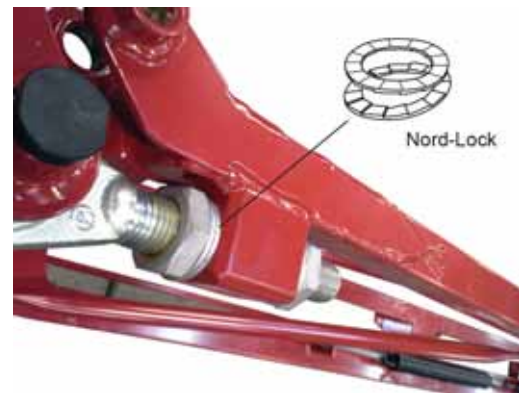

6 - Maintenance

250 Hours Service - Hydraulic Circuit

Check the hydraulic circuit for leaks. Repair if needed.

Refill nitrogen accumulators for:

- ParaLift suspension
- Wheel axle suspension (if fitted)
- Yaw suspension (if fitted)



WARNING! Nitrogen accumulators may contain oil under pressure.

250 Hours Service - Hoses and Tubes

Check all hoses and tubes for possible damage and proper attachment. Replace damaged hoses or tubes.

In general, a hose or tube should always be replaced, if:

- it is leaking
 - reinforcement material inside the hose is visible due to cracks in the outer layers.
-

250 Hours Service - Wheel Bearings

Check for play in the wheel bearings:

1. Place stop wedges in front of and behind LH wheel and jack up RH wheel.
2. Rock the RH wheel to discover possible play in the bearings.
3. If any play, support the wheel axle to prevent the trailer from falling down from the jack.
4. Remove hub cap (A) and cotter pin (B). Turn the wheel and tighten the castle nut (C), until a slight resistance is felt in the wheel rotation.
5. Loosen the castle nut until the first notch - horizontal or vertical - is aligned with the cotter pin hole in the shaft.
6. Fit a new cotter pin and bend it to keep it in place.
7. Fill the hub cap with fresh grease and re-attach it onto the hub.
8. Repeat the procedure for the left wheel.

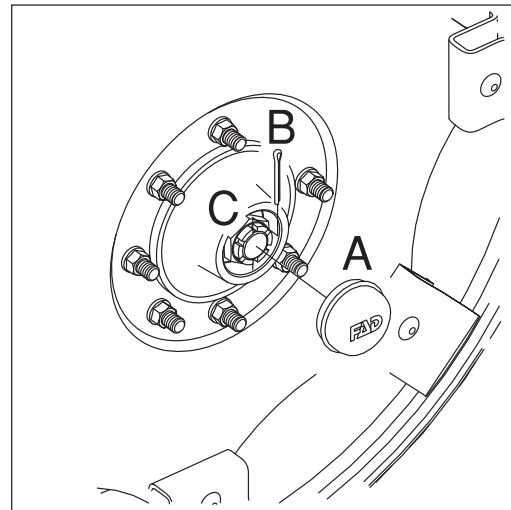

NOTE! Some hub caps are attached with screws. Make sure the seal is intact or replace if worn!

500 Hours Service - Hydraulic Oil for TWIN System, Filter Change

See "50 Hours Service - Hydraulic Oil for TWIN System, Filter Change" on page 107.

500 Hours Service - Gearbox for TWIN System, Oil Change

See "50 Hours Service - Gearbox for TWIN System, Oil Change" on page 108.

1000 Hours Service - Hydraulic Oil for TWIN system, Oil Change

Next oil change is after 1000 hours or once a year, whichever comes first.

The oil change should be carried out when the machine has been running for at least one hour so that the oil is at working temperature.

The oil tank (A) is installed near the platform.

How To Find The Filling Point

1. Stand on the platform.
2. Pull the plastic hose (B) out of the clamps and place it on the platform.
3. Unscrew the thumb screws (C).
4. Lift away the vertical plate (D) and place it temporarily up against the handrail to the right.

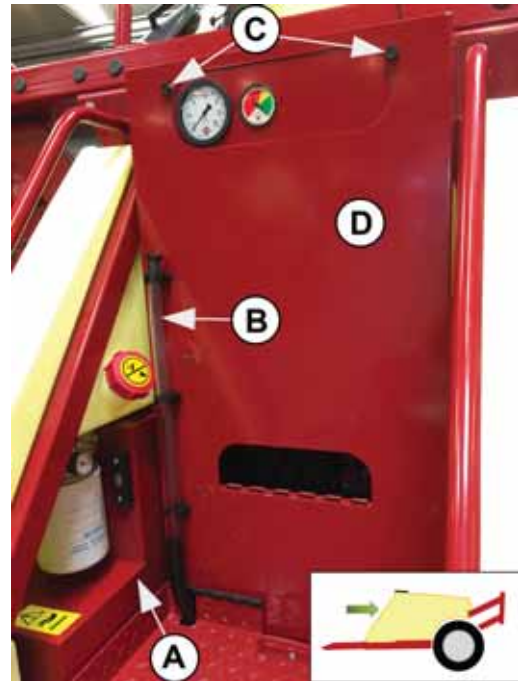

Filler neck and filling cap (E) for the oil tank is placed next to the clean water tank.

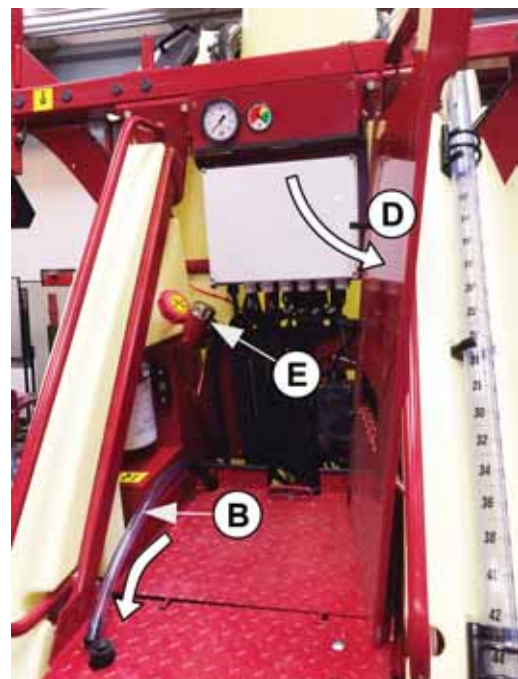

6 - Maintenance

How To Change The Oil

The drain valve for the tank is found behind the CycloneFilter.

Lift away the gray side cover on the right side of the sprayer to access the drain valve (G).

5. Unscrew the drain cap (F).
Connect a hose to the drain valve (G), size 1/2".
Lead this hose to a container for collecting the waste oil and dispose of it according to local legislation.
Now open the valve to drain the tank.
6. Once the oil is drained completely, close the valve and replace the drain cap.
- Check the condition of the drain seal. Replace if needed.
7. Unscrew the filling cap (E).
Fill new oil into the tank, approx. 58 quarts (55 liters).
For details on oil type, see "Recommended Lubricants" on page 95.
8. When the oil level covers the sight glass (H), the filling is completed. The minimum oil level is indicated by the red line in the sight glass.
Replace the filling cap and wipe off any spilled oil.



1000 hours service - Wheel bearings

Check the condition of the bearings in the following way:

1. Place stop wedges in front of and behind LH wheel and jack up RH wheel.
2. Support the trailer with axle stands.
3. Remove the wheel.
4. Unscrew the 4 bolts and remove the hub cap (A), cotter pin (B) and castle nut (C).
5. Pull off the wheel hub assembly (D). Use a wheel puller if necessary.
6. Remove roller bearings (E), clean all parts in degreasing detergent and dry them. Inspect bearings (E) and replace if necessary.
7. Pack bearings (E) with fresh wheel bearing grease and re-install using a new seal (F).
8. Turn the wheel and tighten the castle nut (C) until a slight resistance in the wheel rotation is felt.
9. Loosen the castle nut until the first notch (horizontal or vertical) is aligned with the cotter pin hole on the shaft.
10. Fit a new cotter pin and bend it.
11. Fill the hub cap with fresh grease and re-attach it onto the hub.
12. Repeat the procedure on the LH wheel.

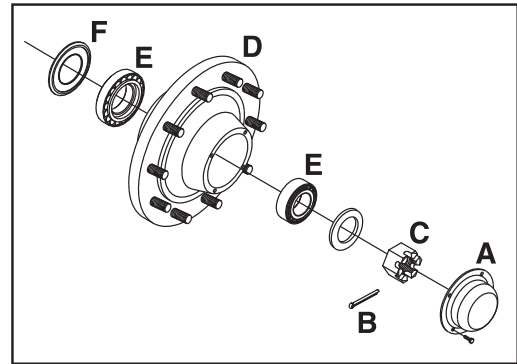

ATTENTION! The spindle has two holes available for the cotter pin. Use the one first aligned with the notch when loosening the castellated nut.



WARNING! If you do not feel totally confident changing wheel bearings, contact your HARDI® dealers workshop.

6 - Maintenance

Occasional Maintenance

General Info

The maintenance and service intervals for the following components will depend very much on the conditions under which the sprayer is operated, and therefore it is almost impossible to specify the intervals beforehand.

The operator must select appropriate intervals for the occasional maintenance.

If in doubt, contact your local HARDI® dealer.

Lifting and Removing the Pump

When lifting and removing the pump, use a shackle fitted to the built-in lifting eye located between the heads (A).



WARNING! To prevent damages in case of a free-falling pump, use lifting gear and a steel shackle with at least 4 tons max. tensile strength.



NOTE! Pump weight is approximately 165 lb (75 kg).



Pump Valves and Diaphragms Replacement

Diaphragm pump overhaul kit (valves, seals, diaphragms etc.) can be ordered. Detect the pump model - kit can be ordered using correct HARDI® part No.:

Model 464: part No. 75586000

1. Lift off the plastic covers (C) with your hands (A) by pulling with the finger tips while pushing with the thumbs in the center, as shown in (B).



Valves

2. Loosen the 4 head bolts (1).
3. Remove the head (2).
4. Change the valves (3) - note their orientation so that they are replaced correctly!

 **ATTENTION!** It is recommended to use new gaskets (4) when changing or checking valves.

Diaphragms

5. Loosen the diaphragm bolt (5).
6. Remove the diaphragm washer (6).
7. The diaphragm (7) may then be changed.
8. Check that the drain hole (8) at the bottom of the pump is not blocked.
9. Apply a small amount of pump grease on the underside of the diaphragms (between diaphragm and connecting rod washer).
10. Reassemble the pump with the following torque setting:
 - Diaphragm head bolts (1): 67 Ft/lb (90 Nm)
 - Diaphragm bolt (5): 67 Ft/lb (90 Nm)
11. Replace the plastic covers (C).

 **NOTE!** The diaphragm bolt on 1000 rpm. pumps must be secured with a locking compound such as Loctite® 262 (HARDI® Part No.: 28045503).

 **ATTENTION!** Before tightening the 4 bolts for the head (2), the diaphragm must be positioned between the center and top to ensure correct sealing between the diaphragm pump housing and diaphragm cover. Turn the crank shaft if necessary.

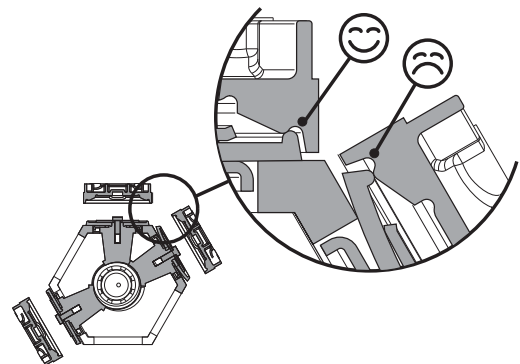
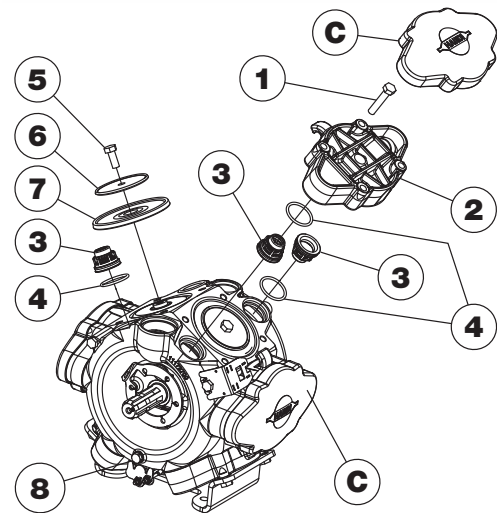

6 - Maintenance

Lubrication After Assembly

After disassembling the pump (diaphragm replacement, etc.), the pump MUST be lubricated with 7 oz. (200 g) grease into each lubrication point.



ATTENTION! In order to avoid excessive wear, it is important to use a recommended lubricant (i.e. Hardi® part no. 28164600). See "Recommended Lubricants" on page 95.

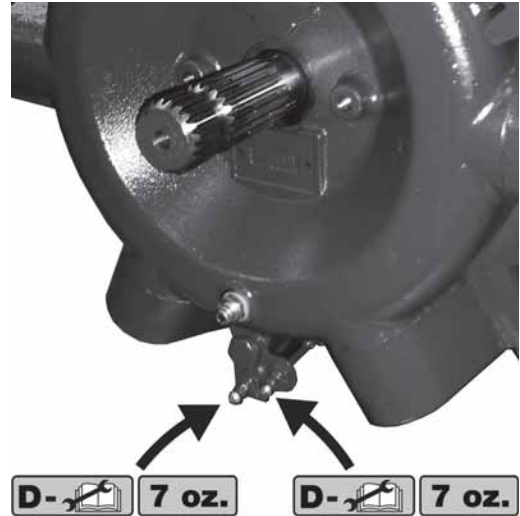

Speed Transducer for Pump

The speed transducer, measuring revolutions per minute (rpm), is located at the inner side of the PTO shield. This sensor is an inductive type, which requires metallic protrusions to pass by it to trigger a signal. If the sensor is replaced, it must be installed accurately to function.

Adjustment

1. Adjust the air gap (A) between sensor tip and pump part by turning the nuts on the support bracket for the sensor.

The air gap (A) must be set to 1 mm (+0.3/-0.0 mm).

Use a feeler gauge or similar tool to verify.

2. Verify transducer function on the controller:
 - HC 6500 / ISOBUS VT:
 - Monitor the menu [4.5.4.9.6 PTO pump frequency].



Level Indicator Adjustment

The level indicator reading should be checked regularly. When the tank is empty, the float should lie on the stop pin (D) of the rod, and the O-ring on the indicator should be positioned at the top position line (A).



ATTENTION! The wire guide wheels should be directed so they follow the direction of the wire.

If any deviation is found, do the following:

1. Pull out the plug (B).
2. Loosen screws (C).
3. Adjust the length of the wire, until it reads correctly.
4. Push the plug (B) back into place.



NOTE! To obtain the best accuracy, the adjustment shall be done with the sprayer attached to the tractor normally used.

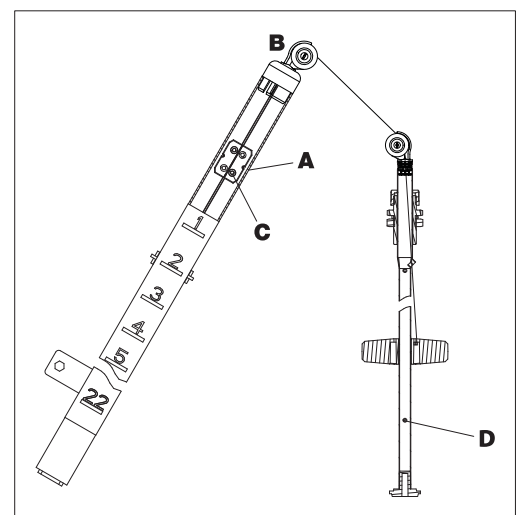

Level Indicator Wire Replacement

If the wire on the level indicator has to be changed, the float guide pole is removed.

1. Remove the tank drain valve (see the next paragraph "Drain Valve Seal Replacement") and loosen the fitting holding the pole in position.
2. Pull the pole down through the drain valve hole until it is free in the top of the tank.
3. The pole can now be taken out of the tank through the filling hole.



DANGER! Do not enter the inside of the tank - the parts can be changed from the outside of the tank!

Drain Valve Seal Replacement

If the main tank drain valve leaks, the seal and seat can be changed in the following way.



DANGER! Do not enter the inside of the tank - the parts can be changed from the outside of the tank!



WARNING! Use eye / face protection mask, when dismantling the tank drain valve!

1. Make sure that the tank is empty and clean.
2. The valve must be closed and the string must be loose.
3. Pull out the clip (A) and pull down the connecting piece (B). The entire valve assembly can now be pulled out.
4. Check cord and valve flap assembly (C) for wear, replace seal (D) and reassemble.
5. Reassemble the valve using a new valve seat (E). Lubricate O-rings (F) before assembly.
6. Fit clip (A) again.

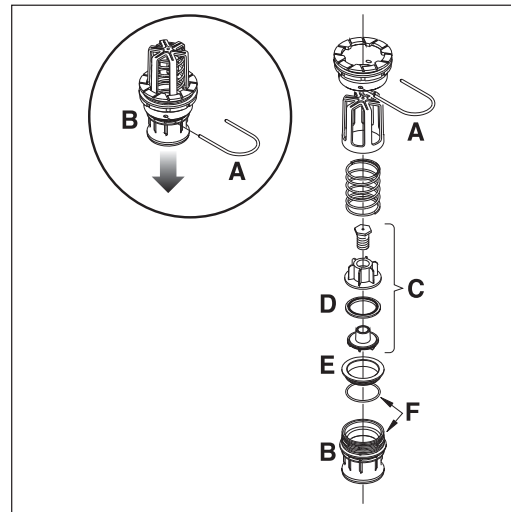

ATTENTION! Check the valve function using clean water, before filling chemicals into the tank.

6 - Maintenance

Feed Pipe Clamp Assembly

A feed pipe can be removed from the pipe clamps the following way:

1. Use a flat bladed screwdriver to pry the cover off the first corner (A).
2. Hold the clamp top with your hand and pry off the opposite corner (B) with the screwdriver.
3. Pry off the other side of the pipe clamp with the screwdriver.
4. Take out the feed pipe.

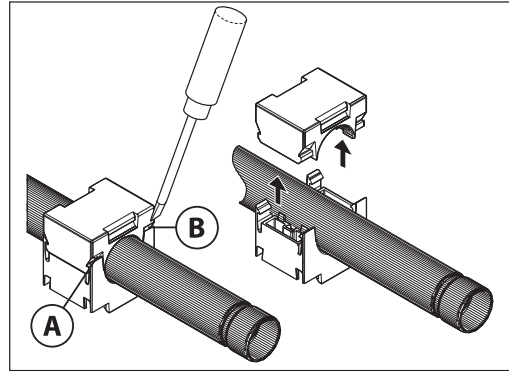

Feed Pipe Snap-Lock Assembly

Disassembly

1. Unscrew the union nut (A) completely.
2. Pull the feed piping and hose barb apart.
3. Take out the O-ring (B).
4. Inspect and oil O-ring (B). Change the O-ring (B) if worn, before reassembly.

Reassembly

1. Check that the barbed lock ring (C) is fitted to the feed pipe with barb pointing away from pipe opening.
2. Fit the oiled O-ring (B) onto the feed pipe next to the lock ring (C).
3. Push the feed pipe and hose barb together.
4. Screw the union nut (A) on the hose barb and tighten union nut (A) by hand.

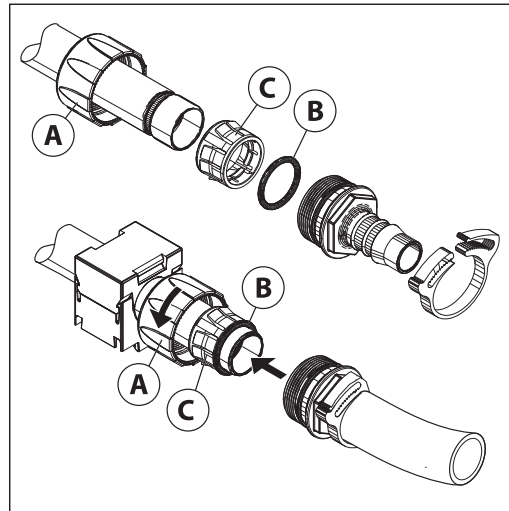

Initial Assembly of Fittings



ATTENTION! This method can only be used for pipes not fitted into pipe clamps.

1. Fit the barbed lock ring (C) to the feed pipe with barb pointing away from pipe opening.
2. Fit the oiled O-ring (B) onto the feed pipe next to the lock ring (C).
3. Screw the union nut (A) on the hose barb.
4. Press the feed pipe and hose barb together.
5. Tighten the union nut (A) by hand if needed.

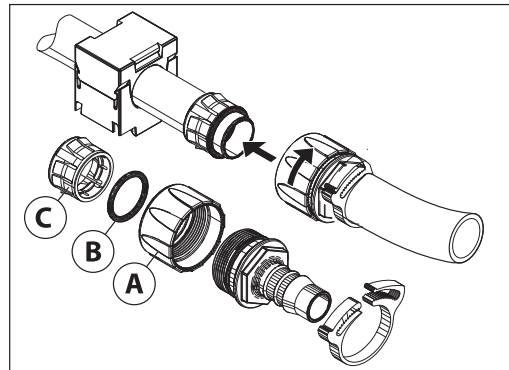

Nozzle Holder Assembly

If leaks of fluid occur in the nozzle holders on the spray boom, it is necessary to check the gaskets. The nozzle holder needs to be disassembled to locate the gaskets. Occasional maintenance of the gaskets and nozzle holders is recommended.

Poor seals are usually caused by:

- Missing O-rings
- Damaged or incorrectly seated O-rings
- Dry or deformed O-rings
- Foreign objects.

In Case of Leaks

1. Disassemble the pipe fitting.
2. Check condition and position of O-ring. Replace it if damaged or cracked.
3. Clean and lubricate the O-ring. Lubricate all the way around using a non-mineral lubricant.
4. Reassemble the O-ring or gasket and pipe fittings. When tightening the fittings, a little mechanical leverage may be used.

How To Disassemble Nozzle Holders

Nozzle holder assembled and mounted on the spray boom.



The black plastic parts are snapped together.

To disassemble, insert a slotted screwdriver (B), and press until the locking piece (A) snaps out.

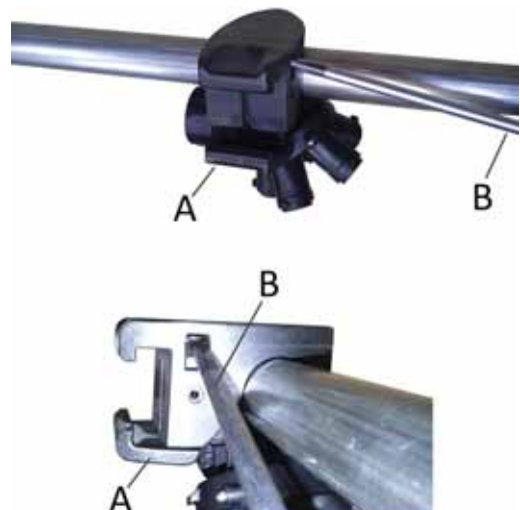

6 - Maintenance

With the locking piece (B) removed, place the screw driver as shown and pull to remove the upper part (C) of the nozzle holder.

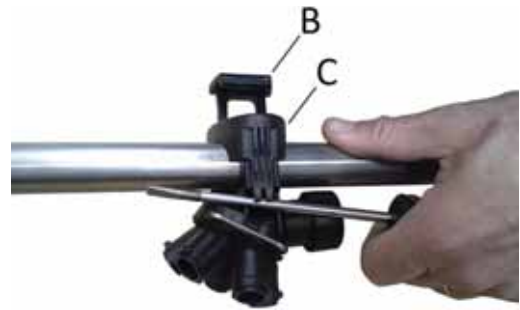

Locking piece (B) and upper part separated (C).



Inside the lower part (D), the O-ring (E) is located, and it can now be removed for maintenance.

Note that the O-ring, when seated, is supposed to be a little out of shape to fit tightly around the hole in the nozzle pipe.

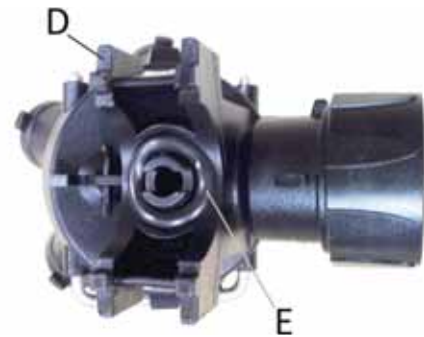

How To Reassemble Nozzle Holder

1. Place the O-ring inside the lower part.
2. Place the lower part on the nozzle pipe. The O-ring fits around the hole in the nozzle pipe, where the spray liquid exits to the nozzle holder.
3. Place the upper part on the opposite side of the nozzle pipe.
4. Click the parts together by pressing relatively hard.

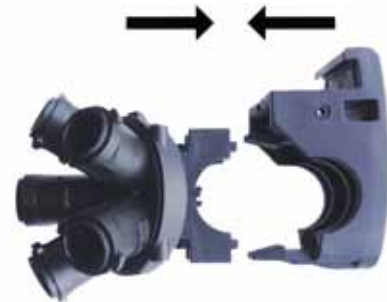

5. Insert the locking piece in the upper part to secure it on the spray boom.



Nozzle Pipe Assembly

If fluid leaks occur in the pipelines on the spray boom, it is necessary to check the gaskets. The pipe fittings need to be disassembled to locate the gaskets. Occasional maintenance of the gaskets and pipe assemblies is recommended.

Poor seals are usually caused by:

- Missing O-rings or gaskets
- Damaged or incorrectly seated O-rings
- Dry or deformed O-rings or gaskets
- Foreign objects.

In Case of Leaks

DO NOT over-tighten the pipe fitting. Follow this procedure instead:

1. Disassemble the pipe fitting.
2. Check condition and position of O-ring or gasket. Replace it if damaged or cracked.
3. Clean and lubricate the O-ring or gasket. Lubricate all the way around using a non-mineral lubricant.
4. Reassemble the O-ring or gasket and pipe fittings. When tightening the fittings, a little mechanical leverage may be used.

How To Disassemble Pipe Fittings

Pipe fittings assembled.



6 - Maintenance

Unscrew the connector (A) on the steel pipe.



Pull the nozzle pipe (B) away from the T-piece (C).

A lock ring (D) and an O-ring (E) is located at the end of the pipe.

The O-ring can now be removed from the pipe for maintenance.

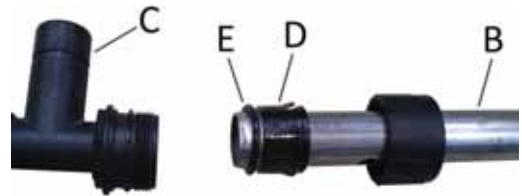

How To Reassemble Pipe Fittings

To reassemble the fittings, place the connector, lock ring and O-ring on the pipe in that order. Tighten the connector onto the T-piece.

Gasket Types

Usually an O-ring is used, but there is also a different type of gasket in use (F).



How To Remove Lock Ring

If the lock ring needs to be replaced, this can be done by mounting a connector (A) in reverse direction.



Push the connector over the lock ring.

Place the connector right behind the lock ring and pull to remove the lock ring from the pipe.



Adjustment of 3-Way Valve

The large ball valve (type S93) can be adjusted if it is too tight to operate or if it is too loose (= liquid leakage).

- Correct setting is when the valve can be operated smoothly by one hand.

Use a suitable tool and adjust the toothed ring inside the valve as shown on the drawing.



ATTENTION! The small ball valves (type S67) cannot be adjusted.

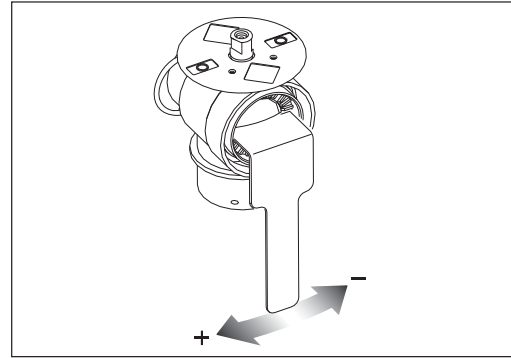

Safety Valve Activation

To make the fluid system work perfectly over time, it is good practice to regularly provoke opening of the safety valve.

This prevents clogging and ensures proper function of the safety valve. Opening of the valve is done by turning the pressure SmartValve to an unused function or "TurboFiller" (without activating it) when the pump is running. This is good practice for all sprayers; particularly for sprayers without optional equipment.

Readjustment of Boom - General Info

Before beginning boom adjustments, please go through this check list:

1. The sprayer must be well lubricated (see the section "Lubrication").
2. Connect the sprayer to the tractor.
3. Place tractor and sprayer on level and solid ground.
4. Activate parking brakes for tractor.
5. Put wedges under the wheels to prevent rolling.
6. Unfold the boom.
7. Place strong supports below the center section and all boom sections to relieve the load from the hydraulic cylinders.
If you have a lifting crane, support the center section as a minimum, as this is the heaviest boom part (up to 2200 lb or 1000 kg).
8. Set tilt angle of both wings to horizontal position.



DANGER! No one is allowed under the boom while the adjustment is carried out.

Adjustment of hydraulic cylinders is to be carried out without pressure in the system.



ATTENTION! For information on boom terminology, see "Spray Boom and Terminology" on page 37.

To check the boom alignment, you can use a bubble level, or you can measure the distance to the ground from similar points in both ends of the boom wing (this method is used for horizontal alignment and only on level ground). When using the latter method, both distances should be equal to obtain a horizontal boom.

Boom sections, which are not support during adjustment jobs, might fall down or be difficult to adjust.

Adjustments are to be completed equally for both right and left boom wings.

6 - Maintenance

Alignment of Center Section and Inner Wing

For boom widths of 80' - 100'.

The boom tip must point slightly forward. If necessary, adjust the inner wing as follows when unfolded:

1. De-pressurize the hydraulic folding cylinders.
2. Loosen jam nut (A).
3. Adjust stop screw (B) until the correct setting is reached.
4. Tighten jam nut again.

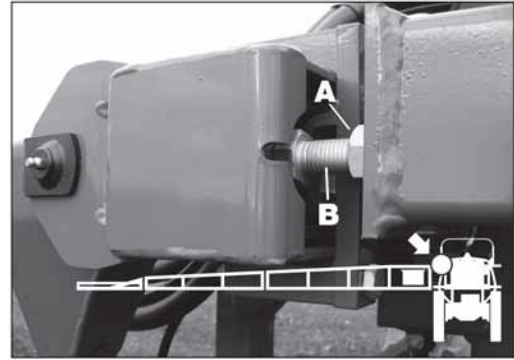

Adjustment of Boom Tilt

The horizontal adjustment of the boom wings is done by the retracted tilt cylinder. The boom must be straight and horizontal. If necessary, adjust the wing as follows:

1. Support the boom wing with jack stands or similar to relieve the load from the hydraulic cylinder.
2. Loosen the jam nut (A), which is positioned by the hinge ring on the cylinder's piston rod.
3. Adjust the cylinder ram inwards or outwards (using a wrench on the two flattened sides on the end of the ram) to get the desired level for the boom wing.

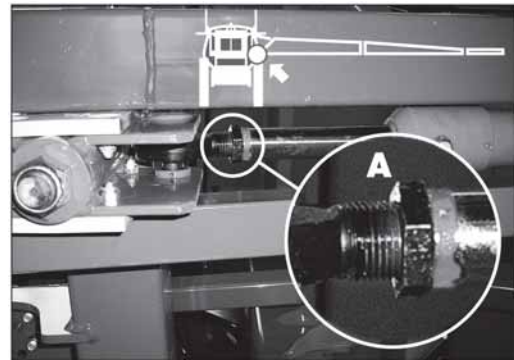

Adjustment of Boom Wings (Boom Width: 120')

Preparations

Park the tractor and sprayer.

Unfold the spray boom.

Before adjusting the boom, tighten all bolts and nuts at the hinge points.

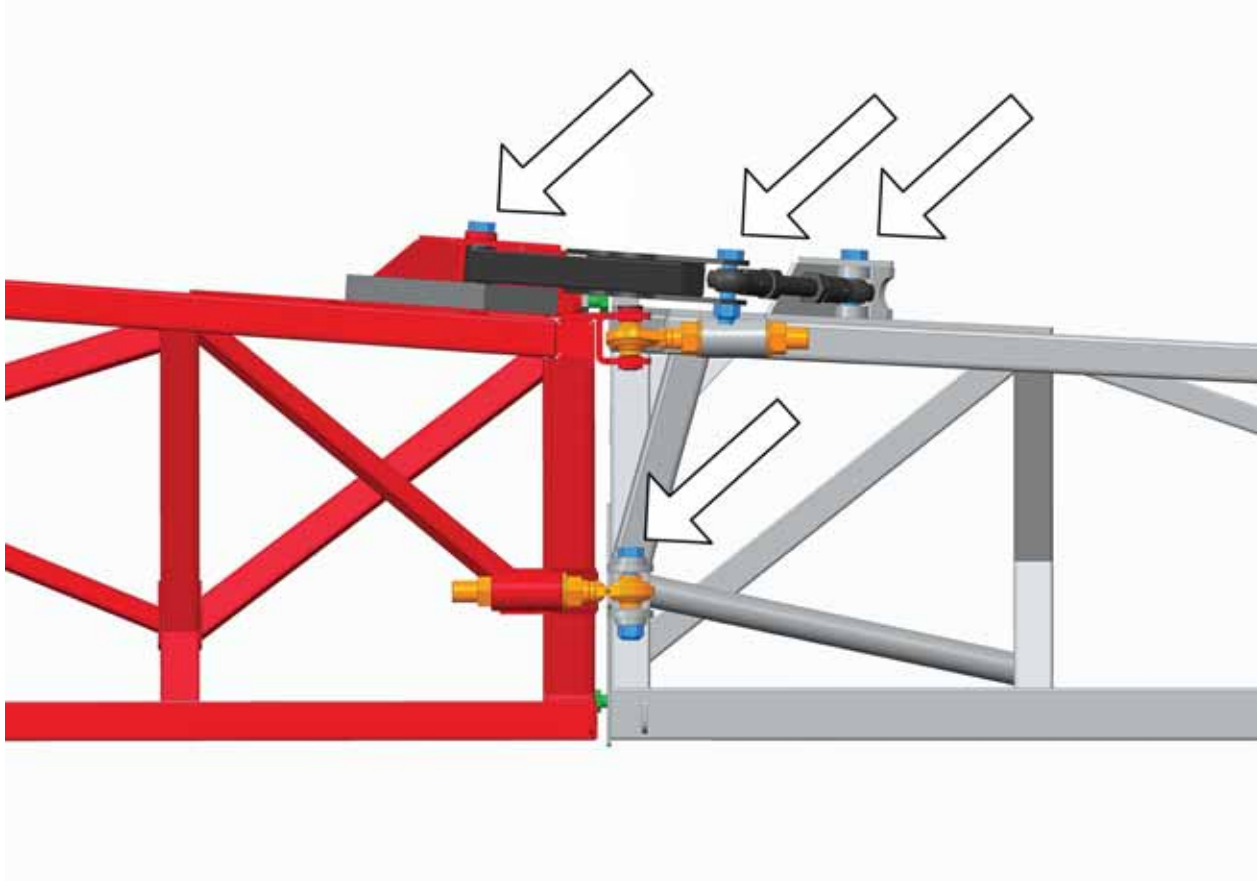

Tools Needed

Size: 13 - 17 - 27 - 30 - 38 - 46 mm.



Some adjustments may require an extension on the wrench to achieve the proper torque.

6 - Maintenance

Procedure

1. Remove the bolt, nut and washers connecting the hydraulic cylinder to the hinge point.
Disconnect the hydraulic cylinder and move it away from the hinge point.



2. The aluminum boom part is aligned horizontally by adjusting the two M34 ram eyes.
Use a bubble level to check the alignment.
Once the boom is aligned horizontally, tighten the M34 nuts just slightly.

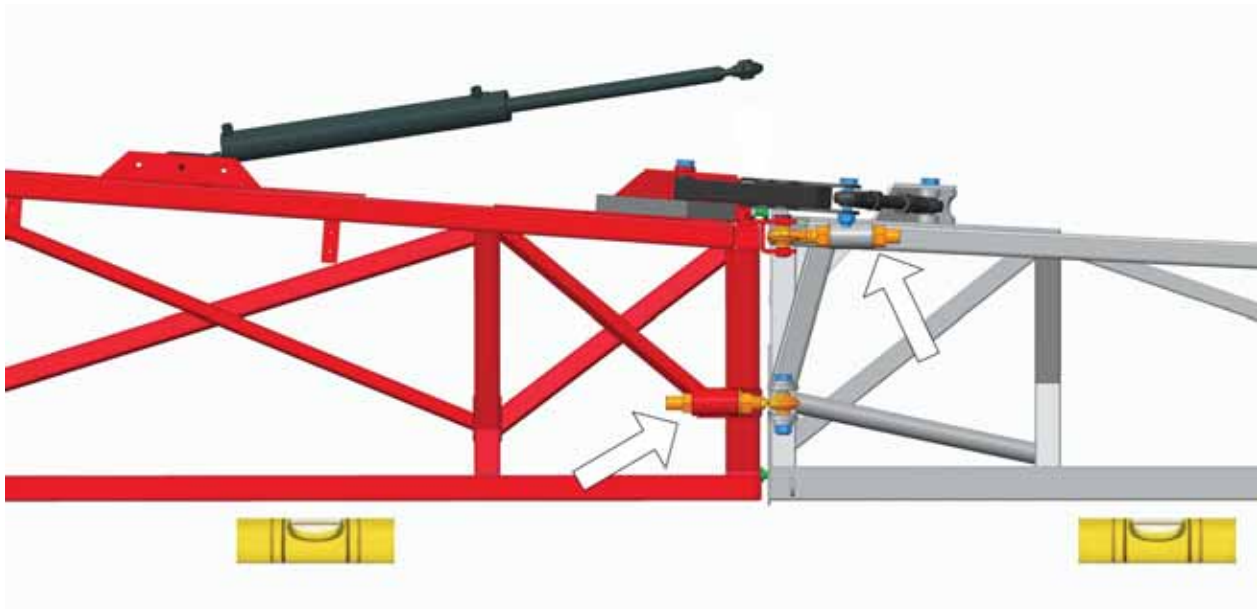

At the same time, adjust the two stop bolts to align the boom sections.

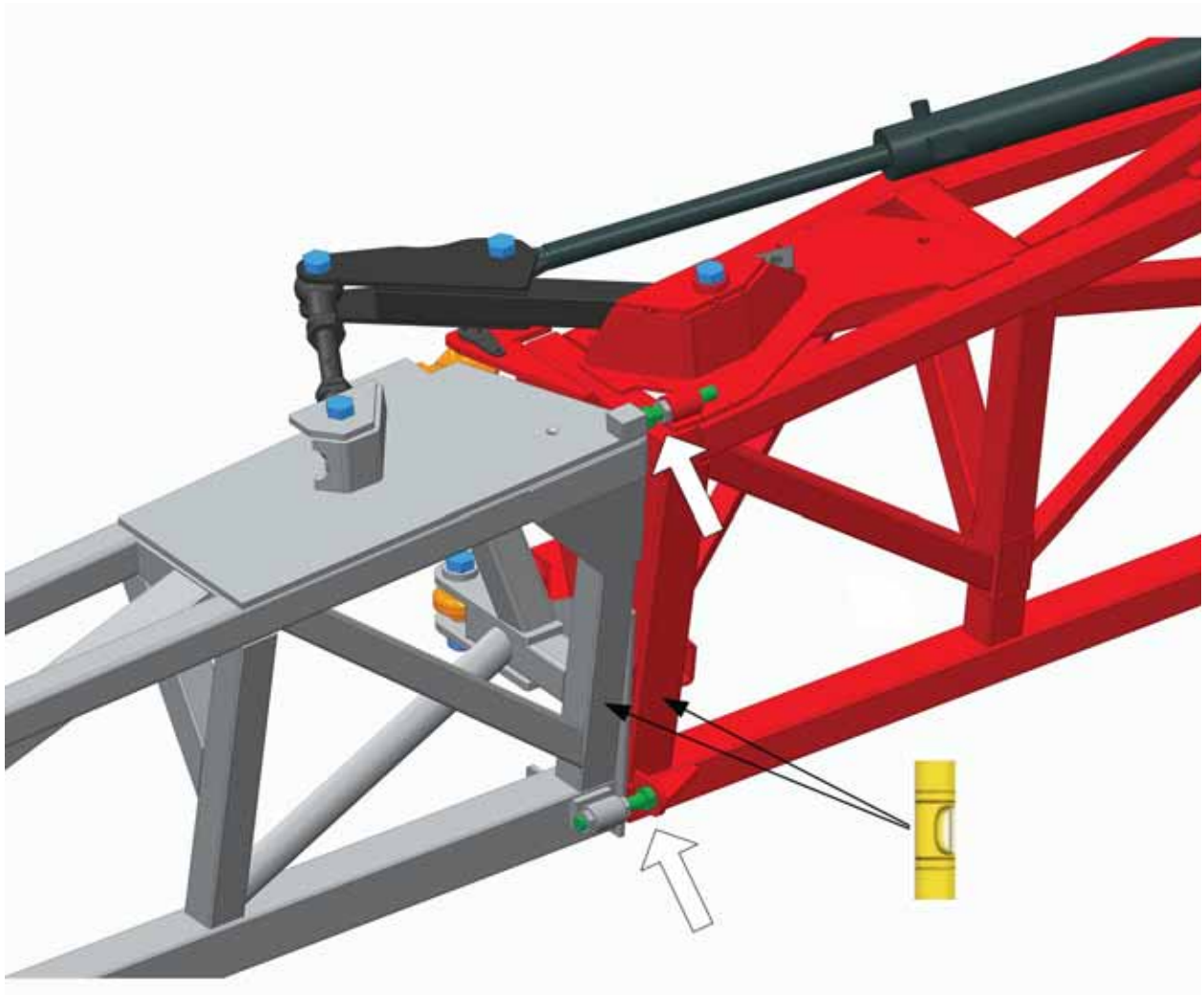

6 - Maintenance

3. Fold the aluminum boom by hand.
 - Check the horizontal alignment at the base.

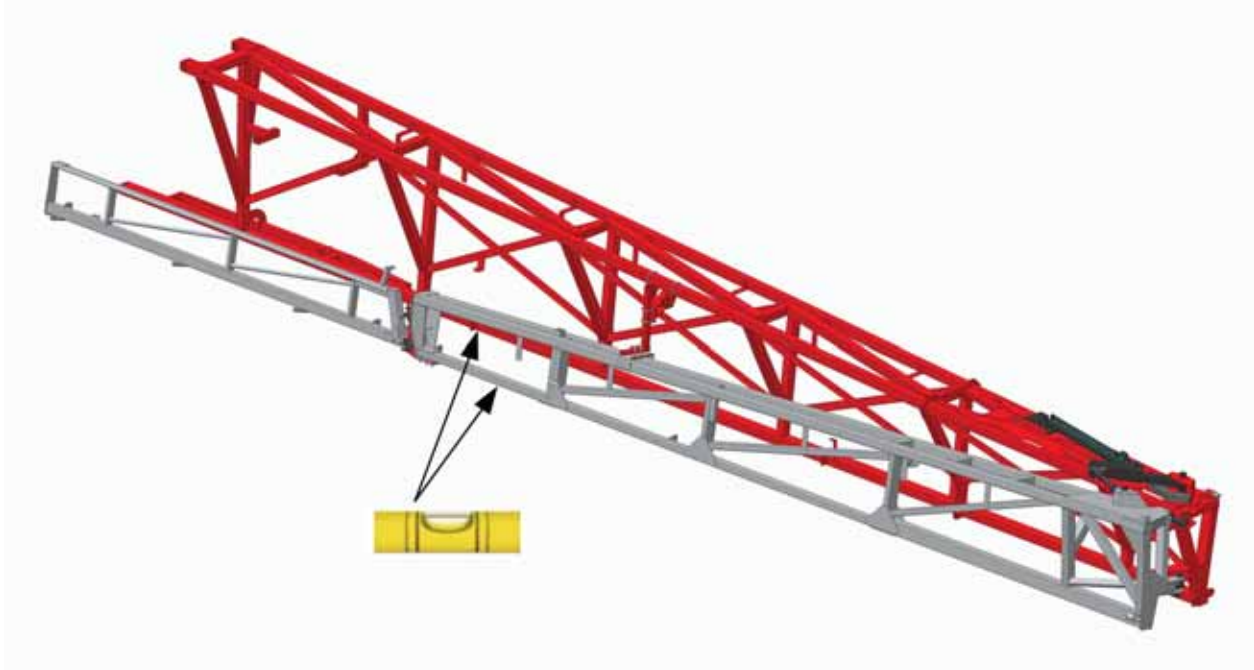

4. If the aluminum boom sits too HIGH or too LOW in relation to the steel boom when folded, unfold the aluminum boom once again.
Keep the horizontal settings, and adjust the M34 ram eyes (A and B) to raise or lower the aluminum boom.

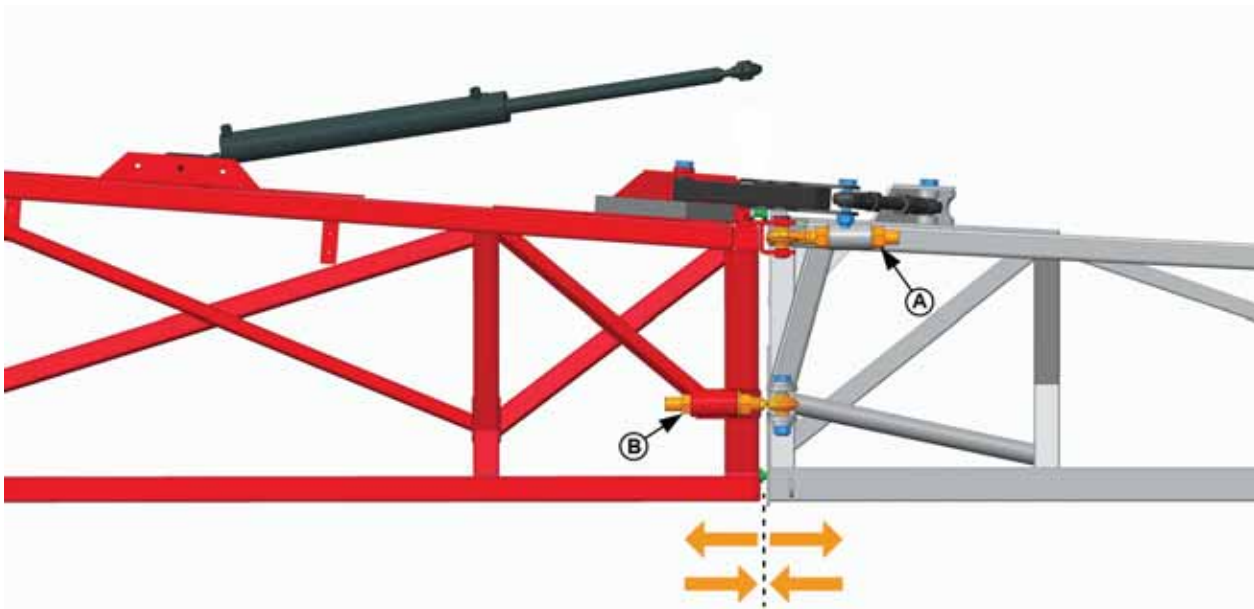

- To lower the aluminum boom, adjust A and B outwards the same length, e.g. same number of nut revolutions.
- To raise the aluminum boom, adjust A and B inwards the same length.

6 - Maintenance

5. Fold the aluminum boom once again and check the alignment with the steel boom.
 - If there is a misalignment, unfold the boom and readjust the M34 ram eyes if needed.

6. When the alignment is identical, adjust the bracket to support the aluminum boom during transport.
 - Loosen the nuts on the braces to move the bracket up or down. Fit it into the braces on the aluminum boom.
 - Tighten the nuts when the bracket is in place.



7. Unfold the boom one last time to tighten the M34 nuts on the double ram eyes.
 - Tighten the M34 nuts to 443 Ft/lb (600 Nm). Use an extension on the wrench if necessary.

6 - Maintenance

8. Fine tune the stop bolts (C and D) and check the boom alignment.

- Stop D should be touching the steel boom.
- A gap of 1-2 mm should be present between Stop C and the aluminum boom.

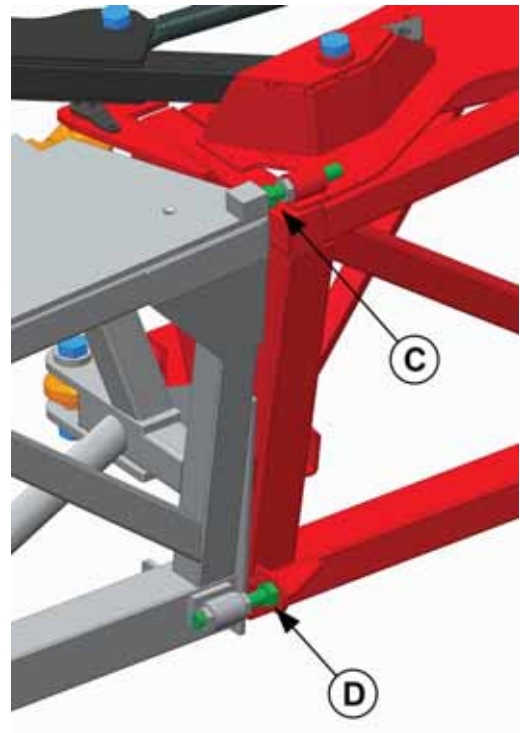

9. Connect the hydraulic cylinder and tighten the bolt and nut firmly.

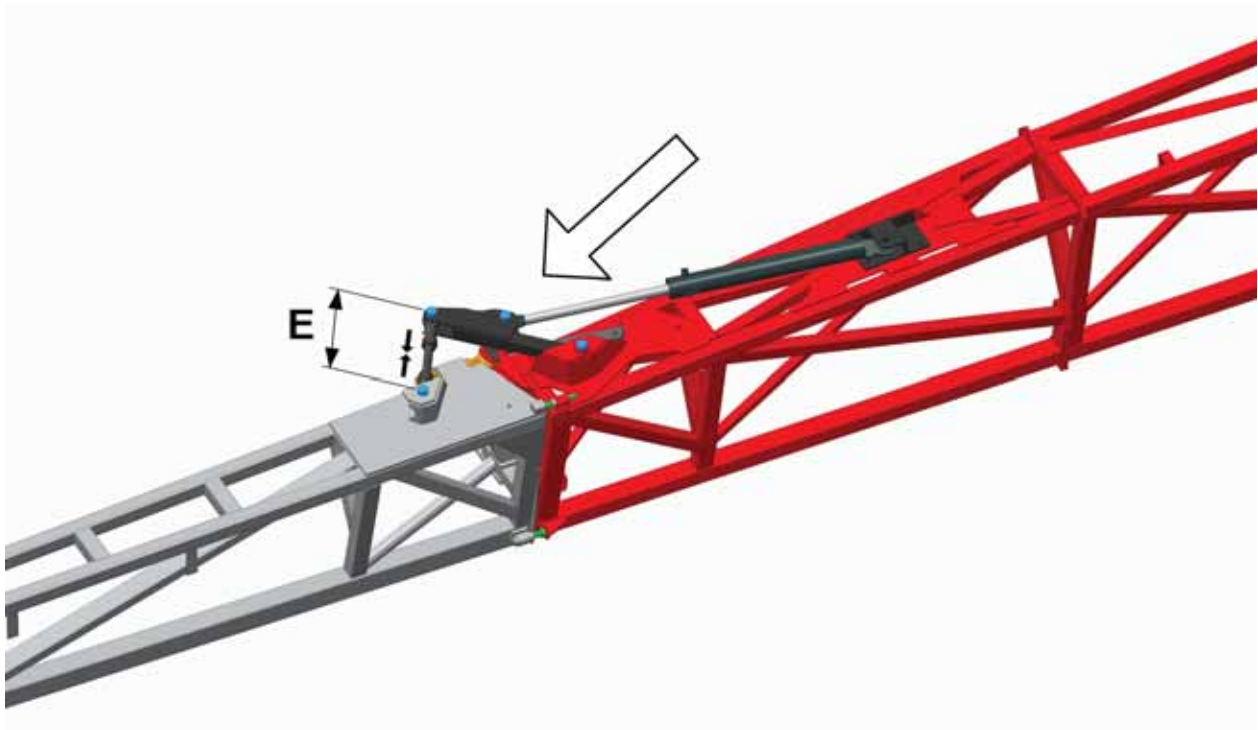

10. Minimize the distance E as much as possible by turning the rod on the double ram eye. Loosen the nuts and turn the rod with a wrench.

11. Fully extract the hydraulic cylinder by applying hydraulic pressure.
 - Now increase the distance E by turning the rod the opposite way, until Stop D is touching the steel boom.
 - Keep the gap of 1-2 mm between Stop C and the aluminum boom.

12. Continue to increase the distance E, until stop C is touching the aluminum boom.
 - Keep the hydraulic cylinder fully extracted - it must not retract when adjusting the double ram eye.
 - Keep turning the ram eye rod 3 turns.
 - Tighten the nuts on the ram eye rod with a wrench with extension.

13. The force of the hydraulic cylinder can cause misalignment of the boom.

If needed, adjust Stop C and D once more to touch the opposite boom section.

14. With the boom perfectly straight, now tighten the nuts firmly on Stops C and D and on the double ram eye.

6 - Maintenance

Adjustment of Breakaway Section

Connection Type: Claw clutch

The breakaway section must release when a force of approximately 33 lb (15 kg) is applied to the end of the breakaway section. If necessary, the release force is adjusted as follows:

1. Make sure that claw coupling is correctly lubricated.
2. Loosen the jam nut (A).
3. Adjust the nut (B) until the breakaway will release when a force of 33 lb (15 kg) applied at the end.
4. Tighten the jam nut again.



DANGER! Never place fingers into open breakaway clutch! Risk of injury if the clutch closes accidentally.



WARNING! Do not tighten the breakaway clutch more than what is described above. Risk of damage to the boom when the breakaway is activated.

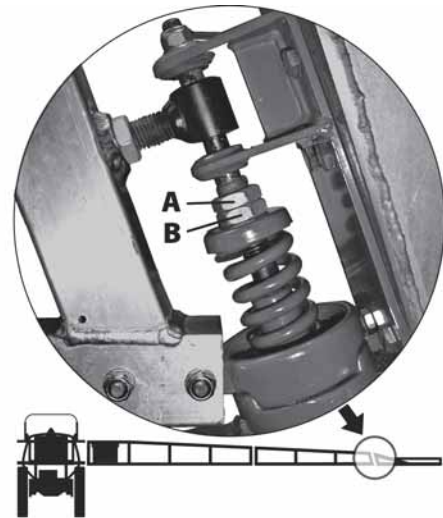

Connection Type: Spring

- The tension for the spring-loaded breakaway is adjusted by turning the nuts marked by the arrow.

Factory setting:

- Connect the spring in its relaxed state (no tension).
- Pull the spring out 4" (100 mm).



Yaw Damping

The unfolded spray boom will create yaw movements when:

- driving over uneven terrain
- turning on headland
- speeding up
- braking.

The three accumulators located in the boom center act as dampers for the yaw movements when driving in the field.

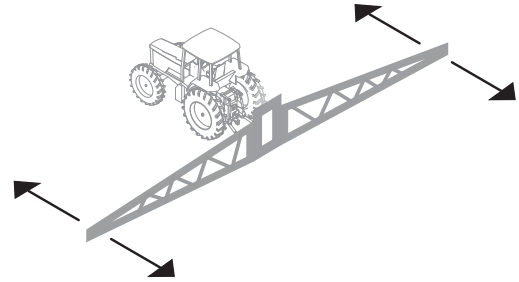

Damping Function

Each accumulator contains nitrogen gas and hydraulic oil, separated by a diaphragm. When the boom makes a yaw movement, hydraulic oil will be transferred into the accumulator. The oil pushes the diaphragm while compressing the gas. When this compression overcomes the oil pressure from the boom, the boom wing is moved back to its original position dampened by the oil flow in the circuit.

Accumulator Service

If the yaw damping seems to be insufficient, the accumulators need to be recharged or replaced. Ask your HARDI® dealer to assist you.

1. Check for any leaks.
2. Check pressure setting for the accumulators in the test sockets, which are located in the hydraulic block (A). Hydraulic hoses for the accumulators are also connected to this block.
3. Fill nitrogen gas (N₂) into the accumulators:
Gas pressure = 435 psi -0/+30 (30 bar -0/+2) for 120' booms.
The gas volume in the accumulator is approx. 0.5 liters.
4. Fill hydraulic oil into the accumulators:
Oil pressure = 870 psi -0/+30 (60 bar -0/+2) for 120' booms.



DANGER! Do not fill the accumulators with other gases, such as air or pure oxygen. Risk of explosion.



ATTENTION! The accumulators are automatically pressurized at 508 psi (35 bar), when the boom is unfolded.

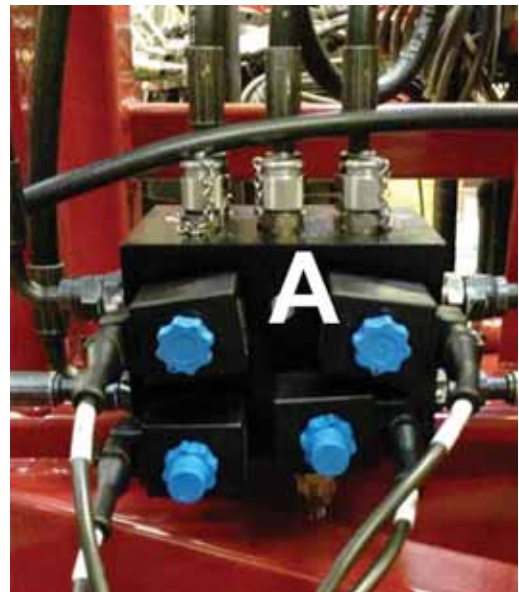

6 - Maintenance

Hydraulic Block for Yaw

| Item | Port on hydraulic block |
|----------------------------------|-------------------------|
| Hydraulic hoses for accumulators | ACC1, ACC2, ACC3 |
| Test sockets for accumulators | MACC1, MACC2, MACC3, TM |
| Yaw cylinders on spray boom | C1, C2, C3 |
| Return oil back to tractor | T |

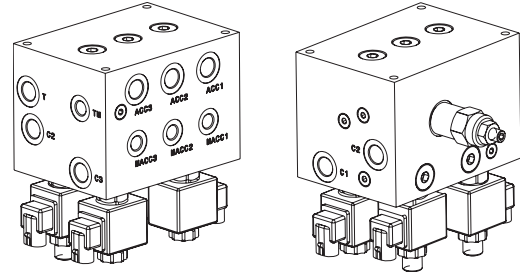

NOTE! For more details, see the section “Hydraulic Diagrams” on page 157 in the “Technical Specifications” chapter in this book.

Wear Bushing Replacement on Boom Lift

Inspect and replace the wear bushings before they are worn through.

1. Connect the trailer to a tractor and unfold the boom to working position.
2. Lift the boom center frame with a lifting device and support it, until the load is taken off the parallelogram arms.
3. Remove the screws (A), and pull out the pins (B) at one of the upper parallelogram arms and replace the wear bushes.
4. Replace the arm.
5. Repeat this procedure for the other upper arm.
6. The lower arms must be disconnected simultaneously.
7. Apply grease into all grease nipples.
8. Remove the lifting gear again.

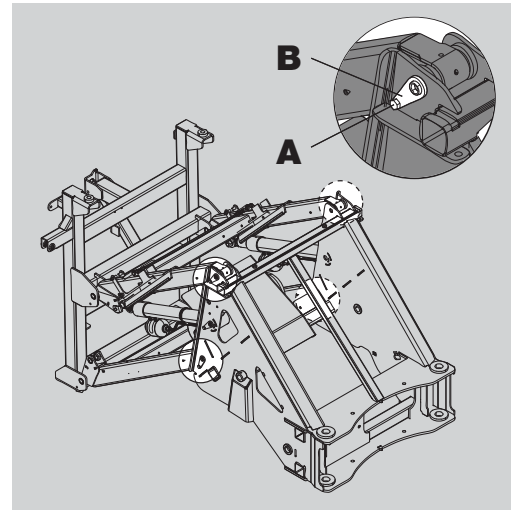

Wear Bushing Replacement on Steering

If too much play is found in the steering, the wear bushings must be replaced.

This should be done at your local HARDI® dealer.

Replacement of Transmission Shaft Shield

- See the manufacturer’s instruction book.

Replacement of Transmission Shaft Cross Journals

- See the manufacturer’s instruction book.

Change of Light Bulb

1. Switch off the light.
2. Loosen the screws on the lamp and remove the cover or lens.
3. Remove the bulb.
4. Fit a new bulb, replace the cover and tighten the screws.



ATTENTION! If halogen bulbs are used, never touch the bulb with your fingers. Natural moisture on the skin will cause the bulb to burn out when the light is switched on. Always use a clean cloth or tissue when handling halogen bulbs.

Change of Tire



DANGER! If it is time to change tires, it is recommended to leave this job to a specialist and follow the rules below. Some mounting instructions are usually printed on the tire itself.

Failure to understand the mounting instructions will result in a bad seating of the tire on the rim, and it could cause the tire to burst leading to serious injury or death!

Never mount or use damaged tires or rims! Use of a damaged, ruptured, distorted, welded or brazed rim is not allowed!

Mounting Instructions

- Always clean and inspect the rim before mounting a new tire.
- Always check that the rim diameter corresponds exactly to the rim diameter molded on the tire.
- Always inspect the tire inside for cuts, penetrating objects or other damages. Repairable damages should be repaired before installing the tube. Tires with non-repairable damages must never be used.
- Always inspect the tire inside for dirt or foreign objects. Remove this before installing a new tire tube.
- Always use new tubes of recommended size. When fitting new tires, always fit new tubes. Do not use tubes for tubeless tires.
- Before mounting, always lubricate both tire beads and rim flange with approved lubricating agent or equivalent anti-corrosion lubricant. Never use petroleum based greases and oils, because they may damage the tire. Using the appropriate lubricant will prevent the tire from slipping on the rim.
- Always use specialized tools for mounting the tires as recommended by the tire supplier.
- Make sure that the tire is centered, and that the beads are perfectly seated on the rim - otherwise tearing of the bead wire may occur.
- Inflate the tire to 14.5-19 psi (1-1.3 bar), then check whether both beads are seated perfectly on the rim. If any of the beads do not seat correctly, deflate the assembly and re-center the beads, before starting inflation of the tire.
If the beads are seated correctly on the rim at 14.5-19 psi (1-1.3 bar), inflate the tire to a maximum of 36 psi (2.5 bar) until they seat perfectly on the rim.
- Never exceed the maximum mounting pressure molded on the tire!
- After mounting the tires, adjust the inflation pressure to the operation pressure as recommended.

6 - Maintenance

Venting the Boom Hydraulics

If the hydraulic cylinders or hoses have been dismantled, it is necessary to vent the cylinders after reassembly.



DANGER! Failing to vent the hydraulic system when needed may result in violent boom movements and poor boom performance. Risk of damage to the boom parts or foreign objects nearby. Risk of severe injuries or death.



ATTENTION! Not all hydraulic cylinders have a venting option. In this case you must loosen the hydraulic hose connected to the cylinder to let the air out this way. Note that ORFS fittings are used - be careful not to damage the sealing O-ring, when venting oil.



ATTENTION! The following venting instructions are for double acting cylinders only. For single acting cylinders, such as for the boom tilt motion, the venting is easily completed: After service, apply hydraulic pressure to the cylinder, retract and extend the piston approx. 5 times, and the air is then removed from the system automatically.

Sequence For Venting of Cylinders

To complete an efficient venting of air in the system, this sequence should be followed.

1. Boom center: Cylinders for inner sections on boom wings.
2. Boom wings: Cylinders for outer sections 1.
3. Boom wings: Cylinders for outer sections 2.

Venting Procedure

Follow these steps to complete the venting. Both venting screws or valves (A and B) are closed to begin with.

1. Cylinder piston is retracted.
2. Remove the dust caps from the venting valves.
3. Mount a clear 5 mm hose to the venting valve (A) and lead it into a suitable container.
4. Open the venting valve (A).
5. Activate the hydraulic oil pressure and extend the piston fully.
6. Close the venting valve (A) and remove the hose.
7. Mount the clear hose to the other venting valve (B).
8. Open the venting valve (B).
9. Activate the hydraulic oil pressure and retract the piston fully.
10. Close the venting valve (B) and remove the hose.
11. Repeat steps 3 - 10 a few times until air is no longer visible in the hose.
12. Replace the dust caps. Venting is completed for this cylinder.
13. Check your hydraulic oil level - top up if needed.

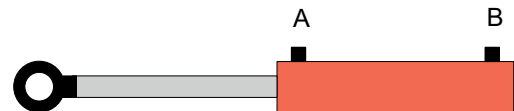
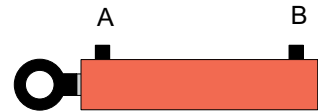

DANGER! Be careful when operating the cylinders. Make sure that no unauthorized persons are in the working area, when folding or unfolding the boom! When retracting the pistons into the cylinders, keep fingers, tools and clothes away from the piston. Risk of getting trapped between moving boom parts or folded boom sections resulting in severe injuries or death.



ATTENTION! Depending on the boom design, it might be more practical to begin with the cylinder extended.



ATTENTION! A helping hand is useful to complete the venting procedure.

TWIN System, Priming of Blower Transmission

If the hydraulic blower transmission has been dismantled, or the pump or the motor has been changed, the following priming procedure must be carried out before starting up the transmission:

1. Fill the oil tank with fresh, clean oil to the top of the sight glass.
2. Fill the pump housing with oil through the drain pipe (D) which is dismantled at the tank connection. Reconnect and tighten.
3. Ensure that the oil level in the gear box is sufficient.
4. Remove the drain hose (D) from the motor outside the blower housing.
5. In the tractor cabin, set the blower speed at 0 rpm.

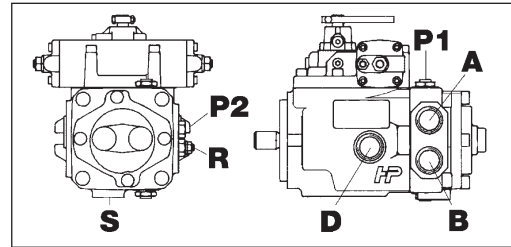

Engage the tractor's PTO with the engine running idle - and wait a few minutes.

6. Set the blower speed at 200 rpm.
7. After a while the oil will start dripping constantly. Replace the drain hose and tighten.
8. With the tractor's PTO set at 1000 rpm, the blower should now rotate at maximum speed (3100 rpm).
9. Check the oil level at the sight glass for the hydraulic tank on the sprayer.
10. Check the pressure gauge for the suction filter (indicator is in the green area).
11. Re-tighten hose connections and check for leaks.
12. Check the blower speed and feed pressure - see below.

Pressure Adjustment of Blower Transmission

Ports and connectors for blower transmission:

| | |
|----|---|
| A | = Pressure port |
| B | = Return port |
| D | = Drain port |
| P1 | = Connector for measurement of working pressure |
| P2 | = Connector for feed pressure |
| R | = Adjustment screw for feed pressure |
| S | = Suction port |

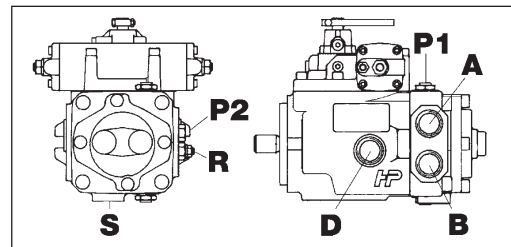

The transmission feed and working pressure are checked as follows:

1. P1 connector - working pressure: Connect a pressure gauge (0 - 5800 psi) or (0 - 400 bar).
P2 connector - feed pressure: Connect a pressure gauge (0 - 580 psi) or (0 - 40 bar).
2. Set the tractor's PTO at 1000 rpm.
3. Set the blower at maximum speed (3100 rpm).
4. Check the feed and working pressure:
Feed pressure P2: 220-290 psi (15-20 bar)

| | | | | |
|---------------------|--------------------|--------------------|--------------------|--------------------|
| Boom width | 80' (24 m) | 90' (27 m) | 100' (30 m) | 120' (36 m) |
| Working pressure P1 | 3480 psi (240 bar) | 3480 psi (240 bar) | 3480 psi (240 bar) | 3480 psi (240 bar) |

5. Adjust feed pressure (R) if needed.



ATTENTION! Failure to reach the feed and working pressure indicates that the transmission needs overhauling.

6 - Maintenance

Off-Season Storage

General Info

To preserve the sprayer intact and to protect its components, carry out the following off-season storage program.

Before Storage

When the spraying season is over, you should devote some extra time to the sprayer. If chemical residues are left over in the sprayer for longer periods, it may reduce the life of its individual components.

1. Clean the sprayer completely - inside and outside - as described under "Cleaning" on page 86. Make sure that all valves, hoses and auxiliary equipment have been cleaned with a cleaning agent and flushed with clean water afterwards, so that no chemical residues are left in the sprayer.
2. Replace any damaged seals and repair any leaks.
3. Empty the sprayer completely, and let the pump work for a few minutes. Operate all valves and handles to drain as much water out of the liquid system as possible. Let the pump run until air comes out of all nozzles. Remember to drain the rinsing tank also.
4. Protection against frost:

First complete the cleaning inside and outside the sprayer.

Pour approximately 13 gal. (50 liters) of antifreeze mixture into the main tank. In the mixture, include any remaining water in the liquid system to create a protective ratio of antifreeze/water solution.

Depending on your winter temperatures, use the recommended mixture ratio in the table below:

| % Water / Antifreeze | Freezing Point |
|----------------------|-----------------|
| 90% | 26° F (-3° C) |
| 80% | 18° F (-8° C) |
| 70% | 7° F (-14° C) |
| 60% | -10° F (-23° C) |
| 50% | -34° F (-37° C) |

Turn on the pump and operate all valves and functions, operating units, TurboFiller etc., allowing the antifreeze mixture to be distributed around the entire liquid system without leaving any unmixed water in hidden places.

Unmixed water will freeze and possibly damage the sprayer's components!

Open the operating unit main valve ON/OFF and distribution valves, so that the antifreeze is sprayed through the nozzles as well. The antifreeze will also prevent O-rings, seals, diaphragms etc. from drying out.

The FlexCapacity pump (if equipped) must also be engaged and flushed.

Empty filters and boom pipes. Remember to unscrew the end plugs, as unmixed water can build up in blind pipe ends causing a risk of a broken end plug or pipe, when the boom pipes are pressurized at the next spray job.

5. Remove the glycerine-filled pressure gauges and store them frost-free in a vertical position.

Also dismantle the sensor (A) connected to the nozzle pressure gauge after filling the antifreeze mixture, as this area is a possible blind end that could result in frost damages.

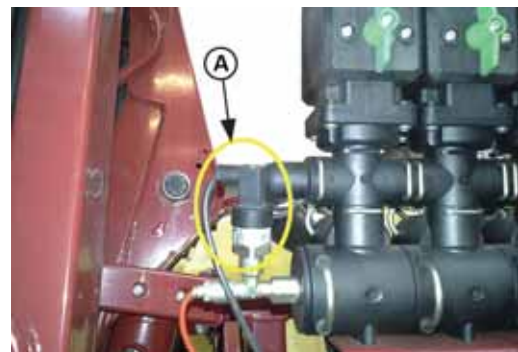

6. Lubricate all lubricating points according to the lubricating intervals.

7. When the sprayer is dry, remove rust from scratches or damage in the paint, if any, and touch up the paint.
8. Apply a thin layer of anti-corrosion oil (e.g. SHELL ENSIS FLUID, CASTROL RUSTILO or similar) on all metal parts. Avoid oil on rubber parts, hoses and tires.
9. Fold the boom into transport position and relieve pressure from all hydraulic functions.
10. All dismantled electric plugs and sockets are to be stored in a dry plastic bag to protect them against moisture, dirt and corrosion.
11. Remove the control boxes and computer display from the tractor. Store them dry and clean (inside). A non-condensing environment is recommended.
12. Wipe hydraulic snap couplers clean and fit the dust caps.
13. Apply grease to all hydraulic ram piston rods, which are not fully retracted in the housing to protect against corrosion.
14. Chock the wheels to prevent moisture damage and deformation of the tires. Tire blacking can be applied to the tire walls to preserve the rubber.
15. To protect against dust, the sprayer can be covered by a tarpaulin. Ensure ventilation to prevent condensation.

After Storage

After a storage period, the sprayer should be prepared for the next season the following way:

1. Remove the tarpaulin.
2. Remove the support for the wheel axle, and adjust the tire pressure.
3. Wipe off the grease from hydraulic ram piston rods.
4. Fit the pressure gauges again. Seal with Teflon tape or similar.
5. Connect the sprayer to the tractor, including pneumatic, hydraulic, electric and electronic connections. Check that the hoses and cables are free to move along when driving with the sprayer. No rubbing or stretching of cables and hoses.
6. Check that hydraulic hoses are connected correctly to tractor (see flow directions marked on the hoses), and they are without damages.
7. Check that electric cables to the tractor are intact and connected correctly, cable sheaths are without damage from wear, stretching or rubbing. Check electric plugs are without corrosion or damages, electric boxes are without cracks.
8. Check that PTO shaft is connected correctly to the tractor, and protection guards are in good working order. See the delivered instruction manual for the PTO for more about correct installation.
9. Drain antifreeze mixture from the tank and spray boom.
10. Fill with clean water and check all functions. Liquid test: Fill a small amount of water in the tank and circulate it through the liquid system. Spray pressure = 70psi (5 bar). Repair leaks, if any. Check spray patterns and water jets from nozzles.
11. Rinse the entire liquid circuit of the sprayer with clean water.
12. Check that the main tank is clean inside and close the drain valve.
13. Check that traffic lights are visible and in good working order, protection glasses are clean and without damages.
14. Check all electric functions.
15. Check that the spray boom folds correctly - make adjustments if needed. Repair oil leaks if any. Check that hydraulic hoses and electric cables are in place, and that they follow the folding movements without being damaged.
16. Check that speed sensor and other sensors are in good condition and free of dirt.

Operational Problems

General Info



DANGER! Specialized persons should be involved in fault finding as this is hazardous work! It might be necessary to have the sprayer operating to complete the fault finding.

Operational incidents are often due to the same reasons:

- A suction leakage reduces the pump pressure and may interrupt suction completely.
- A clogged suction filter may damage suction or interrupt and prevent the pump from running normally.
- A clogged pressure filter increases pressure in the fluid system in front of the pressure filter. This may blow the safety valve.
- Clogged in-line filters or nozzle filters increase pressure in the pressure gauge, but it decreases pressure at the nozzles.
- Impurities sucked in by the pump may prevent the valves from closing correctly, thus reducing the pump flow.
- A bad reassembly of the pump elements, especially the diaphragm covers, causes air intakes or leaks and reduces the pump flow.
- Rusted or dirty hydraulic components cause bad connections and early wears.
- A poorly charged or faulty battery causes failure and misbehavior in the electrical system.

Therefore ALWAYS check that

- Suction and pressure filters, as well as nozzles, are clean.
- Hoses are free of leaks and cracks, especially suction hoses.
- Gaskets and O-rings are present and in good condition.
- Pressure gauges are in good working order. Dosage accuracy depends on it.
- Operating unit functions properly. Use clean water to check.
- Hydraulic components are clean.
- The tractor battery and its connectors are in good condition.

7 - Fault Finding

Liquid System

| FAULT | PROBABLE CAUSE | CONTROL / REMEDY |
|---|---|--|
| No spray from boom when turned on. | SmartValve / Pressure valve positions are wrong. Suction/pressure filters are clogged. No suction from tank. | Set correct valve positions for spraying. Clean suction and pressure filters. See if suction fitting in main tank sump is free of sedimentation. Clean if needed. |
| Lack of pressure. | Incorrect assembly. Air in system. Too much agitation. Pump valves are blocked or worn. Blocked filters. Defective pressure gauge. | Boost valve has a defect (it is located at the bottom of the pressure filter). The valve seat is worn or missing. Fill suction hose with water for initial priming. Close the agitation valve. Check for obstructions and wear. Clean all filters. Check for dirt at inlet of pressure gauge. |
| Pressure dropping. | Filters are clogging. Nozzles are worn. Sucking air towards end of tank load. | Clean all filters. Fill with cleaner water. If using powders, make sure agitation is on. Check nozzle output. Replace nozzles, if the deviation in output exceeds 10%. Lower pump speed (rpm). |
| Pressure increasing. | Pressure filters beginning to clog. | Clean all filters. |
| Formation of foam. | Air is being sucked into system. Excessive liquid agitation. | Check tightness / gaskets / O-rings of all fittings on suction side. Lower pump speed (rpm). Check safety valve is tight. Ensure returns inside the tank are present. Use a foam damping additive. |
| Operating unit is not functioning, or it is having a malfunction. | Blown fuse(s). Wrong polarity. Valves not closing properly. No power. | Check mechanical function of micro switches. Use cleaning/lubricating agent if the switch does not operate freely. Check motor current, max. 450-500 mA. If over, change the motor. Brown to positive (+). Blue to negative (-). Check valve seals for obstructions. Check micro switch plate position. Loosen the screws holding the plate a 1/2 turn. Wrong polarity. Check that brown is positive (+), blue is negative (-). Check print plate for dry solders or loose connections. Check fuse holder is tight around fuse. |

7 - Fault Finding

| FAULT | PROBABLE CAUSE | CONTROL / REMEDY |
|---|---|---|
| Pump | | |
| Liquid leaks from the bottom of the pump. | Damaged diaphragm. | Replace diaphragm. |
| Grease leaks from the bottom of the pump. | Grease used has too low viscosity. | Change to recommended grease type. |
| Grease leaks from the shaft grease seals. | Grease used has too low viscosity. Bearings worn/too high friction. | Change to recommended grease type. Replace pump bearings and grease seals. |
| Lack of pressure. | Pump valves are blocked or defective. Plugged filters in fluid system. | Check for obstructions or, if needed, replace valves. Clean filters. |
| Vibrations in system and unpleasant noise from the pump. | Pump valves are blocked or defective. Air is being sucked into system. | Check for obstructions or, if needed, replace valves. Check for leaks, pinholes in suction hoses, tightness / gaskets / O-rings of all fittings on the suction side. |
| Lack of flow / capacity. | Internal wear on conrod and conrod ring. Pump valves are blocked or defective. | Poor greasing. Replace parts as needed and observe proper grease quality and intervals. Check for obstructions or, if needed, replace valves. |
| Extreme internal erosion on diaphragm covers and housing. | Too high vacuum caused by clogged suction filter or excessive pump speed (rpm). Lack of internal cleaning. Lack of conservation of the fluid system during storage. | Replace affected pump parts. Clean suction filter and observe maximum pump speed (rpm). Use recommended cleaning procedures and add extra cleaning agents (e.g. AllClearExtra or similar). Always use a proper mixture of antifreeze during storage. |
| Short lifetime for diaphragm. | Overspeeding of the pump. | Observe maximum pump speed (rpm). |

7 - Fault Finding

Hydraulic System, Z-version

| FAULT | PROBABLE CAUSE | CONTROL / REMEDY |
|---|--|---|
| No boom movements when activated. | <p>Insufficient hydraulic pressure.</p> <p>Insufficient oil supply.</p> <p>The operator has interrupted the boom folding by releasing the folding button in the tractor for more than 30 seconds. A built-in timer automatically removes the oil pressure in the yaw dampers 30 seconds after activating a folding button.</p> <p>Blown fuse(s).</p> <p>Bad / corroded electrical connections.</p> <p>Insufficient power supply.</p> <p>Defective relay / diodes in junction box.</p> <p>Clogged restrictors in bypass block.</p> <p>Wrong polarity.</p> | <p>Check oil pressure.</p> <p>Check tractor hydraulic oil level.</p> <p>Oil flow must be 7-24 gal/min (depending on the equipment on the sprayer).</p> <p>Check tractor hydraulic oil level.</p> <p>Unfold the boom completely. Start folding again without letting go of the activated folding buttons for more than 30 seconds at a time, until the folding is completed.</p> <p>Check / replace fuse in junction box.</p> <p>Check / clean connections, multi plugs etc.</p> <p>Voltage on activated solenoid valve must be more than 8 volts.</p> <p>Use wires of at least 10 awg. for power supply.</p> <p>Check relays, diodes and soldering at PCB in junction box. LED diodes indicate boom functions.</p> <p>Remove and clean restrictors in bypass block (See hydraulic diagram). Change hydraulic oil + filter.</p> <p>Check polarity. Red positive (+), black negative (-).</p> |
| ParaLift lock does not lock. Boom lift raises to max. position, when tractor hydraulics are engaged. | Back pressure in return line exceeds 220 psi (15 bar). | <p>Connect the return line with a free flow to hydraulic oil reservoir.</p> <p>Divide return line in two and lead return oil back to reservoir via two spool valves.</p> |
| Oil heats up in Closed Center systems. | <p>Bypass valve does not close properly.</p> <p>Internal leaks in flow regulator.</p> | <p>Check / close (screw in) by-pass valve.</p> <p>Replace flow regulator O-rings and backup rings.</p> <p>Replace flow regulator.</p> |
| Individual hydraulic piston does not move. | Clogged restrictor. | Dismantle and clean restrictor. |

TWIN System - Blower

| FAULT | PROBABLE CAUSE | CONTROL / REMEDY |
|--|--|--|
| Max. revolutions cannot be obtained. | <p>Tractor's PTO speed is lower than 1000 rpm (reading failure on tractor meter).</p> <p>Feed pressure too low.</p> <p>Pump/motor is worn.</p> | <p>Check tractor's PTO speed (rpm).</p> <p>Check tractor meter.</p> <p>Adjust feed pressure to correct setting.</p> <p>Get transmission checked by your HARDI® dealer.</p> |
| Noisy blower transmission. | <p>Wrong oil quality (foam).</p> <p>Feed pressure too low.</p> <p>Oil filter is clogged (pressure gauge indicator is in the red area).</p> | <p>Change oil to correct quality.</p> <p>Adjust feed pressure.</p> <p>Change oil filter.</p> |
| Formation of foam in oil tank. | <p>Pump/motor is worn.</p> <p>Wrong oil quality (foam).</p> <p>Mixture of hydraulic oil and other oil quality (e.g. universal oil).</p> <p>Oil change interval not kept.</p> <p>Leak on the pump suction line.</p> | <p>Get transmission checked by your HARDI® dealer.</p> <p>Change oil to correct quality.</p> <p>Change oil to correct quality.</p> <p>Change oil to fresh, clean oil of correct quality.</p> <p>Check hydraulic pump suction line for leaks.</p> |
| Blower speed will not stay at adjusted level. | <p>No signal from speed sensor at the blower.</p> <p>Bad / corroded electrical connections.</p> | Check the wire connection between sensor and actuator for damages. |
| Blower speed control does not start up. | Blown fuse(s). | Check power supply and fuse. |
| Oil leak from pump / motor shaft seal (the seal is pressed out). | <p>Drain hoses from motor / pump housing is blocked.</p> <p>Too much pressure in pump/motor housing (pump / motor worn).</p> | <p>Check the drain hose(s) for bends, damages and proper attachment.</p> <p>Get transmission checked by your HARDI® dealer.</p> |

Indication of Sensors for Boom Folding

In case of failure to fold the boom, with a fully functional hydraulic system, sensors located on the boom may cause an interruption of the boom folding.

 **ATTENTION!** The folding sensors are mounted only on booms with a width of 120' (36 meters).

If the boom is in negative tilt position, this can lead to damages on the boom when folding! These sensors are therefore installed to protect the boom.

If a sensor is defective or missing, folding of the boom is automatically interrupted, until the sensor is replaced.

A junction box (see picture) at the rear of the sprayer has electric connections to the folding sensors, and a button with an LED light is mounted on the front side of the junction box.

The LED light blinks correspondingly to how the system detects the sensors - see the table below.



| Boom width | Blinking mode for LED light | State of sensors |
|------------------------|---|--|
| Up to 100' (30 meters) | Blinks for 1 second, pauses for 1 second, and repeats. | No sensors are installed or detected. Normal operation for boom folding. |
| 120' (36 meters) | Blinks four times a second, pauses for 1 second, and repeats. | Four sensors detected. Normal operation for boom folding. |
| 120' (36 meters) | Blinks shortly once a second, pauses for 1-2 seconds, and repeats. | Left folding sensor defective or missing. |
| 120' (36 meters) | Blinks shortly twice a second, pauses for 1-2 seconds, and repeats. | Left tilt sensor defective or missing. |
| 120' (36 meters) | Blinks shortly three times a second, pauses for 1-2 seconds, and repeats. | Right tilt sensor defective or missing. |
| 120' (36 meters) | Blinks shortly four times a second, pauses for 1-2 seconds, and repeats. | Right folding sensor defective or missing. |
| 120' (36 meters) | Blinks continuously 5 times a second. | Emergency mode. Protection disabled. |

How to Make an Emergency Folding of the Boom

If you need to transport the sprayer for changing a defective folding sensor, first ensure that nothing else prevents the boom from being folded correctly and that no persons are in the folding area!

Now press the button with the LED light once on the junction box - this will override the sensor alarms.

Continue folding the boom into transport position by using the controls in the tractor.

This emergency mode for the sensors is reset only after the tractor has been turned off and restarted.

7 - Fault Finding

Electric Fuses

In case of failure to operate the sprayer correctly due to malfunctions, check if the fuse is intact for the function in question. If yes, the malfunction is not here.

If no, change the blown fuse and check the function on the sprayer again.



WARNING! The operator of the sprayer may open an electric junction box, check the fuse, change it if needed and reassemble the junction box. Any other changes or modifications of the circuit boards must be carried out only by qualified HARDI® personnel. Ask your dealer if in doubt.

Only replace a fuse with the same type and size. Using a bigger fuse will result in damages to the electric components. Risk of fire.

Example of a printed circuit board in a junction box on the sprayer:

- A. Blade fuse, 15 amps (15 A).
- B. HARDI® item number for the printed circuit board.

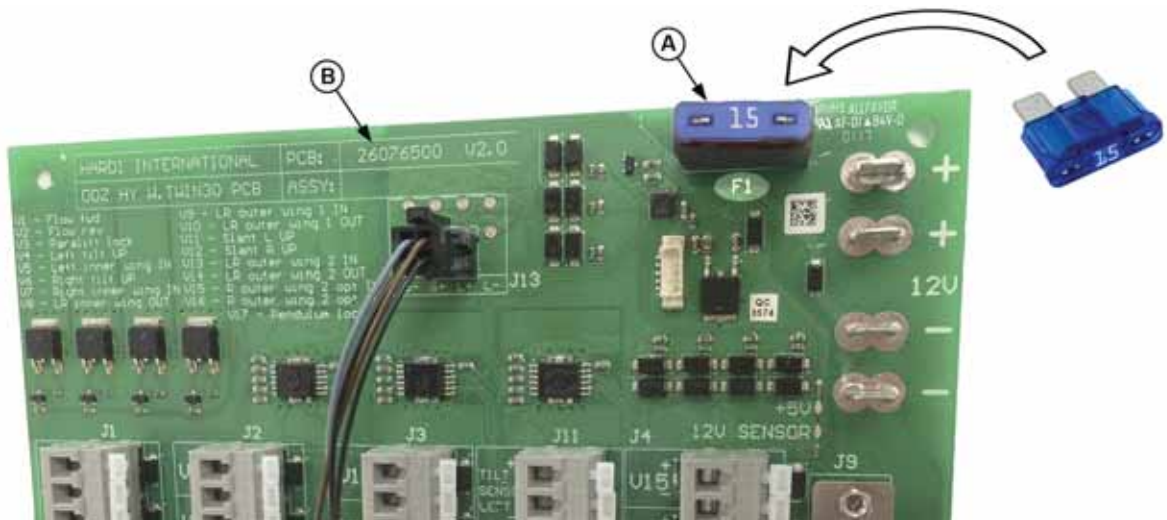

Overview of Fuses

Most fuses have a short text print nearby; above it is F1. This text tells which function on the sprayer is connected here - see the overview below. The fuses are blade fuses unless otherwise mentioned.

To verify the correct printed circuit board when inspecting a fuse, check the HARDI® item number (26xxxxxx).

| Location of printed circuit board | HARDI® item number | Fuse text | Fuse rating | Function on the sprayer |
|--|--------------------|-----------|-------------|---|
| Junction box for JobCom and ISOBUS | 26052700 | F1 | 10 A | Right boom wing, angle of TWIN air + speed of TWIN blower |
| | | F2 | 10 A | Left boom wing, angle of TWIN air |
| | | F3 | 10 A | Power for NORAC sensors |
| | | F4 | 15 A | Power from tractor to: - Electric system - NORAC hydraulics - FluidBox |
| | 26029200 | F1 | 25 A | DAH interface |
| Junction box for boom hydraulics - TWIN FORCE boom | 26076500 | F1 | 15 A | Active yaw damping (valves Y1 - Y4) Right inner wing (valve V7) |
| | | | | |
| Junction box for boom lights | 26057300 | F1 | 5 A | Right boom wing |
| | | F2 | 5 A | Left boom wing |
| | | F3 | 3 A | Working zone |
| Junction box for fluid functions - HC 5500 (no JobCom) - DAH | 26052900 | F1 | 10 A | Option for TWIN sprayers (not used) |
| | | F2 | 10 A | Option for TWIN sprayers (not used) |

| Location for other fuse types | HARDI® item number | Fuse text | Fuse rating | Function on the sprayer |
|-----------------------------------|--------------------|-----------|-------------|---|
| ISOBUS retrofit kit for tractor | 26040600 | J03, J04 | 100 A | Cable between tractor battery and ISOBUS connection, red wire. MIDI Bolt-down fuse. |
| ISOBUS breakaway connector (IBBC) | 26040300 | - | 30 A | Pin 2 and 4: Protection for power to the sprayer's electronic control unit (ECU). JCASE cartridge fuse. |
| | | - | 60 A | Pin 1 and 3: Protection if cable connections to plus and minus from the tractor battery have been swapped around by mistake. JCASE cartridge fuse. |

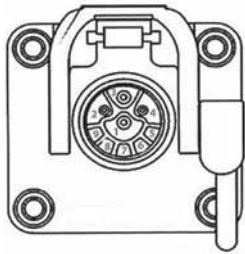

7 - Fault Finding

Mechanical Problems

Emergency Operation - Hydraulics

In case of power failure, the damper control can be operated as follows:

1. Remove plastic cover (A) from valve (B).
2. Turn valve (B) inwards.

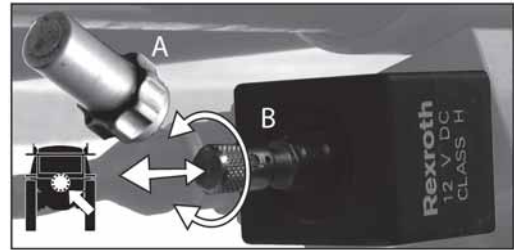

Emergency Operation - EasyClean Filter

If difficulties with opening the filter and closing the built-in valve occur, it can be emergency handled by using a 13 mm wrench on the key profile (A).

Also the filter can be drained before filter element at the drain plug (B).



WARNING! Always wear protective clothing and gloves before opening the filter!

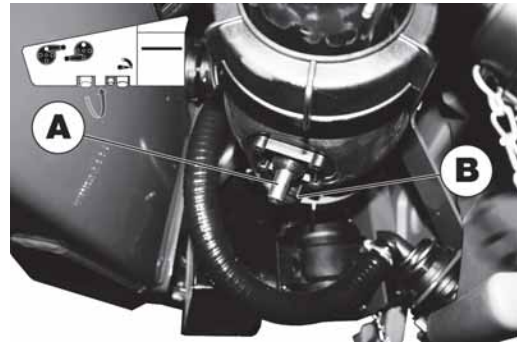

Emergency Operation - Liquid System

In case of power failure, it is possible to operate all functions of the operating unit manually.

Controller HC 6500 (and higher) and ISOBUS

Disconnect the power supply to the sprayer (depends on the tractor/sprayer setup).

Manually turn the control knobs on the distribution valves.

- If they are easily turned by hand, the power is shut off correctly.
- If they are hard to turn, you need to disconnect e.g. ISOBUS cable to turn off the power for these valves.



8 - Technical Specifications

Dimensions

General Info

All dimensions, values and weights are depending on mounted options and specific adjustments.

Overall Dimensions

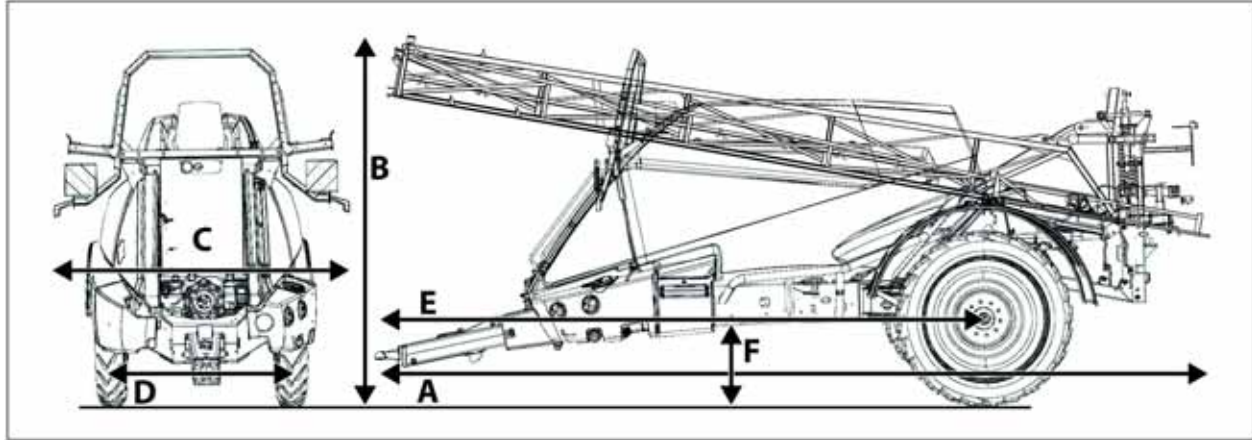

| | A | B | C | D | E | F |
|------|-------|--------|-------|------------|--------|-----|
| 4500 | 25'7" | 11'10" | 11'6" | 60" to 90" | 17'5" | 31" |
| 5500 | 28'3" | 11'10" | 11'6" | 60" to 90" | 17'5" | 31" |
| 7000 | 28'3" | 12'0" | 11'6" | 60" to 90" | 19'10" | 31" |

All measurements are in feet and inches

Wheel and Axle Dimensions

| Wheel | Adj. axle | Fixed axle | Duals 22" row | Duals 30" row | Clearance* |
|-------------|-----------|------------|---------------|---------------|------------|
| 320/90 R50 | 60" - 90" | 120" | 88"/132" | 60"/90" | 30.3" |
| 480/80 R46 | 60" - 90" | 120" | 88"/132" | 60"/90" | 32.2" |
| 380/105 R50 | 60" - 90" | 120" | 88"/132" | 60"/90" | 33.5" |
| 480/80 R50 | 60" - 90" | 120" | 88"/132" | 60"/90" | 34.5" |

*under axle

Tire Pressure

The following charts list the recommended tire pressure by model and tire size. Tire pressure may need to be adjusted depending on the actual machine weight, tire brand, or conditions.

| Single tires | Tire size | | | | | | |
|--------------|---------------|-------------------------|-------------------------|------------------|------------------|------------------|------------------|
| | Sprayer model | 320/90 R50 ¹ | 320/90 R50 ² | 380/90 R46 | 480/80 R46 | 380/105 R50 | 480/80 R50 |
| 4500 | | 52 psi (3.6 bar) | 60 psi (4.1 bar) | 60 psi (4.1 bar) | 40 psi (2.8 bar) | 40 psi (2.8 bar) | 40 psi (2.8 bar) |
| 5500 | | 52 psi (3.6 bar) | 70 psi (4.8 bar) | 70 psi (4.8 bar) | 52 psi (3.6 bar) | 50 psi (3.4 bar) | 50 psi (3.4 bar) |
| 7000 | | N/A as singles | N/A as singles | N/A | N/A | 60 psi (4.1 bar) | 60 psi (4.1 bar) |

1 - Load Index: 161

2 - Load Index: 169

| Duals | Tire size |
|---------------|------------------|
| Sprayer model | 320/90 R50 |
| 4500 | 30 psi (2.1 bar) |
| 5500 | 35 psi (2.4 bar) |
| 7000 | 40 psi (2.8 bar) |



DANGER! Never inflate tires more than to the pressure specified on the tire. Over-inflated tires can explode and cause severe personal injuries! See "50 Hours Service - Tire Pressure" on page 106.

8 - Technical Specifications

Weight

4500 with Twin Force boom

| Boom Width | Empty tank | | | | | Full tank* | | | | |
|----------------|---------------------|------------|-----------|------------|--------------|---------------------|------------|-----------|------------|--------------|
| | Folded in transport | | Unfolded | | Total Weight | Folded in transport | | Unfolded | | Total Weight |
| | Axle load | Hitch load | Axle load | Hitch load | | Axle load | Hitch load | Axle load | Hitch load | |
| 80 ft. | 10987 | 1949 | 12058 | 878 | 12936 | 18951 | 4989 | 20022 | 3918 | 23940 |
| 90 ft. | 11132 | 1991 | 12285 | 838 | 13123 | 19096 | 5031 | 20249 | 3878 | 24127 |
| 100 ft. | 11231 | 2013 | 12432 | 812 | 13244 | 19195 | 5053 | 20396 | 3852 | 24248 |
| 120 ft. | 11499 | 2340 | 13154 | 684 | 13839 | 19463 | 5380 | 21118 | 3724 | 24843 |

All weights in pounds (lbs)

*Main tank capacity: 1200 gal (4542 L), Rinsing tank capacity: 122 gal (460 L), filled with water

5500 with Twin Force boom

| Boom Width | Empty tank | | | | | Full tank* | | | | |
|----------------|---------------------|------------|-----------|------------|--------------|---------------------|------------|-----------|------------|--------------|
| | Folded in transport | | Unfolded | | Total Weight | Folded in transport | | Unfolded | | Total Weight |
| | Axle load | Hitch load | Axle load | Hitch load | | Axle load | Hitch load | Axle load | Hitch load | |
| 80 ft. | 12248 | 2162 | 13224 | 1186 | 14410 | 22302 | 6443 | 23278 | 5467 | 28745 |
| 90 ft. | 12393 | 2204 | 13451 | 1146 | 14597 | 22447 | 6485 | 23505 | 5427 | 28932 |
| 100 ft. | 12492 | 2226 | 13598 | 1120 | 14718 | 22546 | 6507 | 23652 | 5401 | 29053 |
| 120 ft. | 12760 | 2553 | 14320 | 992 | 15313 | 22814 | 6834 | 24374 | 5273 | 29647 |

All weights in pounds (lbs)

*Main tank capacity: 1600 gal (6056 L), Rinsing tank capacity: 122 gal (460 L), filled with water

7000 with Twin Force boom

| Boom Width | Empty tank | | | | | Full tank* | | | | |
|----------------|---------------------|------------|-----------|------------|--------------|---------------------|------------|-----------|------------|--------------|
| | Folded in transport | | Unfolded | | Total Weight | Folded in transport | | Unfolded | | Total Weight |
| | Axle load | Hitch load | Axle load | Hitch load | | Axle load | Hitch load | Axle load | Hitch load | |
| 80 ft. | 12358 | 2272 | 13334 | 1296 | 14630 | 25052 | 7244 | 26028 | 6268 | 32296 |
| 90 ft. | 12503 | 2314 | 13561 | 1256 | 14817 | 25197 | 7286 | 26255 | 6228 | 32483 |
| 100 ft. | 12602 | 2336 | 13708 | 1230 | 14938 | 25296 | 7308 | 26402 | 6202 | 32604 |
| 120 ft. | 12870 | 2663 | 14430 | 1102 | 15533 | 25564 | 7635 | 27124 | 6074 | 33199 |

All weights in pounds (lbs)

*Main tank capacity: 2000 gal (7570 L), Rinsing tank capacity: 122 gal (460 L), filled with water

Specifications

Diaphragm pumps

| Pump model 464/6.5 | PSI | RPM | GPM | HP |
|--------------------|-----|------|------|------|
| | 0 | 1000 | 92.2 | 4.3 |
| | 220 | 1000 | 78.7 | 13.8 |

| Pump model 464/10.0 | PSI | RPM | GPM | HP |
|---------------------|-----|-----|------|------|
| | 0 | 540 | 74.0 | 2.4 |
| | 220 | 540 | 68.4 | 11.1 |

Tractor Requirements

Power Take-off

Min. / Max. operating torque (kW): See type sign for liquid pump.

The type sign is located on the front side of the pump facing towards the tractor.



Hydraulic System

| | |
|---|---------------------------------|
| Max. operating temperature | 176° F (80° C) |
| Max. operating pressure from the tractor | 3050 psi (210 bar) |
| Min. operating pressure from the tractor | 2610 psi (180 bar) |
| Max. flow from tractor | 32 gal/min (120 l/min) |
| Min. flow from tractor @ 2900 psi (200 bar) | 4 - 21 gal/min (15 - 80 l/min)* |
| Max. oil filter rating | 10 µm |

* Depending on scope of supply.



DANGER! If one or more the values are exceeded, this may cause damages and sudden leaks on the sprayer. Risk of injuries and fatal accidents.

Hydraulic Oil

Oil from the tractor to the sprayer must have been filtered according to ISO 4406 20/14 as a minimum. Particles bigger than 25 micron in size must be filtered from the oil (Filtration quotient β₂₅₋₇₅, ISO 4572-81 Multipass test).

- Follow the tractor oil change schedule as directed.
- Choose hydraulic oil with anti-foam and anti-oxidant additives.

Be especially cautious where the tractor transmission oil is also used for the sprayer hydraulics. Consult the tractor dealer if in doubt.

| | |
|----------------|---|
| Type | Hydraulic oil with anti-foam and antioxidant additives. |
| Purity | ISO 4406 20/14. Filtration quotient β ₂₅₋₇₅ , ISO 4572-81. |
| Multipass test | 25 micron absolute. |
| Viscosity | Minimum: 10 mm ² /s (cSt). Maximum: 100 mm ² /s (cSt). At normal operation: 15 - 35 mm ² /s (cSt). |

8 - Technical Specifications

Voltage

The sprayer is designed for the following voltage only:

| | |
|----------------------------|-------------------------------------|
| Voltage | 12 V DC. Tolerance: -1.5/+3.0 V DC. |
| Tolerance for voltage | - 1.5 V / + 3.0 V |
| Current from tractor | 40 A peak |
| Blade fuses on the sprayer | 25 A * |



* The blade fuses usually allow up to 50 A for a few seconds before blowing.

⚠ DANGER! If the tolerances for voltage are exceeded, the electrical system can fail. Risk of fire. Risk of defect or malfunctioning components.

Power Consumption

Recommended tractor engine output are as follows.

| Main tank volume (liters) | Output (hp) | Output (kW) |
|---------------------------|-------------|-------------|
| 4500 | 175 | 130 |
| 5500 | 190 | 140 |
| 7000 | 210 | 160 |

Temperature and Pressure Ranges

Spray Liquid System

| | |
|---|-------------------------|
| Operating temperature range | 36 - 104° F (2 - 40° C) |
| Operating pressure for the safety valve | 215 psi (15 bar) |
| Max. pressure on the pressure manifold | 290 psi (20 bar) |
| Max. pressure on the suction manifold | 22 psi (1.5 bar) |

Filters

The higher the number of mesh, the finer the filtration.

| Mesh | Size of openings in the filter | Color | Filter name / position | | | | |
|------|--------------------------------|--------|------------------------|---------|---------|---------------|--------|
| | | | EasyClean | Cyclone | In-Line | Tank strainer | Nozzle |
| 18 | 1.00 mm | White | - | - | - | Yes | - |
| 30 | 0.58 mm | Green | Yes | - | - | - | - |
| 50 | 0.30 mm | Blue | Yes | - | Yes* | - | Yes* |
| 80 | 0.18 mm | Red | Yes | Yes | Yes* | - | Yes* |
| 100 | 0.15 mm | Yellow | - | - | Yes* | - | Yes* |

*depending on selected nozzles

Technical Residue

Residue in the dilutable volume is mentioned in the table below.

The non-dilutable volume varies depending on the boom width and installed options in the fluid system. Worst case technical residue for the sprayer with the largest tank, largest fluid system and widest spray boom is stated below. Smaller booms and fluid systems with less options will have less residue.

| | |
|------------------------|------------------------|
| Main tank: 7000 liters | 18 gallons (69 liters) |
| FlexCapacity pump | |

Blower For TWIN Air System

Blower Speed

Maximum revolutions for blower impeller: 3100 rpm.

Air Speed

Next to the spray nozzles: 0 - 78 mph (0 - 35 m/s).

This equals 0 - 16,000 ft³ of air per foot of spray boom per hour.



Airborne Noise Emission

TurboFor sprayers with TWIN air system, the airborne noise emissions, or sound pressure levels, have been measured in these defined operator positions and with the mentioned noise emitting components running:

| | |
|--|---|
| <p>1. When standing next to the TurboFiller, with the PTO speed set at 1000 rpm, with the TWIN gearbox running: <u>Noise = 70 dB(A).</u></p> | |
| <p>2. When standing next to the TurboFiller, with the PTO speed set at 1000 rpm, with the TWIN gearbox running, with the TWIN blower running at full speed: <u>Noise = 77 dB(A).</u></p> |  |
| <p>3. When sitting in the tractor cab, with the PTO speed set at 1000 rpm, with the TWIN gearbox running, with the TWIN blower running at full speed: <u>Noise = 67 dB(A).</u></p> | |



NOTE! The noise emission was measured for a standard type of TWIN sprayer. The noise level for other TWIN sprayers may differ insignificantly from the specified value. The TWIN system emits a relatively uniform noise when running.

The noise emission test was carried out using a New Holland TM125 tractor. If you are using another tractor, the noise level in the tractor cab may differ a little from the specified value. The tractor noise is of course a part of the total noise level.

8 - Technical Specifications

Materials and Recycling

Disposal of the Sprayer

When the equipment has completed its working life, it must be thoroughly cleaned.

The tanks, hoses and synthetic fittings can be incinerated at an authorized disposal plant.

The metallic parts can be scrapped. Steel parts are made of various types of treated steel.

Always follow local legislation regarding disposal.

Materials Used

| | |
|-------------------------|-------------------------------|
| Tanks: | Plastic (HDPE) |
| Chassis: | Steel |
| Boom: | Steel, aluminum |
| Tires: | Rubber |
| Mudguards: | Plastic (PE) |
| Grey side shields: | Plastic (PE) |
| Air blower housing: | Steel |
| Air impeller blades: | Glass reinforced plastic (PA) |
| Air guide on boom: | Aluminum |
| Bag for air guide: | Plastic (PVC) |
| Pump housing: | Grey cast iron (GG200) |
| Pump diaphragms: | Plastic (PUR) |
| Hoses (suction lines): | Plastic (PVC) |
| Hoses (pressure lines): | Rubber (EPDM) |
| Valves: | Glass reinforced plastic (PA) |
| Hose and pipe fittings: | Glass reinforced plastic (PA) |
| Filter housings: | Plastic (PP) |
| Nozzles: | Plastic (POM) |



Disposal of Cleaning Water

Protect the environment.

When cleaning the sprayer inside and outside, dispose of chemical residues in the liquid system and water containing cleaning agent according to local regulations.



Electrical Connections

Rear Lights

The wiring is in accordance with ANSI/ASAE S279.11.

| Position | Wire color |
|---------------------------------|------------|
| 1. Ground | White |
| 2. Work lamps | Black |
| 3. LH flashing & turn indicator | Yellow |
| 4. Free | Red |
| 5. RH flashing & turn indicator | Green |
| 6. Free | Brown |
| 7. Free | Blue |

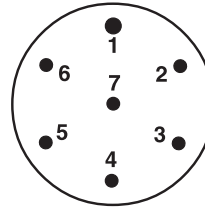

8 - Technical Specifications

Boom and Work Lights

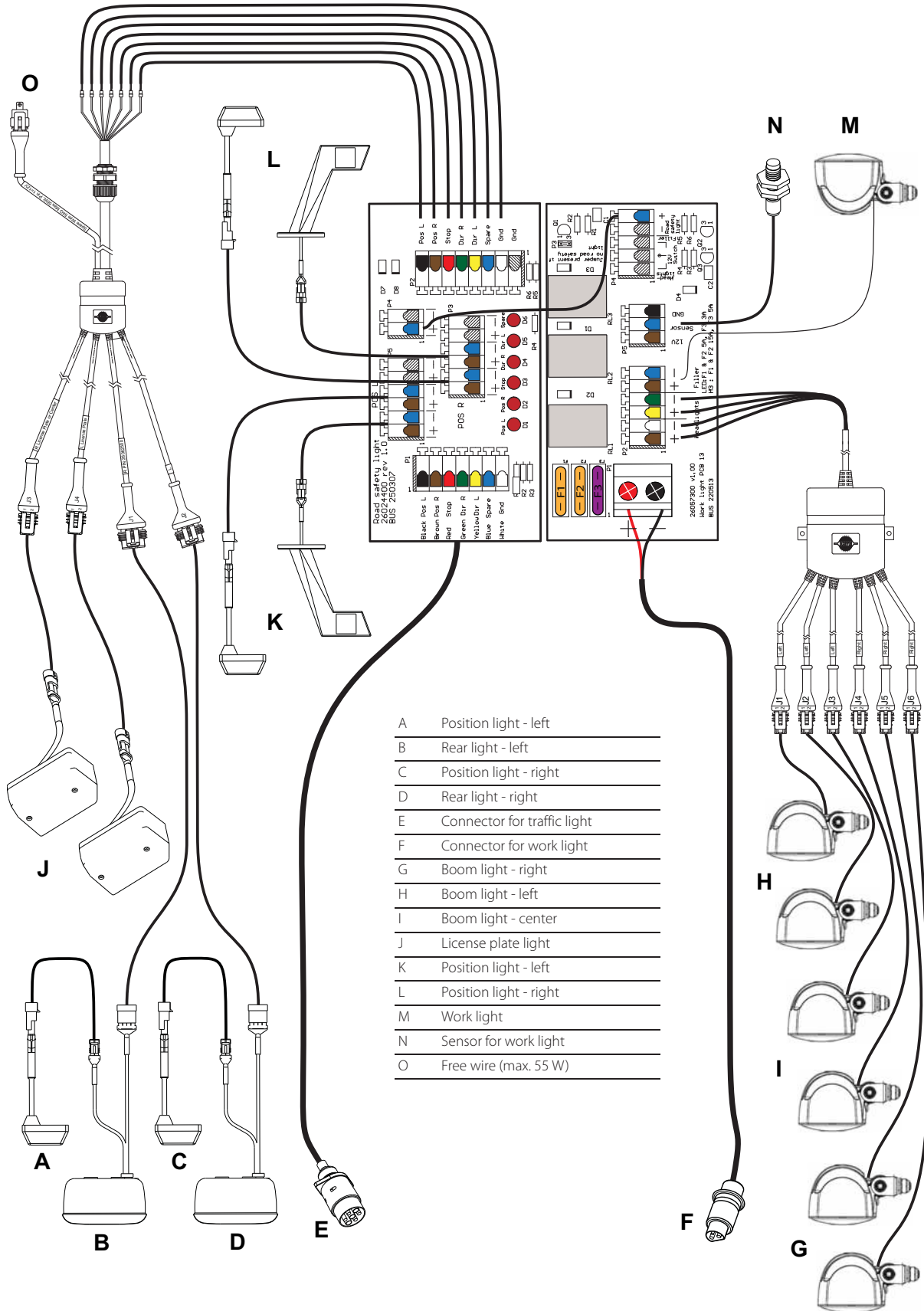

Hydraulic Diagrams

Chassis

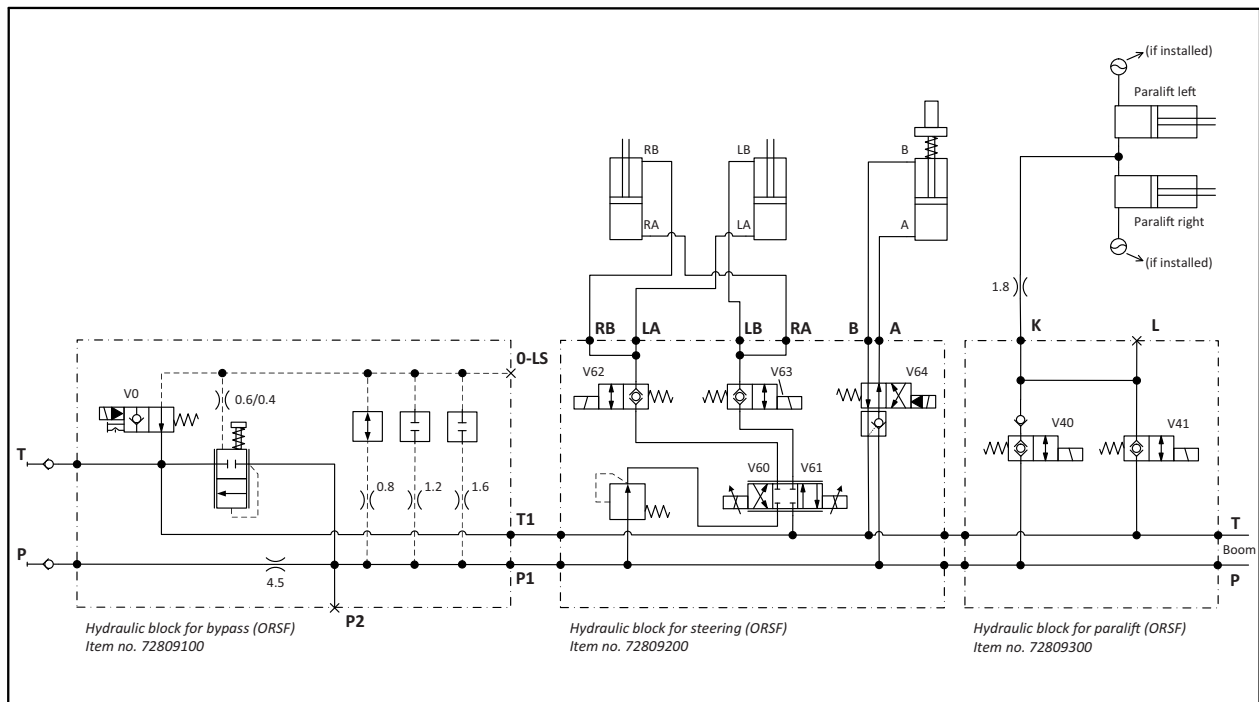

8 - Technical Specifications

TWIN System - Transmission

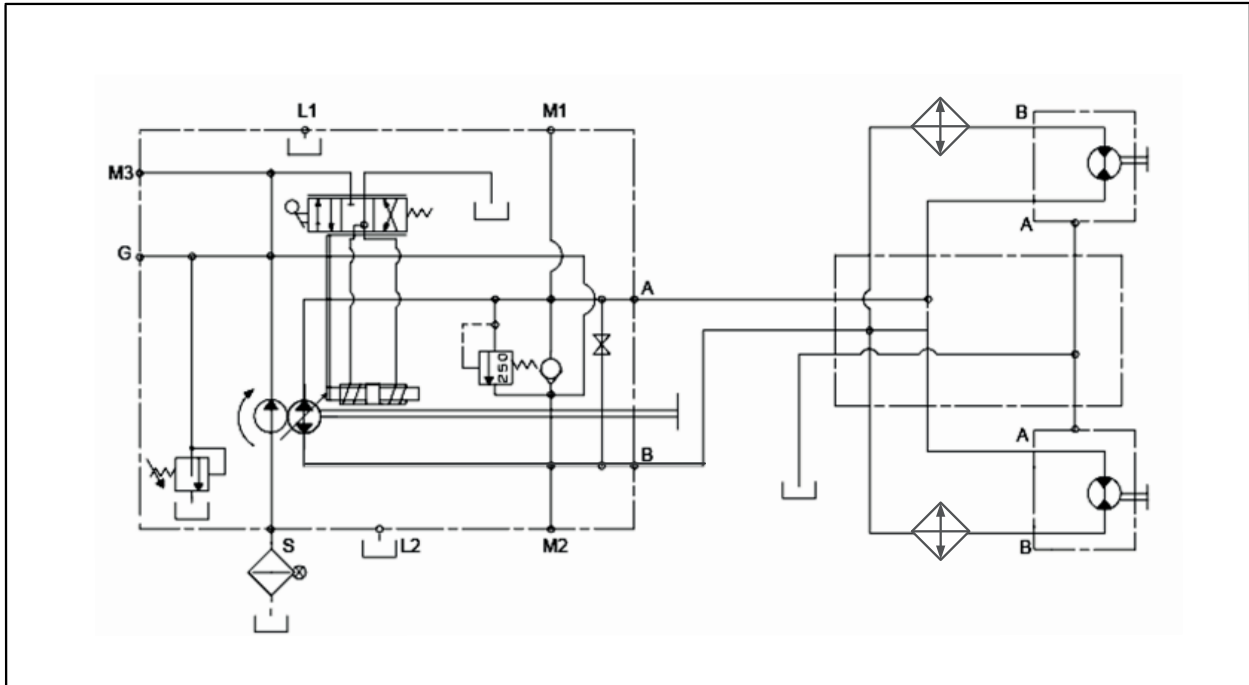

Spray Boom, 80' - 100' (24 - 30 m)

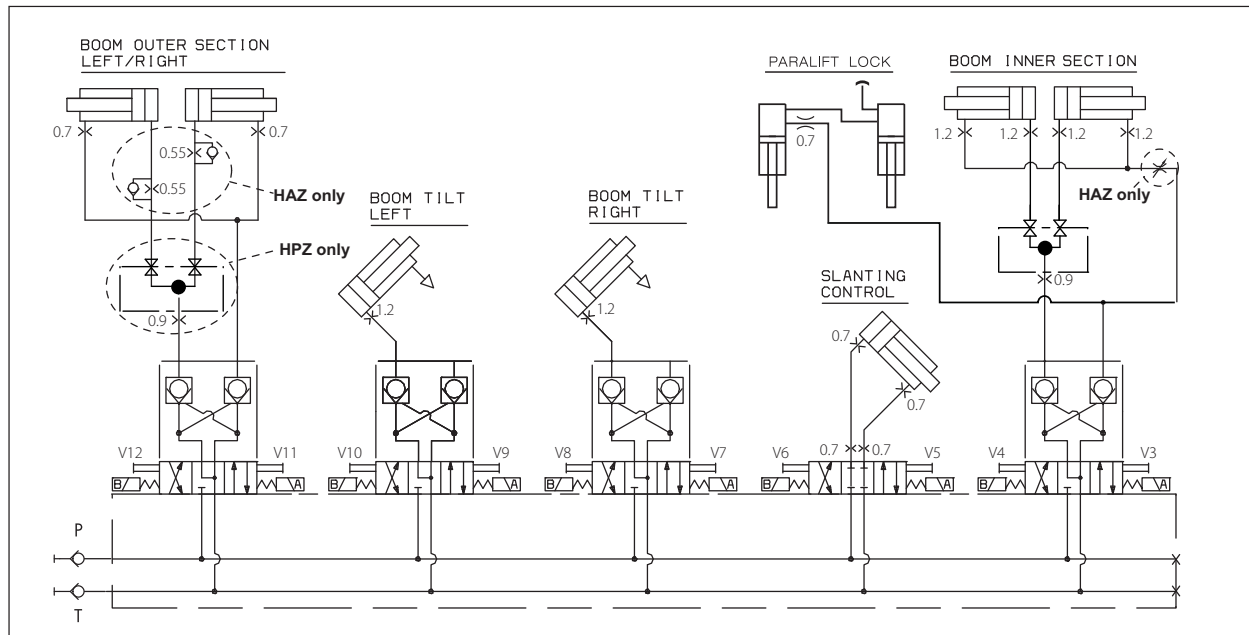

Spray Boom, 120' (36 m)

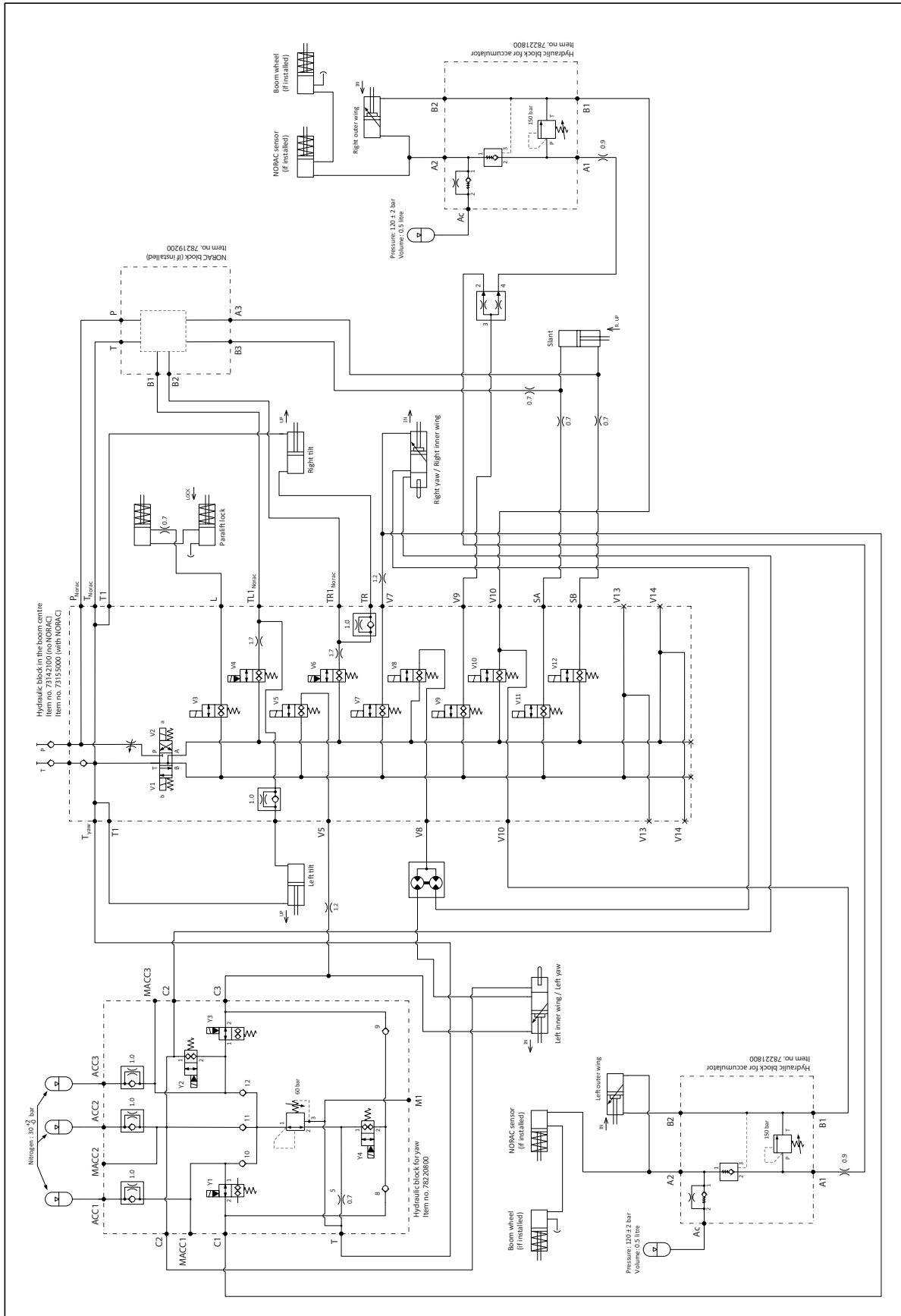

8 - Technical Specifications

Warranty policy and conditions

HARDI® NORTH AMERICA INC. , 1500 West 76th Street, Davenport, Iowa, USA hereinafter called "HARDI®", offers the following limited warranty in accordance with the provisions below to each original retail purchaser of its own manufacturer, from an authorized HARDI® dealer that such equipment is at the time of delivery to such purchaser, free from defects in material and workmanship and that such equipment will be warranted for a period of one year from the time of delivery to the end user, providing the machine is used and serviced in accordance with the recommendations in the Operator's Manual and is operated under normal farm conditions.

1. This limited warranty is subject to the following exceptions:
 - a)Parts of the machine not manufactured by HARDI®, (i.e. engines, tires, tubes, electronic controls and other components or trade accessories, etc.) are not covered by this warranty but are subject to the warranty of the original manufacturer. Any claim falling into this category will be taken up with the manufacturer concerned.
 - b)This warranty will be withdrawn if any equipment has been used for purposes other than for which it was intended or if it has been misused, neglected, or damaged by accident, let out on hire or furnished by a rental agency. Nor can claims be accepted if parts other than those manufactured by HARDI® have been incorporated in any of our equipment. Further, HARDI® shall not be responsible for damage in transit or handling by any common carrier and under no circumstances within or without the warranty period will HARDI® be liable for damages of loss of use, or damages resulting from delay or any consequential damage.
2. We cannot be held responsible for loss of livestock, loss of crops, loss because of delays in harvesting or any other expense or loss incurred for labor, supplies, substitute machinery, rental for any other reason, or for injuries either to the owner or to a third party, nor can we be called upon to be responsible for labor charges, other than originally agreed, incurred in the removal or replacement of components.
3. The customer will be responsible for and bear the costs of:
 - a)Normal maintenance such as greasing, maintenance of oil levels, minor adjustments including the boom.
 - b)Transportation of any HARDI® product to and from where the warranty work is to be performed.
 - c)Dealer travel time to and from the machine or to deliver and return the machine from the service workshop for repair unless otherwise dictated by state law.
 - d)Dealer traveling costs.
4. Parts defined as normal wearing items, (i.e. Pump Diaphragms, Valves, O-rings, Tires and V-belts) are not in any way covered under this warranty.
5. This warranty will not apply to any product which is altered or modified without the express written permission of the HARDI® Service and Engineering Departments and/or repaired by anyone other than an Authorized HARDI® Dealer.
6. Warranty is dependent upon the strict observance by the purchaser of the following provisions:
 - a)That this warranty may not be assigned or transferred to anyone.
 - b)That the Warranty Registration Certificate has been correctly completed by dealer and purchaser with their names and addresses, dated, signed and returned to the appropriate address as given on the Warranty Registration Certificate within 30 days of delivery to the purchaser.
 - c)That all safety instructions in the operator's manual shall be followed and all safety guards regularly inspected and replaced where necessary.
7. No warranty is given on second-hand products and none is implied.
8. Subject to the following terms, conditions and contributions, HARDI® extends the warranty on polyethylene tanks (excluding fittings, lids and gaskets) to FIVE YEARS on field sprayers. To qualify for this extended warranty, the tank must be drained and flushed with fresh water after each day's use. HARDI®'s liability is limited to replacement of defective parts FOB our plant in Davenport, IA at no cost to the purchaser for the first twelve months after date of purchase; at 20% of the then current retail price during the second year; at 40% during the third year; at 60% during the fourth year; and at 80% during the fifth year. This extended warranty is subject, in each instance, to the tank being inspected and approved for replacement or repair by HARDI® personnel before HARDI® will accept any liability hereunder.
9. Subject to the following terms, conditions and contributions, HARDI® extends the warranty on HARDI® diaphragm pumps (excluding wearing parts such as diaphragms, valves and o-rings) to FIVE YEARS. To qualify for this extended

9 - Warranty

warranty, the pump must be drained and flushed with fresh water after each day's use. HARDI®'s liability is limited to replacement of defective parts, FOB our plant in Davenport, IA at no cost to the purchaser during the first twelve months after date of purchase; at 20% of the then current retail price during the second year; at 40% during the third year; at 60% during the fourth year; and at 80% during the fifth year. This five year extended warranty is subject, in each instance, to the pump being inspected and approved for replacement or repair by HARDI® personnel before HARDI® will accept any liability hereunder.

10. HARDI® reserves the right to incorporate any change in design in its products without obligation to make such changes on units previously manufactured.
11. The judgement of the HARDI® Service Department in all cases of claims under this warranty shall be final and conclusive and the purchaser agrees to accept its decisions on all questions as to defect and the repair or exchange of any part or parts.
12. No employee or representative is authorized to change this warranty in any way or grant any other warranty unless such change is made in writing and signed by the CEO in the Davenport office. Approval of warranty is the responsibility of the HARDI® Service Department.
13. Any warranty work performed which will exceed \$1000.00 MUST be approved IN ADVANCE by the Service Department. Warranty claims filed without prior approval will be returned.
14. ANY pump replacement MUST be approved by the HARDI® Service Department.
15. Claims under this policy MUST be filed with the HARDI® Service Department within thirty (30) days of when the work is performed or warranty shall be void unless prior arrangements are made.
16. Parts which are requested for return by the HARDI® Service Department must be returned prepaid within thirty (30) days for warranty settlement.
17. Warranty claims must be COMPLETELY filled out including part numbers and quantities or claims will be returned to the submitting dealer.

DISCLAIMER OF FURTHER WARRANTY

THERE ARE NO WARRANTIES, EXPRESSED OR IMPLIED, EXCEPT AS SET FORTH ABOVE. THERE ARE NO WARRANTIES WHICH EXTEND BEYOND THE DESCRIPTION OF THE PRODUCT CONTAINED HEREIN. IN NO EVENT SHALL THE COMPANY BE LIABLE FOR INDIRECT, SPECIAL OR CONSEQUENTIAL DAMAGES (SUCH AS LOSS OF ANTICIPATED PROFITS) IN CONNECTION WITH THE RETAIL PURCHASER'S USE OF THE PRODUCT.

Index
Numerics

- 10 Hours Service
 - CycloneFilter, 105
 - EasyClean Filter, 104
 - Hydraulic Oil Level, 105
 - In-Line Filter, 104
 - Nozzle Filters, 105
 - Spraying Circuit, 103
- 50 Hours Service
 - Gearbox for TWIN System, 107
 - Greasing the Pump, 106
 - PTO, 107
 - Tire Pressure, 106
 - Transmission Shaft, 107
 - Wheel Nuts, 106
- 100 Hours Service
 - Re-tightening the Boom, 109
 - Steering, 109
- 250 Hours Service
 - Hoses and Tubes, 110
 - Hydraulic Circuit, 110
 - Wheel Bearings, 110
- 500 Hours Service
 - Gearbox for TWIN System, 110
 - Hydraulic Oil for TWIN System, 110
- 1000 Hours Service
 - Wheel Bearings and Brakes, 113

A

- Agitation
 - Before Resuming a Spray Job, 84
 - Valve, 25
- Air assistance, 34
- Anti-Corrosion Oil, 48

B

- Before Operation, 48
- Boom
 - Folding Speed, 62
 - Hydraulic Diagram 120', 159
 - Hydraulic Diagram 80'-100', 158
 - Pipe clamp, 118
 - Pipe Snap-Lock, 118
 - Readjustment, 123
 - Re-tightening, 109
 - Terminology, 37

C

- Chemical Container Rinsing Lever, 30, 81
- ChemLocker, 41
- Clean Water Tank, 31
- Cleaning
 - Chemical Container, 84
 - External Cleaning Device, 44
 - Standard, 88
- Clogging Indicator, 28
- Control Unit
 - Brackets, 55
 - Location, 39

- Operation, 72
- CycloneFilter, 29, 57, 105

D

- Disposal, 154
- Drain Valve
 - Seal Replacement, 117
 - Using, 93
- Drawbars
 - Rigid drawbar, 42
 - Suspended drawbar, 42
- DynamicFluid4, 26

E

- EasyClean Filter, 28
- Electrical Connector
 - ISOBUS, 54
 - JobCom, 54
 - Power and data, 54
 - Spray Box, 54
 - Traffic Light, 54
 - Working Light, 54
- Emergency Operation
 - Hydraulics, 148
 - Liquid System, 148
- External Cleaning Device, 44

F

- Filling
 - Clean Water Tank, 78
 - Liquid Chemicals in TurboFiller, 82
 - Powder Chemicals in TurboFiller, 83
 - Rinsing tank, 77
 - Washing Location, 76
 - Water, 76
 - Water Through Tank Lid, 77
- Filters, 28

G

- Grease
 - Gun Calibration, 96
 - Nipple, 96
- Grip
 - Location, 39
 - Operating, 70

H

- Hose Package Support, 51
- Hose Reel, 44
- Hydraulic system, 52
- Hydraulics
 - Boom, 35, 62
 - Closed Center, 36
 - Emergency Operation, 148
 - Open Center, 36
 - ParaLift, 35
 - Venting of Cylinders, 136

I

- Identification Plates, 21
- In-Line Filter, 28, 104

Index

J

Jack up the Sprayer, 48

L

Labels

Explanation of Warning Labels, 15

Level Indicator

Adjustment, 116

Wire Replacement, 117

Lifetime, 23

Light Bulbs, 134

Liquid System, 142

Load Sensing, 53

Lubricants, 95

Lubrication

Boom, 98

ParaLift, 99

PTO, 100

N

Noise Emission, 153

Nozzle

Filters, 28, 105

Holder, 119

Leaks, 119

Pressure Gauge, 40

Nozzle Pipe

Assembly, 121

Connector, 120, 122

Gasket Types, 122

Lock ring, 122

O-ring, 119, 121

Remove Lock Ring, 122

O

Off-Season Storage, 138

Oiling plan, 97, 98

Operator

Obligations, 12

Operational problems, 141

Operator

Instructions, 11

Safety, 50

P

ParaLift, 35

Parking the Sprayer, 85

Personal Protection, 79

Personal Protective Equipment, 13

Pesticide Information, 40

Poison information center, 18

Power Supply, 54

Pressure Filter, 29

Protective Gear, 79

PTO

Installation, 50

Lubrication, 100

Replacement of Cross Journals, 134

Replacement of Shield, 134

Pulling the Sprayer, 47

Pump, 24

Pump Speed Transducer, 116

Q

Quick Fill, 77

Quick Reference

Cleaning, 87

Operation, 85

R

Rear Lights, 155

Replacement

Drain Valve Seal, 117

Level Indicator Wire, 117

Pump Diaphragms, 115

Pump Valves, 115

Wear Bushing on Boom Lift, 134

Wear Bushing on Steering, 134

Requirements

Filling/Washing Location, 76

Tractor, 151

Returning to Refill, 85

Rinsing Tank, 31

Road Safety Kit, 54

S

SafeTrack, 42, 73

SafeTrack potentiometer connection, 51

Safety

Info, 70

Operator, 50

Precautions, 79

Symbols, 14

Valve, 123

Safety and Protection Equipment, 17

Snap-Lock For Feed Pipes, 118

Soak Wash, 92

Speed Sensor, 56

Spray Wand, 44

Sprayer

Parking, 85

Use, 23

Spraying Circuit, 103

Suction Filter, 28

T

Tank, 23

Tank Level Indicator, 43

Technical Residue, 93

Tire

Change, 135

Pressure, 149

Torque

Bolts and Nuts, 102

Hydraulic Hoses, 103

Track width adjustment, 67

Tractor Requirements

Hydraulic Oil, 151

Hydraulic Outlets, 52

Hydraulic System, 151

Power Consumption, 152

PTO, 151

- Voltage, 152
- Transmission Shaft, 50
- Trapeze Damping, 60
- TurboFiller, 30, 80
 - Rinsing, 84
 - Suction Valve, 30, 81
 - TurboDeflector Valve, 30, 81
- TWIN System
 - Air assistance, 34
 - Gearbox, 108

U

- Unloading the Sprayer, 47

V

- Valve
 - Adjustment of 3-Way, 123
 - Agitation, 25
 - Closed Center Hydraulics, 53
 - Open Center Hydraulics, 53
 - Pressure SmartValve, 25
 - Return, 29
 - Suction SmartValve, 25
 - TurboDeflector, 30, 81
 - TurboFiller Suction, 30, 81

- Valves

- Symbols, 24, 69

- Valves and symbols, 24

W

- Wheel

- Bearings, 110

- Nuts, 106



HARDI® North America Inc.

1500 West 76th St - Davenport, IA 52806

Ph: (563) 386-1730

Customer Service Email: custserv@hardi-us.com

Email: info@hardi-us.com

Website: www.hardi-us.com