

CONTROLLER HC5500

Instruction book - sw 4.00

67021003 - Version 2.00

US - 03.2008

HARDI® reserves the right to make changes in design, material, or specification without notice thereof.
HARDI® and other product names are registered trademarks of HARDI® Inc. in the U.S. and in other countries.

Table of Contents

1 - Welcome	
Welcome letter	1
2 - Safety notes	
Operator safety	1
General info	1
Local Poison Information Center	2
3 - Description	
General info	1
General info	1
Glossary and pictorial symbols	2
HARDI® LookAhead	2
SafeTrack	3
System description	4
Overall description	4
Keys	5
General Key description	5
General keystrokes, Example: Tank contents	6
Keystroke menu tree	8
Overview of buttons and switches	9
HC 5500 Display	9
Spraybox II	9
Spraybox II (TWIN only)	9
4 - System setup	
Tractor installation	1
Installation of control unit brackets	1
Power supply	1
Printer	2
Speed transducer for sprayer	2
Speed transducer for tractor	2
Foot pedal remote ON/OFF (optional)	2
Initial system start-up	3
Screen contrast adjustment	3
Daily settings	4
System start-up	4
LookAhead nozzle choice	4
Control units	4
5 - Menu 1 Daily settings	
Menu 1.1 Volume rate	1
How to change the volume rate	1
Menu 1.2 Tank contents	2
To change the displayed Tank contents	2
Menu 1.3 Select register	3
Menu 1.3.1 Register readout and selection	3

Table of Contents

6 - Menu 2 Setup

Menu 2.1 Display readout	1
General info	1
Menu 2.1.5 Work rate	1
Menu 2.2 Auto functions	2
Menu 2.2.1 ON/OFF	2
Menu 2.2.2 Foam Marker (optional)	2
Menu 2.2.3 Dual line (not used in North America)	2
Menu 2.3 VRA/Remote control	2
Variable Rate Application (VRA) / Remote/ HARDI® AutoSectionControl	2
Menu 2.4 Set clock	3
How to set clock	3
Menu 2.5 Alarms	4
How to set up alarms	4
Menu 2.5.6 Audio level	4
Menu 2.6 Register names	5
How to name the registers	5
Menu 2.6.XX Copy name	5

7 - Menu 3 Calibration

Menu 3.1 Speed calibration	1
Menu 3.1.1 Sprayer	1
Menu 3.1.1.1 Constant	2
Menu 3.1.1.2 Practical	2
Menu 3.2 Flow calibration	3
Which method to use	3
Menu 3.2.1 Flow constant	3
Menu 3.2.2 Nozzle method	3
Menu 3.2.3 Tank method	4
Menu 3.2.4 Circulation	5
Menu 3.3 Boom	7
Menu 3.3.1 Width	7
Menu 3.3.2 Number of sections	7
Menu 3.3.3 Nozzles/section	7
Menu 3.3.4 End nozzles (optional)	7
Menu 3.4 Regulation constant	8
Regulation constant	8
Menu 3.5 Tank gauge	9
General info	9
Menu 3.5.1 Adjustment	9
Menu 3.5.2 Total	9
Menu 3.6 Track	11
General info	11
Track	11
Reversing the sprayer	12
Menu 3.6.1 Track width	12
Menu 3.6.2 Tractor drawbar	12
Menu 3.6.3 Dead zone	12
Menu 3.6.4 Damping	13
Menu 3.6.5 Alignment offset	13
Menu 3.6.6 Sensitivity	13
Emergency Track	14
Menu 3.7 LookAhead	15
Menu 3.7.X LookAhead calibration	15

Table of Contents

8 - Menu 4 Toolbox	
Menu 4.1 Measure	1
Trip meter	1
Menu 4.2 Service intervals	1
Menu and intervals.....	1
Service interval reset.....	1
Menu 4.3 Stop watch	2
Use as timer.....	2
Menu 4.4 Alarm clock	2
How to use alarm	2
Menu 4.5 Test	2
How to test	2
Menu 4.6 Speed simulation	2
How to use speed simulation.....	2
Menu 4.7 Emergency Track	3
Emergency Track.....	3
9 - Menu 5 Logbook	
Menu 5.1 Print	1
What you can print.....	1
Menu 5.2 Data dump	2
How to dump data	2
10 - Maintenance	
Off-season storage	1
Storage	1
11 - Fault finding	
Emergency operation	1
In an emergency situation.....	1
Operational problems	2
Operational faults	2
Mechanical faults	3
12 - Testing and fine tuning	
Testing and fine tuning	1
Fine tuning the flow constant - PPU	1
Pin & Wire connection	1
Testing flow transducer	1
Testing speed transducer	2
13 - Technical specifications	
Specifications	1
Specifications.....	1
Flow ranges for the flow transducers	1
Baud rate	1
Materials and recycling	2
Packaging information	2
Disposal of electronics.....	2
Charts	3
Chart for recording values.....	3
14 - Warranty	
Warranty Policy and Conditions	1

Table of Contents

Welcome letter



Dear Owner,

Thank you for purchasing a HARDI® product and welcome to the ever-increasing family of HARDI® sprayer owners.

Our sprayers and accessories are rapidly becoming a familiar sight on North American farms. We believe that this results from growers becoming increasingly conscious of crop protection input costs and the vital need for cost effective spray application equipment.

Please take the time to thoroughly read the Operator's Manual before using your equipment. You will find many helpful hints as well as important safety and operation information.

Some of the features on your HARDI® sprayer were suggested by growers. There is no substitute for "on farm" experience and we invite your comments and suggestions. If any portion of this instruction book remains unclear after reading it, contact your HARDI® dealer or service personnel for further explanation before using the equipment.

For Product, Service or Warranty Information:

- Please contact your local HARDI® dealer.

To contact HARDI® directly:

- Please use the HARDI® Customer Service number: 1-866-770-7063

- Or send your email to CUSTSERV@hardi-us.com

HARDI® NORTH AMERICA INC.

1500 West 76th St.
Davenport, Iowa 52806
Phone: (563) 386-1730
Fax: (563) 386-1710

8550 W. Roosevelt Avenue
Visalia, California 93291
Phone: (559)651-4016
Fax: (559) 651-4160

Visit us online at: www.hardi-us.com

337 Sovereign Rd.
London, Ontario N6M 1A6
Phone: (519) 659-2771
Fax: (519) 659-2821

Sincerely,

A handwritten signature in black ink, appearing to read "Tom L. Kinzenbaw".

Tom L. Kinzenbaw
President

Operator safety



This symbol means DANGER. Be very alert as your safety is involved!



This symbol means WARNING. Be alert as your safety can be involved!



This symbol means ATTENTION. This guides to better, easier and more safe operation of your sprayer!

General info

Note the following recommended precautions and safe operating practices.



Read and understand this instruction book before using the equipment. It is equally important that other operators of this equipment read and understand this book.



Keep children away from the equipment.



If any portion of this instruction book remains unclear after reading it, contact your HARDI® dealer for further explanation before using the equipment.



Turn electrical power off before connecting and disconnecting the display and transducers, servicing or using a battery charger.



If an arc welder is used on the equipment or anything connected to the equipment, disconnect power leads before welding.



Test with clean water prior to filling with chemicals.



Do not use a high pressure cleaner to clean the electronic components



Press the keys with the underside of your finger. Avoid using your fingernail.

2 - Safety notes

Local poison information center



If you live anywhere in the United States, the following toll free number will connect you to your Local Poison Information Center.

PHONE NO. 1 - 800 - 222 - 1222



If you live outside the United States, find the number for the poison control center in your phone book and write it in the space below:

PHONE NO. _____ - _____ - _____



Keep a list, in the space provided below, of all the chemicals that you have in use.

1. _____
2. _____
3. _____
4. _____
5. _____
6. _____
7. _____
8. _____
9. _____
10. _____

General info

General info

The HARDI® Controller 5500 is for use in agricultural and horticultural production. The Controller permits automatic control of application rate.

Main components are:

- * Controller
- * Spray Box
- * Junction box (on sprayer)
- * Jobcomputer (for SafeTrack and AutoSectionControl function)
- * Flow transducer (on sprayer)
- * Speed transducer (on sprayer or tractor)

The Controller has a four line display permitting much information to be shown at the same time. Display readout includes volume rate, speed, liquid rate per minute, total covered area, total volume sprayed and 99 trip registers. It includes a total register that summarizes data from the 98 trip registers. It is illuminated internally so readout is possible even for night-time work.

Functions include correct area with closure of up to 7 spray boom sections, alarm functions for volume rate, minimum tank contents, speed min./max. and possibility for audio/visual alarm.

The Spray Box has integrated controls for the spray functions, foam marker, end nozzles and optional electric valves.

The transducers utilized are chosen for long service life and good signal quality. The speed and flow transducer has a diode built into the housing to aid servicing. As the wheel or rotor turns, the diode will flash thereby indicating it is functioning correctly.

The Controller is also compatible for Variable Rate Application and is prepared for communication with Precision Farming tools.

Data dump of registers and configuration to a personal computer is possible.

The system has a non-volatile memory with no battery which simplifies storage. All parameters in the menus are saved in the Controller's memory and are not lost when the power is disconnected.

The Controller has been developed to last many years under agricultural conditions.

Optional transducers include pressure, revolutions, area meter and tank gauge. Other options include a 12 Volt printer and a foot operated remote ON/OFF for the Main ON/OFF.

3 - Description

Glossary and pictorial symbols

Controller	HARDI® Controller 5500 with display.
Spray Box	HARDI® Control Box with all basic control functions.
Junction box	Box on the sprayer for Controller and Control Box.
Jobcom	Box on the sprayer with SafeTrack computer and/or AutoSectionControl.
Transducer	Device that transforms variations to a signal. Also called a sensor.
[abc]	Text shown on the Controller display.
[X] or [Y]	Variable figures.
PPU	Pulses per unit. For speed and flow calibration, the unit measure is feet and gallon respectively.
EVC	Electric Valve Control unit. Designates an equal pressure liquid system.
EFC	Electric Fast Control unit. Designates a no equal pressure liquid system.
VRA	Variable Rate Application (often referred to "GPS").

Text shown in the shaded rectangular windows are what will be seen on the Controller display when pressing buttons as described in the explanations. An example of display read-out is shown to the right.

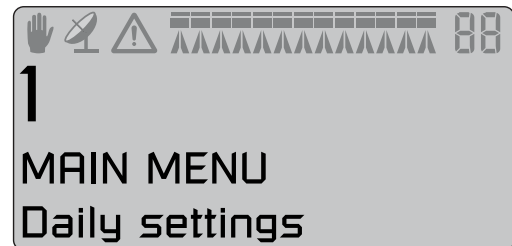

HARDI® LookAhead

With LookAhead, the pressure regulation valve can foresee the correct setting before the main switch goes to ON. It improves application precision, especially when re-starting after a tank fill.

The LookAhead feature is active when the boom is unfolded and the LookAhead menu is activated and calibrated to find it's position.

When the power is switched to ON, note the regulation valve will adjust from the actual setting to the minimum setting and then back again to determine it's actual position.

For LookAhead to function correctly the controller must know which nozzles and application rate will be used. This is selected from a number of nozzle choices stored in memory. At start up of the controller, it will prompt user for a choice between using nozzles used at last spray job or select a new nozzle to be used.



ATTENTION! The tractor gearbox must be an automatic or semi-automatic type with constant R.P.M. P.T.O., or the tractor must be driven with constant R.P.M. for the LookAhead to work properly.

SafeTrack

SafeTrack is a steering mechanism for the HARDI® COMMANDER sprayer. When using a track system, sprayer stability is a common concern. Many factors influence the sprayer, and conditions where the sprayer might tip over have to be dealt with. The factors that the driver can influence are:

- Driving behavior
- Field conditions
- Tire width
- Tire pressure

Read sprayer's instruction book for further information.

If unsafe driving occurs, an alarm will be triggered and the sprayer will align. Be aware that the alarm cannot be turned off as long as unsafe driving still occurs! (See paragraph "Menu 3.6 Track")



ATTENTION! If necessary, the level of security can be adjusted - please contact your local HARDI® dealer.



DANGER! The system has been calibrated during driving on flat fields. Special attention should be made when driving in hilly conditions.



DANGER! When driving on fields with deep tracks, the speed must be decreased.

3 - Description

System description

Overall description

1. Controller
2. Spray Box
3. To 12 Volt power supply
4. Multi wire plug and cable
5. Junction box (on sprayer)
- 5A. Jobcom (optional)
6. Flow transducer
7. Speed transducer
8. Printer (optional)
9. Harness for tractor speed/area switch/foot remote ON/OFF

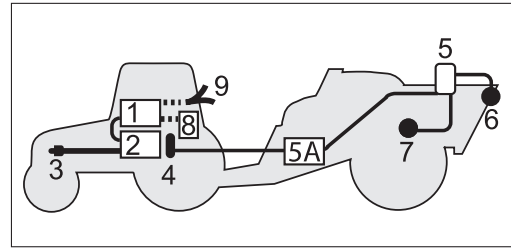

Keys

General key description

The HC 5500 controller buttons are placed in three groups; navigation keys, shortcut keys, distance and auto key.

The shortcut keys can be used for the following:



Short press: Displays volume sprayed for the active register.

Long press: Enter Register select (menu 1.3.1 Register select).



Short press: Displays the actual speed.

Long press: Enter Speed calibration (menu 3.1.1 Speed).



Short press: Displays the actual tank contents.

Long press: Enter Tank contents menu (menu 1.2 Tank contents).



Short press: Show Area covered for active register.

Long press: Enter Register select (menu 1.3.1 Register select).



Short press: Show the selected volume rate.

Long press: Enter Volume rate menu (menu 1.1 Volume rate).



Short press: Shows remaining spraying distance with actual tank contents.

Long press: Enter Measure distance menu (menu 4.1.1 Distance).

Pressing  will: Enable Auto function.

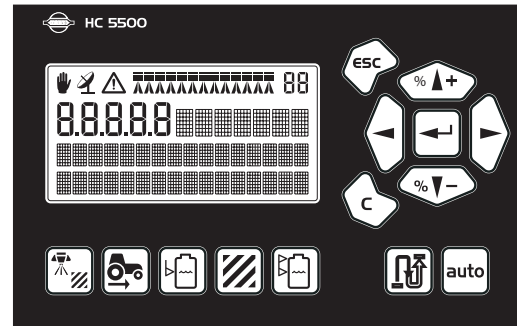

3 - Description

The navigation keys are used initially for set up in the menu system, and working screen.

To navigate the menus, press  to start the process. While in the menu system, buttons can be used for the following:

Pressing  will:

Scroll up,

Increase a value,

Pressing  will:

Scroll down,

Decrease a value,

Pressing  will:

Move the cursor to the left.

Pressing  will:

Move the cursor to the right.

Pressing  will:

Escape a menu (hold to escape all menus),

Escape without changing a value.

Pressing  will:

Clear a value,

Reset the active register (hold until countdown is finished).

Pressing  will:

Enter a menu,

Confirm (accept) a value.

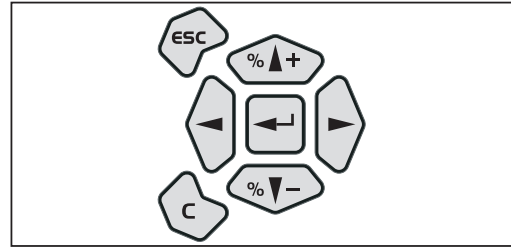

While at the working screen (not in menu system), the navigation keys can be used for the following:

Pressing  will:

Increase volume rate in steps or select another preset application rate.

Pressing  will:

Decrease volume rate in steps or select another preset application rate.

Pressing  will:

Reset the active register (hold until countdown is finished).

Pressing  will:

Enter a menu.

General keystrokes, Example: Tank contents

The following is a general description in keystrokes and display readout. The following example of changing the Tank contents value is used to illustrate this. Try it! The same method is used in all the menus.



ATTENTION! When a menu is open, the blinking number or value is the one that can be altered.



ATTENTION! The first line with icons will stay shaded except where first line is relevant.

3 - Description

Press  to enter the menu system [1 MAIN MENU].

The 2nd line will show the menu number.

The 3rd line will read the present menu.

The 4th line will show a choice.

Note the menu number [1] is blinking.

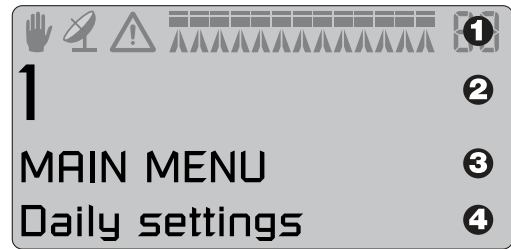

Press  to enter menu [1.1 Daily settings].

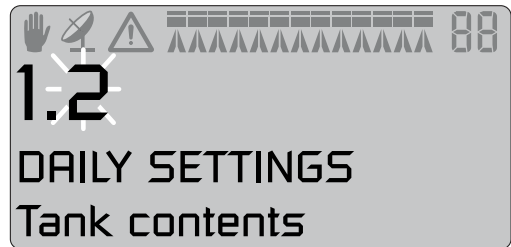

Press  or  to scroll to [1.2 Tank contents].

Note the last digit of the menu number [1.2] is blinking.



Press  to enter [1.2 TANK CONTENTS].

Note the value that can be changed is blinking.

Press  or  to move the cursor.

Press  or  to set the desired value.

Press  to confirm.

Press  and hold, to exit the menu system.

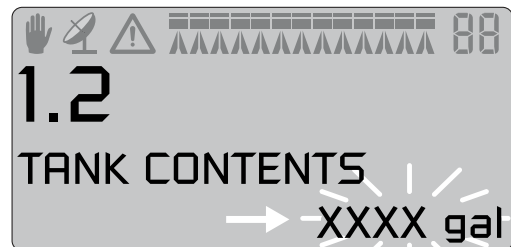

3 - Description

Keystroke menu tree

The first steps to choose a menu are shown below.

Press  to proceed into the menu. See the relevant section in the book.

Press  and hold to exit the menu system.

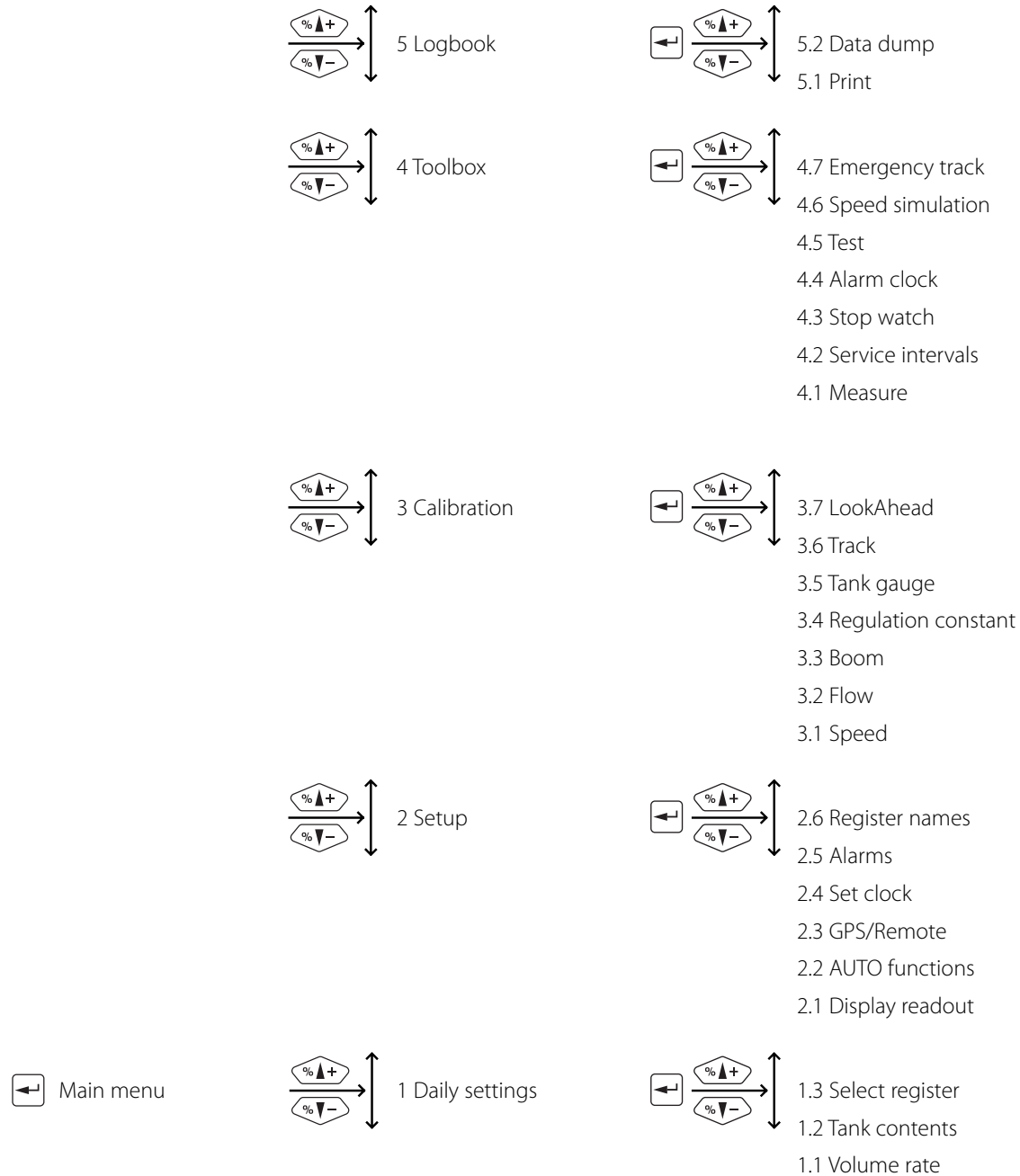

Overview of buttons and switches

HC 5500 Display

1. Display
2. Navigation keys*
3. Shortcut keys*

*pictorial symbols match icons used throughout manual.

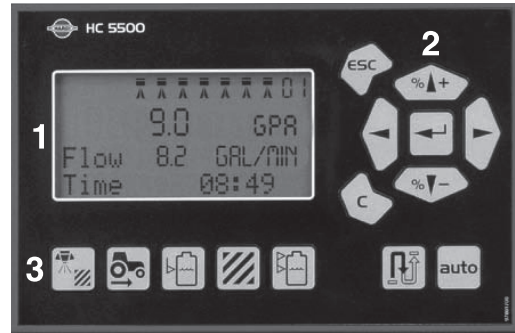

Spraybox II

1. Power switch
2. Manual pressure regulation
3. Main ON/OFF
4. End nozzle (Left/OFF/Right)*
5. Foam marker regulation*
6. Foam marker (Left/OFF/Right)*
7. Boom section valves
8. Valve function A-B*

*optional equipment

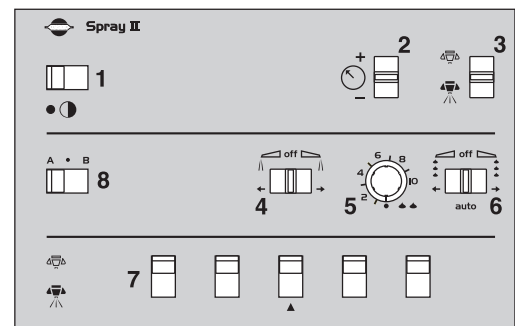

Spraybox II (TWIN only)

1. Power switch
2. Manual pressure regulation
3. Main ON/OFF
4. End nozzle (Left/OFF/Right)*
5. Foam marker regulation*
6. Foam marker ON/OFF*
7. Boom section valves
8. Valve function A-B*
9. Valve function C-D*
10. Air volume (TWIN only)
11. Air slot (TWIN only)

*optional equipment

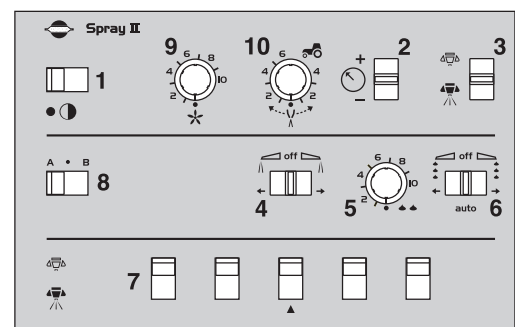

3 - Description

Tractor installation

Installation of control unit brackets

The supplied tractor pillar bracket (A) has a hole spacing of 3.9 in. (100mm) and 4.7 in. (120 mm). Check tractor instructions manual for information regarding attachment points.

Three tubes (B) are supplied. One, two or all three may be used. They can be bent and shortened. A spacer (C) is also supplied to allow further attachment possibilities. Find the best solution for your tractor or vehicle.

Tube (B) plate is staggered so all boxes will line up if correctly oriented.

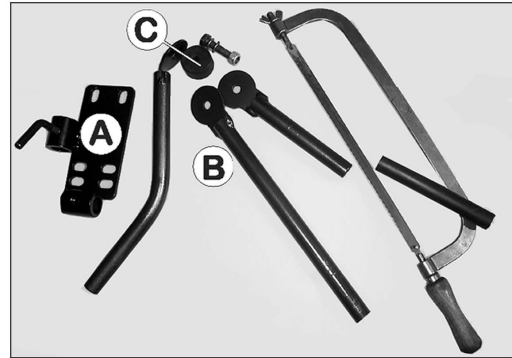

The recommended setup is to place the spacer (C) between the two tubes (B) used for the controllers. Place the 3rd tube (B) as shown in the picture, so it can be mounted in the bracket (A).



ATTENTION! An extension cable is available as an option if the Hydraulics control unit is to be placed further away from the EFC control unit. (Ref. no. 261933)



Power supply

The power supply is 12 Volt DC. Always note polarity!

Brown wire is positive (+)

Blue wire is negative (-).

Power supply must come directly from the battery. For proper function of the electric equipment, the wires must have the following gauge ratings and correct fuses to ensure sufficient power supply. The supplied power connectors follow the standard of most newer tractors. If using a tractor with another power connector, it is necessary to disassemble connector and fit it to the existing connector.

Use the HARDI® Electric distribution box (Ref. no. 817925) to ensure a good connection.

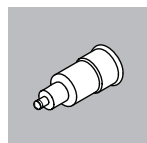
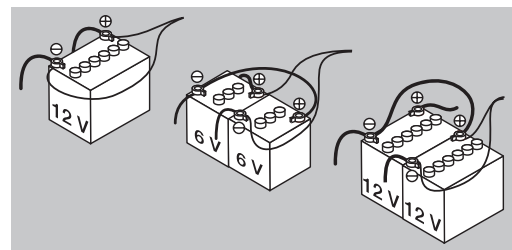

LIGHTER CONNECTOR

Spray control unit requires:
Wire 12 awg, Fuse 10 Amp
Hydraulic control unit requires:
Wire 10 awg, Fuse 15 Amp

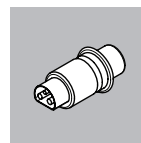

JOBCOM CONNECTOR

The unit requires:
Wire 8 awg, Fuse 25 Amp

4 - System setup



WARNING! Do not connect to the starter motor or generator/alternator. Warranty is void if this is done.



ATTENTION! See paragraph "System start-up" for more about connecting the controller.

Printer

If the 12 Volt printer is fitted, the supplied tube can be utilized to fit the printer on the Controller/Terminal brackets.



ATTENTION! The Controller/Terminal should be protected from moisture and should be removed when not in use if the tractor does not have a cabin.

Speed transducer for sprayer

The speed transducer is located at the inside of the sprayer's right wheel. It is an inductive type that requires a metallic protrusion to pass by it to trigger a signal. A speed ring is used to trigger the transducer. It should be adjusted so the transducer is placed in the center of the holes in the speed ring (vertical direction). Recommended distance between protrusion and transducer (A) is 1/8" to 1/4" (3 to 6 mm). Check throughout the entire circumference. Correct adjustment is indicated by a constant blinking from the transducer when the wheel rotates.

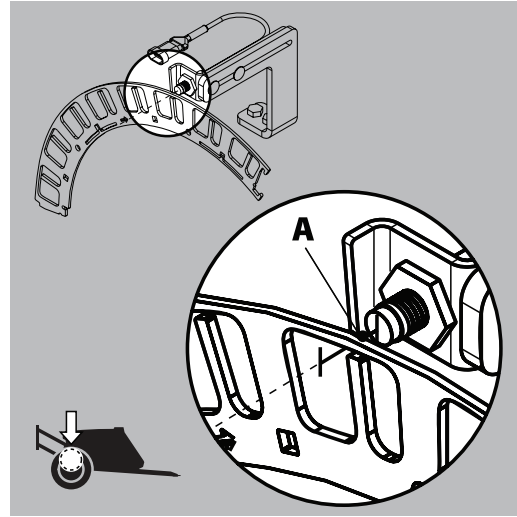

Speed transducer for tractor

It is possible to connect a speed sensor from the tractor gearbox or radar/GPS to the controller. A speed/switch harness (A) and extension cable are needed to connect the speed transducer to the Controller/Terminal.



Foot pedal remote ON/OFF (optional)

Note the following if the Foot pedal remote is to be fitted.

Remote ON/OFF switch has to be activated from the extended menu at installation. The HARDI® Service center does this.

The speed/switch harness (A) is connected to the Controller/Terminal. Connect the plug from the Foot pedal ON/OFF to the correct connector on harness (A).



ATTENTION! The main ON/OFF valve switch at Spray Box overrides all remote switches. It must be set to ON for the optional Remote ON/OFF switch to function.

4 - System setup

Initial system start-up

When connecting the 39 pin plug from the sprayer, note the one-way brackets inside the connector and connector plug. There are two different brackets to differentiate between the connector plug for the liquid (1) and hydraulic (2) boxes.

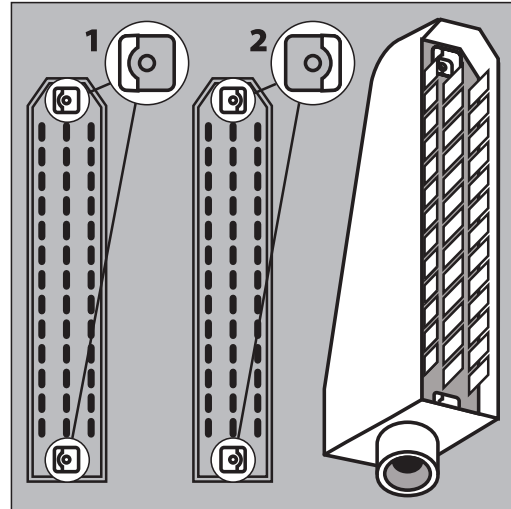

Hook the top of connecting plug first, then make sure lock tab (A) clicks in place to secure the plug in the socket.

When disconnecting the plug, the metallic tab (A) must be pushed back before the plug can be pulled out.

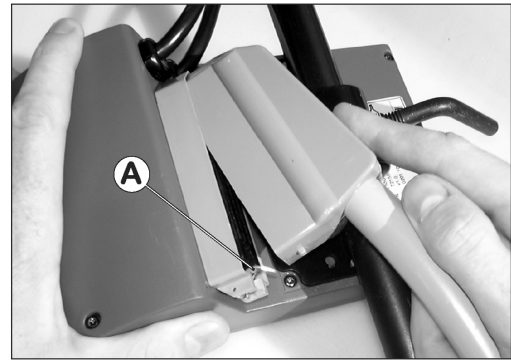

After connecting the plugs, the power is turned on at the Spray Box. Model, software version number, number of sections and size are displayed briefly. At initial start up, Controller also prompts for input of time and date. [Set clock to enable register].

Press  to continue.



ATTENTION! At first start-up the clock must be set in order to make the registers work properly. See "Menu 2.4 Set clock".

Screen contrast adjustment

The screen contrast can be adjusted by pressing  and then use the  or  to find the correct setting. This can only be done when "driving screen" is active, i.e. not when any menus are active.

Note that this function will only be available on hardware version 2.0 and higher

4 - System setup

Daily settings

System start-up

When the HC 5500 is turned on, a boot sequence is started while the controller is initiating itself. If the Controller is being put into operation for the very first time, it will prompt for date and time, [Set clock to enable register]. Please see "Menu 2.4 Set clock" for details on setting of clock.

During start-up, the display shows information about itself in the following order:

1. A screen shows that the controller is an HC 5500 and the current software version in the 3rd line of the display. In the 4th line of the display, a serial number for the specific controller is shown.
2. A screen shows boom width in the 3rd line of the display. Number of sections programmed into the controller are shown in the 4th line. This data should reflect the sprayer it is mounted to - if not, please contact your local HARDI® dealer to correct this.
3. If the sprayer is equipped with LookAhead and this is enabled in the HC 5500, it will prompt user for a nozzle choice - see section "LookAhead nozzle choice". If no LookAhead is available, this screen will not appear and the HC 5500 will be ready for use.

4. To prevent unintended Track movements, the track selection switch on the hydraulic control box must be set to "auto" if the HC 5500 is switched on while the boom is unfolded and/or the sprayer is steered out. The display will show that "auto" is on. If "auto" has not been selected, the controller will prompt you to select "auto" on. Press  to confirm this and then the controller is ready to use.

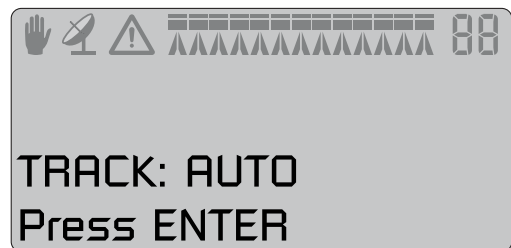
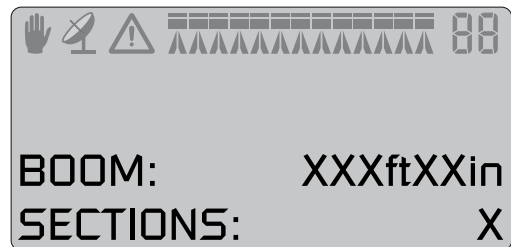
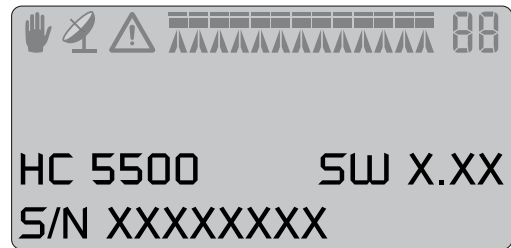



LookAhead nozzle choice

If LookAhead or pressure based regulation is enabled in the HC 5500, it will prompt user for a nozzle choice at every start-up of the controller. Display will show last used nozzle by displaying its color and ISO code in the display.

If the nozzle used during the last spray job is going to be re-used, then press .

Selecting another nozzle:

1. Select another nozzle by pressing  or .
2. Confirm the choice by pressing .

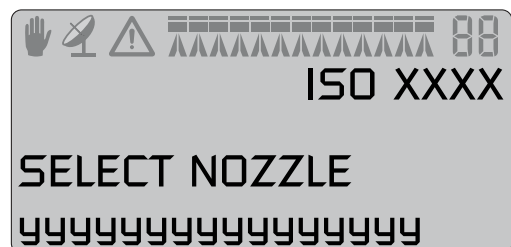

4 - System setup

3. If a selected nozzle holds no LookAhead calibration in the HC 5500 memory, then it should be calibrated - see section "Menu 3.7 LookAhead" in the chapter "Menu 3 Calibration".

Custom nozzle flow rate is also defined in "Menu 3.7.X LookAhead calibration".



Control units

Find a suitable place in the tractor's cabin to secure the control units from movement. Best recommended placement is to the right of the driver seat. The supplied bracket will fit most tractors. Threaded mounting holes may be hidden behind front corner cover.

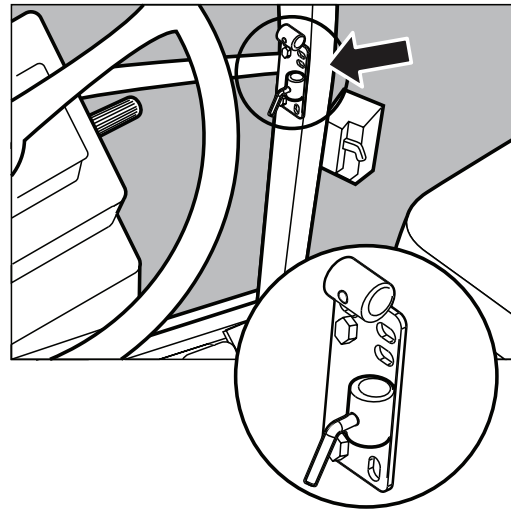





4 - System setup

Menu 1.1 Volume rate

How to change the volume rate

The volume rate can be changed by:

1. Setting the desired rate in the Controller.
2. Manually raising or lowering the pressure via the Spray Box.
3. In the menu: Pressing  or  to apply over or under in a preset percentage, e.g. 10% (the 3rd line indicates when this is active) or
4. When working (working screen): Pressing  or  to change to one of 3 preset volume rates.





To read the Volume rate:

Shortcut 

Press  and hold until menu [1.1 VOLUME RATE] is shown.

To change volume rate:

Move cursor with  or  to the value to be changed.

Use  or  to change the value.

Press  to confirm.

Press  and hold to exit the menu system.

If the volume rate is set up with 3 programmable rates, there are three possibilities to enter volume rate.

[1.1.1 Rate 1] (Default)

[1.1.2 Rate 2]

[1.1.3 Rate 3]

Manual dosage

To dose in manual mode, use the pressure switch on the Spray Box.

The manual mode is indicated by the  symbol at the top of the display.

To go from manual to preset volume rate, press .



ATTENTION! Under 0.3 mph (0.5 km/h), the Controller will not regulate automatically.

5 - Menu 1 Daily settings

Menu 1.2 Tank contents

To change the displayed Tank contents

Shortcut 

Press  and hold until menu [1.2 TANK CONTENTS] is shown.
The maximum size of the tank is displayed

Press  again and the tank contents maximum value is shown.

Press  or  to move the cursor to the value to be changed.

Press  or  to set the desired value.

Press  to confirm.

Press  and hold, to exit the menu system.

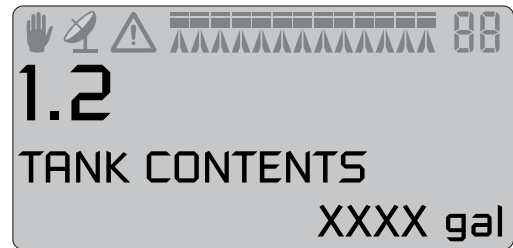

Menu 1.3 Select register

Menu 1.3.1 Register readout and selection

Register 1 to 98 can be used for individual areas.

Register 99 is a tally of register trips 1 to 98. They are identified with a number and it is also possible to name them. The active register is always visible in the upper right corner of the display. The data is saved when the system is switched off.



To read the totals of all registers:

Shortcut

Press and hold until menu [1.3.1 Register XX] is shown.

Press or to go to register 99. The number is shown on the 1st line and if present, the name on the 4th line.

Press to enter the register.

Press to scroll through the data.

Press and hold to exit the menu system.

To read the data in the active register:

Shortcut

Press and hold until menu [1.3.1 Register XX] is shown.

Press to enter register.

Press to scroll through the data.

Press and hold to exit the menu system.

To reset register:

Press and hold until the countdown has ended.

Reset of a register can be stopped if the key is released before countdown has ended.

To change the register:

Shortcut

Press and hold until menu [1.3.1 Register XX] is shown.

Press or to change the register.

The number is shown on the 1st line and if present, the name on the 4th line.

Press . If necessary, the register can be reset.

Press until the countdown has ended.

Press and hold to exit the menu system.



ATTENTION! The active register number is always visible in the upper right corner of the display.



ATTENTION! Naming of registers is done in menu 2.6.

5 - Menu 1 Daily settings

Menu 2.1 Display readout

General info



The following menu explanations assume you have mastered the general keystrokes and you can “find your way” to the specific menu. If this is not so, please re-read section “Keys”.

Menu 2.1.5 Work rate

It is possible to freely choose which function is to be shown on the 3rd or 4th line of the display. Choose the submenus of menu [2.1 Display readout].

Choose a submenu e.g. menu [2.1.5 Work rate].

Press  to confirm.

Use  or  to choose which line is to show data. Picture will change as shown.

Press  to confirm.



DISPLAY TEXT	DESCRIPTION
[2.1.1 Program: Actual]	Programmed and actual application rate
[2.1.2 Flow rate]	Flow rate out to the boom
[2.1.3 Optional sensor]	There are 8 sub-choices
[2.1.4 Time]	Actual time
[2.1.5 Work rate]	Rate shown in acres per hour
[2.1.6 Volume rate]	Actual rate in gallons per acre
[2.1.7 Tank contents]	Main tank contents
[2.1.8 Speed]	Driving speed
[2.1.9 Volume: Area]	2 readouts on the same line
[2.1.10 Active boom size]	Active boom size including end nozzle

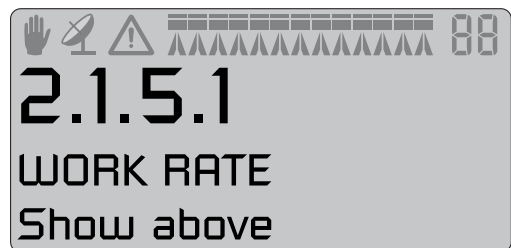

ATTENTION! As some readouts need extra sensors, the relevant sensor has to be connected to get a readout.

Menu 2.4 Set clock

How to set clock

If the Controller prompts for date and time, [Set clock to enable register]:

This must be done before the Controller is put into operation for the first time, otherwise no start and stop time will be recorded in the registers.



ATTENTION! If no prompt, the dealer may already have done this.

Press .

Press  to menu [2 Setup].

Press .

Press  to menu [2.4 Set clock].

Press  to enter menu [2.4.1 SET CLOCK].

Now you can choose between 24 hour or 12 hour clock with .

Press .

Set minutes, hours, year, month, day with  and .

Press  to confirm.

Press  and hold to exit menu system.

6 - Menu 2 Setup

Menu 2.5 Alarms

How to set up alarms

--Six different alarms can be set up. Choices are listed as follows.

DISPLAY TEXT	NOTES
[2.5.1 Volume rate]	Suggested setting is 10%
[2.5.2 Tank contents]	Measured in Gallons
[2.5.3 Spray pressure]	High/low pressure
[2.5.4 Fan speed]	High/low rpm
[2.5.5 Speed]	Speed max./min.
[2.5.6 Audio level]	0 = no sound, 5 is max. volume
[2.5.7 Sections off]	Sections switched to OFF

When outside the alarm parameters, the relevant warning will flash. The alarm beep can also be adjusted in audio level in menu [2.5.6 Audio level].

Example shows volume rate alarm for over or under application for more than 20 seconds.

Suggested setting is 10%. For no alarm, set at 0.

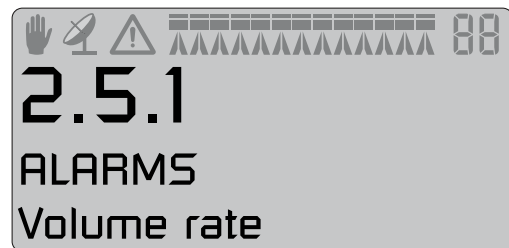

Menu 2.5.6 Audio level

It is possible to change the sound level for alarms.

Procedure:

Press

Press to menu [2 Setup].

Press .

Press to menu [2.5 Alarms].

Press .

Press to enter menu [2.5.6 AUDIO LEVEL].

Press .

Set the sound level by changing sound step with and .

Press to confirm.

Press and hold to exit menu system.



Menu 2.6 Register names

How to name the registers

If desired, the registers can be given names. Once set up, a name can be copied and edited.

Press or to toggle between [Yes] or [No].

Press if the name can not be copied or edited.

A "?" will blink on the 3rd line.

Menu 2.6.XX Copy name

Register number

Menu number

3rd line blinking

Character set

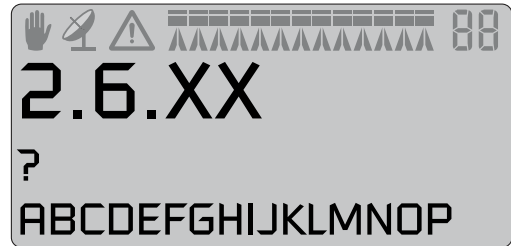

Moves "?" one step to right.

Moves "?" one step to left.

or Changes character set.

Activates cursor in 4th line exchanging with "?" in 3rd line.

Leaves the menu.

No effect.

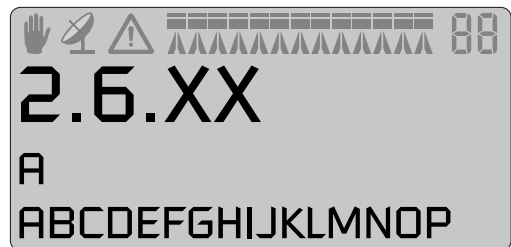

Assuming is pressed, "A" will blink in both 3rd and 4th line.

"B" will blink in both 3rd and 4th line.

"P" will blink in both 3rd and 4th line.

or Changes character set.

Selects character and returns to 3rd line.

The second letter can now be selected.

Press to select [Yes].

Press or to scroll through the defined names. The register number on the 1st line will change accordingly.

Press to select.

The name can be copied and edited. The blinking cursor is for editing.

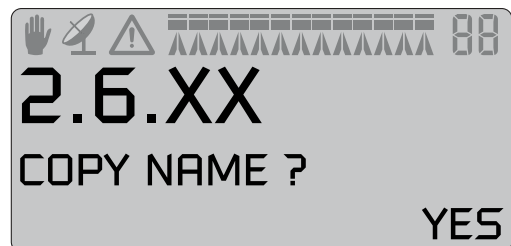



6 - Menu 2 Setup

Menu 3.1 Speed calibration

Menu 3.1.1 Sprayer

The calibration process is the same for each sensor type. In the following example a “speed sensor on sprayer” is used.

Shortcut 



1. Press  until menu [3.1.1 Sprayer] is shown.

It is possible to connect the speed sensor at different locations. See chapter 4 - System setup for more about this. They are calibrated in the following menus:

- [3.1.1 Sprayer] Speed sensor on sprayer
- [3.1.2 Tractor] Speed sensor on tractor
- [3.1.3 Radar] Radar speed sensor

2. Choose with the navigation keys.
3. Press  to confirm. The last confirmed sensor is the active speed sensor.

Shortcut 

4. Press  until menu [3.1.X “Speed abc”] is shown.
5. Choose speed transducer. (Sprayer, Tractor or Radar) [3.1.1 Sprayer]
6. Press  to confirm.
7. Press  to read PPU value.



ATTENTION! Be aware that even though tractor speed sensor and radar speed sensor use the same connector, the PPU value may be very different.

The speed transducer can be calibrated theoretically or practically. The practical method is recommended.

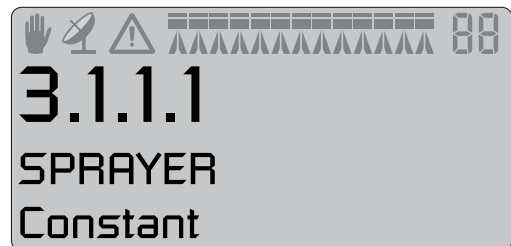
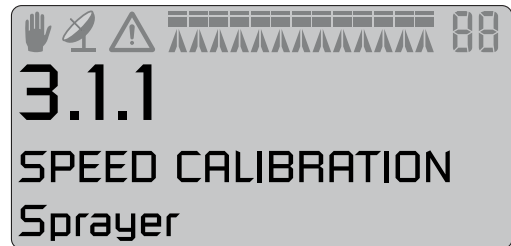

7 - Menu 3 Calibration

Menu 3.1.1.1 Constant

The theoretical speed constant, pulses per unit (PPU), is the distance in feet on the circumference of the wheel between holes (or protrusions / magnets) that the speed sensor records.

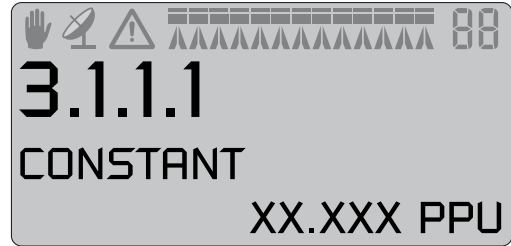

Menu 3.1.1.2 Practical

Practical calibration of speed is done by driving a measured distance and correcting the display so that the actual and the calculated distances are the same. Calibration should take place in the field with a half full tank and normal working tire pressure in order to obtain the wheel's real "working radius".

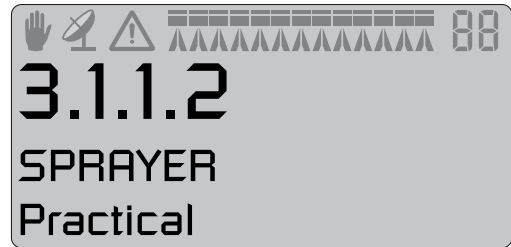

Method:

1. Measure a distance not less than 250 ft.
2. Park the tractor at the start of the measured distance.
3. Press . When zero distance [0 ft] shows, drive the distance.
4. Press .
5. Correct the distance shown on the display with the or to read the actual distance.
6. Press to confirm.



Menu 3.2 Flow calibration

Which method to use

The flow transducer can be calibrated theoretically or with two practical methods. The practical methods are preferred. Calibration is done with clean water. The Flow Tank method is time consuming, but is more accurate than the Flow Nozzle method.

When changing to nozzles with more than a 10% increase or decrease in output, it is recommended to recalibrate the flow transducer.

Calibration is recommended to be done at least once during the spraying season. Use the chart at the back of the book to record the values.

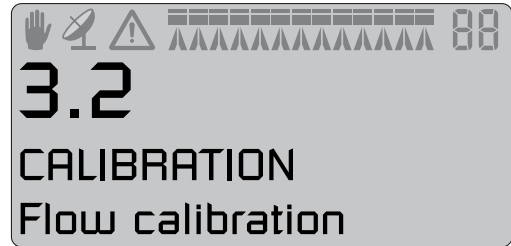

Menu 3.2.1 Flow constant

Use the navigation keys to change the flow constant theoretically.

Approximate PPU values for different flow housings are as follows in the table. Different flow housings are designated by groove (A).

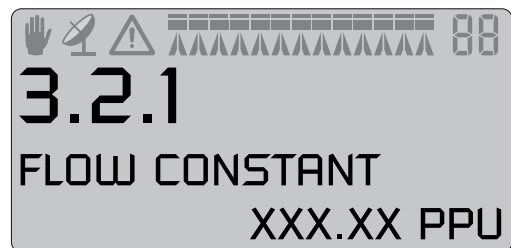

Housing	Housing identification (A)	Flow range	Orifice	PPU
		g/min	mm	value
S/67	One outside groove	2 - 30	13.5	485.00
S/67	No groove	4 - 70	20.0	225.00
S/67	Two outside grooves	20 - 160	36.0	475.00



ATTENTION! PPU indicates the number of pulses which theoretically come from the flow transducer while 1 gallon of liquid passes through.

Menu 3.2.2 Nozzle method

During practical flow calibration, the individual nozzle output on the display is compared to the actual individual nozzle output. The output displayed is corrected to read the actual output.

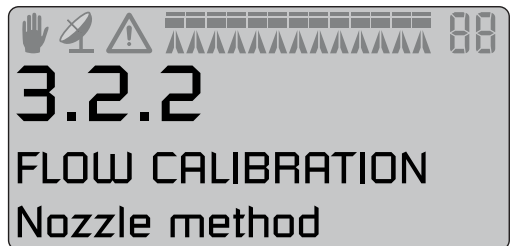



ATTENTION! See menu [3.3 Boom] if no boom data has yet been entered.

7 - Menu 3 Calibration

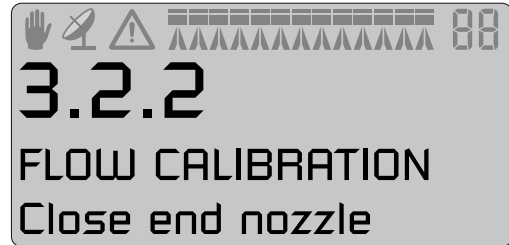
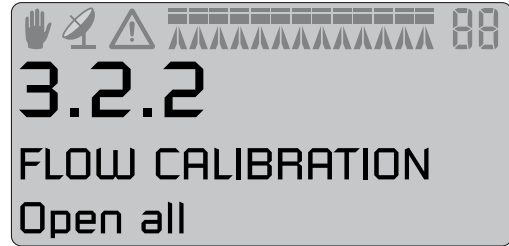
If a section has not been opened or an end nozzle is not closed, the warnings below (next 2 pictures) will show up in the lowest line on the display. If the boom symbol on the 1st line blinks, set menu [2.2.1 ON/OFF] to 0.0 mph.



Method:

1. Open all boom sections. Switch the main ON/OFF to ON. Close end nozzles (if fitted).
2. Go to menu [3.2.2 Nozzle method]. The display will then show the individual nozzle output per minute.
3. Using a HARDI® calibration jug, check the actual nozzle output per minute. It is recommended that an average of several nozzles be taken.
4. Press .
5. Correct the output shown on the display with the navigation keys to read the average output measured with the calibration jug.
6. Press  to confirm.

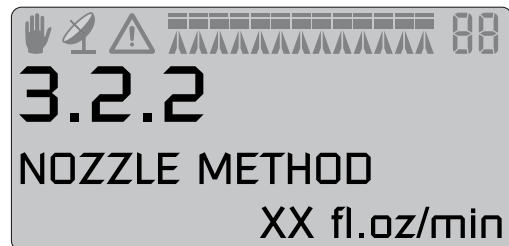

Menu 3.2.3 Tank method

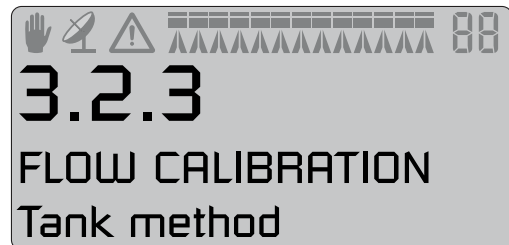

During practical flow calibration, the tank is partly emptied through the nozzles. While emptying, the display calculates the quantity emptied on the basis of the actual calibration value (PPU). The quantity displayed is compared with the quantity actually dosed.

This can be according to the tank contents level indicator or by weight difference before and after. The quantity displayed is corrected to read the quantity actually dosed.



7 - Menu 3 Calibration

Method:

1. Place the tank on level ground and fill it up with water until the level reaches a unique mark on the tank contents level indicator, e.g. 500 gallons.
2. Open all boom sections.
3. Go to menu [3.2.3 Tank method] and switch the main ON/OFF to ON.
4. Engage the P.T.O. The display- unit will then begin to count the volume being emptied through the nozzles.
5. When for example, 300 gallons have been emptied out, as shown by the tank contents level indicator, disengage the P.T.O. and switch the main ON/OFF to OFF.
6. Press .
7. Correct the volume shown on the display with the navigation keys to read the volume shown on the tank contents level indicator.
8. Press  to confirm.

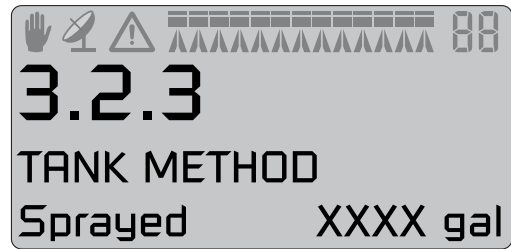

Menu 3.2.4 Circulation

The following is only relevant for sprayers equipped with circulation liquid system with 2 flowmeters. The circulation type liquid system has to be set up from the Extended menu at installation. The HARDI® Service center does this.

See menu [3.2 Flow calibration] for calibration of "Flow 1". Flow constant from "Flow 1" is shown.

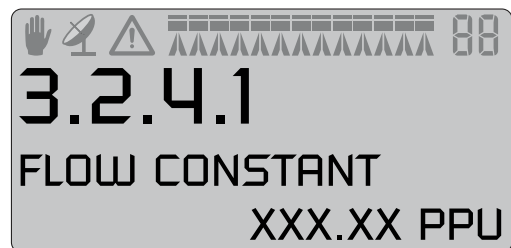

"Flow 1" is used as a reference when calibrating circulation flow, "Flow 2".

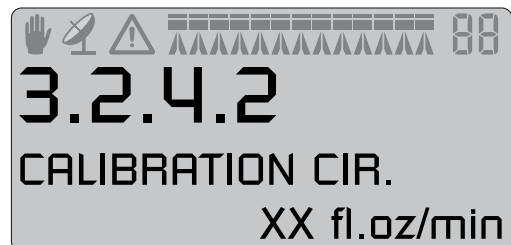

7 - Menu 3 Calibration

Method:

1. Ensure all boom sections and end nozzles are closed.
2. Go to menu [3.2.4.2 Calibrate circulation].
3. Press . The automatic calibration is initiated and line 4 will show "Calculating PPU".
4. When finished, the menu returns to [3.2.4.1 Flow constant] to show the new PPU.

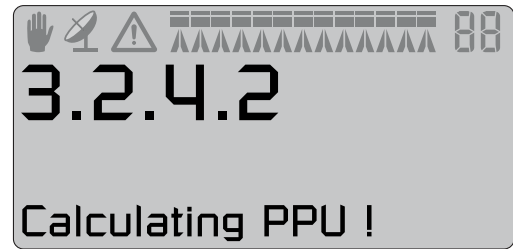

Menu 3.3 Boom

Menu 3.3.1 Width

Use the navigation keys to enter boom width.
Press  to confirm.

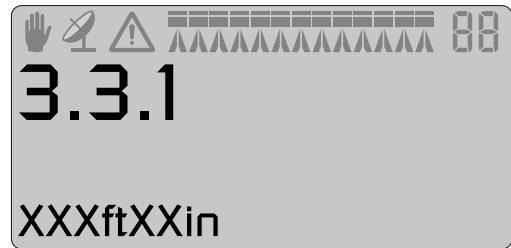

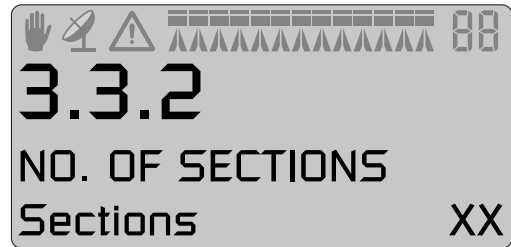

Menu 3.3.2 Number of sections

Use the navigation keys to set number of boom sections.
Press  to confirm.



Menu 3.3.3 Nozzles/section

Use navigation keys to set correct number of nozzles per section.
Press  to continue to next boom section.
Press  after the last section.



Menu 3.3.4 End nozzles (optional)

If end nozzles are fitted, set the value to the equivalent coverage by the boom nozzles. E.g. End nozzle coverage is 5 feet. This is equal to [03 Boom nozzles].

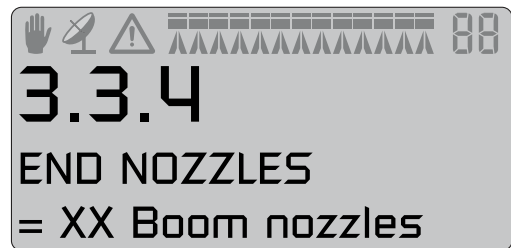

ATTENTION! It is important that the volume applied from the end nozzle matches the volume applied under the boom. This is a comparison of volume per minute per width. (Gallon/min/foot).

When the end nozzle is active, the area covered and volume sprayed is calculated and registered. If "Active boom size" is displayed, it will show an increase when the end nozzle is activated.

7 - Menu 3 Calibration

Menu 3.4 Regulation constant

Regulation constant

The sensitivity of the pressure regulation valve can be adjusted. Increasing the regulation constant will give a faster response on the pressure regulation valve. If the constant is too high, the valve will become unstable. There will also be excessive wear on the valve. The range is in percent. It is typically set between 30% to 50%.

Menu 3.5 Tank gauge

General info

This menu item is only present if the HARDI® Tank Gauge is fitted. For increased accuracy, it is recommended to do the flow calibration [3.2] before proceeding.

Present accuracy is up to +/- 13 gallons. This is at the widest liquid surface area in the tank. The smaller the liquid surface area, the more accurate the readout.







Menu 3.5.1 Adjustment

The correction factor for the specific gravity of the liquid sprayed can be set.

Default value is 1.000.

For liquid fertilizers, the specific gravity may range up to 1.3. The value in this case would be 1.300.

Method:

1. Press  to change value.
2. Use  and  to move cursor to the figure to be changed.
3. Change figure by pressing  and .
4. Repeat until all figures are correct. Confirm setting by pressing .

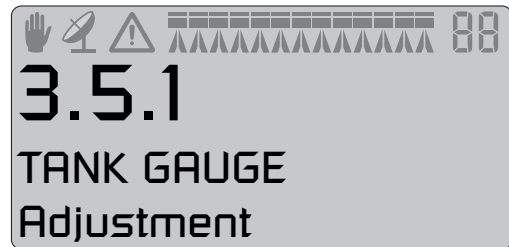

Menu 3.5.2 Total

This is for calibration of the HARDI® Tank Gauge. Go through the calibration step by step. A table with up to 100 data points corresponding to a correction value for each 25 mm of water level is created.

Method:

1. Fill the tank to the maximum level shown on the tank contents indicator.
2. Press .



7 - Menu 3 Calibration



3. Press  after ensuring the sprayer is level. Re-check actual contents if sprayer is re-levelled.



4. Open all boom sections and empty the tank. The pulses from the flow transducer are logged as data points. During this session the screen shows: [xxxx] as the actual water level in millimeters and [yyyyyy] is the number of pulses from the flow meter.



5. Press  when the tank is empty.

6. Correct the displayed volume with the  or  to the actual volume sprayed out.

7. Press . The new flow transducer PPU is calculated and the calibration of the HARDI® Tank Gauge is finished.



ATTENTION! Do NOT overfill. Overfilling will only register as maximum tank contents value.

Menu 3.6 Track

General info

There is no standard setting for the Track set up. The Track needs to be adjusted for different kinds of tractors, sprayers and spraying practices which can only be found under actual conditions.

For example; when spraying is done at high speed (10-15 mph), the Track must be set up so it reacts slowly and the dead zone could be higher than the standard setting.

In another example; when spraying at a relatively slow speed (4-10 mph) in a crop where the precision must be high, the dead zone can be reduced for more precision.

For each adjustment, it is described what happens if the setting is changed and what effect it will have on the sprayer.

Track

The Track is operated with the hydraulic control box. The following switches are used for this purpose:

- 11. Manual track switch
- 12. Track selection switches

The track selection switch (12) has 3 positions:

- 1. When the switch is in the lowest position, the sprayer will align to be in position for folding the boom.
- 2. When the switch is in the middle position, the system is in auto and the sprayer track will follow the track from the tractor.
- 3. When the switch is in the upper position, the system is in manual, and switch (11) can be used for steering the sprayer right and left.

If unsafe driving occurs, an alarm will be triggered, and the sprayer will align. Press  to turn alarm off. Switching to "manual" (12) or pressing "align" (12) will also turn the alarm off. Be aware that the alarm can not be turned off as long as unsafe driving still occurs!



ATTENTION! When driving in hilly terrain (crab walk) in auto mode, the manual steer button (11) can be used to optimize the tracking. Before reaching the headland, switch the track selection switch (12) to manual and back to auto to neutralize the offset.

Before folding, the track selection switch (12) must be set in the "align" position before any boom folding takes place. Failure to do this will cause an alarm signal when pressing a folding switch. Press track selection switch (12) down to align the sprayer and re-start the folding procedure.

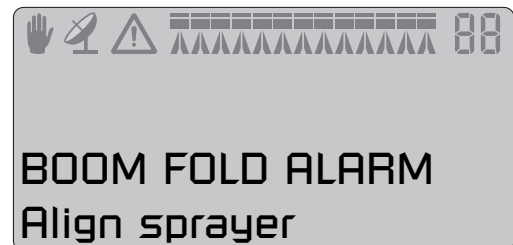
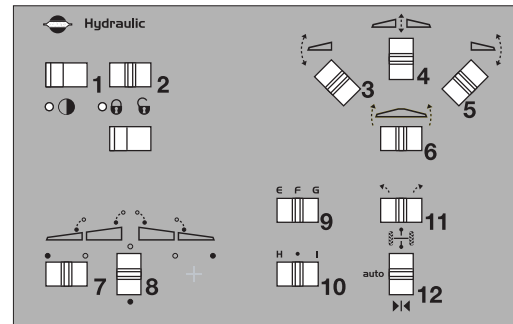

7 - Menu 3 Calibration

Reversing the sprayer

When reversing the sprayer, the controller will prompt “Reversing” in the display. When the track is in “auto” mode, the track will lock in the position it had when the tractor was stopped. This means that the same steering angle, if any, will be kept when the sprayer is reversed.

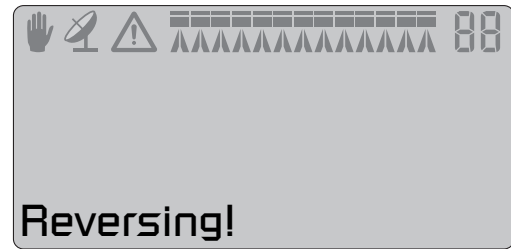

Menu 3.6.1 Track width

Here the track width can be entered. The track is measured from right side tire center to left side tire center of the sprayer wheels. It is important that the right track width is entered. The controller will calculate the speed to the center of the machine and not the speed of the wheel.

If the track width is incorrect, it will influence the track precision and the safety factor.

Factory setting: 71 in

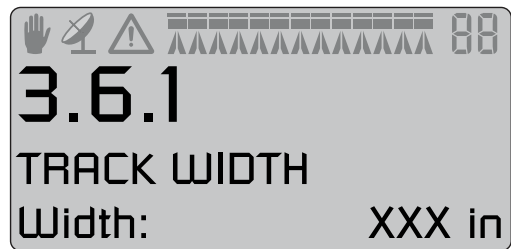

Menu 3.6.2 Tractor drawbar

Here the length of the tractor drawbar is entered. The measurement is from the center of the tractor rear axle to the center of the drawbar pin. This has to be adjusted every time a new tractor is hooked up to the sprayer. When hooked up, check the rigidity of the tractor drawbar mounts. There must be no sideways movement.

Factory setting: 31 in

Measurement too short: The Track reacts faster, but will make the sprayer steer too large a curve.

Measurement too long: The Track reacts slower, but will make the sprayer steer too short a curve.

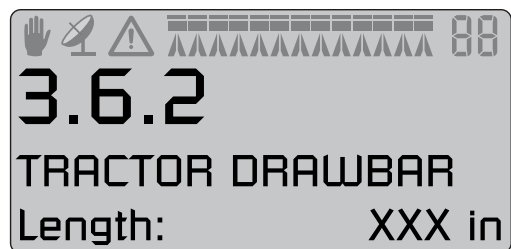

Menu 3.6.3 Dead zone

This is the non regulation zone when the sprayer is straight behind the tractor. If the sprayer is oscillating in the hydraulics when driving straight, this value must be increased.

Factory setting: 2 in

Over 6" not recommended.

Decreasing value:

Reacting on small deviations. Tendency to oscillate that will damage the boom. High precision, but more unstable driving with small corrections all the time.

Increasing value:

No oscillation, but tendency to sway. Low precision, but very steady driving with less corrections.

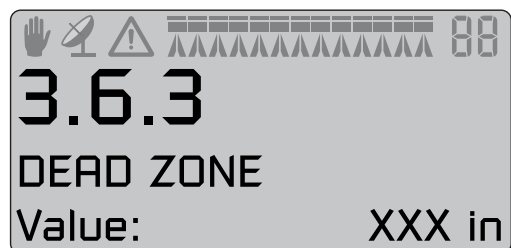

Menu 3.6.4 Damping

If the system is too aggressive, the damping constant must be increased. Failure to do so may damage the boom.

Factory setting: 50%

No damping (0%): High precision, but very unsteady. Fast reaction time, but more aggressive movement that potentially can damage the boom.

Full damping (100%): Low precision, but very steady. Slow reaction time, but less aggressive.

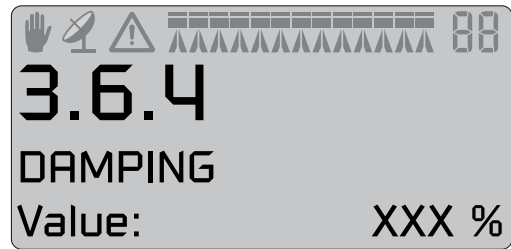

Menu 3.6.5 Alignment offset

Here the fine tuning of tractor and sprayer alignment is done. This is to compensate if the front potentiometer is placed offset to the centerline when the sprayer is attached.

Note +/- can be changed with and .

Factory setting: 0"

Negative setting will move the sprayer to the left of the track, and positive setting will move the sprayer to the right of the track. The sprayer must follow the tractor in a straight line in all situations. If the value is over 4" (10 cm), it is recommended to manually adjust position of the front angle sensor.



Menu 3.6.6 Sensitivity

The purpose of this menu, is to adapt the track regulation to the tractor hydraulics and to the characteristics of the sprayer hydraulics system. Preferably this is done in the field.

Calibration procedure is divided into 4 steps where an offset and gain value is found to both left and right movement, 4 values in all.

Method:

1. Unfold boom and without driving, set P.T.O. to spraying R.P.M.
2. Press down the track mode button to align sprayer and then set the track mode button into middle position to enable "auto" at the controller.

First left/right offset is found:

3. Go to menu [3.6.6 Sensitivity] and select "Yes" with or and press . Calibration starts.

4. Press and hold the manual track button to the direction indicated by the arrow in the display. Display will show an increasing percentage ending with an "OK" when offset is found.

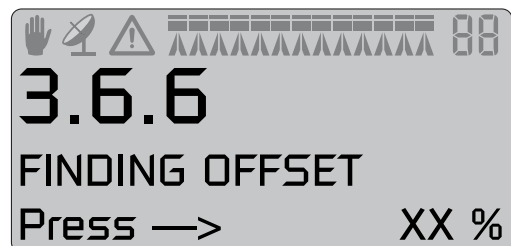

7 - Menu 3 Calibration

5. Afterwards same procedure is repeated for opposite direction.



ATTENTION! If value has not been reached by 40 %, the display will read "Fail!". Accept this by pressing . Then increase hydraulic oil flow from tractor and retry calibration again.

The calibration automatically continues with gain calibration:

6. Press and hold the manual track button to the direction indicated by the arrow in the display. Display will show a counting percentage ending with an "OK" when gain is found.



7. Afterwards same procedure is repeated for opposite direction.



8. The display reads "CALIBRATION OK" when calibration has finished. Confirm and leave menu by pressing .

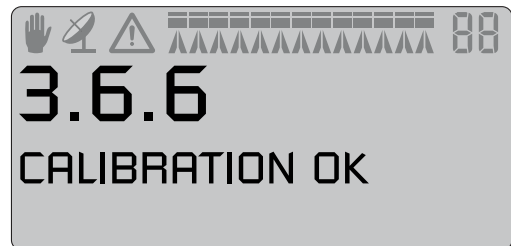

Emergency Track

If a problem with the Track should occur, please see "Menu 4.7 Emergency Track"



Menu 3.7 LookAhead

Menu 3.7.X LookAhead calibration

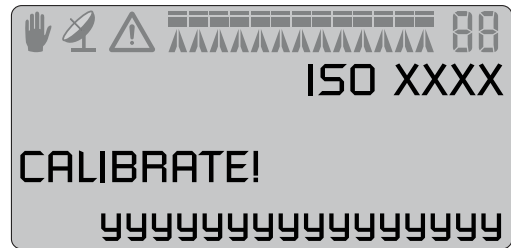
At start-up of the HC 5500, the user is prompted for a nozzle choice. If the selected nozzle holds no LookAhead calibration in the HC 5500 memory, it will need to be calibrated. Press  to enable "auto" mode prior to calibration.



Calibration method:

1. Press  to begin calibration. Enter an application rate in the display suitable for the nozzle.
2. Confirm by pressing .

Two spraying speeds for calibration are now calculated in the HC 5500.

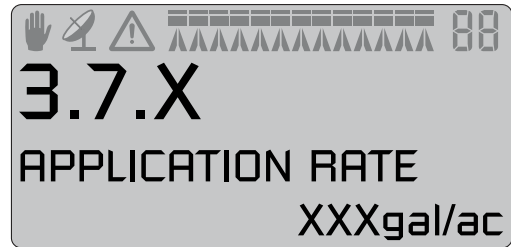

3. Start spraying at the suggested speed shown in the 3rd line. Speedometer in 4th line of display shows actual speed.

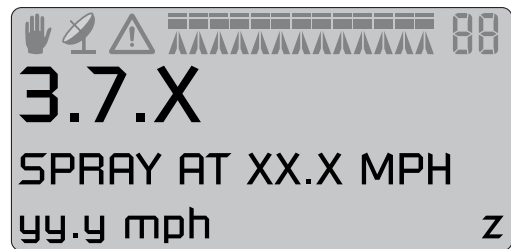

4. While spraying at suggested speed, a digit in lower right corner of display is counting up to 9. If calibration value is found, "ok" is shown in the display. If a value is not found, the digit starts re-counting up to 9 until a value is found.

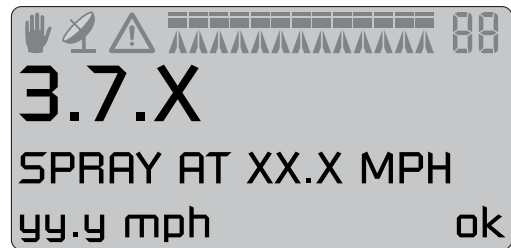

5. Another suggested speed is now shown in the display. Repeat steps 3 and 4 again for this 2nd suggested speed.
6. The digit in lower right corner counts up as explained in step 4. But when a value is found this time, "done" will be shown in the display since calibration has now finished.
7. Leave calibration by pressing .

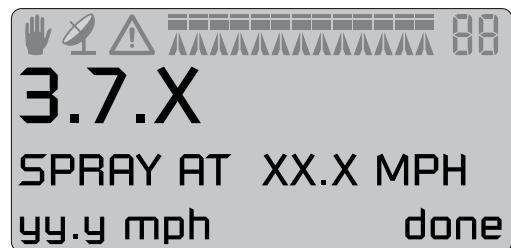

7 - Menu 3 Calibration

If custom nozzle LookAhead calibration is selected, the flow at 43.5 PSI (3 bars) must first be defined.

1. Enter value.
2. Confirm by pressing .
3. Do all the above calibration routine as usual.

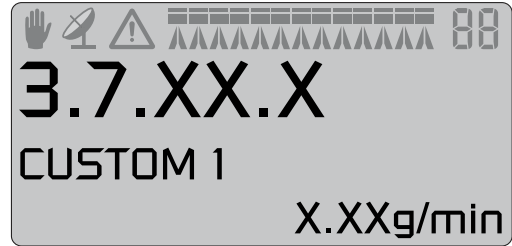

ATTENTION! To calibrate, the speed must exceed the minimum speed set in the controller memory. If minimum driving speed is set too high, please contact your local HARDI® dealer.



ATTENTION! If all section valves are turned off, then LookAhead is in standby. When turning single sections off, the last valve must be turned off by using the main on/off.



ATTENTION! During the entire calibration process, the fluid system should be in "Auto" mode. If not, press  to enable it.



ATTENTION! When using very large nozzles, it could be necessary to reduce speed until application rate is stable.



ATTENTION! If controller suggests a speed lower than min. regulation speed, then choose a higher application rate.

Menu 4.1 Measure

Trip meter

This is a simple electronic trip meter. You can measure distance. If the implement width is entered in menu [4.1.3 Working width], area can also be measured in menu [4.1.2 Area].

Use  to clear the value.

Menu 4.2 Service intervals

Menu and intervals

Service intervals and a nozzle check are programmed into the Controller. This makes it easier for the operator to remember the service intervals.

From the factory, the Controller is set up with three service and a nozzle check reminder.

Menu & interval	Hours	Action
[4.2.1 Interval A]	10	See sprayer instruction book, Maintenance.
[4.2.2 Interval B]	50	See sprayer instruction book, Maintenance.
[4.2.3 Interval C]	250	See sprayer instruction book, Maintenance.
[4.2.4 Interval D]	-	Not defined from factory.
[4.2.5 Nozzle]	50	Check flow rate. Change nozzles if more than 10% of rated flow.

Entering the above menu's will display the hours remaining until next service.

The importer or dealer may have added Interval D. If no interval is set, [D Not defined] is shown.

Press  to register service or control, if displayed when switched on.

The warning  will remain present until the service interval is reset.

Service interval reset

To reset service interval, go to relevant interval [4.2.X Interval X or Nozzle].

Press  to reset hour meter.

Press  to confirm.

X = Variable values here

8 - Menu 4 Toolbox

Menu 4.3 Stop watch

Use as timer

The clock can be used as a timer.

Press  to start and stop.

Use  to clear the value.

Menu 4.4 Alarm clock

How to use alarm

The clock can be set to give an alarm when the time is reached.

Press  or  to set alarm and confirm with .

Menu 4.5 Test

How to test

All readouts for the transducers are in accumulated counts, i.e. one signal gives one count, except for the optional (analog) transducer that is read in milli-ampere.

Go to menu [4.5 Test]. Choose the item to be tested and open the menu. Activate sensor and see if the signal is detected.

[4.5.1 Flow]. Enter this menu to test the flow sensor.

[4.5.2 Speed].

[4.5.3 Optional sensor].

[4.5.4 Active switches].

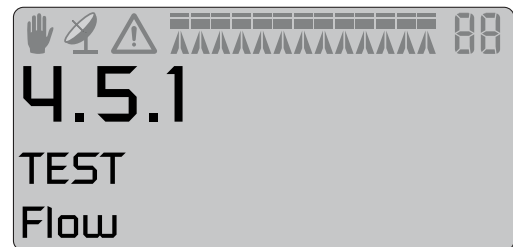

Menu 4.6 Speed simulation

How to use speed simulation

Speed may be simulated for certain purposes. A two figure value may be entered. The state remains valid until the Controller is re-started or the value is set to "0".

Menu 4.7 Emergency Track

Emergency Track

When this menu is entered, the “bypass” function is active so that all sensors are ignored. The system can be operated manually so it is possible to fold the boom and drive home. In the menu, the sensor voltages can be checked, which is useful for HARDI® service to solve the problem.

F: Front potentiometer

R: Rear potentiometer

L: Lock sensor (no sensor reads 00.0 Volts)

B: Boom sensor

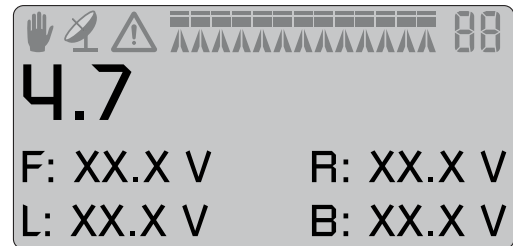

Lock sensor:

If the lock sensor indicates “released” (high voltage) and the track selection switch is in either “auto” or “manual”, it is possible to use the “Left/Right steer” and “Fold inner in” switches regardless of any other inputs the Controller receive from sensors.

If the lock sensor indicates “locked” (low voltage) and the track selection switch is in either “auto” or “manual”, it is possible to use “Fold inner in” switch regardless of any other inputs the Controller receives from sensors. Manual or automatic tracking is not possible.

If the track selection switch is switched to “align”, the trapeze lock will attempt to lock regardless of any sensor reading. No automatic align is attempted. Manual or automatic tracking is not possible.

Once the boom is folded into transport position, exit the menu. This will activate the track lock if it is not damaged. As an extra security, switch power to HC 5500 to OFF and stop oil flow to the sprayer.



DANGER! Emergency only. Don't track with the boom folded! Safety system is disabled.



ATTENTION! Note this menu is only shown if Jobcom hardware is fitted, and the software is enabled.

8 - Menu 4 Toolbox

Menu 5.1 Print

What you can print

This menu has to do with dumping and printing of data.

The following can be printed via the 12 volt printer.

[5.1.1 Register number] A specific register

[5.1.2 All registers] Register 1 to 99. Only active ones will be printed.

[5.1.3 Configuration] This records all the parameters of the Controller.

Two examples of printouts are shown. To the left is a printout of a specific register (menu 5.1.1). To the right is a printout of the configuration (menu 5.1.3).

HARDI HC5500		HARDI HC5500 - configuration	
Serial number	03011211	Serial number	03011211
Register	5 / MOUNT CLAY	SW version	152
Volume applied	1135 L	Register	0
Area	11.36 ha	Total volume applied	8768 L
Travelled spray distance	5.7 km	Total area	91.79 ha
Start date	31.07.03	Total travelled spray distance	37.4 km
Start time	12:19	Start date	01.07.03
Stop date	31.07.03	Stop time	08:50
Stop time	13:27	Stop date	06.08.03
Time used (spraying time)	01:08	Stop time	06:22
Work rate	9.94 ha/h	Total time used (spraying time)	05:11
Average spray speed	4.9 km/h	Total work rate	17.70 ha/h
Max. spray speed	5.3 km/h	Total average spray speed	7.2 km/h
Average volume rate	100 L/ha	Total max. spray speed	14.0 km/h
Date printed	06.08.03	Total average volume rate	96 L/ha
Time printed	16:18	Programmed volume rate	0 L/ha
Notes:		Selected register number	5
		Auto ON/OFF, speed threshold	Off
		VRA remote ON/OFF	Off
		Clock set up	24
		Optional sensor 1	Pressure
		Optional sensor 2	Revolution
		Alarm volume rate	+/- 0 %
		Alarm tank contents	0 L
		Alarm optional sensor 1	0/ 0
		Alarm optional sensor 2	0/ 0
		Alarm speed max.	0.0 km/h
		Alarm speed min.	0.0 km/h
		Alarm sections off	Disable
		Audio level	0
		Sprayer speed PPU (active)	6.000 PPU



ATTENTION! For configuration printout, total area and total average volume rate values are not relevant.

9 - Menu 5 Logbook

Menu 5.2 Data dump

How to dump data

Enables data dump to an office printer. This could be done for example, by using the Hyper Terminal function in Microsoft Windows. Note the Hyper Terminal has to be activated and a communication cable (ref. no. 72271600) and 12 volt power supply to the Controller and Spray Box is needed.

The Hyper Terminal baud rate should be set at one of the following before transmitting data:

19200 baud

9600 baud (HC 5500 default)

4800 baud

2400 baud

1200 baud

If only the display unit is to be removed from the tractor, a 12 Volt power supply cable (ref. no. 72244500) is necessary.

The following can be printed to an office printer.

[5.2.1 Raw data]

[5.2.2 With header] Permits data to be set up with a column header.

[5.2.3 Config]

Off-season storage

Storage

When the tractor and sprayer is parked, disconnect the power supply to the Spray Box. This will stop the system from using power.

The Controller and Spray Box should be protected from moisture and should be removed if the tractor does not have a cabin.

Emergency operation

In an emergency situation

The Spray Box can operate the control unit without the Controller. If you suspect the Controller is faulty, disconnect it from the Spray Box. Spraying can now be continued. If the fault persists, it is not the Controller.

11 - Fault finding

Operational problems

Operational faults

FAULT	PROBABLE CAUSE	CONTROL/REMEDY
Area is not being measured.	Boom width or speed constant have not been entered.	Enter the values in menu [3.3.1 Width] and [3.1 Speed calibration].
	Missing speed sensor.	Check the sensor using menu [4.5.2 Speed], check the cable to the sensor for damage. If necessary, replace the sensor. Check sensor location [3.1 Speed calibration].
The volume rate gpa is continuously displayed at "0".	Constant has not been entered.	Enter constant in menu [3.2.1 Flow calibration].
	Pulses of the flow meter are not reaching the sprayer control unit.	Check wiring. Check the impeller of the flow meter, using menu [4.5.1 Flow] - it may be stuck.
The volume rate display is not correct.	The flow meter is not working properly.	Test the flow meter using menu [4.5.1 Flow].
	The area is not being registered.	Check boom width and adjust if necessary. Re-calibrate speed [3.1 Speed].
The intended volume rate cannot be reached. The volume is below the pre-set rate.	The pressure motor has been incorrectly poled. The rate is controlled downwards instead of upwards.	Check the control by using the +/- keys in manual mode. Change the control motor connections if necessary.
	The pump cannot deliver the required amount. The filters are blocked.	Increase PTO speed. Change to a lower gear. Clean the filter.
	Wrong flow PPU.	Check PPU using menu [3.2 Flow calibration].
The volume rate lies above the pre-set rate.	The pressure motor has been incorrectly poled. The rate is controlled downwards instead of upwards.	Check the control by using the +/- keys in manual mode. Change the control motor connections if necessary.
	The return flow from the pressure motor to the tank cannot take superfluous quantity.	Check the tube system. Reduce the power of the pump (lower PTO speed, higher gear).
Volume application rate not stable when only one or two boom sections are open.	Flow below minimum frequency of flow transducer.	Set pressure manually when spraying with fewer sections. Install a pressure transducer. Under 5 Hz from the flow transducer will result in the system switching to pressure based sensing for volume application rate.
SafeTrack not responding.	Sensor not reading correctly.	Check menu [4.7 Emergency track] and correct sensor distance, replace sensor.
	No speed signal.	Check sensor using menu [4.5.2 Speed].

11 - Fault finding

Mechanical faults

FAULT	PROBABLE CAUSE	CONTROL/REMEDY
No speed readout.	Incorrect speed sensor location chosen.	Select the correct sensor on Sprayer, Tractor or Radar in menu [3.1.1 , 3.1.2 or 3.1.3].
	Defective sensor cable.	Check sensor using menu [4.5.2 Speed].
Error message that fuse is active.	Short circuit in system. The Spray box has 3 thermal fuses:	Turn power OFF and locate problem. When fuses have cooled down, the system can be powered on again.
	Fuse 1 = Section valves to left side of center and center switch.	
	Fuse 2 = Section valves to right of center switch.	
	Fuse 3 = Short circuit in options and pressure regulation.	
Error message "Low voltage".	Voltage below 9 Volts.	Check battery and connections.
Speed readout not stable.	Perforated wheel transducer plate fitted back the front.	Relocate transducer.
	Speed transducer set too close to upper or lower sides of perforated wheel sensor plate.	
Attempt to release lock, but no "release" signal from lock sensor.	No hydraulic pressure.	Check pressure from tractor.
	Misadjusted lock sensor.	Adjust sensor gap to lock to max. 3/16" (5 mm).
	Mechanical defect.	Replace defective parts.
Attempt to lock, but no "lock" signal on sensor input.	Lock sensor misadjusted. Mechanical defect prevents lock to penetrate hole. Misadjusted rear angle sensor.	Adjust lock sensor gap to max. 3/16" (5 mm). Replace defective parts. Adjust rear angle sensor to center.
Lock is detected released unintentionally.	Poor lock sensor adjustment. Lock cylinder fallen off.	Re-fit new lock cylinder. Adjust lock sensor gap to max. 3/16" (5 mm).
Lock is detected released.	Hydraulic pressure established. Misadjusted lock sensor.	Adjust lock sensor gap to max. 3/16" (5 mm).
Lock is detected locked unintentionally.	Missing hydraulic pressure on lock cylinder.	Check pressure from tractor.
	Misadjusted lock sensor.	Adjust sensor gap to lock to max. 3/16" (5 mm).
No lock release when hydraulic pressure is established, and the HC 5500 is powered up.	Hydraulic pressure hoses P and T are turned around.	Turn hydraulic pressure around. T = green P = red.
Power to Jobcom.	Power supply not sufficient. The power cable to the Jobcom has to be an unbroken power line from the battery.	The cable from the battery to Jobcom has to be 10 awg. Fit 72266300 tractor power cable. The fuse on the cable has to be 25A.
Rear angle sensor alarm.	In menu 4.7 the rear angle sensor will read app. 0.02 Volt.	Check 10A fuse on DAH PCB in the Jobcom. Check sensor cables for damage.

11 - Fault finding

FAULT	PROBABLE CAUSE	CONTROL/REMEDY
Unable to lock the SafeTrack.	The back angle sensor possibly needs adjustment.	Place a 5/8" bolt (16-17 mm) in the calibrating hole on the lock. Then adjust the rear angle sensor to 2.50 Volt.
Alarm # 1	Lock is locked, but it should be open.	Activate tractor hydraulics. Check/adjust lock sensor. Mechanical defect.
Alarm # 2	Attempted to lock, but lock sensor signals not achieved.	Check/adjust lock sensor. Mechanical defect. Check/adjust angle sensor.
Alarm # 3	Lock is detected released unintentionally.	Poor lock sensor adjustment. Lock cylinder fallen off.
Alarm # 4	Lock is detected released unintentionally.	Missing hydraulic pressure on lock cylinder. Misadjusted lock sensor.
Alarm S1 - S13	Section valve defective.	Change valve.

12 - Testing and fine tuning

Testing and fine tuning

Fine tuning the flow constant - PPU

Calibration of the flow transducer is carried out with clean water but small changes may occur when adding pesticides or fertilizer. This will effect the final readings. This is typically noted when the volume displayed on the display does not equal the actual known volume that was sprayed out. The formula below can be used to "fine tune" the flow transducer PPU.

New PPU = (Original PPU x Displayed Volume) / Sprayed Volume

For example, the spray tank is filled with 1000 gallons of spray liquid. When sprayed out, the display showed a total of 900 gallons. (Original PPU = 485.0)

New PPU = (485.0 (Original PPU) x 900 (Displayed Volume)) / 1000 (Sprayed Volume) = 436.5

Note the relation is inverse:

* To raise the displayed volume, the PPU is lowered.

* To lower the displayed volume, the PPU is raised.

Pin & Wire connection

AMP Super Seal	Box	Color coding
2	+	Brown
3	Sig.	Blue
1	-	Black

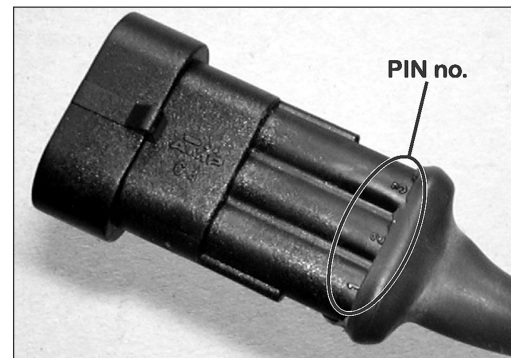

Testing flow transducer

BROWN wire to positive of 12 volt battery.

BLACK wire to negative.

BLUE wire to multimeter positive.

1. Check the rotor turns freely.
2. Each vane in the rotor has a magnet in it with the pole facing out. Check that the 4 magnets are present.
3. Use a magnet to check that every other magnet in the rotor has the same pole orientation. The rotor magnets must be N - S - N - S.
4. Connect negative from multimeter to negative of battery.
5. Set multimeter to DC volt.
6. By turning the mill wheel slowly, this will register approx. 8.0 +/- 1 volt with the diode on and 0.3 +/- 0.1 volt with the diode off with every second magnet.

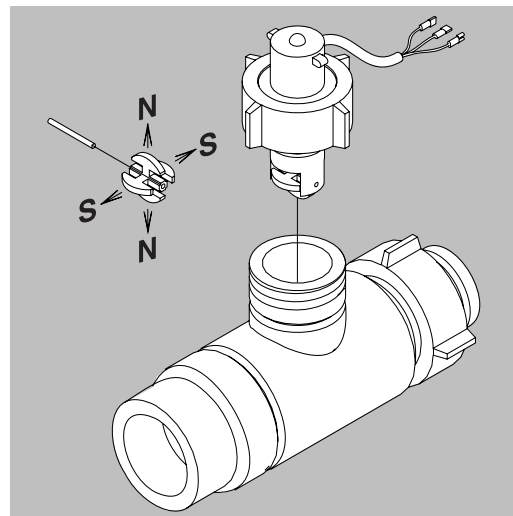

12 - Testing and fine tuning

Testing speed transducer

BROWN wire to positive of 12 volt battery.

BLACK wire to negative.

BLUE wire to multimeter.

1. Connect negative from multimeter to negative of battery.
2. Set multimeter to DC volt.
3. Bring a metallic object within 1/8" to 3/16" (3 to 5 mm) from the transducer. This will register 1.4 +/- 0.2 volt and the diode will turn on.
4. By removing the object, this will register 12.0 +/- 1.0 volt. Diode is OFF.

Specifications

Specifications

Supply voltage:	12 Volt DC
Controlled shutdown "low battery":	9 Volt DC
Maximum supply:	16 Volt DC
Maximum peak:	28 Volt DC
Ambient temperature:	23°F to 158°F (- 5°C to + 70°C)
Memory:	Flash PROM non-volatile
Digital transducers (option 2, 3 and 4):	Square signal
Frequency:	0.5 Hz to 2 kHz
Trigger high:	4.0 to 12.0 Volt DC
Trigger low:	0.0 to 2.0 Volt DC
Analog transducers (option 1)	
Supply:	12 V
Input:	4 to 20 mA
Minimum speed for volume regulation	0.3 mph (0.5 km/h)

Flow ranges for the flow transducers

Housing	Housing identification (A)	Flow range	Orifice	PPU
		g/min	mm	value
S/67	One outside groove	2 - 30	13.5	485.00
S/67	No groove	4 - 70	20.0	225.00
S/67	Two outside grooves	20 - 160	36.0	475.00

Baud rate

The Controller is capable of running the following baud rates when transmitting data to an external component via the RS232 connectors:

19200 baud

9600 baud (HC 5500 default)

4800 baud

2400 baud

1200 baud

13 - Technical specifications

Materials and recycling

Packaging information

Materials used for packaging are environmentally compatible. They can be safely deposited or they can be burnt in an incinerator.

Disposal of electronics

Cardboard: Can recycle up to 99% and therefore should be put into the waste collection system.

Polyethylene: Can be recycled.

When the operating unit has completed its working life, it must be thoroughly cleaned. The synthetic fittings can be incinerated. The printed circuit boards and metallic parts can be scrapped.

13 - Technical specifications

Charts

Chart for recording values

Menu	Function	1 - Values	2 - Values	3 - Values
[3.2.1 Flow constant]	Flow PPU			
[3.1.X.1 Speed constant]	Speed PPU			
[3.4 Regulation constant]	%			

13 - Technical specifications

Warranty policy and conditions

HARDI® NORTH AMERICA INC. , 1500 West 76th Street, Davenport, Iowa, USA; 8550 W. Roosevelt Avenue, Visalia, California, USA and 337 Sovereign Road, London, Ontario, Canada hereinafter called "HARDI®", offers the following limited warranty in accordance with the provisions below to each original retail purchaser of HARDI® new equipment of its own manufacturer, from an authorized HARDI® dealer, that such equipment is at the time of delivery to such purchaser, free from defects in material and workmanship and that such equipment will be warranted for a period of one year from the date of delivery to the end user providing the machine is used and serviced in accordance with the recommendations in the Operator's Manual and is operated under normal farm conditions.

1. This limited warranty is subject to the following exceptions:
 - a) This warranty will be withdrawn if any equipment has been used for purposes other than for which it was intended or if it has been misused, neglected, or damaged by accident, let out on hire or furnished by a rental agency. Nor can claims be accepted if parts other than those manufactured by HARDI® have been incorporated in any of our equipment. Further, HARDI® shall not be responsible for damage in transit or handling by any common carrier and under no circumstances within or without the warranty period will HARDI® be liable for damages of loss of use, or damages resulting from delay or any consequential damage.
2. We cannot be held responsible for loss of livestock, loss of crops, loss because of delays in harvesting or any expense or loss incurred for labor, supplies, substitute machinery, rental for any other reason, or for injuries either to the owner or to a third party, nor can we be called upon to be responsible for labor charges, other than originally agreed, incurred in the removal or replacement of components.
3. The customer will be responsible for and bear the costs of:
 - a) Normal maintenance such as greasing, maintenance of oil levels, minor adjustments, etc.
 - b) Transportation of any HARDI® product to and from where the warranty work is performed.
 - c) Dealer travel time to and from the machine or to deliver and return the machine from the service workshop for repair.
 - d) Dealer traveling costs.
4. This warranty will not apply to any product which is altered or modified without the express written permission of HARDI® and/or repaired by anyone other than an Authorized Service Dealer.
5. Warranty is dependent upon the strict observance by the purchaser of the following provisions:
 - a) That this warranty may not be assigned or transferred to anyone.
 - b) That the Warranty Registration Certificate has been correctly completed by dealer and purchaser with their names and addresses, dated, signed and returned to the appropriate address as given on the Warranty Registration Certificate.
 - c) That all safety instructions in the operator's manual shall be followed and all safety guards regularly inspected and replaced where necessary.
6. No warranty is given on second-hand products and none is to be implied.
7. HARDI® reserves the right to incorporate any change in design in its products without obligation to make such changes on units previously manufactured.
8. The judgement of HARDI® in all cases of claims under this warranty shall be final and conclusive and the purchaser agrees to accept its decisions on all questions as to defect and to the exchange of any part or parts.
9. No employee or representative is authorized to change this warranty in any way or grant any other warranty unless such change is made in writing and signed by an officer of HARDI® at its head office.

14 - Warranty

10. Any warranty work performed which will exceed \$400.00 MUST be approved IN ADVANCE by the Service Manager.
11. Claims under this policy must be filed with HARDI® within thirty (30) days of work performed or warranty shall be void.
12. Parts requested must be returned prepaid within thirty (30) days for warranty settlement.
13. Warranty claims must be COMPLETELY filled out properly or will be returned.

DISCLAIMER OF FURTHER WARRANTY

THERE ARE NO WARRANTIES, EXPRESSED OR IMPLIED, EXCEPT AS SET FORTH ABOVE. THERE ARE NO WARRANTIES WHICH EXTEND BEYOND THE DESCRIPTION OF THE PRODUCT CONTAINED HEREIN. IN NO EVENT SHALL THE COMPANY BE LIABLE FOR INDIRECT, SPECIAL OR CONSEQUENTIAL DAMAGES (SUCH AS LOSS OF ANTICIPATED PROFITS) IN CONNECTION WITH THE RETAIL PURCHASER'S USE OF THE PRODUCT.