



The Sprayer

Operator's Manual

COMMANDER 4500/5500/7000

Instruction book

67024103 - Version 1.10

US - 04.2016

COMMANDER 4500/5500/7000

Instruction book

67024103 - Version 1.10

US - 04.2016

1 - Welcome	
Welcome letter	7
2 - Safety notes	
Operator safety	9
Symbols	9
General info	9
Label explanation	10
Local poison information center	12
3 - Description	
General info	13
View	13
View	14
Identification plates	14
Roadworthiness	14
Sprayer use	15
Frame	15
Tanks and equipment	15
Liquid system	16
Pump	16
Valves and symbols	16
DynamicFluid4 pressure regulation	17
Clean water tank	19
Rinsing tank	19
Filters	19
EasyClean filter	19
CycloneFilter	20
TurboFiller	21
Diagram - Basic liquid system	22
Diagram - Liquid system with optional extras	23
Boom	24
Boom Operator's Manual	24
AutoTerrain (optional)	24
Hydraulic systems	25
Hydraulic blocks	25
Open center hydraulics	26
Equipment	27
SafeTrack	27
Driving technique for SafeTrack	27
Platform	28
Drawbars	28
Hydraulic support leg	29
Tank level indicator	30
External Cleaning Device (optional)	30
Nozzle pressure gauge	30
SafetyLocker	31
ChemLocker	31
4 - Sprayer setup	
General info	33
Unloading the sprayer from the truck	33
Pulling the sprayer at the tie down hooks	33
Before putting the sprayer into operation	33
Hydraulic support leg	34
Jack up the sprayer	34
Transmission shaft	35
Operator safety	35
P.T.O. installation	35

Table of Contents

Mechanical connections	36
Hose package support	36
SafeTrack potentiometer connection	36
Hydraulic systems	37
General info	37
Requirements - tractor	37
Open center hydraulics	38
Electrical connections	39
Installation of control unit brackets	39
Road safety kit	39
Power supply	40
Speed transducer for sprayer	40
Liquid system	41
CycloneFilter	41
Track gauge, axles and wheels	42
Altering the track width (adjustable axle)	42
Changing the wheel offset	42
Dual tire setup - 2014 (optional)	43
Dual tire setup - Pre 2014 (optional)	44
R.P.M. Transducer for pump	44
5 - Operation	
Boom	45
Safety info	45
Boom Operator's Manual	45
Maneuvering of the FORCE™ boom	46
Maneuvering of the boom - TERRA FORCE	47
Liquid system	48
Filling/washing location requirements	48
Filling of water	48
Filling through tank lid	48
Main Tank Quick Fill	49
Filling of rinsing tank	49
Filling of clean water tank	49
Safety precautions - crop protection chemicals	50
Filling chemicals through tank lid	50
Filling liquid chemicals by HARDI® TurboFiller	51
Filling powder chemicals by HARDI® TurboFiller	52
TurboFiller rinsing	53
Operating the control units while spraying	54
Before returning to refill the sprayer	55
Agitation before resuming a spray job	55
Parking the sprayer	55
Quick reference - Operation	55
Cleaning	56
General info	56
Quick reference - Cleaning	57
Cleaning and maintenance of filters	57
Use of rinsing tank and rinsing nozzles	57
A. Full internal rinsing	58
B. External cleaning	59
C. Rinsing spraying circuit without diluting main tank content	60
D: Full internal cleaning (Soak wash)	60
Use of detergents	61
Technical residue	61
Using the drain valve	62

6 - Maintenance	
Lubrication	63
General info	63
Recommended lubricants	63
Drawbar lubrication	63
Trailer/ParaLift lubrication & oiling plan	64
Service and maintenance intervals	65
10 hours service - Cyclone Filter	65
10 hours service - EasyClean filter	65
10 hours service -In-Line filter	66
10 hours service - Nozzle filters	66
10 hours service - Spraying circuit	66
50 hours service - Transmission shaft	66
50 hours service - Greasing the 464 pump	66
50 hours service - Wheel nuts	67
50 hours service - Tire pressure	67
100 hours service - Check/tighten steering	67
250 hours service - Readjustment of the boom	67
250 hours service - Hoses and tubes	67
250 hours service - Hydraulic circuit	68
250 hours service - Wheel bearings	68
1000 hours service - Transmission shaft	68
1000 hours service - Wheel bearings	69
Occasional maintenance	70
General info	70
Model 464 pump valves and diaphragms replacement	70
Model 463 pump valves and diaphragms replacement	71
Cone check/replacement for EFC distribution valve	72
Level indicator adjustment	72
Level indicator wire replacement	72
Drain valve seal replacement	73
Adjustment of 3-way valve	73
Safety valve activation	73
Readjustment boom - general info	74
Wear bushing replacement on boom lift	74
Change of bulbs	74
Wear bushing replacement on steering	74
Shield replacement on transmission shaft	74
Replacement of transmission shaft cross journals	74
Change of tire	75
Off-season storage	76
Off-season storage program	76
Preparing the sprayer for use after storage.	76
7 - Fault finding	
Operational problems	77
General info	77
Liquid system	78
Hydraulic system - Z model	79
Mechanical problems	80
Emergency operation - Liquid system	80
Emergency operation - EasyClean filter	80

Table of Contents

8 - Technical specifications

Dimensions	81
General info	81
Overall dimensions	81
Weight	81
Weight (cont.)	82
Wheel and axle dimensions	82
Specifications	83
Diaphragm pumps	83
Technical residue	83
Filters and nozzles	83
Power consumption	84
Tire pressure	84
Materials and recycling	85
Disposal of the sprayer	85
Electrical connections	86
Rear lights	86
Electrical specifications for boom and work light	86
EFC	87
Charts	88
Sprayer hydraulics	88

9 - Warranty

Warranty policy and conditions	89
---	-----------

Index

Index	91
--------------------	-----------

Welcome letter



Dear New HARDI® Owner,

Thank you for purchasing your new HARDI® product and welcome to the ever-increasing family of proud HARDI® owners.

HARDI® is the leading sprayer company in offering growers strong, reliable products made for the widest range of applications worldwide. Quality, reliability, and resale value make the HARDI® product line the preferred product line of customers both in North America as well as worldwide. Our guiding principle is to provide the highest level of customer satisfaction and long term value in the marketplace today. We have developed a very high level of customer loyalty in the marketplace which we are very proud of and strive every day to maintain and to continue to grow.

HARDI® is your specialist in spraying and we spend all of our time and keep all of our focus on spraying. We do not share our resources between other types of products or compromise on anything in providing the best quality sprayers to the market today. We can provide the latest in technology with our products if desired, or allow them to operate with the technology that you already use on other products in most cases. You get to decide that, and what best suits your needs. We feel that you, our customer, are the best suited to answer that question for your operation. Either way, you decide, and we will try and help make it happen for you.

Our broad spectrum of product offerings, from the ruggedly simple models we build to our highly sophisticated models, the built-in HARDI® strength and reliability ensures a low cost of ownership. HARDI® sprayers are all based on a functional design concept of being as simple to operate as possible and to meet our customers' requirements for all their application needs.

Please take the time to thoroughly read the Operator's Manual before using your equipment. You will find many helpful hints as well as important safety and operation information.

Some of the features on your HARDI® sprayer were suggested by growers. There is no substitute for "on farm" experience and we invite your comments and suggestions. If any portion of this instruction book remains unclear after reading it, contact your HARDI® dealer or service personnel for further explanation before using the equipment.

For Product, Service or Warranty Information please contact your local HARDI® dealer.

- Please use the HARDI® Customer Service number: 1-866-770-7063

- Or send your email to CUSTSERV@hardi-us.com

HARDI® NORTH AMERICA INC.

Visit us online at: www.hardi-us.com

1500 West 76th St.
Davenport, Iowa 52806
Phone: (563) 386-1730
Fax: (563) 386-1280

Sincerely,

A handwritten signature in black ink, appearing to read "Wayne Buchberger". The signature is fluid and cursive, with a long horizontal stroke extending to the right.

Wayne Buchberger

President

Operator safety

Symbols

These symbols are used throughout the book to designate where the reader needs to pay extra attention.



This symbol means DANGER. Be very alert as your safety is involved!



This symbol means WARNING. Be alert as your safety can be involved!



This symbol means ATTENTION. This guides you to better, easier and safer operation of your sprayer!



This symbol means NOTE.

General info

Note the following recommended precautions and safe operating practices before using the sprayer.



Read and understand this instruction book before using the equipment. It is equally important that other operators of this equipment read and understand this book.



If any portion of this instruction book remains unclear after reading it, contact your HARDI® dealer for further explanation before using the equipment.



Local law may demand that the operator is certified to use spray equipment. Adhere to the law.



The driver's seat is the intended working place during operation.



Wear protective clothing. Clothing may differ depending on the chemical being sprayed. Adhere to local law.



Wash and change clothes after spraying. Wash tools if they have become contaminated.



Do not eat, drink or smoke while spraying or working with contaminated equipment. In case of poisoning, immediately seek medical advice. Remember to identify chemicals used.



No persons are allowed in the operation area of the sprayer. Be careful not to hit people or surroundings when maneuvering the sprayer, especially while backing up.



Slow down when driving in uneven terrain as the machine might be in risk of turning over.



Keep children away from the equipment!



Do not attempt to enter the tank.



Do not go under any part of the sprayer unless it is secured. The boom is secure when placed in the transport brackets.



Pressure test with clean water prior to filling with chemicals. Never disconnect the hoses if the machine is in operation.







DANGER! Do not exceed the P.T.O. max. recommended r.p.m.



Rinse and wash equipment after use and before servicing.

2 - Safety notes











-  Never service or repair the equipment while it is operating. Always replace all safety devices or shields immediately after servicing.
-  Disconnect electrical power before servicing and depressurize equipment after use and before servicing.
-  If an arc welder is used on the equipment or anything connected to the equipment, disconnect power leads before welding. Remove all inflammable or explosive material from the area.
-  The External Cleaning Device should not be used if essential parts of the equipment have been damaged, including safety devices, high pressure hoses, etc.

Label explanation

The labels designate potential dangerous places on the machine. Anybody working with or being in close range of the sprayer must respect these labels!

The labels should always be clean and readable! Worn or damaged labels must be replaced with new ones. Contact your local dealer for new labels.

 Note that not all labels shown here will apply to your sprayer.

- | | | | |
|---|--|---|---|
| 
978437 | Chemical handling!
Carefully read the information about chemical preparation before handling the machine. Observe instructions and safety rules when operating. | 
978443 | Service!
Carefully read operator's instruction book before handling the machine. Observe instructions and safety rules when operating. |
| 
978436 | Service!
Shut off the engine and remove ignition key before performing maintenance or repair. | 
978440 | Service!
Tighten to torque according to instruction book. |
| 
97802100 | Risk of death!
Do not attempt to enter tank. | 
978447 | Risk of burn!
Stay clear of hot surfaces. |
| 
978444 | Risk of injury!
Do not open or remove safety shields while engine is running. | 
978586 | Risk of injury!
Flying objects, keep safe distance from machine as long as the engine is running. |
| 
978448 | Risk of injury!
Keep sufficient distance away from electrical power lines. | 
978435 | Risk of injury!
Keep hands away. |

2 - Safety notes



978441 Risk of squeeze!
Stay clear of raised, unsecured loads.



978445 Risk of squeeze!
Never reach into the crushing danger area as long as parts are moving.



978434 Risk of squeeze!
Keep hands away when parts are moving.



978442 Risk of falling off!
Do not ride on platform or ladder.



978446 Risk of sprayer tipping over!
Be aware when disconnecting the sprayer.



978438 Gripping area!
Manual handling of boom, etc.



97802200 Not for drinking!
This water must never be used for drinking water.



97802300 Not for drinking!
This water must never be used for drinking water.



97818100 Tank under pressure!
Beware when removing lid.



EasyClean filter service!
Open and clean filter monthly.

97827000



97829000 Lifting point!



978439 Lifting point!

2 - Safety notes

Local poison information center



If you live anywhere in the United States, the following toll free number will connect you to your Local Poison Information Center.

PHONE NO. 1 - 800 - 222 - 1222



If you live outside the United States, find the number for the poison control center in your phone book and write it in the space below:

PHONE NO. _____ - _____ - _____



Keep a list, in the space provided below, of all the chemicals that you have in use.

1. _____

2. _____

3. _____

4. _____

5. _____

6. _____

7. _____

8. _____

9. _____

10. _____

General info

View

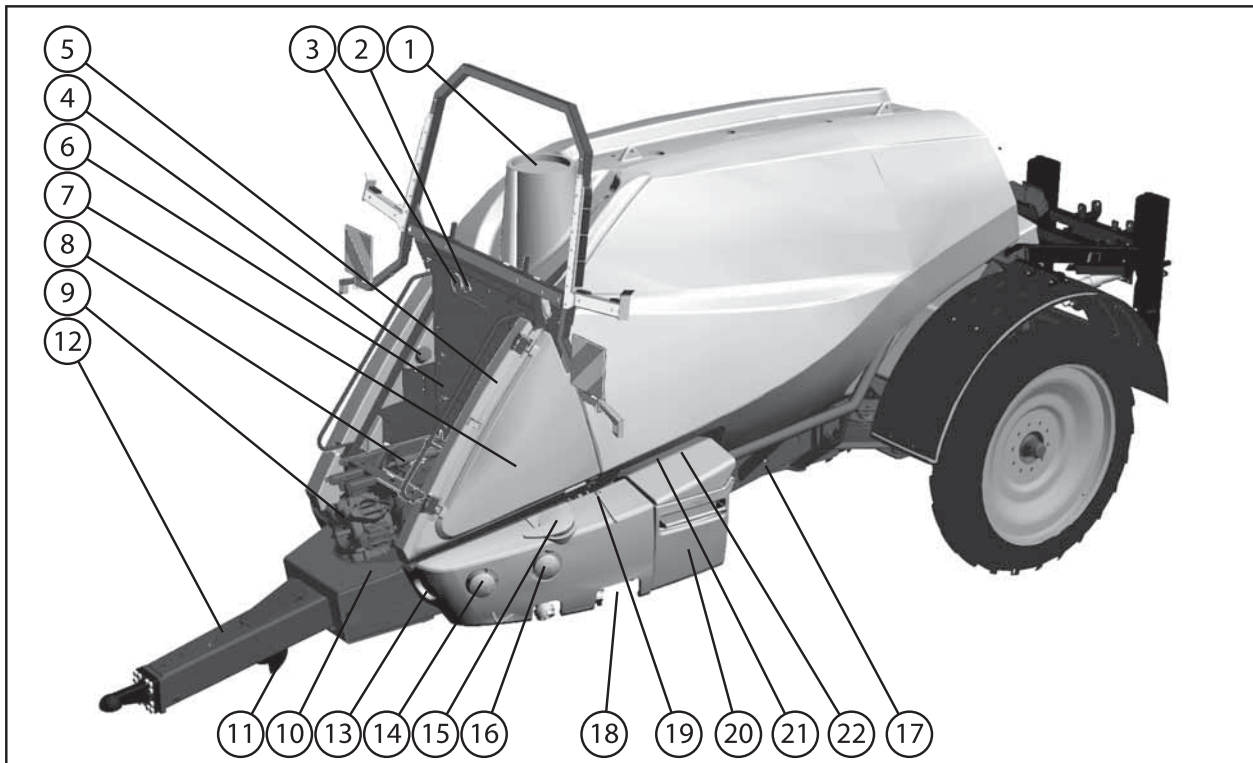

- | | |
|---------------------------------|---|
| 1. Main tank lid | 12. Drawbar hitch |
| 2. EasyClean clogging indicator | 13. Agitation valve |
| 3. Spray pressure gauge | 14. Suction SmartValve |
| 4. Clean water tank lid | 15. EasyClean filter |
| 5. Main tank level indicator | 16. Pressure SmartValve |
| 6. Rinsing tank level indicator | 17. Main tank Quick Fill coupler |
| 7. SafetyLocker | 18. Rinsing tank Quick Fill coupler |
| 8. Platform | 19. Clean water valve |
| 9. Pump | 20. TurboFiller |
| 10. Ladder | 21. Lever for chemical container cleaning |
| 11. Support leg | 22. TurboFiller Vortex nozzle valve |

3 - Description

View

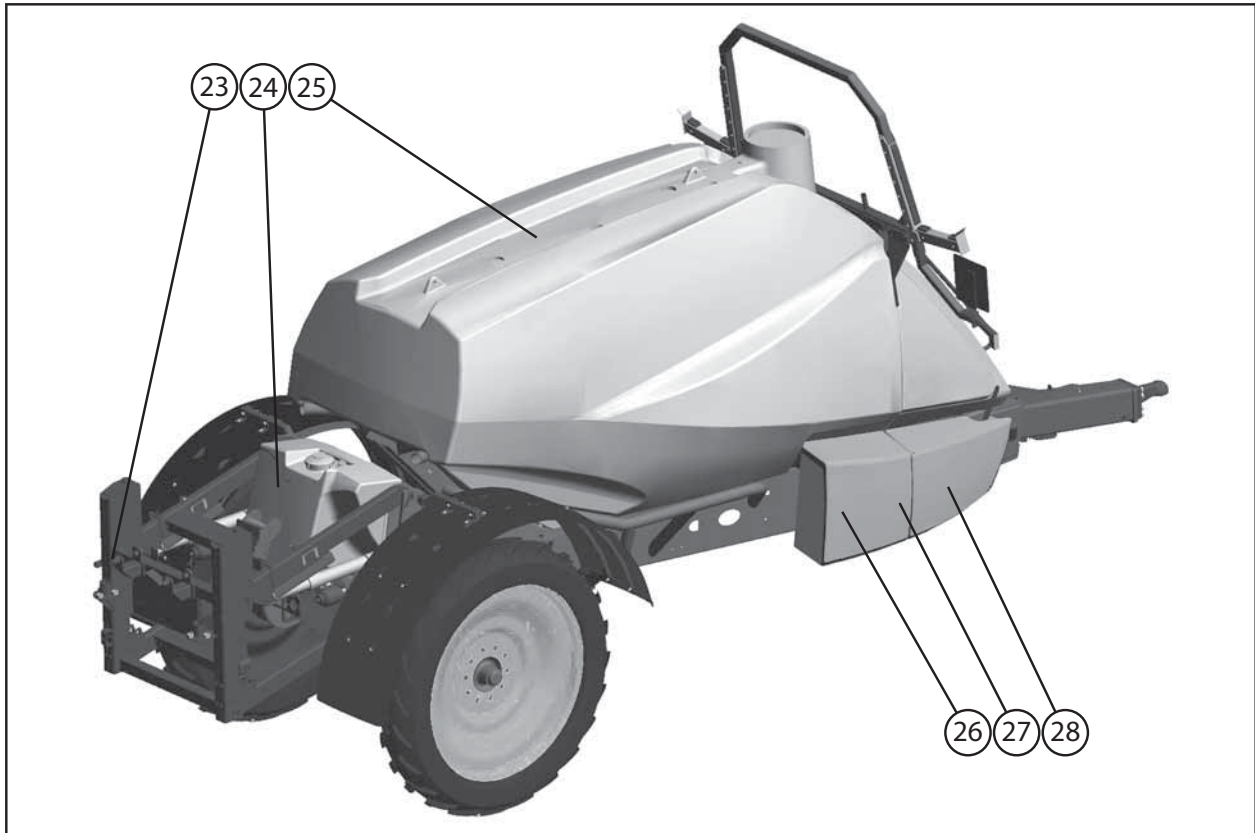

- 23. Distribution valves (not illustrated)
- 24. Rinsing tank
- 25. Main tank

- 26. ChemLocker (with optional FoamMarker tank)
- 27. Spray wand for External Cleaning Device
- 28. CycloneFilter

Identification plates

An identification plate fitted on the frame indicates producer name, model and serial number.



Frame, boom center frame and other main steel components have identification plates indicating type and part number. (not illustrated)

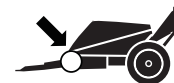

Roadworthiness

When driving on public roads and other areas where the highway code applies, or areas with special rules and regulations for marking and lights on implements, you should observe these and equip implements accordingly.



ATTENTION! Max. driving speed for models without brakes and for models equipped with brakes is different. Be aware that these speeds may differ due to local law. Contact local authorities for information of max. driving speeds!

Sprayer use

The HARDI® sprayer is for the application of crop protection chemicals and liquid fertilizers. The equipment must only be used for this purpose. It is not allowed to use the sprayer for any other purposes. If no local law demands that the operator must be certified to use spray equipment, it is strongly recommended to be trained in correct plant protection and in safe handling of plant protection chemicals to avoid unnecessary risk for persons and the environment when doing your spray job.

Frame

Very strong and compact frame which also has a strong chemical and weather resistant electrostatic lacquer coat. Screws, nuts, etc. have been treated to be resistant to corrosion.

Tanks and equipment

The main tank made of impact-proof, UV-resistant and chemical resistant polyethylene, has a purposeful design with no sharp corners for easy cleaning. The filling hole is placed so it can be accessed from the platform. This ensures an easy access for the filling of sprays, cleaning of the tank, etc. The sprayer is also equipped with a rinsing tank and a clean water tank. A large, easy to read tank contents indicator is placed beside the platform and is visible from the tractor cabin.

Nominal contents 1200 gal (4500 liters), 1600 gal (5500 liters) or 2000 gal (7000 liters).

3 - Description

Liquid system

Pump

Diaphragm pump with 6 diaphragms, model 464. Standard = 540 r.p.m. (6 splines shaft). Optional = 1000 r.p.m. (21 splines shaft). The design of the diaphragm pump is simple, with easily accessible diaphragms and valves which ensures liquid does not contact the vital parts of the pump.

FlexCapacity pump

Some sprayers facilitates a dual pump setup with an extra hydraulically driven pump of same type as the main pump, placed on sprayers right side.

The FlexCapacity pump is turned ON/OFF with a separate hydraulic lever in the tractor cabin.

Valves and symbols

The possible functions of valves are distinguished by colored identification on the function labels. The modular valve system facilitates the addition of optional extras on both pressure side and suction side. A function is activated by turning the handle to the desired function.



ATTENTION! Only the functions used should be open - always close remaining valves.



ATTENTION! If a valve is too tight to operate - or too loose (= liquid leakage) - the valve needs to be serviced. Please see "Adjustment of 3-way valve" on page 73 for further information.

Pressure SmartValve (Green symbols)

This valve is to select which function the pressurized liquid from the pump will be routed to.

The active function is indicated by the indicator. The handle is turned so the indicator points to the label for required function. If handle is turned to a position without label (unused function) then the valve is closed.

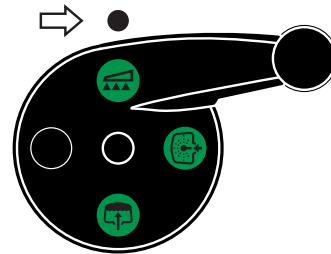

Spraying



Internal tank rinsing



TurboFiller

Suction SmartValve (Blue symbols)

This valve is to select suction from main tank or from the rinsing tank.

The handle is turned so the label for required function is directed to the indicator. If handle is turned to vertical position (indicator not pointing at a label) then the valve is closed.

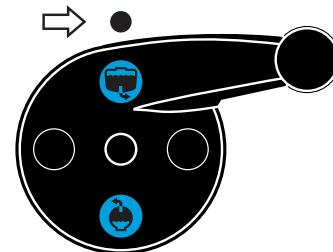

Main tank



Rinsing tank

DynamicFluid4 pressure regulation

DynamicFluid4 regulation is a continuous process that continues even if the nozzles are closed. Two ceramic discs regulate the pressure and ensures quick reaction and zero leakages. Sprayer speed, P.T.O. RPM and number of sections activated are parameters used, and the benefit is more precise application rates from the second the sprayer begins spraying.

The DynamicFluid4 uses feed forward technology based on 5 sensors that feed the JobCom computer with data necessary for optimal regulation. It auto-primes at start-up, starts and moves the valve towards the final position immediately after the operator makes changes. E.g. when section valves are opened or closed, the regulation valve is started the same time the section valve motors are started. This avoids overpressure situations e.g. after running empty and refill of main tank.

The 5 sensors are also back-up for each other and ensures the system can continue regulation even if one or more sensor signals fail. Sensors used are:









- Sprayer speed sensor
- Flow sensor
- Pressure sensor
- Pump r.p.m. sensor
- Regulation valve opening angle sensor

The DynamicFluid4 pressure regulation features are:

- Very fast and accurate regulation when all sensors are ok, setup in menus are correct and pump, filters and valves are in good condition.
- Quick reacting valve when sections are turned ON/OFF and at speed changes.
- Optimized AutoSectionControl feature that predicts boom sections will open and nozzle pressure.
- Optimized for different P.T.O. systems.
- Nozzle surveillance. No setup or tuning required for nozzle change.
- Warning in display if failures occur on boom plumbing, such as severe clogging of line or nozzle filters or large leakages on hoses and fittings.
- All functions work, although with degraded performance (Limp home modes), if:
 - Faults occur in fluid system, e.g. pump defects, clogged filters, leaking valves.
 - Sensor failure appear on pressure sensor, flow sensor or RPM sensor.
 - There is wrong setup of sprayer data in menus.
- Emergency mode if angle sensor or speed sensor fails.

Screen icons

The sprayer driver selects one of three modes Auto, Manual or Increment steps. The sprayer computer detects one of three regulation modes Drop, Question mark or calibration jug. This makes 9 modes in total.

Auto	Manual	Increment steps	
When Automatic Volume Rate button is pressed on the SetBox.	When one of the Manual pressure control buttons is pressed on the SetBox.	When the Volume Rate is changed in steps with %-up or %-down buttons on the Terminal.	
			Calibration jug There is flow to section valves. Nozzle size (G/min at 45 psi) has been calculated.
			Drop There is no flow to section valves. The pump is not started or the pressure SmartValve is set to other function than spraying.
			Question mark There is flow to section valves but pressure and flow has not yet been stable, therefore the nozzle size (G/min at 45 psi) has not been calculated. The system uses the previously stored nozzle size.

3 - Description

Regulation valve function diagram



ATTENTION! Auto mode icons shown, but could be Manual or Increment steps icons, depending on driver selection.



Clean water tank

The water in this tank is for hand washing, cleaning of clogged nozzles etc. Only fill this tank with clean water from the well.

Capacity: approximately 5 gal (20 liters).



WARNING! Although the clean water tank is only filled with clean water, this water must NOT be used for drinking.

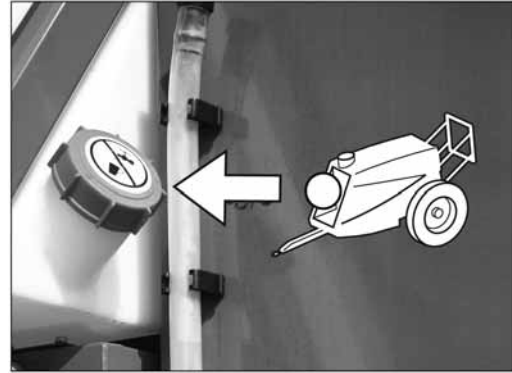

Rinsing tank

A rinsing tank is mounted to the rear of the sprayer. The tank is made of impact-proof and chemical resistant polyethylene. Filling is done via the 2" Quick Coupler and valve placed in the working area. The rinsing tank level indicator is placed at the platform.

Nominal content: approximately 120 gal (450 liters).

Filters

An EasyClean suction filter is fitted in the working zone.

A Cyclone pressure filter is fitted to the sprayers right side just in front of the optional hose reel, hidden behind the right front cover. It has a built-in self-cleaning function.

In-line pressure filters can be fitted at each boom section as standard.

Nozzle filters are fitted at each nozzle (optional).

All filters should always be in use and their function checked regularly. Pay attention to the correct combination of filter and mesh size (see "Spray Technique" book).

EasyClean filter

To ensure proper function of filter and its built-in valve the filter must be opened at least 1 time per month. A label on the lid also designates this.

- To open filter then turn it counterclockwise and pull it up, like shown on picture.
- Pull out the two locks (A) to remove filter element from the lid.

Beside the spray pressure gauge on the platform a EasyClean clogging indicator is located:

Clogging indicator color	Filter status
Green indicator.	No cleaning necessary.
Yellow indicator.	It is possible to finish an ongoing spraying job and then clean filter afterwards.
Red indicator.	Clean EasyClean filter immediately as filter is clogged.

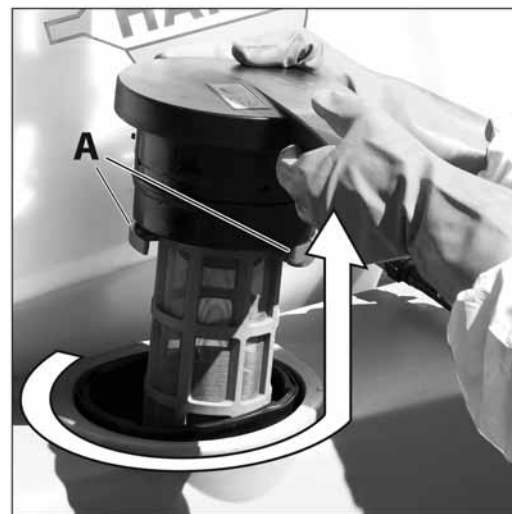

3 - Description

CycloneFilter

With the CycloneFilter any impurities in the spray liquid will by-pass the filter and be re-circulated back to the tank via the return flow.

Function diagram

1. Filter lid
2. From pump
3. To boom
4. Return to tank
5. Return valve

Valve (5) has three positions marked with small dots on the lever:

- A. This position marked with 1 dot: There is no return flow. Position is used when rinsing the boom if there is spray liquid in the main tank. Also used when high spraying volume is required.
- B. This position marked with 2 dots: Normal spraying position. With return flow to prevent filter is going to be clogged when spraying. This position is used when rinsing the boom if the main tank is empty.
- C. This position marked with 3 dots: Flushing position which is used if filter is clogged. Lift and hold the lever to use this position which largely increases return flow and flushes the filter. The pressure SmartValve must be set to "Spraying".



ATTENTION! Use of position C is no guarantee for a clean filter. Always regularly do a visual inspection and cleaning of the filter. If necessary see "10 hours service - Cyclone Filter" on page 65.



DANGER! Never open the Cyclone filter unless the pressure SmartValve is turned to "Main tank". Otherwise, spraying liquid may hit you when opening the filter, and drain from the main tank!

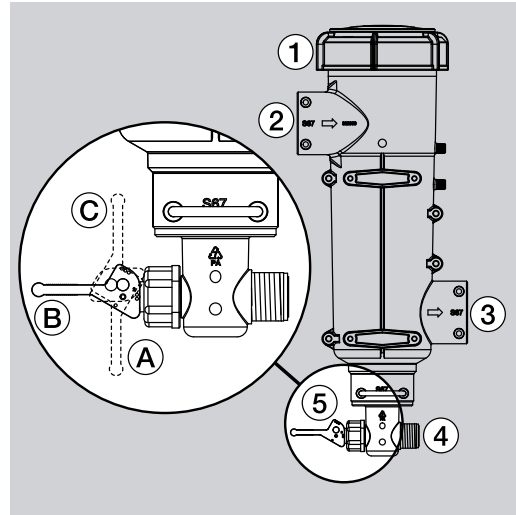

TurboFiller

Before use

- Push the handle (arrow) to unlock.
- Grab the handle to pull TurboFiller down until it clicks into locked down-position.

After use

- Push the handle (arrow) to unlock.
- Grab the handle to push TurboFiller back in storing position until it locks.



WARNING! Before releasing the lock (arrow) always keep a hand on the grip to avoid abrupt movement of the TurboFiller!

The TurboFiller valves and Chemical Container Rinsing lever are placed on the backside (arrow).



TurboFiller suction valve

The valve is used simultaneously with the TurboFiller. The valve has 2 settings: Push the valve lever down to get a quick suction out of the hopper. Lift the lever to lock it in the open position for continuous suction from the hopper into the main tank. Open the valve when chemicals are going to be filled into the TurboFiller



Suction from TurboFiller

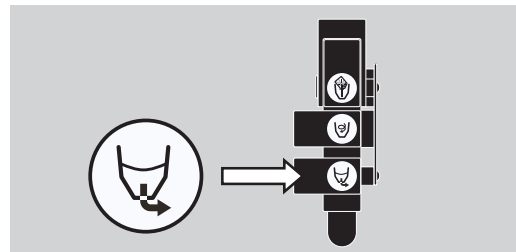

TurboDeflector valve

This TurboDeflector valve activates the Vortex flushing of the TurboFiller. The valve has 2 settings: Push the valve lever down to get a quick flush of the hopper. Lift the lever to lock it in open position for continuous liquid rotation in the hopper.



Start TurboDeflector

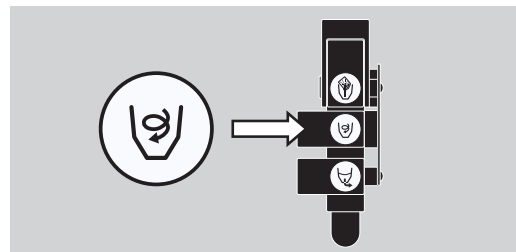

Chemical Container Rinsing lever

The rinsing lever is used for two purposes:

When the TurboFiller lid is open: For rinsing empty containers. Place the container over the rotating flushing nozzle in the middle of the TurboFiller to rinse the inside of the container.

When the TurboFiller lid is closed: Use the Chemical Container Rinsing lever to rinse the hopper after the filling of chemicals is completed.



Chemical Container Rinsing

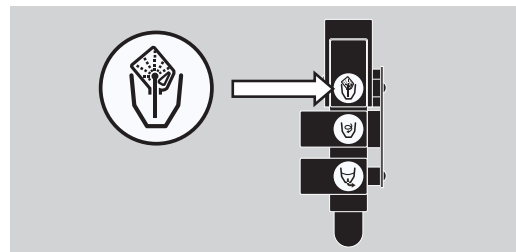

DANGER! Do not press the lever unless the multi-hole nozzle is covered by a container or the TurboFiller lid is closed to avoid spray liquid hitting the operator.

3 - Description

Diagram - Basic liquid system

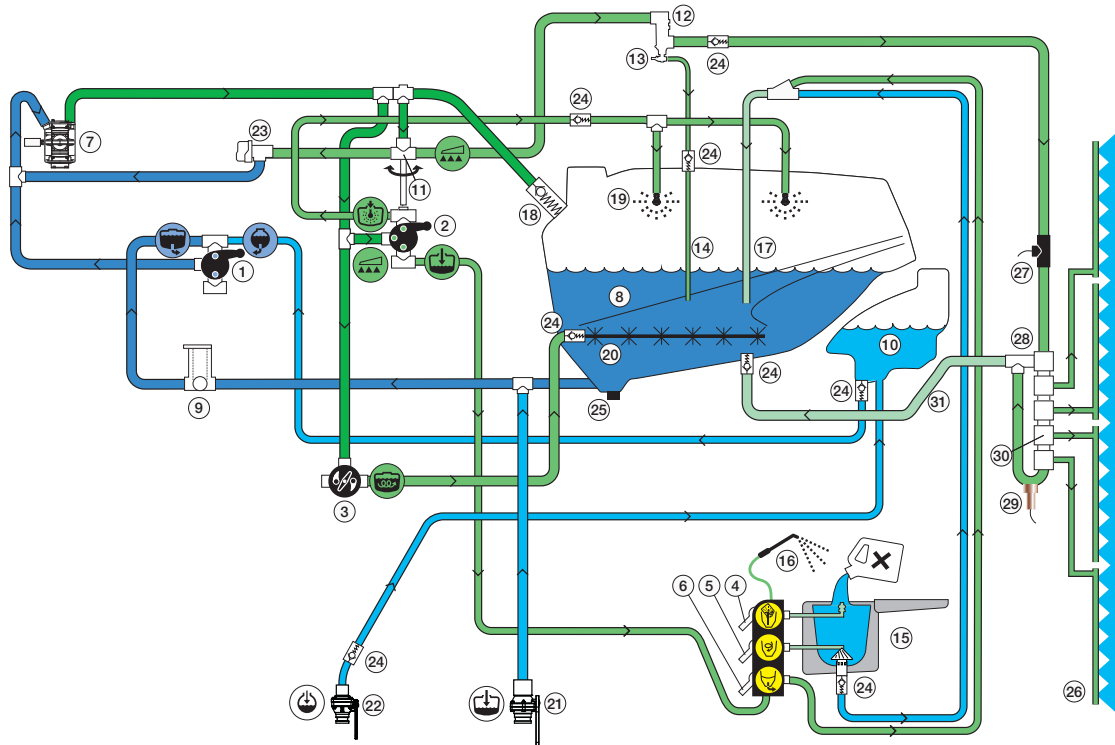

- | | |
|--------------------------------------|---|
| 1. Suction SmartValve | 17. TurboFiller to tank tube |
| 2. Pressure SmartValve | 18. Safety valve |
| 3. Agitation valve | 19. Internal tank rinsing nozzles |
| 4. Chemical container cleaning valve | 20. Agitation tube |
| 5. TurboDeflector ON/OFF valve | 21. Main Tank Quick Fill coupler |
| 6. TurboFiller suction ON/OFF valve | 22. Rinse Tank Quick Fill coupler |
| 7. Pump | 23. DynamicFluid4 pressure regulation valve |
| 8. Main tank | 24. One-way valve |
| 9. EasyClean filter | 25. Drain valve |
| 10. RinseTank | 26. Sprayer boom |
| 11. Spray valve | 27. Flow meter |
| 12. CycloneFilter | 28. Bypass valve |
| 13. Boost valve | 29. Boom pressure sensor |
| 14. Return line for boost function | 30. Distribution valves |
| 15. TurboFiller | 31. Return from distribution valves |
| 16. Wand for cleaning TurboFiller | |

Diagram - Liquid system with optional extras

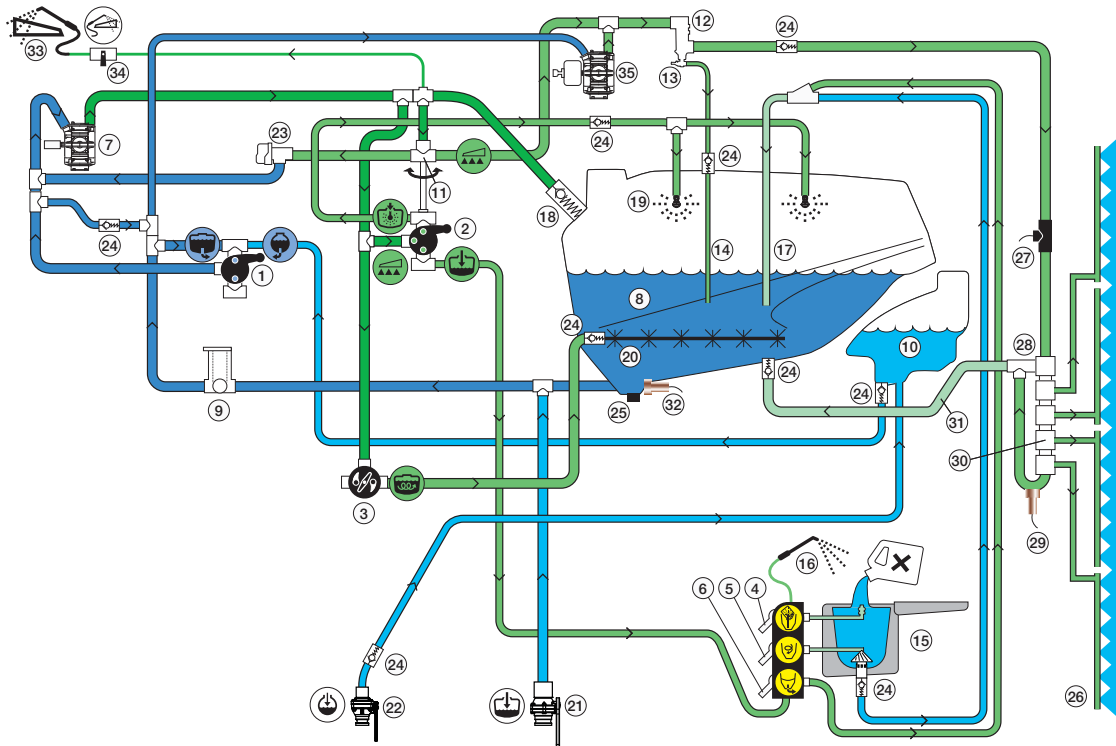

- | | |
|--------------------------------------|---|
| 1. Suction SmartValve | 19. Internal tank rinsing nozzles |
| 2. Pressure SmartValve | 20. Agitation tube |
| 3. Agitation valve | 21. Main Tank Quick Fill coupler |
| 4. Chemical container cleaning valve | 22. Rinse Tank Quick Fill coupler |
| 5. TurboDeflector ON/OFF valve | 23. DynamicFluid4 pressure regulation valve |
| 6. TurboFiller suction ON/OFF valve | 24. One-way valve |
| 7. Pump | 25. Drain valve |
| 8. Main tank | 26. Sprayer boom |
| 9. EasyClean filter | 27. Flow meter |
| 10. RinseTank | 28. Bypass valve |
| 11. Spray valve | 29. Boom pressure sensor |
| 12. CycloneFilter | 30. Distribution valves |
| 13. Boost valve | 31. Return from distribution valves |
| 14. Return line for boost function | |
| 15. TurboFiller | Options |
| 16. Wand for cleaning TurboFiller | 32. Main tank gauge sensor |
| 17. TurboFiller to tank tube | 33. External cleaning device |
| 18. Safety valve | 34. External cleaning ON/OFF valve |
| | 35. FlexCapacity pump |

3 - Description

Boom

Boom Operator's Manual

A separate "Boom Operator's Manual" is supplied with your sprayer and contains detailed information on boom safety, set-up, operation and maintenance.



DANGER! Important information on Safety, Operation and Maintenance specific to your boom configuration is detailed in the "Boom Operator's Manual" supplied with your sprayer. It must be read and fully understood by anyone intending to operate this equipment. Failure to do so could result in serious personal injury or death.

AutoTerrain (optional)

AutoTerrain is a computer controlled pre-emptive boom stability and auto height control system which maintains the correct relationship and height of the boom to the different field conditions. AutoTerrain highly tuned computer controlled proportional electro-hydraulics and ultrasonic sensors help spray more safely, reducing potential ground strikes and prevents incorrect spray height.



WARNING!

- Stability control roll sensor and indicator must be correctly aligned to prevent uncontrolled and continuous boom oscillation.
- The pendulum center stability control linkage points must be regularly lubricated to protect swivel balls from moisture penetration and prevent swivel ball seizure.
- The boom should never be used to spray with the pendulum lock engaged.



ATTENTION!

- For optimum AutoTerrain performance the stability & height control sensors must be checked and cleaned regularly.
- Dusty, damp or missing sensors pads will not read accurately and AutoTerrain will be compromised. Foam pads must be washed and dried daily. The boom should not be used if foam pads are missing from the sensors.
- Regarding AutoTerrain, please refer to specific book for information about Operation, Calibration and Maintenance.

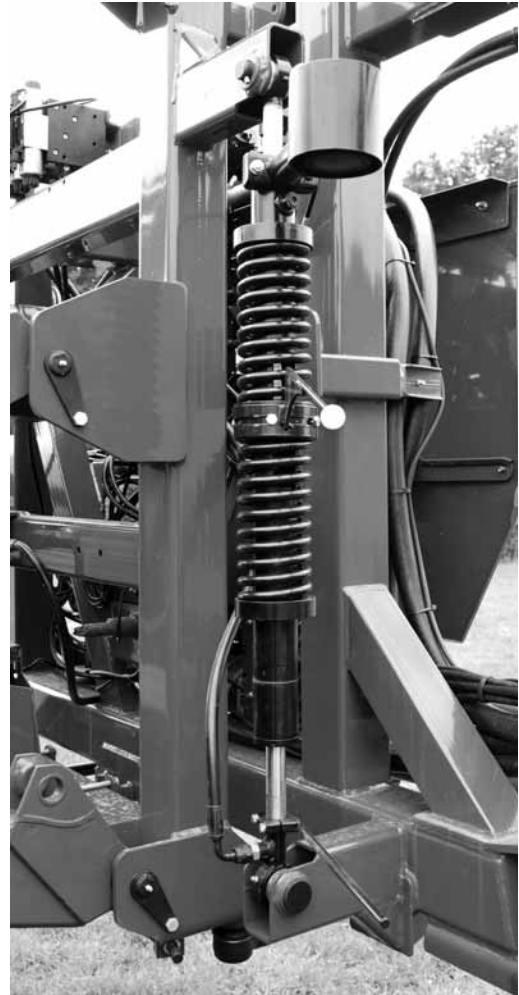

Hydraulic systems

Hydraulic blocks

Hydraulic blocks fitted to the sprayer are:

Boom

The main boom hydraulic block that manages hydraulic pressure for the boom controls.

The throttle valve (A) can adjust the folding speed of the boom.
Adjusting inwards = slower boom.



ParaLift

This hydraulic block manages hydraulic pressure for the ParaLift.



3 - Description

Open center hydraulics

The open center hydraulics block is necessary if the tractor uses open center hydraulics and/or load sensing. For adjustment see "Open center hydraulics" on page 38.

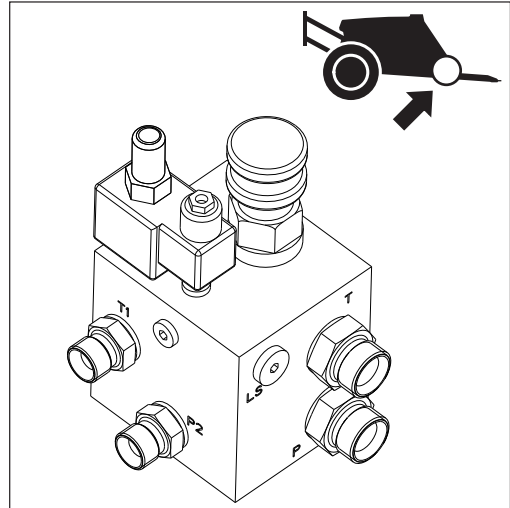

SafeTrack

On sprayers with SafeTrack steering this hydraulic block manages hydraulic pressure for the steering functions.

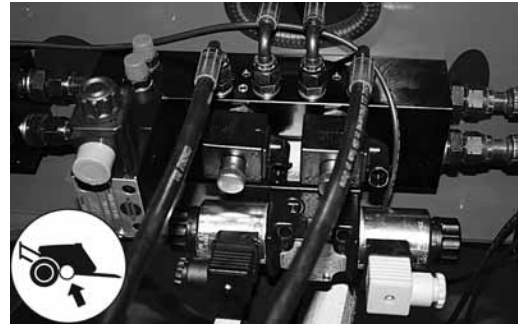

AutoHeight UCS

On sprayers with AutoHeight this hydraulic block manages hydraulic pressure for the automatic boom height control functions.

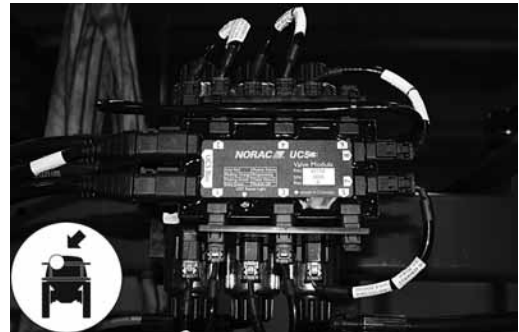

Equipment

SafeTrack

The SafeTrack will make the sprayer automatically follow the tractor when turning on headland. The SafeTrack can easily be operated with the hydraulic control unit. SafeTrack has an integrated safety feature which prevents over-steering when the driving speed is too high for the given turning radius. If a TankGauge is fitted, the tank filling level is also taken into account.

The SafeTrack is limited to speeds below 19 mph (30 km/h) Driving in "Auto" with SafeTrack will trigger an overspeed alarm and sprayer will automatically align.



WARNING! During road transport the drawbar must be aligned in center position. Refer to the HC 6500/9500 controller instruction book for specific instructions.



NOTE! IntelliTrack requires the HC 6500/9500 or ISOBUS controller. More information about the controller can be found in the separate instruction book.

Driving technique for SafeTrack

A trailer with SafeTrack behaves differently than a normal trailer. In tracking position the vehicle center of gravity is displaced more outward compared to the vehicle center line of a normal trailer. Compared to a conventional trailer a steered trailer has decreased stability when turning, especially when turning on hillsides (B).

To avoid overbalancing, pay attention to these guidelines:

- Avoid sudden, tight turns.
- Slow down before entering a curve or turning, and drive with a constant, low speed during the turn.
- Never slow down too fast, never brake heavily and never stop suddenly in a curve, or when turning on a hillside, when the sprayer is articulated.
- Be careful when turning on uneven ground.
- Set the track width (A) as wide as possible.
- The proper function of the hydraulic system is essential to obtain good stability.
- A filled rinsing tank will increase stability.

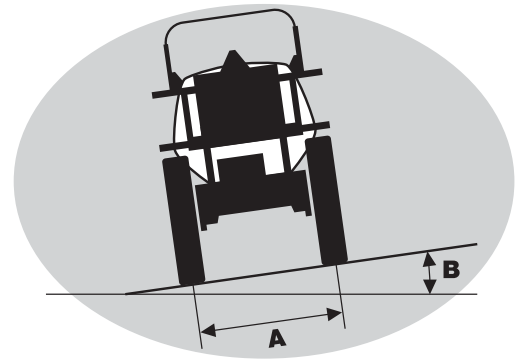

DANGER! No persons are allowed in the operations area of the sprayer when steering is unlocked!



WARNING! Never articulate steering when boom is in transport position.

3 - Description

Platform

To get access to the platform pull and tilt the ladder down. In retracted position the ladder is secured by a rubber stop. From the platform following can be accessed:

- Main Tank lid.
- Clean water tank lid, integrated to the side of the platform.
- Lift and remove the platform floor (A) to get access to hydraulic and MANIFOLD components underneath the platform floor.
- Electronics and optional fast filler are situated behind the cover (B).
- Pressure gauge, EasyClean filter clogging indicator and level indicator for the rinsing tank are visible here.



ATTENTION! Always tilt up the ladder before driving.

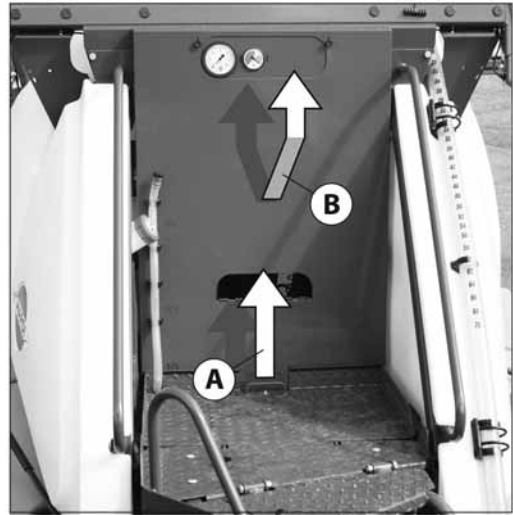

Drawbars

Rigid drawbar

The COMMANDER 4500 is equipped with a rigid drawbar. The swivel hitch (Ø50 mm) is welded to the drawbar.

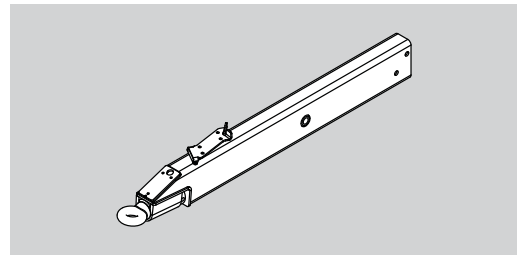

Suspended drawbar

For COMMANDER 5500 and 7000 models the drawbar is fully suspended.

The full up and down load from the sprayer to the tractor are transferred through rubber dampers built into the chassis.

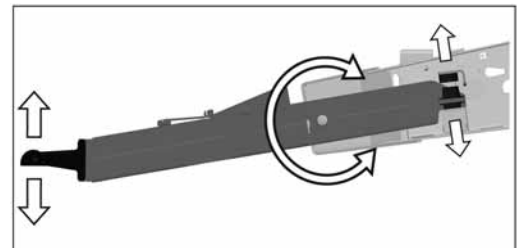

Hydraulic support leg

The hydraulic support legs are driven by a separate hydraulic outlet on the tractor. See "Hydraulic support leg" on page 34 for use of the support leg.



DANGER! Do never leave the sprayer standing unlocked on the support leg. Always double check that the lever is in locked position.

Standard for CM 5500/7000

The support leg is stored in its retracted position when the sprayer is attached to the tractor.

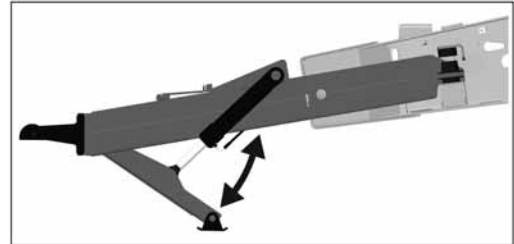

3 - Description

Tank level indicator

The actual tank level in the main tank can be observed on the tank level indicator. The scale is displayed in US gal. or Liters (certain countries).



ATTENTION! The wire guide wheels should be directed so they follow the direction of the wire.

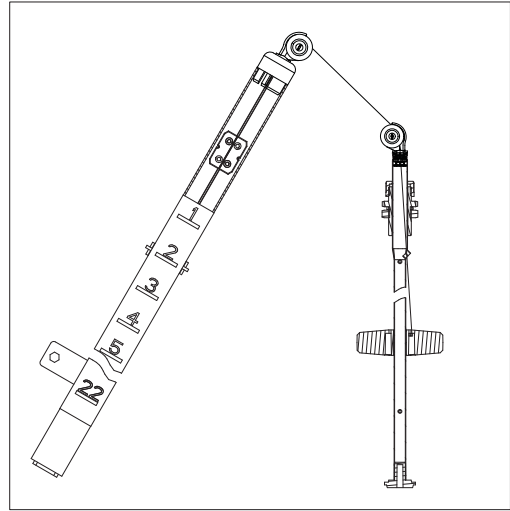

External Cleaning Device (optional)

This equipment comprises a hose reel and spray gun (C) used to clean the complete sprayer externally in the field with clean water. The External Cleaning Device gun (C) is located on the sprayers right side behind the ChemLocker cover.

Ball valve:

- Open
- Closed



NOTE! Do not let go of the hose. Gently restrict the roll-in of the hose.



WARNING! The Cleaning Device produces a high pressure water jet. Incorrect use may result in personal injuries!



DANGER! Always wear protective clothing. It is recommended to wear goggles and boots during the work. Protect yourself or anyone near the cleaning area against particles bouncing up while cleaning.



DANGER! For the safety of yourself and others, the following rules should always be observed:
Never point the water jet at people, animals, electrical installations or other sensitive objects.
Never try to clean clothing or footwear which you or other people wear.

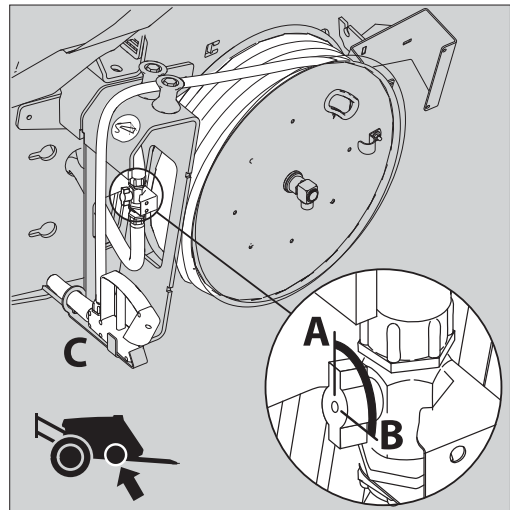

Nozzle pressure gauge

The remote pressure gauge is integrated at the top of the platform. This gauge measures the working pressure in the boom tubes as close to the nozzles as possible.

The outputs stated in the nozzle charts are always based on the pressure measured at the nozzle. Both when calibrating and spraying, the pressure must be adjusted according to the readings of this pressure gauge.



SafetyLocker

The locker is integrated to the front just above the SmartValves. It is for the purpose of storing non-contaminated protective gear, soap for hand washing etc.

The locker is split in two compartments for the separation of clean clothes from gloves with risk of contamination and includes a strap (A) to secure a soap dispenser.



WARNING! Although this locker is meant for storing nontoxic items, it must never be used for storing food, beverage or other things meant for consumption.



ChemLocker

A ChemLocker for storage of chemical containers etc. is mounted on the right side of the sprayer.

If an optional FoamMarker is installed, then a FoamMarker tank may be located inside the ChemLocker (if equipped).



ATTENTION! Max. load 220 lbs. (100 Kgs.).

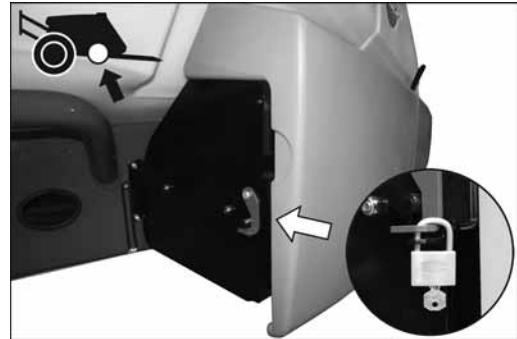

The ChemLocker has a removable cap for draining.



3 - Description

General info

Unloading the sprayer from the truck

For the unloading of the sprayer, you need a crane. When unloading with a crane please observe the lifting points as shown in the picture, and make sure that the straps or belts used for lifting are strong enough.



ATTENTION! Only lift the sprayer when the tanks are empty!

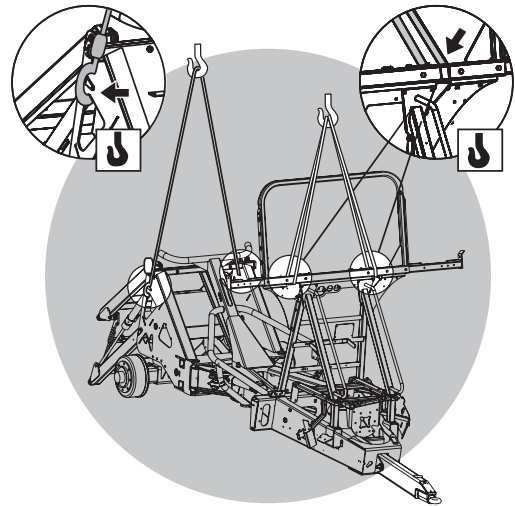

Pulling the sprayer at the tie down hooks

For moving the sprayer or loading it to e.g. a truck it can be pulled in the hooks at the rear-end (A) and front-end (B) as shown.

COMMANDER 4500

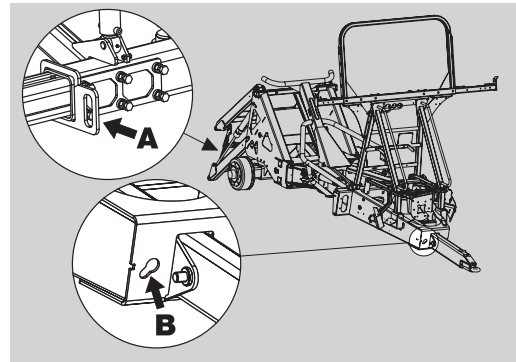

COMMANDER 5500/7000

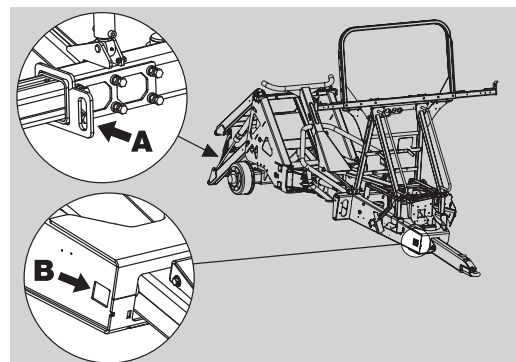

Before putting the sprayer into operation

Although the sprayer has been supplied with a strong and protective surface treatment on steel parts, bolts etc. in the factory, it is recommended to apply a film of anti-corrosion oil (e.g. CASTROL RUSTILO or SHELL ENSIS FLUID) on all metal parts in order to avoid chemicals and fertilizers discoloring the enamel.

If this is done before the sprayer is put into operation for the first time, it will always be easy to clean the sprayer and keep the enamel clean for many years. This treatment should be carried out every time the protection film is washed off.

4 - Sprayer setup

Hydraulic support leg

The hydraulic support leg is driven by a separate double acting hydraulic outlet on the tractor. The support leg is stored in its retracted position when the sprayer is attached to the tractor.

To raise/lower the support legs

1. Unlock the leg by turning the securing grip to position (A).
2. Use the tractor's hydraulic lever to raise or lower the support leg.
3. Secure the leg by turning the grip to position (B).

 **DANGER!** Do never leave the sprayer standing unlocked on the support leg. Always double check that the lever is in position (B).

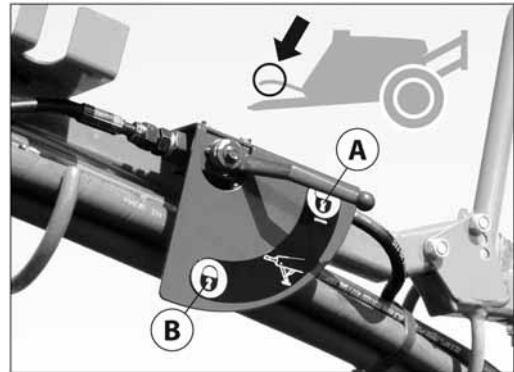

Jack up the sprayer

When the sprayer needs wheel mounting, wheel changing, or wheel bearing changing etc. then jack up the sprayer under the axle as shown.

 **DANGER!** Be sure to place sprayer at level and firm ground to avoid sprayer falling down from the jack.

 **ATTENTION!** It is good practice to use stop wedges at the opposite wheel!

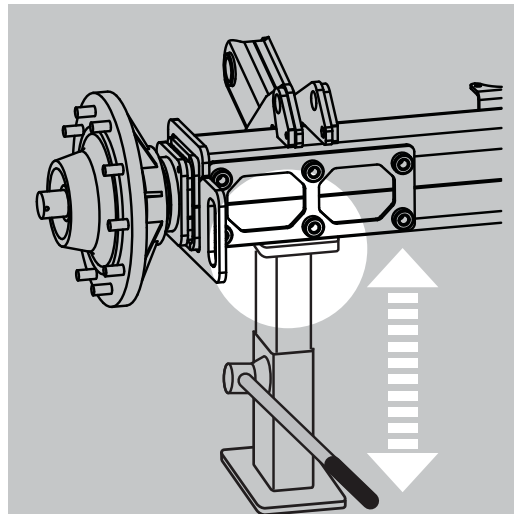

Transmission shaft

Operator safety

1. Always STOP THE ENGINE before attaching the transmission shaft to the tractor P.T.O. - most tractor P.T.O. shafts can be rotated by hand to facilitate spline alignment, when the engine is stopped.
2. When attaching the shaft, make sure that the snap lock is FULLY ENGAGED - push and pull the shaft until it locks.
3. Always keep protection guards and chains intact and make sure that it covers all rotating parts, including CV-joints at each end of the shaft. Do not use without protection guard.
4. Do not touch or stand on the transmission shaft when it is rotating -safety distance: 5' (1.5 meter). Also NEVER cross over a rotating P.T.O. shaft to reach the other side of the sprayer.
5. Prevent protection guards from rotating by attaching the chains allowing sufficient slack for turns.
6. Make sure that protection guards around the tractor P.T.O. and the implement shaft are intact.
7. Always STOP THE ENGINE and remove the ignition key before carrying out maintenance or repairs to the transmission shaft or implement.



DANGER! ROTATING TRANSMISSION SHAFTS WITHOUT PROTECTION GUARDS CAN BE FATAL.

P.T.O. installation

Always read the manufacturer's instruction book before applying any installation of the transmission shaft!

First installation of the transmission shaft is done in the following way:

1. Attach the sprayer to the tractor and set the sprayer height in the position with the shortest distance between the tractor and the sprayer pump P.T.O. shafts.
2. Stop the engine and remove the ignition key.
3. If the transmission shaft needs to be shortened, pull the shaft apart. Fit the two shaft parts to the tractor and the sprayer pump and measure how much the shaft needs to be shortened. Also mark the protection guards with the same length to be shortened.

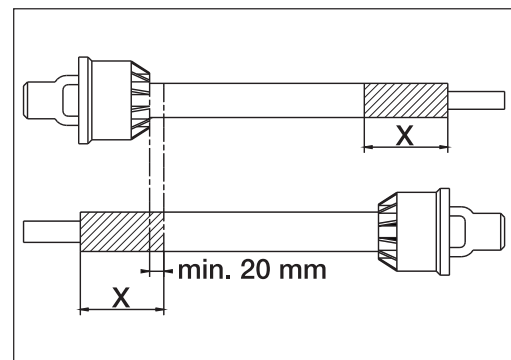

WARNING! Do only shorten the shaft if absolutely necessary!



WARNING! The shaft must always have minimum overlap of half a shaft length!

The recommended overlap (A) of the two shaft parts is $\frac{2}{3}$ of the length. The shaft must always have minimum overlap (A) of $\frac{1}{2}$ of the length.



DANGER! As P.T.O. shafts are dangerous, always read the manufacturer's instruction book before applying any changes to the transmission shaft!

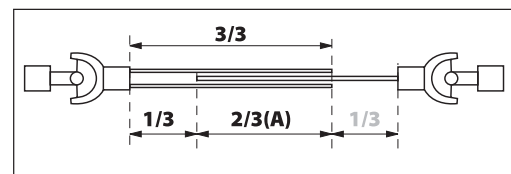
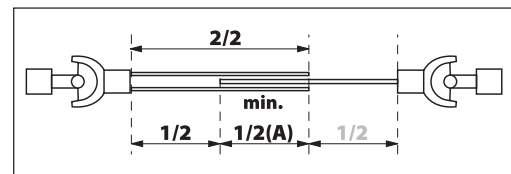

4 - Sprayer setup

Mechanical connections

Hose package support

To prevent hoses and wiring from being damaged by the tractor wheels, P.T.O. shaft etc. all hoses, cables and wires are held by the hose package support fitted to the sprayer platform.

The bracket (A) is for the storing of hydraulic and electric connectors etc. when the sprayer is disconnected from the tractor. The height of the bracket can be adjusted by the means of the bolts (B).

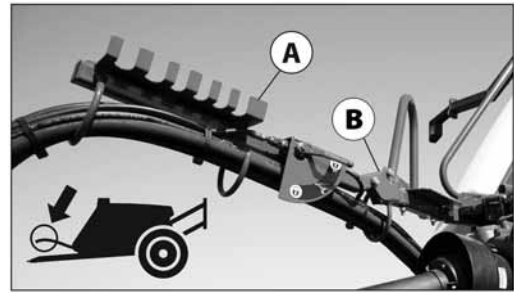

ATTENTION! Check that the length of the hoses and cables are sufficient by tight turns.



ATTENTION! A sprayer with SafeTrack requires more slack in the cables. Make sure cables are long enough in tight turns when fully steered.

SafeTrack potentiometer connection

When connecting the SafeTrack sprayer to the tractor, it is important to set up the front potentiometer on the drawbar correctly. The potentiometer must be connected to the tractor with the 2 supplied chains.



NOTE! To ensure a high precision the chains must be parallel and horizontal.



NOTE! To ensure a high precision the tractor hitch point may not have any sideways movement.

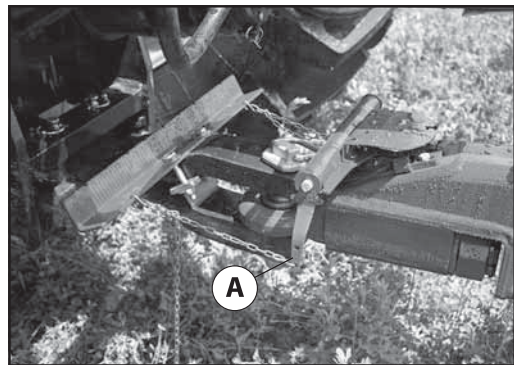

Procedure when connecting the sprayer to the tractor:

1. Connect the sprayer.
2. Drive forward to ensure the sprayer follows the tractor in a straight line.
3. Connect the two chains for the potentiometer, while ensuring the transverse potentiometer bar is perpendicular to the drawbar. The chains must be parallel and horizontal, and tightened so that the torsion levers (A) are vertical.
4. Check if the potentiometer is reading 2.50 Volt, i.e. in center position. Go to: HC 6500 / ISOBUS VT: Menu 4.5.4.6 Track sensor test and check if the Front sensor reading is 2.50 Volt.
5. If the voltage reading is not correct, then adjust the chain connection until voltage = 2.50 Volt. Allowable deviation is ± 0.05 Volt.

Hydraulic systems

General info

Ensure that the snap couplers are clean before connection!

After having operated the boom and the system has been filled with oil, check the tractor's hydraulic oil level and top up, if necessary.



DANGER! Test of the hydraulic system should be done very cautiously. There may be air trapped in the system which can cause violent movements of the boom.



DANGER! Hydraulic leaks: Never use your fingers to locate a leakage in any part of the hydraulic system. Due to high pressure, hydraulic oil may penetrate the skin.

Requirements - tractor

The hydraulic system requires:

- One double-acting outlet for the electro-hydraulic operation of the boom functions.
- One double-acting outlet for the operation of the FlexCapacity pump (optional).
- One double-acting outlet for the operation of the hydraulic support leg (5500/7000).



ATTENTION! The hydraulic hoses are marked with arrows or colored tie straps to indicate the direction of oil flow. Red tie strap = pressure. Green tie strap = Return to tank. The hoses must be hooked up to the correct outlet for the hydraulics to function properly (pressure hose to pressure outlet, return hose to tank outlet).

- Oil flow between 3 -24 gal/min (10 and 90 l/min) and a min. pressure of 2500 p.s.i. (170 bar) for Force™ booms.
- Oil flow between 13 -34 gal/min (50 and 130 l/min) and a min. pressure of 2800 p.s.i. (190 bar) for Terra Force booms.
- Maximum permissible oil pressure is 3000 p.s.i. (210 bar).
- Return flow restriction of the connected tractor must be maximum 220 p.s.i. (15 bar).
- For Load Sensing systems an oil flow of approximately 0.8 gal/min (3 l/min) at 360 p.s.i. (25 bar) supplied by the sprayer hydraulics.

4 - Sprayer setup

Open center hydraulics

The open center hydraulics block is necessary if the tractor uses open center hydraulics and/or load sensing.

The valves (1) and (2) is factory set for open center hydraulics, but if closed center hydraulics is used (also in combination with load sensing), screw in the valve (clockwise).

Certain tractor models are able to use Load Sensing without connecting an external sensing line. But if optimal sensing control pressure cannot be obtained, an external sensing line needs to be connected (3). Please consult your tractor dealer for correct setup and correct connection.



WARNING! Before operating the hydraulics, the valve should be set according to the specific tractor model. If you are unsure of the type of hydraulic system in your tractor, please contact your tractor dealer.

Combinations of settings for flow element and circuit value:

Valve no.	1	2	3 (LS port)
Open center	Out	Out	Not connected
Closed center	In	In	Not connected
Load sensing (LS)	In	Out*	Connected

*if tractor requires pressure relief, contact your tractor dealer for further advice.



WARNING! Always be sure to fully open or close the open/closed center selection valves. Failure to do so may cause damage to vital pump parts.



WARNING! It is essential that connectors on sensing line are kept totally clean. Failure to do so can result in impurities entering the pump and thereby cause damages to vital pump parts.

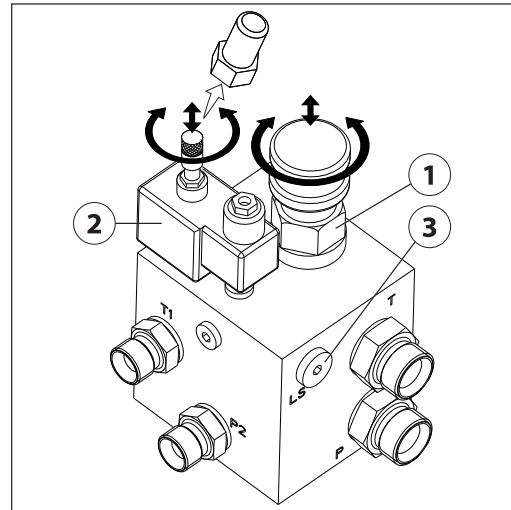

Electrical connections

Installation of control unit brackets

Find a suitable place in the tractor cabin to mount the control units. Best recommended position is to the right of the driver seat.

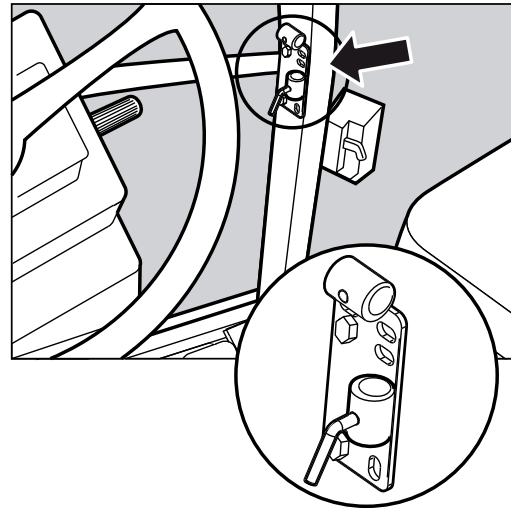

The supplied tractor pillar bracket (A) has a hole spacing of 3.9 in. (100 mm) and 4.7 in. (120 mm) that fits most tractors. Threaded mounting holes may be hidden behind front corner cover. Check tractor instructions manual for information regarding attachment points.

Three mounting tubes (B) are supplied. One, two or all three may be used. They can be bent and shortened. A spacer (C) is also supplied to allow further attachment possibilities. Find the best solution for your tractor or vehicle.

Tube (B) plate is staggered so that, if correctly orientated, all boxes will line up.

 ATTENTION! See also the controllers instruction book for further details of fitting the controller equipment.

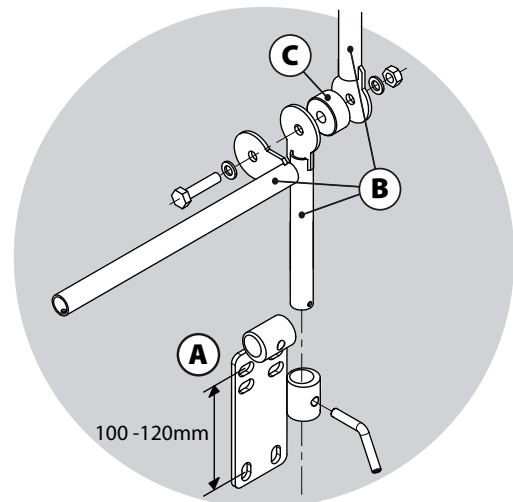

Road safety kit

Connect the plug for rear lights to the tractor's 7-pin socket, and check the function of rear lights, stop lights and direction indicators on both sides before driving.

The wiring is in accordance with ANSI/ASAE S279.11. See section "Electrical connections" on page 86.

 ATTENTION! Turn OFF all work lights when driving on public roads!

4 - Sprayer setup

Power supply

Power requirement is 12V DC. Always note polarity! For proper function of the electric equipment, the wires must have the following recommended cross sectional areas and correct fuses to ensure a sufficient power supply. The delivered power connectors follows the standard of most newer tractors. If you have a tractor with another power connector, it is necessary to disassemble the connector and fit it to the actual tractor connector.

The number and type of connectors may vary on the specific sprayer, depending on its equipment.

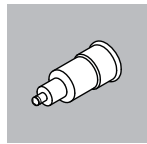
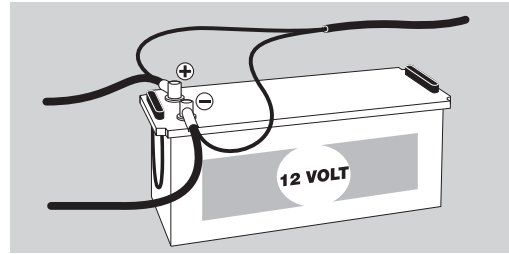

CIGAR CONNECTOR

Spray control unit requires:
Wire 2.5mm², Fuse 10 Amp
Hydraulic control unit requires:
Wire 10 awg. (4.0 mm²), Fuse 16 Amp

JOB COM CONNECTOR

The unit requires:
Wire 6.0 mm², Fuse 25 Amp

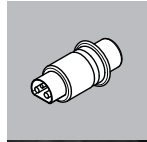

ISO POWER CONNECTOR

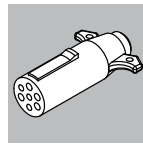

7 POLE TRAFFIC LIGHT CONNECTOR

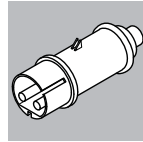

WORKING LIGHT CONNECTOR

The unit requires:
Wire 10.0 mm², Fuse 30 Amp

Speed transducer for sprayer

The speed transducer and speed ring are located at the inside of the sprayer's right wheel. The sensor is an inductive type that requires a metallic protrusion like a speed ring to pass by it to trigger a signal.

Adjustment

1. Assure that the speed ring is correctly fitted to the wheel, so that the arrow (A) follows the forward rotation of the wheel.
2. Adjust so the sensor lines up in the middle of the gaps in vertical direction.



ATTENTION! If necessary readjust plate on the axle.

3. Adjust air gap (B) to 1/8" (3.0 mm). Use feeler gauge or similar tool.
4. After adjustment, rotate the wheel. Verify air gap variation of less than +/-0.02" (+/-0.5 mm). Check this for the entire circumference.



NOTE! Air gap variation adjustment is made using the carriage bolts for the speed ring.

5. Verify Speed at the controller.



ATTENTION! Correct fitting is indicated by continuous flashing from transducer when the wheel rotates.

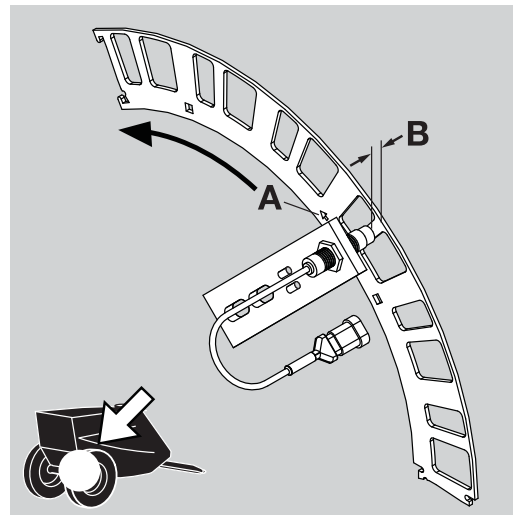

Liquid system

CycloneFilter

Standard filter size is 80 mesh and can be changed by opening the filter top. Check condition of O-rings and lubricate if necessary or replace if damaged before reassembly.



DANGER! Never open the Cyclone filter unless the suction SmartValve is turned to the unused position and the pressure SmartValve is turned to "Main tank". Otherwise, spraying liquid may hit you when opening the filter, and drain from the main tank!



4 - Sprayer setup

Track gauge, axles and wheels

Altering the track width (adjustable axle)

The track width of the sprayer can be infinitely adjusted from 60" to 90" as follows:

Altering procedure

1. Measure the current track width (center RH tire to center LH tire). Each side must be extended or retracted half the desired alteration.
2. Attach the sprayer to tractor and engage tractor parking brake.
3. Place stop wedges in front of, and behind RH wheel. Jack up LH wheel, support and secure sprayer body.
4. Loosen the jam nuts and bolts (A) for LH wheel axle.
5. Extend or retract the axle. A hand cart and a rod will facilitate the operation.
6. Lower the LH wheel.
7. Tighten the clamp bolts (A) to a torque of 185 Ft/lb (250 Nm) and lock the bolts with the jam nuts.
8. Repeat the procedure on RH wheel.
9. Check if the distance from center tire to center of rear frame is equal at RH and LH.
10. Re-tighten bolts and wheel bolts to specified torque after 8 hours of work.

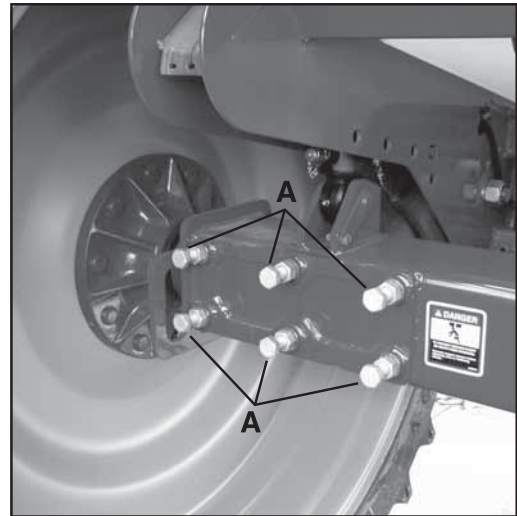

ATTENTION! The wider the track width, the better the stability of the sprayer. HARDI® recommends to work with widest possible track width.



ATTENTION! The track width can be altered in the range from 60" to 90" in combination of above adjustment and turning of the rims (wheel offset).

Changing the wheel offset

1. To change the wheel offset, the LH and RH wheels must be swapped in order to turn the rim dish and keep the correct tread direction (tread up in front).
2. Jack up the frame behind both wheels, support and secure sprayer body.
3. Remove both LH and RH wheels and swap sides (keeping the tread direction the same). Tighten wheel bolts to specified torque.

See "50 hours service - Wheel nuts" on page 67 for proper torque and tightening sequence of wheel hubs to rims.



WARNING! Securely support the sprayer while swapping wheels. Never attempt to swap wheels with liquid in the tank. Always secure the rear frame when swapping wheels.

4 - Sprayer setup

Dual tire setup - 2014 (optional)

Two different dual tire kits are available for the COMMANDER:

22" row spacing (88"/132"): HARDI® ref. no. 83348403

30" row spacing (60"/120"): HARDI® ref. no. 83348503

1. Attach the sprayer to tractor and engage tractor parking brake.
2. Place stop wedges in front of, and behind RH wheel. Jack up LH wheel, support and secure sprayer body.
3. Remove 8 of the 10 wheel nuts, leaving 2 wheel nuts opposite each other to secure the inner wheel.



NOTE! Longer stud bolts (A) are included for earlier model sprayers with shorter stud bolts.

4. Attach dual spacer (B) or (C) to inner rim using the 8 wheel nuts (D) removed in step 3.

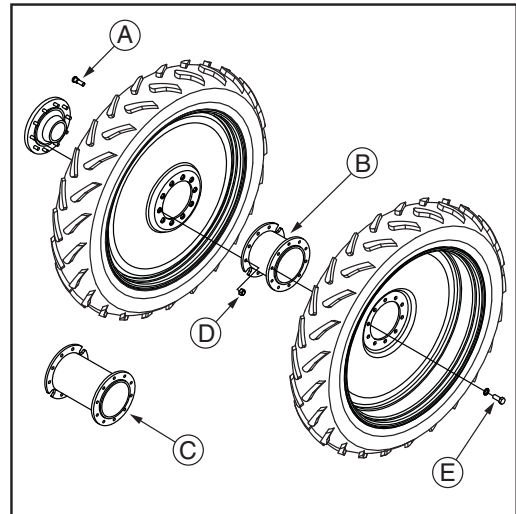

NOTE! Inner side of dual spacer has 2 notches to allow space for wheel nuts left on inner wheel. Outer side of dual spacer is threaded for outer wheel bolts.

5. Attach outer LH tire to dual spacer with supplied wheel bolts and lock washers (E). Make sure the distance between the center of inside tire to center of outside tire is 22" or 30". Wheels may need to be reversed and exchanged.
6. See "50 hours service - Wheel nuts" on page 67 for proper torque and tightening sequence.
7. Repeat the procedure for RH wheels.
8. Re-tighten bolts and wheel nuts to specified torque after 8 hours of work.
9. Check the distance between the center of inside LH tire to center of inside RH tire. The distance must be 88" for 22" duals, or 60" for 30" duals. If necessary, adjust the track width. See "Altering the track width (adjustable axle)" on page 42.



WARNING! Securely support the sprayer during axle adjustments. Never attempt to adjust axles with liquid in the tank. Always block wheels on opposite side when adjusting axles.

4 - Sprayer setup

Dual tire setup - Pre 2014 (optional)

Two different dual tire kits are available for the COMMANDER:

22" row spacing (88"/132"): HARDI® ref. no. 70059503

30" row spacing (60"/120"): HARDI® ref. no. 70059603

1. Attach the sprayer to tractor and engage tractor parking brake.
2. Place stop wedges in front of, and behind RH wheel. Jack up LH wheel, support and secure sprayer body.
3. Remove LH tire and set aside. Install supplied LH tire (chamfered holes) and secure with supplied inner bud wheel nuts. Tire offset must be as shown in order to maintain 22" or 30" spacing between center of inside tire to center of outside tire.
4. Attach dual spacer and secure with supplied outer bud wheel nuts (flat side towards rim).
5. Attach outer LH tire (removed in step 3) to dual spacer with supplied wheel studs and wheel nuts removed in step 3. Make sure the distance between the center of inside tire to center of outside tire is 22" or 30". Wheels may need to be reversed and exchanged.
6. See "50 hours service - Wheel nuts" on page 67 for proper torque and tightening sequence.
7. Repeat the procedure for RH wheels.
8. Re-tighten bolts and wheel bolts to specified torque after 8 hours of work.
9. Check the distance between the center of inside LH tire to center of inside RH tire. The distance must be 88" for 22" duals, or 60" for 30" duals. If necessary, adjust the track width. See "Altering the track width (adjustable axle)" on page 42.

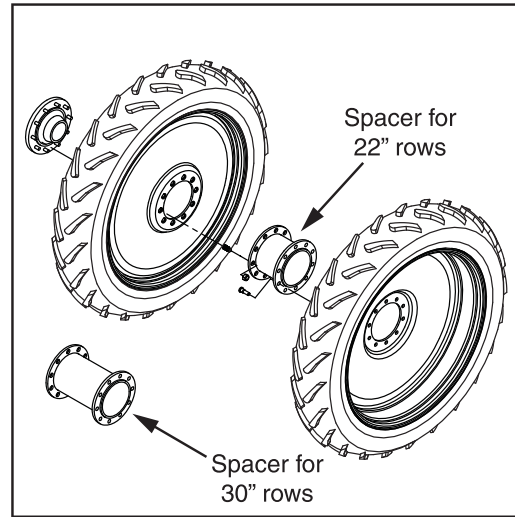

WARNING! Securely support the sprayer during axle adjustments. Never attempt to adjust axles with liquid in the tank. Always block wheels on opposite side when adjusting axles.



ATTENTION! The wheels supplied with the dual tire kits must be used on the inside tires only. The rims have chamfered holes to match the supplied inner bud wheel nuts.

R.P.M. Transducer for pump

The R.P.M. transducer is located at the inner side of the P.T.O. shield. The sensor is an inductive type that requires metallic protrusions to pass by it to trigger a signal.

Adjustment

1. Adjust air gap (A) to 3/16" (4 mm). Use a feeler gauge or similar tool.
2. After adjustment, spin the shaft. Verify air gap variation of less than +/-0.02" (+/-0.5 mm). Check this for the entire circumference.
3. Verify transducer function:
 - ISOBUS VT:
Monitor menu [4.5.4.9.6 PTO pump frequency].

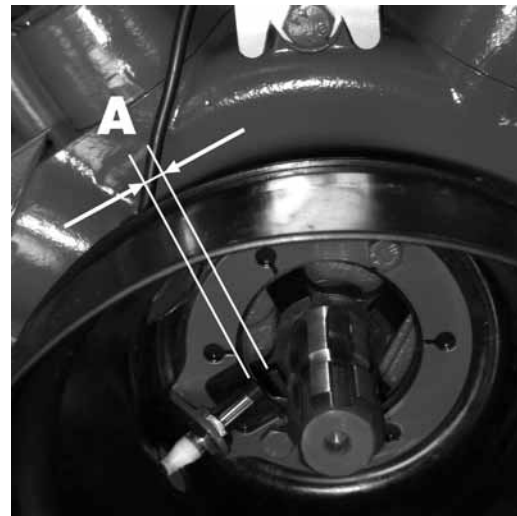

Boom

Safety info

The boom must not be folded/unfolded while driving! Never use the folding/unfolding functions before the sprayer has been stopped! Failure to do so will damage the boom.



DANGER! Before unfolding the boom it is important to connect the sprayer to the tractor to prevent overbalancing of the sprayer.



DANGER! When folding or unfolding the boom, make sure that no persons or objects are in the operating area of the boom.



DANGER! Always follow the guidelines listed below when driving in areas with overhead power lines:

Never use the folding/unfolding functions in areas with overhead power lines.

Unintended boom movements may cause contact with overhead power lines.

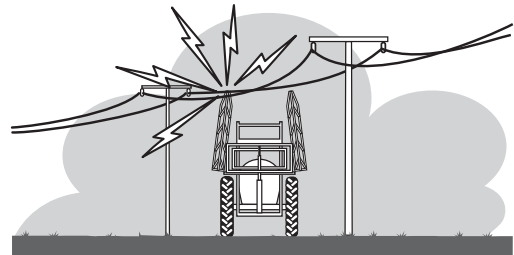

ATTENTION! A label (ref. no. 10533003) is located on the sprayer's drawbar. This label must be visible to the operator when hooking up the sprayer.



ATTENTION! Only unfold and fold the boom on level ground.

Boom Operator's Manual

A separate "Boom Operator's Manual" is supplied with your sprayer and contains detailed information on boom safety, set-up, operation and maintenance.



DANGER! Important information on Safety, Operation and Maintenance specific to your boom configuration is detailed in the "Boom Operator's Manual" supplied with your sprayer. It must be read and fully understood by anyone intending to operate this equipment. Failure to do so could result in serious personal injury or death.

5 - Operation

Maneuvering of the FORCE™ boom



WARNING! The center lock automatically turns ON when pressing one of the folding buttons. Boom folding is not possible if the center is unlocked. A manual override of the center lock is possible by activating switches 2 or 3 on the SetBox.



WARNING! Only operate the folding functions when the sprayer is stationary! Failure to do so may damage the boom. The pendulum lock automatically opens at speeds exceeding 0.9 mph (1.5 km/h)!





ATTENTION! If a folding sequence is not completed, a warning message on the Hardi display will ask you to complete this sequence before starting next sequence.



ATTENTION! Only buttons relevant for boom functions are mentioned here.

To unfold the boom using the SetBox & Grip controls

1. Press the boom lift button (H) to lift the boom clear of the transport brackets.
2. Press and hold (A) and (C) to tilt boom wings up.
3. Press and hold button (5) to unfold the inner sections completely (approximately 5 sec. or a warning will appear). Check that the center locked symbol  is visible in the display.
4. Press and hold (B) and (D) to tilt boom wings down.
5. Press and hold button (7) to unfold 1st outer sections.
6. Press and hold button (8) to unfold 2nd outer sections (120'-132' tri-fold booms only).
7. Press and hold the boom down button (I) to lower the boom to the correct working height.
8. If not unlocked, then press (2) and  symbol appears in display until pendulum is unlocked. This takes approximately 10 seconds.
9. WARNING! The center lock automatically opens when you begin to drive. Drive slowly until the center is completely unlocked. The boom must be unlocked before engaging AutoTerrain system.

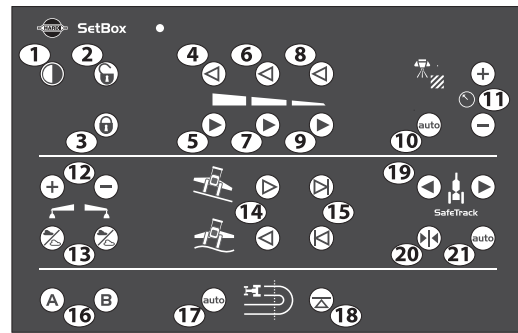

To fold the boom using the SetBox & Grip controls

1. Press the boom lift button (H) to raise the boom to the highest possible position.
2. Press and hold button (8) to fold 2nd outer sections (120'-132' tri-fold booms only).
3. Press and hold button (6) to fold 1st outer sections.
4. Press and hold (A) and (C) to tilt boom wings up.
5. Press and hold button (4) to fold the inner sections.
6. Press the boom down button (I) to lower the boom until it rests in the transport locks.
7. Press and hold (B) and (D) to tilt boom wings down into the transport rests.

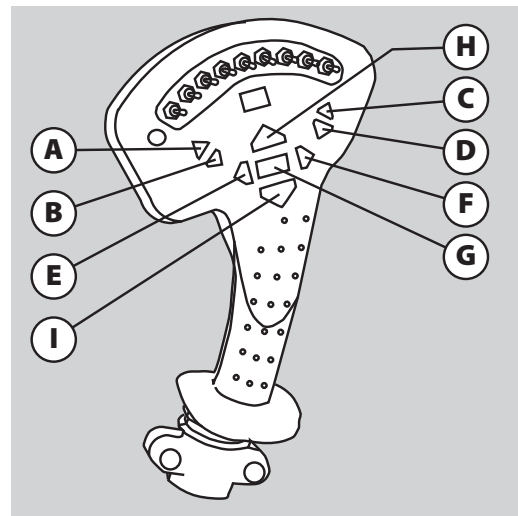

Maneuvering of the boom - TERRA FORCE



WARNING! The pendulum lock automatically turns ON when pressing one of the folding buttons. Boom folding is not possible if the pendulum is unlocked. A manual override of the pendulum lock is possible by activating switches 2 or 3 on the SetBox.



WARNING! Only operate the folding functions when the sprayer is stationary! Failure to do so may damage the boom. The pendulum lock automatically opens at speeds exceeding 0.9 mph (1.5 km/h)!





ATTENTION! If a folding sequence is not completed, a warning message on the Hardi display will ask you to complete this sequence before starting next sequence.



ATTENTION! Only buttons relevant for boom functions are mentioned here.

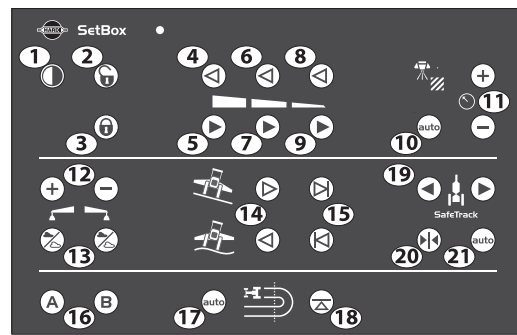

To unfold the boom using the SetBox & Grip controls

8. Press the boom lift button (H) to lift the boom clear of the transport brackets.
9. Press and hold (A) and (C) to tilt boom wings up.
10. Press and hold button (5) to unfold the inner sections completely (approximately 5 sec. or a warning will appear). Check that the pendulum locked symbol  is visible in the display.
11. Press and hold (B) and (D) to tilt boom wings down.
12. Press and hold button (7) to unfold the 1st outer sections.
13. Press and hold button (9) to unfold the 2nd outer sections (120'-132' tri-fold booms only).
14. Press and hold the boom down button (I) to lower the boom to the correct working height.
15. If not unlocked, then press (2) and + symbol appears in display until pendulum is unlocked. This takes approximately 10 seconds.



WARNING! The pendulum lock automatically opens when you begin to drive. Drive slowly until the pendulum is completely unlocked. The boom must be unlocked before engaging AutoTerrain system.

To fold the boom using the SetBox & Grip controls

1. Press and hold button (18) to set neutral slant angle (no slant).
2. Press the boom lift button (H) to raise the boom to the highest possible position.
3. Press and hold button (8) to fold the 2nd outer sections (120'-132' tri-fold booms only). The + symbol appears in display until pendulum is locked. This takes approximately 10 seconds.
4. Press and hold button (6) to fold the 1st outer sections. Check that the pendulum lock symbol  is visible in the display.
5. Press and hold (A) and (C) to tilt boom wings up.
6. Press and hold button (4) to fold the inner sections.
7. Press the boom down button (I) to lower the boom until it rests in the transport locks.
8. Press and hold (B) and (D) to tilt boom wings down into the transport rests.

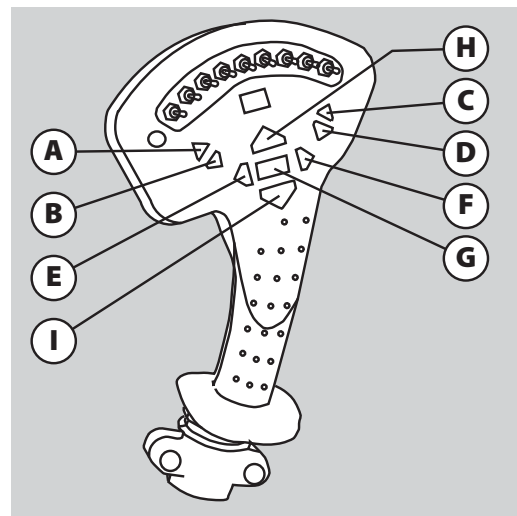

5 - Operation

Liquid system

Filling/washing location requirements

When filling the sprayer with chemicals and water it is important to avoid spot contamination by spray chemicals in order to protect the subsoil water resources.

- A. If the sprayer is always filled at the same place, a special filling/washing location should be established. This should have a hard, liquid-impenetrable surface (e.g. concrete) and edges securing against run-off to the surrounding areas. The place should be drained to an adequate receptacle (e.g. slurry tank or similar).

Any spillage or washings should be retained and diluted in order to be distributed on a larger area to ensure minimal environmental impact and avoid build-up of larger chemical concentrations at one spot.

- B. Alternatively the sprayer can be filled in the field where the spraying is to take place. If so, choose a different location for each refilling.

If no other requirements of distances exist, the filling should not take place closer than:

- 1) 300 yards (meters) from any water supplies for drinking purposes,
- 2) 25 yards (meters) from treatment sumps and sewer drainage systems, and
- 3) 50 yards (meters) from surface water (watercourses, lakes and coastal waters) and from nature reserves.



ATTENTION! Legislation and requirements vary. Always follow local legislation in force at any time.



NOTE! It is the responsibility of the sprayer owner/operator to comply with all relevant legislation. HARDI® cannot undertake any responsibilities for incorrect operation and use.

Filling of water

The tank should normally be filled 1/3 with water before adding chemicals. Always follow the instructions given on the chemical container!



WARNING! If the sprayer is put aside with liquid in the main tank, all MANIFOLD valves must be closed.

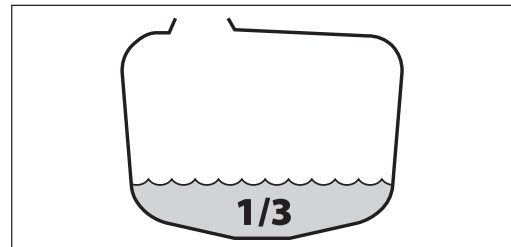

Filling through tank lid

Water is filled into the tank by removing the tank lid located at front of the sprayer tank which is accessible from the platform. It is recommended to use as clean water as possible for spraying purposes. Always fill water through the strainer basket to prevent foreign particles from entering the tank. An overhead tank can be used in order to obtain high filling capacity.



WARNING! Do not let the filling hose enter the tank. Keep it outside the tank, pointing towards the filling hole. If the hose is led into the tank and the water pressure drops at the water supply plant, chemicals may be siphoned back and contaminate the water supply lines and source.



WARNING! The water supply line should be provided with a check valve as additional safety precaution. Follow local legislation in force at any time.

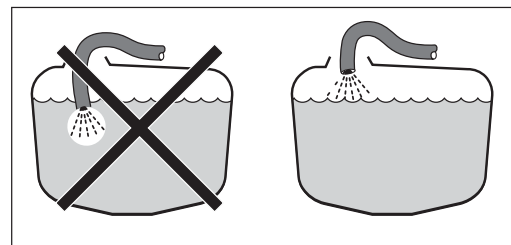

WARNING! The water supply should be provided with a meter to avoid spillage by over-filling. Follow local legislation in force at any time.

Main Tank Quick Fill

The main tank is filled via the 3" quick coupler located behind the TurboFiller:

1. Remove plug from Quick Fill valve and connect filling hose from water supply.
2. Open the Quick Fill valve and fill tank to desired level.
3. Keep an eye on the main tank level indicator in order not to overfill the tank.
4. Close the Quick Fill valve and remove the filling hose.
5. Replace the plug to the Quick Fill coupler when filling is complete.

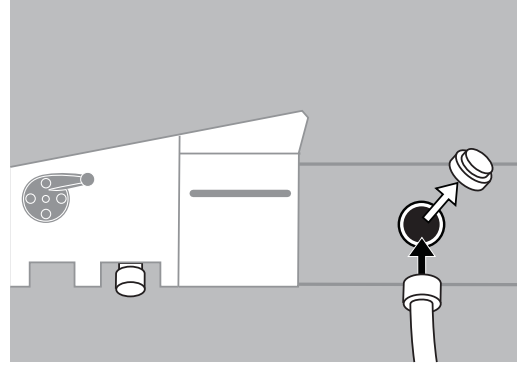

Filling of rinsing tank

The rinsing tank is filled via the 2" quick coupler at the manifold system:

1. Remove plug from Quick Fill valve and connect filling hose from water supply.
2. Open the Quick Fill valve and fill tank to desired level.
3. Keep an eye on the level indicator in order not to overfill the tank.
4. Close the Quick Fill valve and remove the filling hose.
5. Replace the plug to the Quick Fill coupler when filling is complete.

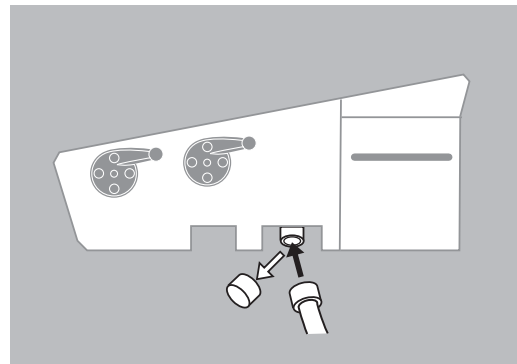

Capacity: approximately 120 gallons (450 liters).



ATTENTION! Only fill rinsing tank with clean water! To avoid algae developing in the rinsing tank, always drain the rinsing tank if the sprayer is not in use for a long period of time.



ATTENTION! For cleaning purposes etc. the rinsing tank is also accessible via the tank lid on top of the tank.

Filling of clean water tank

To fill the clean water tank:

1. Remove the tank lid.
2. Fill with clean water.
3. Replace the tank lid.

For use of water:

- Turn the ball valve lever to open. The ball valve is located on the valve cover.

The water from this tank is for hand washing, cleaning of clogged nozzles etc. Only fill the clean water tank with clean water.

Capacity: 4.5 gal. (20 liters).

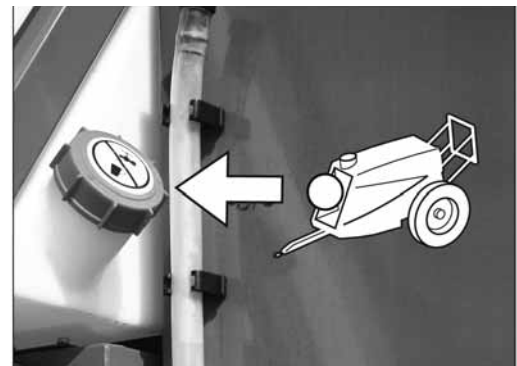

WARNING! Although the clean water tank is only filled with clean water, this water must NOT be used for drinking.

5 - Operation

Safety precautions - crop protection chemicals



WARNING! Always be careful when working with crop protection chemicals!



WARNING! Always wear proper protective clothing before handling chemicals!

Personal protection

Depending on chemical type, protective gear/equipment should be worn to avoid contact with the chemicals, e.g.:

- Gloves
- Waterproof boots
- Headgear
- Respirator
- Safety goggles
- Chemical resistant overall



WARNING! Protective clothing/equipment should be used when preparing the spray liquid, during the spray job and when cleaning the sprayer. Follow the chemical manufacturer's instructions given on the chemical label.



WARNING! It is always advisable to have clean water available, especially when filling the sprayer with the chemical.



WARNING! Always clean the sprayer carefully and immediately after use.



WARNING! Only mix chemicals in the tank according to directions given by the chemical manufacturer.



WARNING! Always clean the sprayer before changing to another chemical.

Filling chemicals through tank lid

The chemicals are filled through the tank lid - Note instructions on the chemical container!



WARNING! Be careful not to slip or splash chemicals when carrying chemicals up to the tank lid!

1. Make sure the spray control unit is switched off.
2. Turn the suction SmartValve handle to "Suction from main tank". Turn the pressure SmartValve handle to an unused function. Turn the Agitation valve to "Agitation".
3. Engage the pump and set P.T.O. revolutions to recommended pump r.p.m.
4. Add the chemicals through the main tank hole.
5. When the spray liquid is well mixed, leave the suction SmartValve handle turned to "Suction from Main tank" and turn pressure SmartValve handle to "Spraying" position. Keep P.T.O. engaged so the spray liquid is continuously agitated until it has been sprayed on the crop.

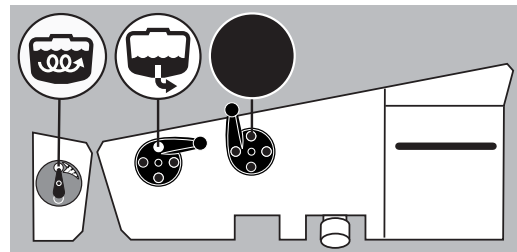

Filling liquid chemicals by HARDI® TurboFiller

1. Fill the main tank at least 1/3 with water (unless otherwise stated on the chemical container label).
2. Turn the suction SmartValve handle to "suction from Main tank". Turn the pressure SmartValve handle to "TurboFiller". Adjust Agitation valve to desired setting.



ATTENTION! For increased suction from the TurboFiller, the AgitationValve can be kept closed.

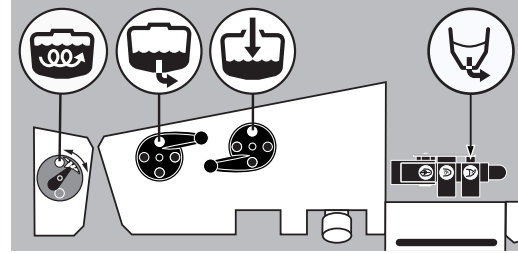

3. Engage the pump and set P.T.O. revolutions to 540 r.p.m. or 1000 r.p.m. depending on pump model.
4. Open TurboFiller lid. Measure the correct quantity of chemical and fill it into the hopper.



DANGER! Always wear face shield and other appropriate personal safety equipment when filling chemicals.



ATTENTION! The scale in the hopper can only be used if the sprayer is parked on level ground! It is recommended to use a measuring jug for best accuracy.

5. Engage the hopper transfer device by opening the TurboFiller suction valve transfer chemicals to the main tank. The TurboFiller suction valve must be open for at least 20 seconds after the chemical is no longer visible in the hopper in order to completely empty the transfer hoses into the main tank.



DANGER! If the TurboFiller and the transfer hoses are not completely emptied there are risk of chemicals being siphoned out of the main tank!

6. If the chemical container is empty, it can be rinsed by the Chemical Container Cleaning device. Place the container over the multi-hole nozzle and push the container cleaning lever.



DANGER! In order to avoid spray liquid hitting the operator, do not press lever unless the multi-hole nozzle is covered by a container as spray liquid may otherwise hit the operator!



ATTENTION! Rinsing device uses spray liquid to rinse containers for concentrated chemicals. Always rinse the chemical containers with clean water several times until they are clean before disposal.

7. Flush the TurboFiller with clean water from the Rinsing tank. The TurboFiller suction valve must be open for at least 20 seconds after the rinse water is no longer visible in the hopper in order to completely empty the transfer hoses into the main tank.



ATTENTION! If not flushed with clean water, the hopper rinsing device uses spray liquid for rinsing the hopper! Cleaning the TurboFiller must always be done when the spray job is ended and together with the entire sprayer - a cleaning after the last filling and before spraying the last tankful does not ensure a clean TurboFiller!

8. Close TurboFiller suction valve when the hopper has been rinsed and close the lid.
9. If closed, turn the AgitationValve to "Agitation".

10. When the spray liquid is well agitated, turn handle of the pressure SmartValve to "Spraying" position. Keep P.T.O. engaged so the spray liquid is continuously agitated until it has been sprayed on the crop.

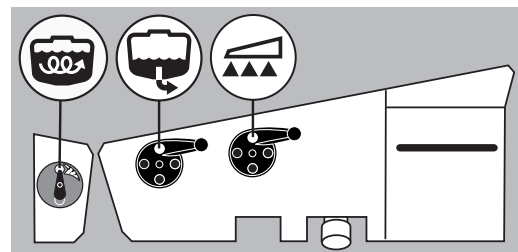

5 - Operation

Filling powder chemicals by HARDI® TurboFiller

1. Fill the main tank at least 1/2 with water (unless otherwise stated on the chemical container label). See section "Filling of water".
2. Turn the suction SmartValve handle to "suction from Main tank". Turn the pressure SmartValve handle to "TurboFiller". Adjust Agitation valve to desired setting.

 ATTENTION! For increased suction from the TurboFiller the AgitationValve can be kept closed.

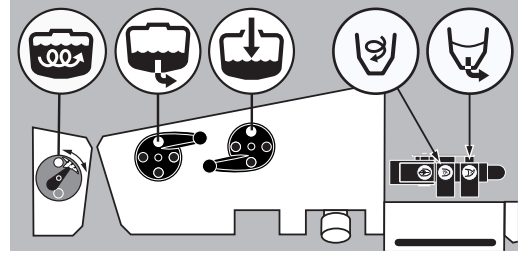



3. Engage the pump and set P.T.O. revolutions to 540 r.p.m. or 1000 r.p.m. depending on pump model.
4. Open TurboFiller lid. Open TurboDeflector valve and TurboFiller suction valve.
5. Measure the correct quantity of chemical and sprinkle it into the hopper as fast as the transfer device can flush it down. The TurboFiller suction valve must be open for at least 20 seconds after the chemical is no longer visible in the hopper in order to completely empty the transfer hoses into the main tank.

 DANGER! If the TurboFiller and the transfer hoses are not completely emptied there are risk of chemicals being siphoned out of the main tank!

 DANGER! Always wear face shield and other appropriate personal safety equipment when filling chemicals.

6. If the chemical container is empty, it can be rinsed by the Chemical Container Cleaning device. Place the container over the multi-hole nozzle and push the container cleaning lever.

 DANGER! In order to avoid spray liquid hitting the operator, do not press lever unless the multi-hole nozzle is covered by a container as spray liquid may otherwise hit the operator.

 ATTENTION! Rinsing device uses spray liquid to rinse containers for concentrated chemicals. Always rinse the chemical containers with clean water several times until they are clean before disposal.

7. Flush the TurboFiller with clean water from the Rinsing tank. The TurboFiller suction valve must be open for at least 20 seconds after the rinse water is no longer visible in the hopper in order to completely empty the transfer hoses into the main tank.

 ATTENTION! If not flushed with clean water, the hopper rinsing device uses spray liquid for rinsing the hopper! Cleaning the TurboFiller must always be done when the spray job is ended and together with the entire sprayer - cleaning after the last filling and before spraying the last tankful does not ensure a clean TurboFiller!

8. Close TurboFiller suction valve when the hopper has been rinsed and close the lid.
9. If closed, turn the AgitationValve to "Agitation".

10. When the spray liquid is well agitated, turn handle of the pressure SmartValve to "Spraying" position. Keep P.T.O. engaged so the spray liquid is continuously agitated until it has been sprayed on the crop.

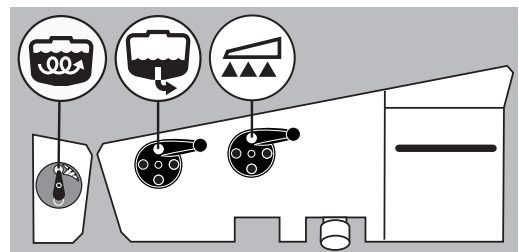

TurboFiller rinsing

Rinsing the TurboFiller and chemical containers are done as follows:

Cleaning empty containers - TurboFiller lid is open

1. Put container over the rotating flushing nozzle in the middle of the TurboFiller so that the nozzle is inside the container.
2. Simultaneously press the Chemical Container Cleaning lever and the TurboFiller suction valve. This rinses the chemical container with the flushing nozzle while the rinsing liquid is emptied out of the TurboFiller.

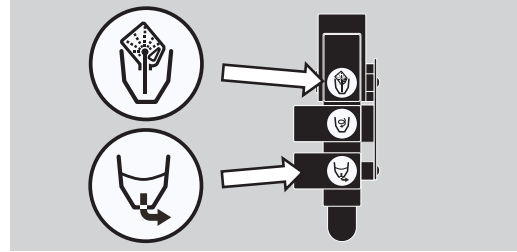

TurboFiller rinsing - TurboFiller lid is closed

1. Close TurboFiller lid.
2. Turn the suction SmartValve handle to "Rinsing tank".
3. Simultaneously press the Chemical Container Cleaning lever and the TurboFiller suction valve. This rinses the hopper with the flushing nozzle while the rinsing liquid is emptied out of the TurboFiller.
4. Rinse the hopper for 30-40 seconds.
5. Open the lid to inspect if the TurboFiller is empty. If not, close the lid again and press the TurboFiller suction valve until the TurboFiller is empty.
6. After the last flushing, leave the TurboFiller suction valve open for at least 20 seconds after the rinse water is no longer visible in the hopper in order to completely empty the transfer hoses into the main tank.



ATTENTION! The TurboFiller needs to be cleaned thoroughly after finishing spraying again to be sure it is clean before spraying other crops that may be sensitive to the chemicals just used. See section "Cleaning" on page 56 for details.

5 - Operation

Operating the control units while spraying

The control units control the following spray functions:

1. Power ON/OFF/status LED. LED must be ON.
2. Automatic spray pressure regulation.
The regulation valve controls the main spray pressure. This is default selection when the controller is powered ON, and it should remain here during normal spraying.
3. Manual spray pressure regulation. Under normal spraying these should not be used as the regulation valve does this automatically.
4. Foam marker blob interval. Regulates the blob interval for the optional foam marker.
5. Foam marker (Left/Right). Turns the optional foam marker ON for each side.
6. Optional function (A/B). If extra equipment is added, it can be controlled from here.

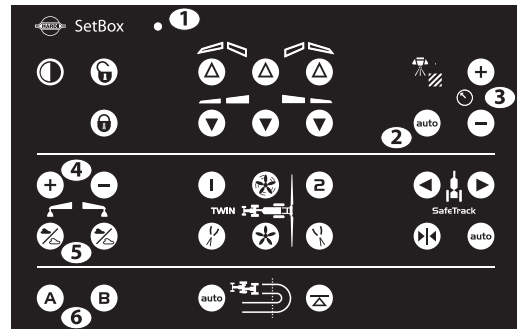

- A. Power ON/OFF/status LED. LED must be ON.
- B. Section valves. Turns single sections on or off. Lever up is OFF and down is ON.
- C. Master ON/OFF.

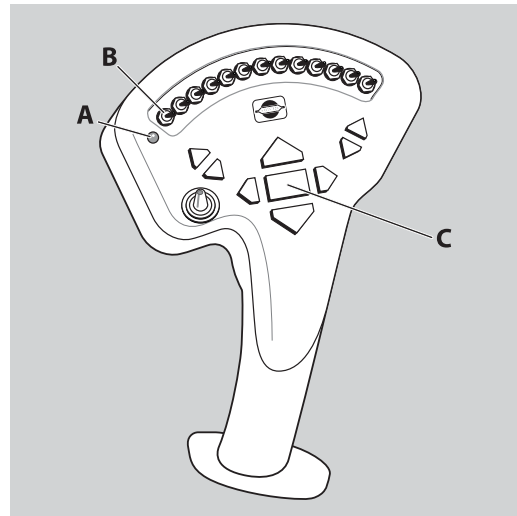

Use when spraying

- On the sprayer, turn the suction valve toward "Suction from Main tank" and the pressure SmartValve toward "Spraying". Turn the agitation valve to "Agitation" if necessary.
- In order to close the entire boom, switch Master ON/OFF (C) to OFF position. This returns the pump output to the tank through the return system. The diaphragm Non-drip valves ensure instantaneous closing of all nozzles.
- In order to close one or more sections of the boom, switch the relevant distribution valve (B) to OFF position (upwards). The DynamicFluid4 system ensures that the pressure does not rise in the sections that remain open.

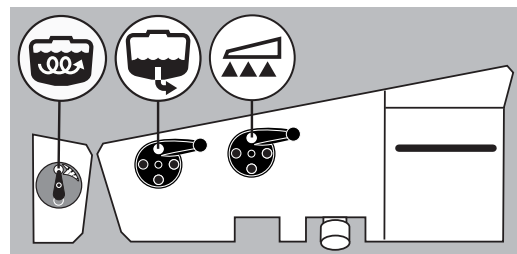

NOTE! For checking the volume application rate, please refer to the spray controller instruction book.

Before returning to refill the sprayer

If the sprayer is to be refilled at the farm or at a fixed filling place without a filling space with hard surface and drain to closed reservoir, the sprayer should be rinsed before returning to refill.

Dilute the residues of the spraying circuit, and spray it on the crop. Then rinse the sprayer on the outside with the External Cleaning Device before returning to the farm.



WARNING! Always follow local legislation in force at any time.

Agitation before resuming a spray job

If a spray job has been interrupted for a while, severe sedimentation may occur depending on the chemicals being used. Before resuming the spray job, it might be necessary to agitate sedimented material first.

1. Turn the handle at the suction valve to "Suction from main tank". Turn the pressure SmartValve handle to an unused function and turn the Agitation valve to "Agitation".
2. Engage the pump and set P.T.O. revolutions to recommended pump r.p.m.
3. Agitation will start and should be continued for at least 10 minutes.
4. Once the chemicals are mixed, spraying can resume. Turn pressure SmartValve to "Spraying" and start spraying.

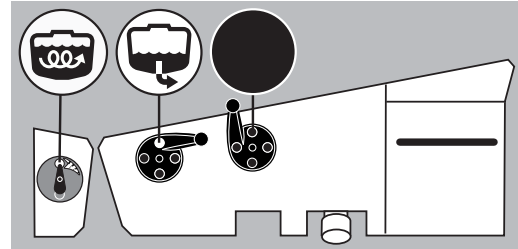

Parking the sprayer

To avoid spot contamination the sprayer should always be parked at either the washing/filling place or under a roof to avoid rainfall washing chemical residues from the sprayer's surfaces.

- Parking at the washing/filling location will retain residues.
- Always park the machine out of reach of children, animals or unauthorized persons.

Quick reference - Operation

In the following diagrams handle positions for different options are described.

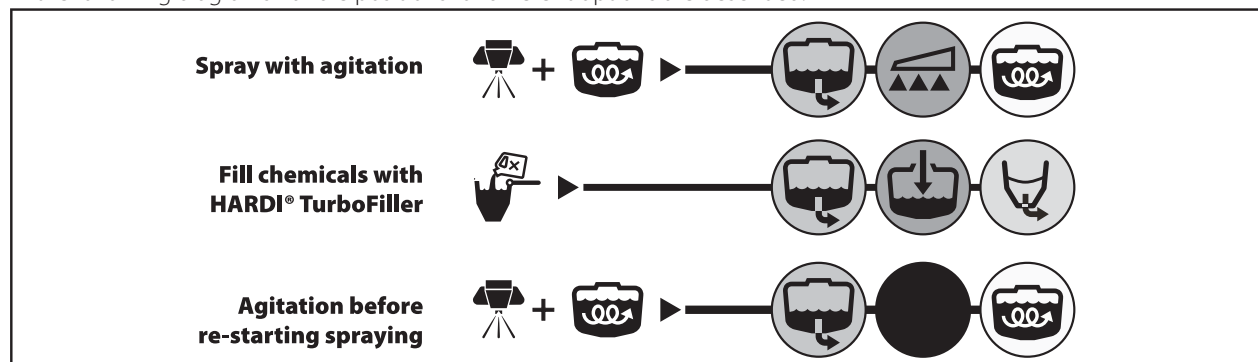

5 - Operation

Cleaning

General info

In order to derive full benefit from the sprayer for many years the following service and maintenance program should be followed.



ATTENTION! Always read the individual paragraphs. Read instructions for service/maintenance jobs carefully before starting on the job. If any portion remains unclear or requires facilities which are not available, then for safety reasons please leave the job to your HARDI® dealer's workshop.



ATTENTION!

Clean sprayers are safe sprayers.

Clean sprayers are ready for action.

Clean sprayers cannot be damaged by pesticides and their solvents.

Guidelines

1. Read the whole chemical label. Take note of any particular instructions regarding recommended protective clothing, deactivating agents, etc. Read the detergent and deactivating agent labels. If cleaning procedures are given, follow them closely.
2. Be familiar with local legislation regarding disposal of pesticides washings, mandatory decontamination methods, etc. Contact the appropriate department, e.g. Dept. of Agriculture.
3. Pesticide washings can usually be sprayed out on the field just sprayed or at a suitable cultivated area. Avoid emptying the washings at the same spot every time and keep sufficient distance to the water environment. You must prevent seepage or runoff of residue into streams, water courses, ditches, wells, springs, etc. The washings from the cleaning area must not enter sewers. Alternatively the washings can be retained in an appropriate receptacle, diluted and distributed over a larger cultivated area - see also "Filling/washing location requirements" on page 48.
4. Cleaning starts with the calibration, as a well calibrated sprayer will ensure the minimal amount of remaining spray liquid.
5. It is good practice to clean the sprayer immediately after use and thereby render the sprayer safe and ready for the next pesticide application. This also prolongs the life of the components.
6. It is sometimes necessary to leave spray liquid in the tank for short periods, e.g. overnight, or until the weather becomes suitable for spraying again. Unauthorized persons and animals must not have access to the sprayer under these circumstances.
7. If the product applied is corrosive, it is recommended to coat all metal parts of the sprayer before and after use with a suitable rust inhibitor.
8. The sprayer should always be parked under a roof to avoid rain washing off pesticides and build-up of spot contamination in the soil. If parked outside, the sprayer should be parked on the filling/washing location in order to retain possible pesticides.

Quick reference - Cleaning

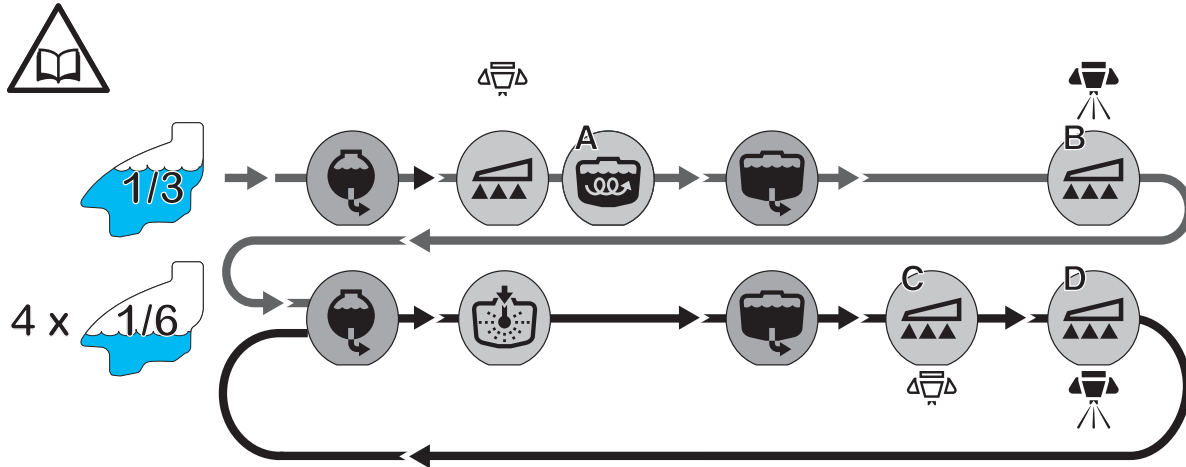

- A. Full agitation.
- B. Engage FlexCapacity pump. Spray until air comes out of nozzles.
- C. Min. 45 seconds with nozzles OFF.
- D. Spray until air comes out of nozzles.

Cleaning and maintenance of filters

Clean filters ensure:

- Sprayer components such as valves, diaphragms and operating unit are not hindered or damaged during operation.
- Nozzle blockages do not occur while spraying.
- Long life of the pump. A blocked suction filter will result in pump cavitation. The main filter protecting sprayer components is the suction filter. Check it regularly.

Use of rinsing tank and rinsing nozzles

The incorporated rinsing tank can be used for three different purposes:

- A. Full internal rinsing (in-field before cleaning or when using same chemicals again soon).
- B. External cleaning (can only be carried out on completion of "A").
- C. Rinsing spray circuit without diluting main tank content.
- D. Full internal cleaning (before storage or when switching chemicals).



ATTENTION! The cleaning procedures stated requires the TurboFiller to be cleaned out beforehand (directly after the last chemical filling). If the TurboFiller has not been cleaned, it must be cleaned before performing cleaning procedures A, B, C or D - see "TurboFiller rinsing" on page 53.



Note that cleaning the TurboFiller will use water from the rinsing tank, reducing the available quantity for cleaning procedures A, B, C or D.



ATTENTION! Do NOT add any cleaning detergents into the rinsing tank. If cleaning agents are to be used, they should be added the main tank.

5 - Operation

A. Full internal rinsing

In-field diluting of remaining spray liquid residues in the spraying circuit for spraying the liquid in the field, before cleaning the sprayer.



NOTE! This rinsing is adequate/sufficient when the sprayer is going to be used again shortly (e.g. next day) in same or similar crops (no risk by cross contamination and subsequent crop damages).



WARNING! If the next crop to be sprayed is sensitive to the latest chemical used, then a full cleaning should be carried out. See "D: Full internal cleaning (Soak wash)" on page 60.



WARNING! Never clean the sprayer if there are risks of contamination of surface or underground water! Choose a different spot for cleaning every time to avoid spot contamination to build up.

This rinsing procedure will rinse the spraying circuit and main tank as follows:

1. Empty the sprayer as much as possible. Close the agitation valve (no agitation). Allow the pump to run for at least 1 minute after the liquid fan from the nozzles has collapsed to ensure that all relevant liquid has been expelled.
2. Shut off all nozzles with the main ON/OFF button on the grip.
3. Turn suction SmartValve to "Rinsing tank" and pressure SmartValve to "Spraying". Set agitation valve to "Full agitation".
4. Engage and set the pump at approximately 300 rpm.
5. Use 1/3 (approximately 40 gal or 150 l) of the rinsing tank contents at this valve setting.
6. Close the agitation valve and turn the pressure SmartValve to "TurboFiller" for at least 3 seconds without activating the TurboFiller to burst and flush the safety valve. The TurboFiller is not flushed by this operation.
7. Turn suction SmartValve to "Main tank". Engage the auxiliary pump (FlexCapacity configurations only). Set the spraying pressure at 45-75 psi (3-5 bar). If the pressure is set outside this range the rinsing result may be insufficient.
8. Open all nozzles and spray the rinsing water from the main tank through the nozzles while driving in the field. Choose a different location each time to distribute the rinsing water over larger areas. Continue until all fluid is expelled from the boom tubes and nozzles - this may take several minutes after the spray fan has collapsed.
9. Shut off all nozzles by the main ON/OFF switch on the grip.
10. Turn the suction SmartValve to "Rinsing tank" and the pressure SmartValve to "Internal tank rinsing". Use another 1/6 (approximately 20 gal or 75 l) for this. The tank strainer should be removed to avoid shading for the rinsing nozzle.
11. Turn the suction SmartValve to "Main tank" and the pressure SmartValve to "Spraying". With the nozzles shut, allow the liquid to circulate for a minimum of 30 seconds to flush the return lines from boom to tank.
12. Open all nozzles by the main ON/OFF switch and spray the rinsing water from the main tank through the nozzles until all liquid is expelled from the boom tubes/nozzles.
13. Repeat step 9-12 another 3 times using 1/6 (approximately 20 gal or 75 l) of the rinsing tank contents in each of the 3 sequences until the rinsing tank is empty.
14. Shut off the nozzles at the main ON/OFF button once the rinsing process is complete.

B. External cleaning

This procedure is used to rinse the sprayer on the outside in the field as required with the External Cleaning Device.

i NOTE! Before attempting an external rinsing, make sure the main tank is rinsed (see "A. Full internal rinsing" on page 58) and empty! Any liquid left in the main tank will be mixed with the clean water for external rinsing!

i NOTE! Approximately 25 gal (100 l) of clean water in the rinsing tank will allow approximately 15 minutes of rinsing (Cleaning nozzle consumption is 1.6 gal/min [6 l/min] at 145 psi [10 bar pressure]).

⚠ WARNING! Never clean the sprayer if there are risks of contamination of surface or underground water! Choose a different spot for cleaning every time to avoid spot contamination to build up.

1. Engage pump at approximately 300 r.p.m. or 560 r.p.m. depending on pump model.
2. Turn suction SmartValve to "Rinsing tank" and pressure SmartValve to "Internal tank rinsing".

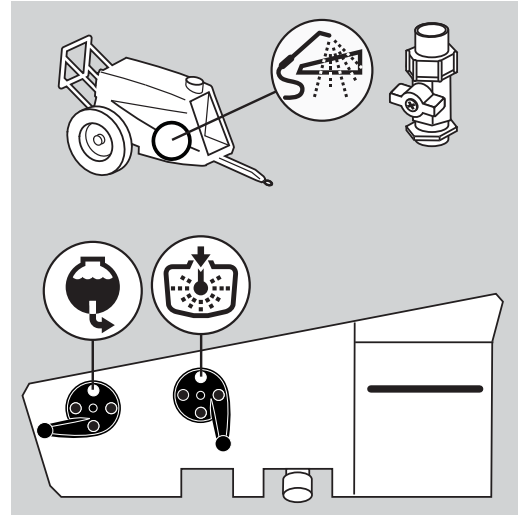

3. When enough water from the rinsing tank is transferred, turn suction SmartValve to "Main tank".
4. Turn pressure SmartValve to "Spraying" position and close the agitation valve. Adjust the pressure manually to approximately 145 psi (10 bar).

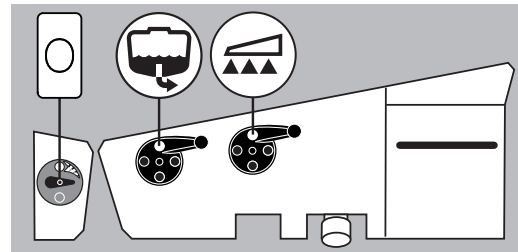

5. Open the ChemLocker cover. Cleaning wand is located in the holder at the frame (C).
6. Pull out the hose from the reel.
7. Turn the ball valve to position (A) to open.
8. Wash the sprayer with the cleaning wand.
9. Disengage the pump and close the ball valve again by turning it to position (B).
10. Retract the hose and place the cleaning wand in the holder (C).

i NOTE! Do not let go of the hose. Gently restrict the roll-in of the hose.

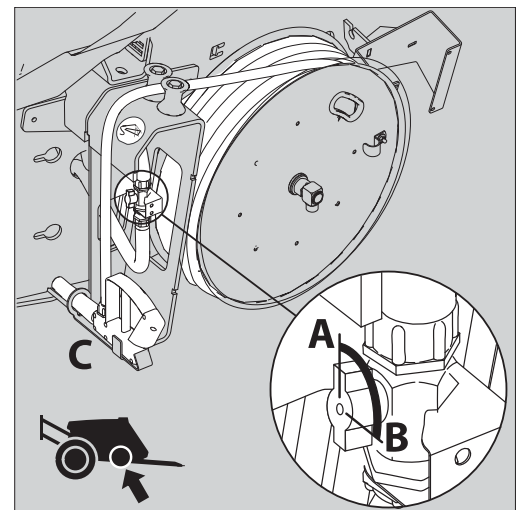

5 - Operation

C. Rinsing spraying circuit without diluting main tank content

This procedure is used to rinse the pump, operating unit, spray lines, etc. in case of stop in spraying before main tank is empty (e.g. beginning rain etc.).

Rinsing of the liquid system

1. Turn the suction SmartValve to "Rinsing tank". (Keep pressure SmartValve in "Spraying" position).



NOTE! The main ON/OFF on the Grip must be ON. Closing the main ON/OFF will transfer the rinse water back to the main tank!

2. Close agitation valve (no agitation).
3. Turn off the Cyclone Filter Boost Valve to avoid dilution of main tank content.
4. Engage the pump and spray water from rinsing tank in the field until all nozzle tubes/nozzles are flushed with clean water.
5. Disengage the pump again.



ATTENTION! It is advisable to increase the forward speed (double if possible) and reduce the pressure to 20 psi (1.5 bar) when spraying diluted remaining liquid in the field just sprayed.



ATTENTION! If a cleaning procedure is given on the chemical label, follow it closely.



ATTENTION! If the sprayer is cleaned with a high pressure cleaner lubrication of the entire machine is recommended.

D: Full internal cleaning (Soak wash)



NOTE! This cleaning procedure is always used when:

- The next crop to be sprayed is at risk to be damaged by the chemical just used, or
- The sprayer is not going to be used again for same chemical or crop right away, or
- Before any repair or maintenance job is going to be carried out on the sprayer.



NOTE! Wash of sprayer between jobs with incompatible crops must be done according to instructions from the chemical producer. Use e.g. AllClearExtra, as this is a commonly used cleaning agent. If your chemical prescribes another cleaning agent and/or another cleaning procedure, you must follow that.

Procedure for wash with a cleaning agent, e.g. AllClearExtra:

1. Rinse the sprayer in the field (See "A. Full internal rinsing" on page 58).
2. Drive to farm fill station.
3. Prepare sprayer for cleaning with cleaning agent, e.g. AllClearExtra. Fill water in the main tank to 10% of capacity (respectively 120 gal [450 liters], 160 gal [550 liters] and 200 gal [700 liters]). Fill the rinsing tank completely. This water is used later for rinsing.
4. Shut off all nozzles with the main ON/OFF button on the grip.
5. Turn suction SmartValve to "Main tank" and pressure SmartValve to "Spraying". Set agitation valve to "Full agitation".
6. Engage and set the pump at approximately 300 r.p.m. Engage auxiliary pump (FlexCapacity configurations only).
7. Allow the liquid in the main tank to circulate for at least 3 minutes with the nozzles shut to clean the return lines from boom to tank.
8. Close the agitation valve and turn the pressure SmartValve to "TurboFiller" for at least 10 seconds without activating the TurboFiller in order to burst and flush the safety valve.
9. Open the TurboFiller transfer valve and the deflector valve and allow liquid to circulate for 3 minutes.
10. Close the lid and activate the container rinsing valve to clean the hopper inside.
11. Shut off all three valves on the TurboFiller again.

12. Turn the pressure SmartValve to "Internal tank rinsing" and circulate liquid for another 3 minutes.
13. Spray out water with cleaning agent and chemical residue. Set the spray pressure at 45-75 psi (3-5 bar). Note that the washing water still contains active chemical and choose an appropriate area to spray out this. Alternatively the washings can be dumped at the Filling/washing location and retained in an appropriate receptacle (E.g. slurry tank or similar) - see section "Filling/washing location requirements". Spot contamination and accumulation must be avoided. Continue to spray until all liquid is expelled from the boom tubes and nozzles.
14. Shut off all nozzles by the main ON/OFF switch.
15. Rinse the sprayer again with clean water to rinse out any remaining cleaning agent. See "A. Full internal rinsing" on page 58. Any cleaning agent that remains in the fluid system could damage the next spray chemical filled into the main tank.
16. Include rinsing of the TurboFiller in steps 9 & 10 (above). Operate all 3 valves during this process.
17. Dismantle all filters (suction, pressure, in-line and nozzle filters) and clean the filter screens using clean water and detergent.



ATTENTION! The rinsing nozzles cannot always guarantee a 100% cleaning of the tank. Clean manually with a high pressure cleaner afterwards, especially if crops sensitive to the chemical just sprayed are going to be sprayed afterwards!



NOTE! It is the responsibility of the sprayer operator or owner that the sprayer is cleaned sufficiently to avoid contamination of the environment, crop damages and health & safety hazards to operator and the public. HARDI® cannot be held responsible for any damages or incidents related to insufficient cleaning.

Use of detergents

It is recommended to use an appropriate cleaning detergent suitable for cleaning agricultural sprayers.

- The cleaning detergents which contains a suitable lube or conditioner is recommended.
- If for some reasons this is not available and e.g. triple ammonia water is used, it is important to rinse the circuit immediately after and add some lubricant to the rinsing water to avoid e.g. ball valves seizing up.
- Use of automotive antifreeze/radiator coolant (ethylene glycol) will protect the valves, seals etc. from drying or seizing up.

Technical residue

Inevitably a quantity of spray liquid will remain in the system. It cannot be sprayed properly on the crop, as the pump takes in air when the tank is about to be empty.

This Technical Residue is defined as the remaining liquid quantity in the system as the first clear pressure drop on the pressure gauge is read. See "Technical residue" on page 83 for specific technical residues.

The residues in the tank should be diluted immediately in the relationship 1:10 with water and afterwards sprayed to the crop just sprayed with increased driving speed. It is to be noted, however, that the liquid in the spray lines (with original concentration) will be sprayed out first. Therefore there should be an untreated patch available to spray this out. In addition, the rinsing tank is to be used to separately rinse pump, linkage and armature.

5 - Operation

Using the drain valve

The drain valve is operated from platform just beside the main tank lid.

1. Pull the string to open the drain valve.
2. The valve is spring-loaded, but can be kept open by pulling the string upwards in the V-shaped slit.
3. To release, pull the string downward and the valve will close automatically.

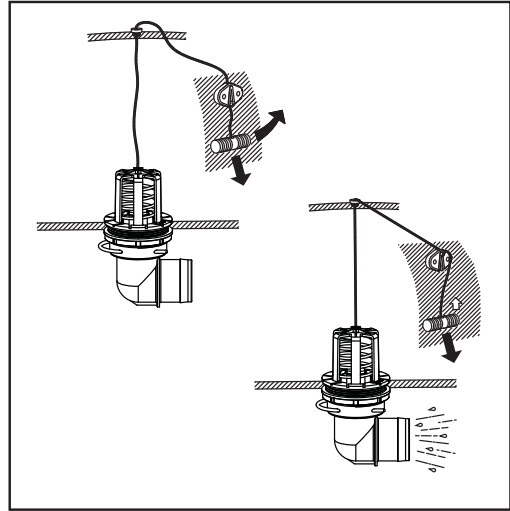

Lubrication

General info

Always store lubricants clean, dry and cool - preferably at a constant temperature - to avoid contamination from dirt and condensed water. Keep oil filling jugs, hoppers and grease guns clean, and clean the lubricating points thoroughly before lubricating. Avoid skin contact with oil products for longer periods.

Always follow the quantity recommendations. If no quantity is recommended, feed lubricator till new grease becomes visible.

Pictograms in lubrication & oiling plans designate the following:

1. Lubricant to be used (see "Recommended lubricants").
2. Recommended intervals (hours).

 **ATTENTION!** If the sprayer is cleaned with a high pressure cleaner, lubrication of the entire machine is recommended.

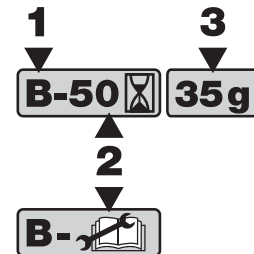

Recommended lubricants



BALL BEARINGS:

Universal Lithium grease, NLGI No. 2
SHELL RETINAX EP2
CASTROL LMX GREASE



SLIDE BEARINGS:

Lithium grease with Molybdenumdisulphide or graphite
SHELL RETINAX HDM2
CASTROL MOLYMAX



OIL LUB. POINTS:

TOTAL Transmission TM
SAE 80W/90
Castrol EPX 80W/90
SHELL Spirax 80W/90
Mobil Mobilube 80W/90



PUMPS:

Complex Lithium grease, NLGI No. 1
Viscosity @104°F (40° C) > 460 cSt
SHELL Gadus S3 V550L 1
Mobilgrease XHP 462
TOTAL Multis Complex SHD 460

Drawbar lubrication

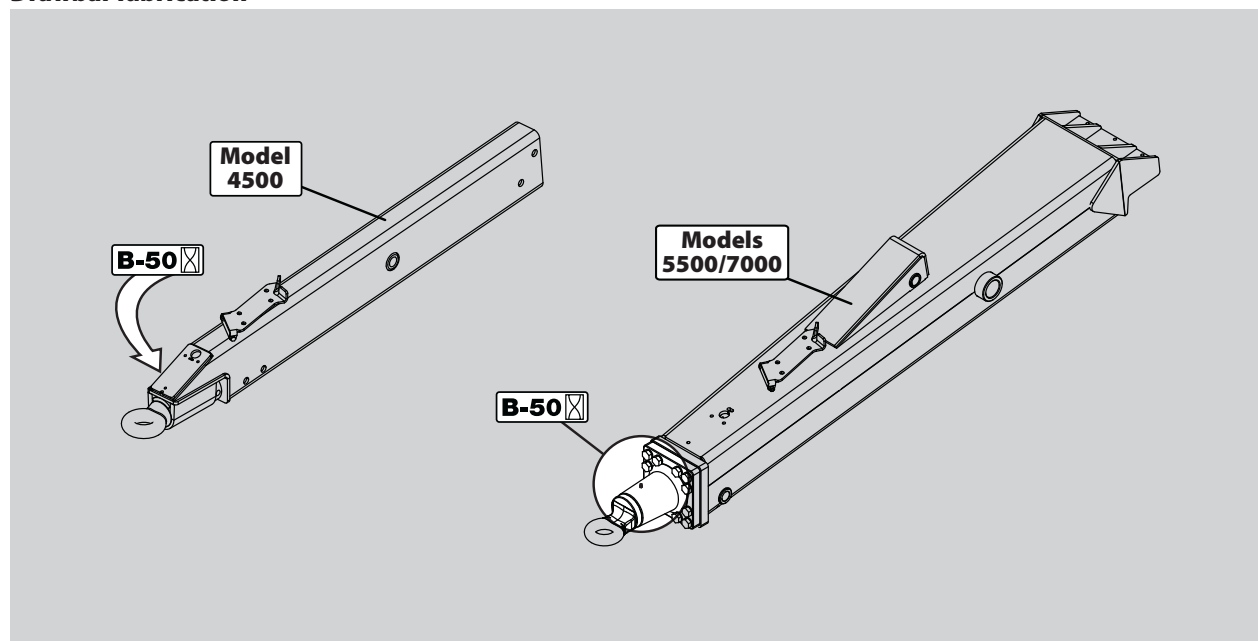

6 - Maintenance

Trailer/ParaLift lubrication & oiling plan

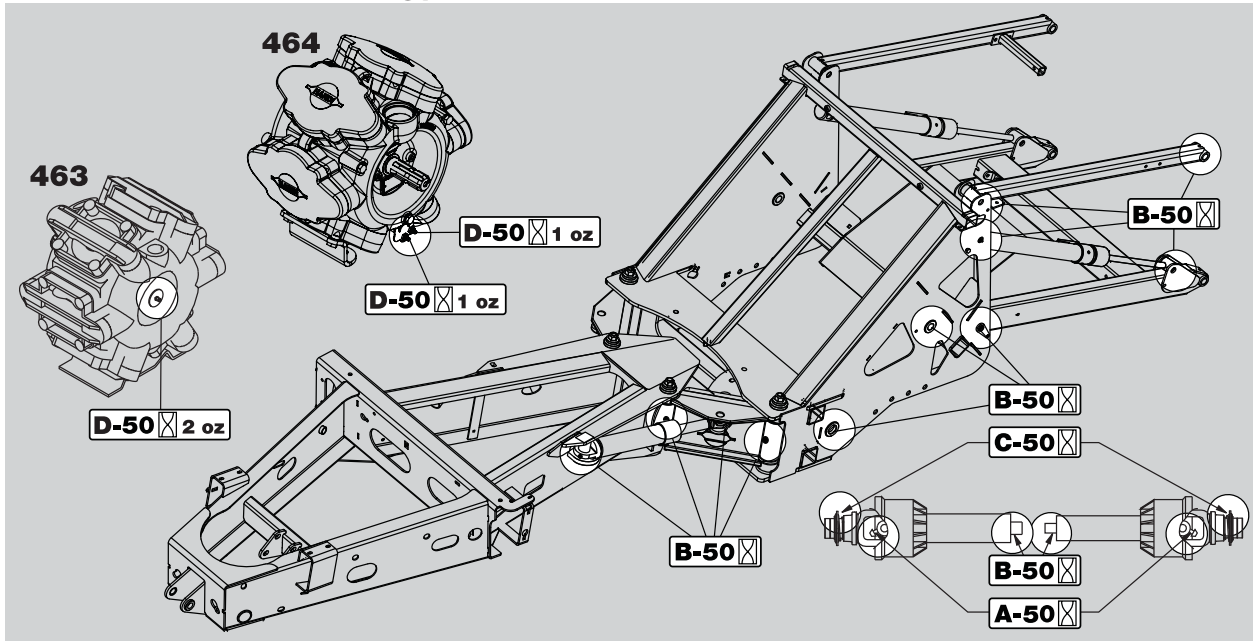

The lift is remote lubricated from the inside of the trailer's rear end.

1. Suspended axle attach point.
2. Suspension cylinder attach point.
3. Upper lift arm attach point.
4. Lift cylinder attach point.
5. Lower lift arm attach point.

i NOTE! Position 1 and 2 are for suspended sprayers only.

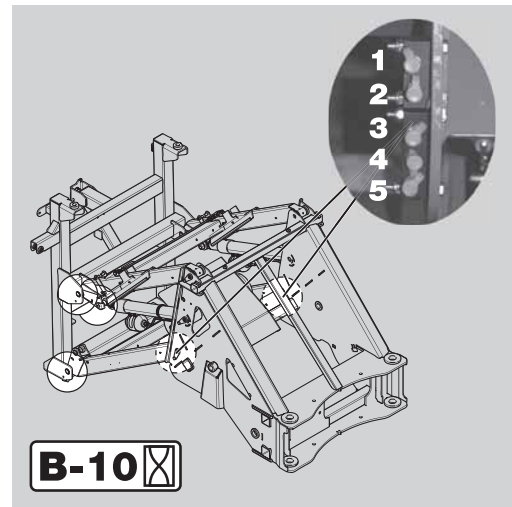

Service and maintenance intervals

10 hours service - Cyclone Filter

To service the Cyclone filter

1. Turn the pressure SmartValve to a function other than "Spraying".
2. Unscrew filter lid (A).
3. Lift the lid and filter (B) from housing.
4. Turn the two locks (C) outwards to unlock the filter from the lid.
5. Separate filter from the integrated filter guide in the lid and clean the filter.

To reassemble

1. Grease the two O-rings on the lid/filter guide. Due to small space at lid, use a brush or similar item to grease with.
2. Mount the filter onto the recess (do not grease) in the lid/filter guide.
3. Turn the two locks (C) inwards to lock the filter to the lid.
4. Place the filter/filter lid into housing and screw the lid until it hits the stop.

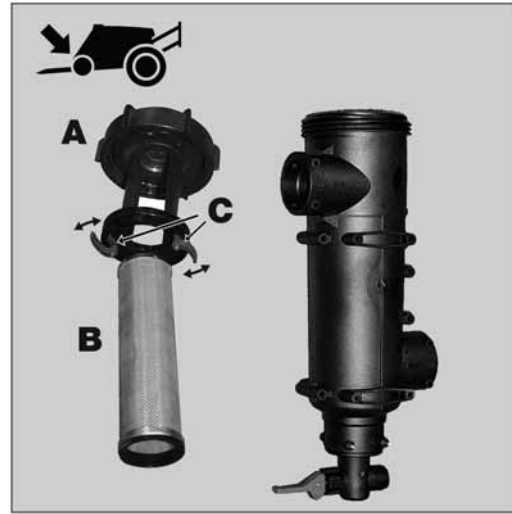

DANGER! The Cyclone Filter must not be opened when the pressure SmartValve is set to "Spraying". Otherwise, contaminated spray liquid can escape when opening the filter and drain the main tank contents!



WARNING! Always wear protective clothing and gloves before opening the filter!

10 hours service - EasyClean filter

This filter has a clogging indicator as mentioned in the "Description" chapter, but even if this indicator does not show clogging, it should be cleaned every 10 hours.

To service filter

1. Turn the filter lid counter clockwise to open.
2. Remove lid and filter from filter housing.
3. Separate filter element from lid/filter guide.
4. Clean filter and if necessary clean the housing for larger impurities.

To reassemble

1. Grease the O-ring on the filter lid.
2. Press the filter onto filter guide/lid and be sure it is fully seated into the guide.
3. Reassemble filter/filter lid into housing and be sure it is fully seated in the bottom of housing.
4. Turn filter lid clockwise to close lid.

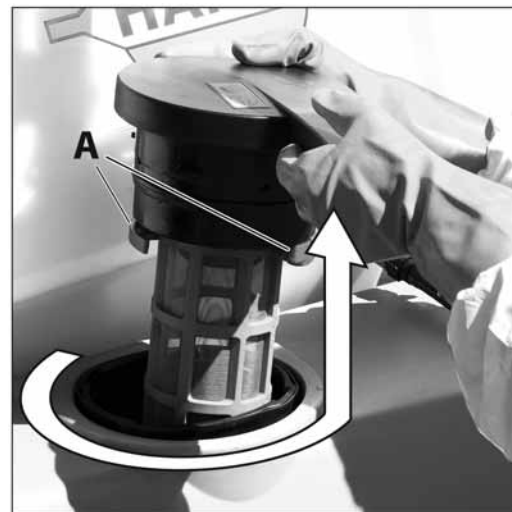

WARNING! Always wear protective clothing and gloves before opening the filter!



ATTENTION! If opening the filter becomes too difficult, or the filter housing needs to be drained, See "Emergency operation - EasyClean filter" on page 80.

6 - Maintenance

10 hours service -In-Line filter

If the boom is equipped with In-Line Filters, unscrew the filter bowl to inspect and clean the filter. When reassembling, the O-ring should be greased.

Alternative filter meshes are available. See "Filters and nozzles" on page 83.



WARNING! Be careful not to splash out liquid when unscrewing the filter bowl.



WARNING! Always wear protective clothing and gloves before opening the filter!

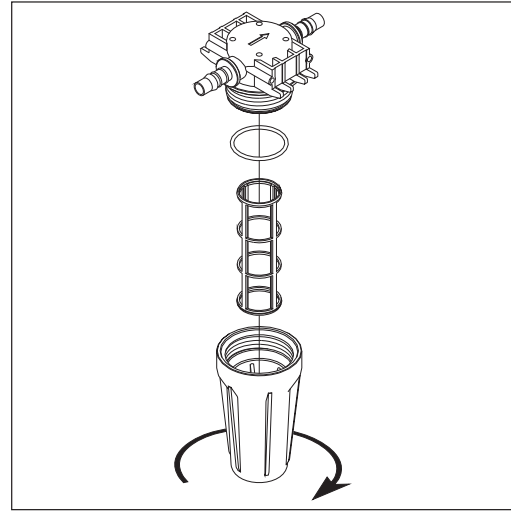

10 hours service - Nozzle filters

Check and clean.



10 hours service - Spraying circuit

Fill with clean water, operate all functions and check for leaks using higher spray pressure than normal. Check nozzle spray patterns visually using clean water.

50 hours service - Transmission shaft

Check function and condition of the transmission shaft protection guard. Replace any damaged parts.

50 hours service - Greasing the 464 pump

When operating the 464 pump, it MUST be greased every 50 hours with 1 oz. (30 grams) grease into each lubrication point.



ATTENTION! In order to avoid excessive wear, it is important to use a recommended lubricant (i.e. HARDI® part no. 28164600). See "Recommended lubricants" on page 63.



ATTENTION! The pump MUST be stopped during greasing!

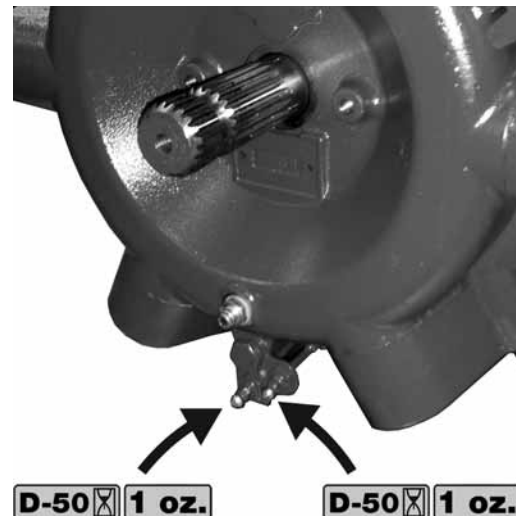

50 hours service - Wheel nuts

Tighten wheel nuts as follows with following torque wrench settings:

Wheel hub to rim plate: 250 Ft/lb (340 Nm)

Tightening sequence: See illustration and tighten in order of numbering.

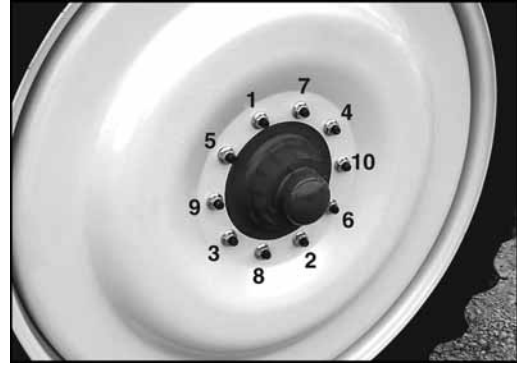

50 hours service - Tire pressure

Check the tire pressure according to the table in "Tire pressure" on page 84.



DANGER! Never inflate tires more than to the pressure specified in the table. Over-inflated tires can explode and cause severe personal injuries! See "Change of tire" on page 75.



WARNING! If replacing tires always use tires with min. load index as specified.

100 hours service - Check/tighten steering

If too much play is found in the steering section, it must be re-tightened. This applies to both steering and non-steering versions. Re-tighten the nuts on both sides to the specified torque.



NOTE! Specified torque is 185 Ft/lb (250 Nm).

Be sure that the split pin is fitted (or re-fitted if dismantled) at the end of the big bolts.

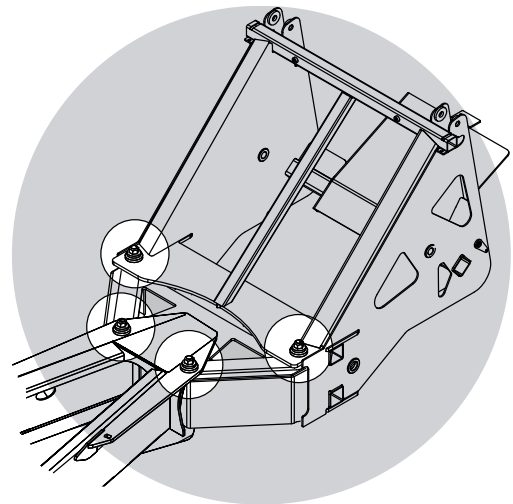

250 hours service - Readjustment of the boom

See boom Operator's manual

250 hours service - Hoses and tubes

Check all hoses and tubes for possible damage and proper attachment. Replace damaged hoses or tubes.

6 - Maintenance

250 hours service - Hydraulic circuit

Check the hydraulic circuit for leaks and repair if any. Refill Nitrogen accumulators for:

- ParaLift
- Yaw system (if fitted)
- Suspension (if fitted)



WARNING! Hoses for boom lifting device must be changed after every 5 years of use.



WARNING! Nitrogen accumulators may contain oil under pressure.

250 hours service - Wheel bearings

Check for play in the wheel bearings:

1. Place stop wedges in front of and behind LH wheel and jack up RH wheel.
2. Rock the RH wheel to discover possible play in the bearings.
3. If any play, support the wheel axle to prevent the trailer from falling down from the jack.
4. Remove hub cap (A) and cotter pin (B). Turn the wheel and tighten the castellated nut (C) until a slight resistance in the wheel rotation is felt.
5. Loosen the castle nut until the first notch - horizontal or vertical - is aligned with the cotter pin hole in the shaft.
6. Fit a new cotter pin and bend it.
7. Fill the hub cap with fresh grease and re-attach it onto the hub.
8. Repeat the procedure on LH wheel.

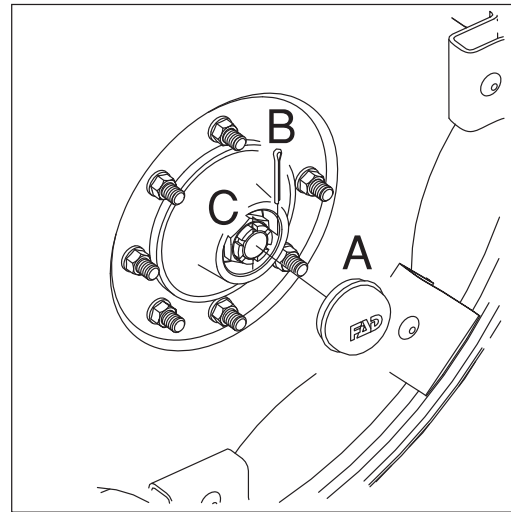

NOTE! Some hub caps are attached with screws. Make sure the seal is intact or replace if worn!

1000 hours service - Transmission shaft

Change the protection tube nylon bearings as described under "Shield replacement on transmission shaft".

1000 hours service - Wheel bearings

Check the condition of the bearings in the following way:

1. Place stop wedges in front of and behind LH wheel and jack up RH wheel.
2. Support the trailer with axle stands.
3. Remove the wheel.
4. Unscrew the 4 bolts and remove the hub cap (A), cotter pin (B) and castle nut (C).
5. Pull off the wheel hub assembly (D). Use a wheel puller if necessary.
6. Remove roller bearings (E), clean all parts in degreasing detergent and dry them. Inspect bearings (E) and replace if necessary.
7. Pack bearings (E) with fresh wheel bearing grease and re-install using a new seal (F).
8. Turn the wheel and tighten the castle nut (C) until a slight resistance in the wheel rotation is felt.
9. Loosen the castle nut until the first notch (horizontal or vertical) is aligned with the cotter pin hole on the shaft.
10. Fit a new cotter pin and bend it.
11. Fill the hub cap with fresh grease and re-attach it onto the hub.
12. Repeat the procedure on the LH wheel.

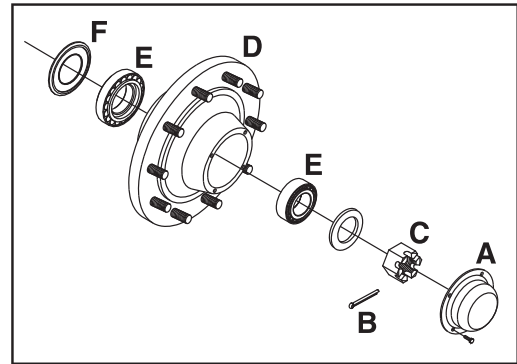

ATTENTION! The spindle has two holes available for the cotter pin. Use the one first aligned with the notch when loosening the castellated nut.



WARNING! If you do not feel totally confident changing wheel bearings, contact your HARDI® dealers workshop.

6 - Maintenance

Occasional maintenance

General info

The maintenance and replacement intervals for the following will depend very much on the conditions under which the sprayer will be operated and are therefore impossible to specify.

Model 464 pump valves and diaphragms replacement

Diaphragm pump overhaul kit (valves, seals, diaphragms etc.) can be ordered. Detect the pump model - kit can be ordered using correct HARDI® part No.:

Model 464: part No. 75586000

1. Lift off the plastic covers (C) with your hands (A) by pulling with the finger tips while pushing with the thumbs in the center, as shown in (B).

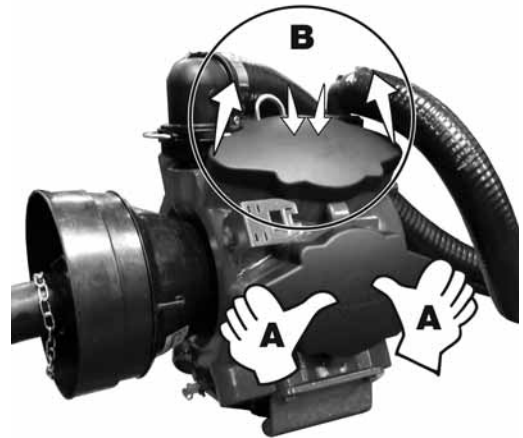

Valves

2. Loosen the 4 head bolts (1).
3. Remove the head (2).
4. Change the valves (3) - note their orientation so that they are replaced correctly!



ATTENTION! It is recommended to use new gaskets (4) when changing or checking valves.

Diaphragms

5. Loosen the diaphragm bolt (5).
6. Remove the diaphragm washer (6).
7. The diaphragm (7) may then be changed.
8. Check that the drain hole (8) at the bottom of the pump is not blocked.
9. Apply a small amount of pump grease on the underside of the diaphragms (between diaphragm and connecting rod washer).
10. Reassemble the pump with the following torque setting:
 - Diaphragm head bolts (1): 67 Ft/lb (90 Nm)
 - Diaphragm bolt (5): 67 Ft/lb (90 Nm)
 - Refit the plastic covers (C).



NOTE! The diaphragm bolt on 1000 r.p.m. pumps must be secured with a locking compound such as Loctite® 262 (HARDI® Part No.: 28045503).



ATTENTION! Before tightening the 4 bolts for the head (2), the diaphragm must be positioned between the center and top to ensure correct sealing between the diaphragm pump housing and diaphragm cover. Turn the crank shaft if necessary.

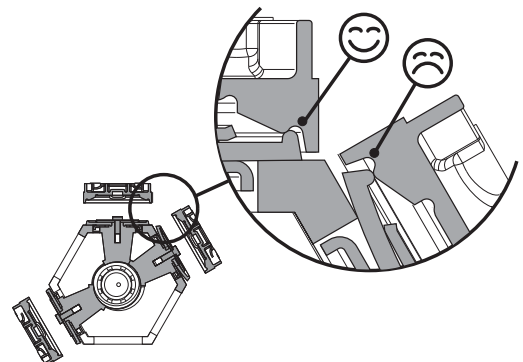
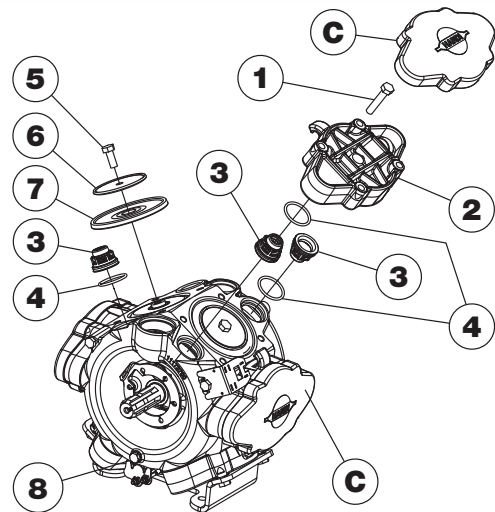

Re-lubrication after assembly

After disassembling the pump (diaphragm replacement, etc.), the pump **MUST** be lubricated with 7 oz. (200 grams) grease into each lubrication point.



ATTENTION! In order to avoid excessive wear, it is important to use a recommended lubricant (i.e. HARDI® part no. 28164600). See "Recommended lubricants" on page 63.

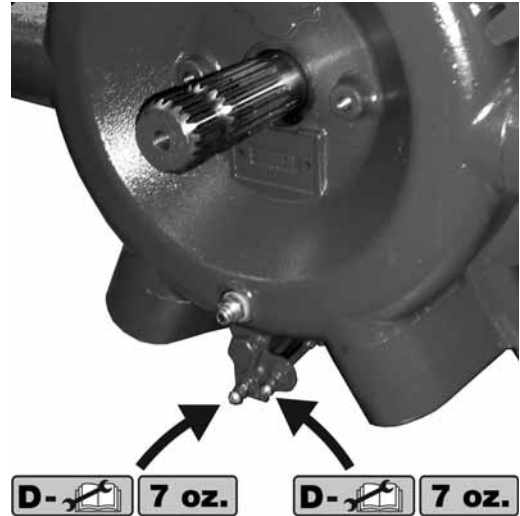

Model 463 pump valves and diaphragms replacement

Diaphragm pump overhaul kit (valves, seals, diaphragms etc.) can be ordered. Detect the pump model - kit can be ordered using correct HARDI® part No.:

Model 463: part No. 75073900

Valves

Remove valve cover (1) before changing the valves (2) - note their orientation so they are replaced correctly!



ATTENTION! A special valve with white flap (2A) is used at the two upper side inlets. It has to be placed in the valve openings as shown. All others are the type with black flap. It is recommended to use new gaskets (3) when changing or checking the valves.

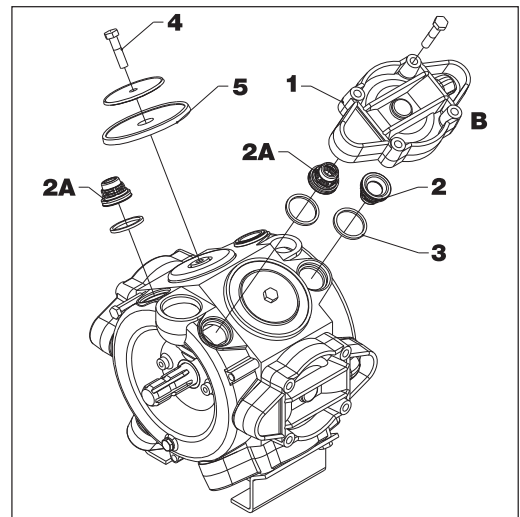

Diaphragms

Remove the diaphragm cover (4). The diaphragm (5) may then be changed. If fluids have reached the crankcase, re-grease the pump thoroughly. Also check that the drain hole at the bottom of the pump is not blocked. Reassemble with the following torque setting.

Reassemble pump model 463 with the following torque setting.

Diaphragm cover: 67 Ft/lb (90 Nm)

Diaphragm bolt: 67 Ft/lb (90 Nm)

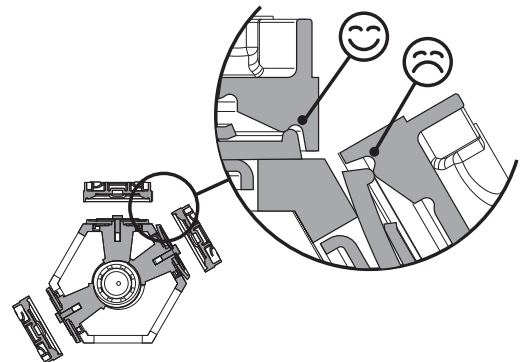

ATTENTION! Before tightening the 4 bolts for the diaphragm cover (B) the diaphragm must be positioned between center and top to ensure correct sealing between diaphragm pump housing and diaphragm cover. Turn crank shaft if necessary.

6 - Maintenance

Cone check/replacement for EFC distribution valve

Periodically check the distribution valves for proper sealing. Do this by running the sprayer with clean water and open all distribution valves. Cautiously remove the clip (A) and pull out the hose (B) for the return line. When the housing is drained, there should be no liquid flow through the return line. If there is any leakage, the valve cone (E) must be changed. Remove the clip (C) and lift the motor housing off the valve housing. Then unscrew the screw (D) and replace the valve cone (E). Reassemble in reverse order.

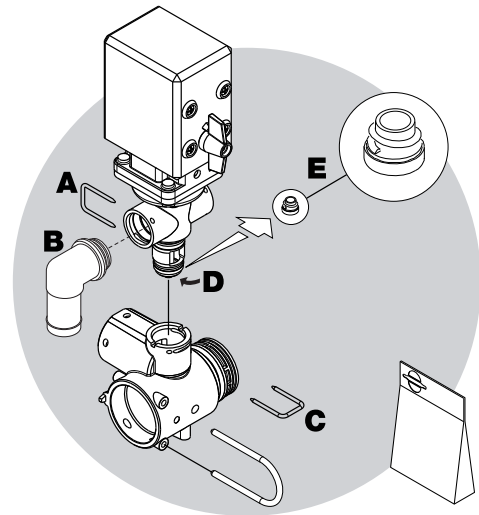

Level indicator adjustment

The level indicator reading should be checked regularly. When the tank is empty, the float should lie on the stop pin (D) of the rod, and the O-ring on the indicator should be positioned at the top position line (A).



ATTENTION! The wire guide wheels should be directed so they follow the direction of the wire.

If any deviation is found, do:

1. Pull out the plug (B).
2. Loosen screws (C).
3. Adjust the length of the cord until it reads correctly.
4. Push plug (B) back in place.



NOTE! For best accuracy adjustment shall be done with the sprayer attached to the tractor normally used.

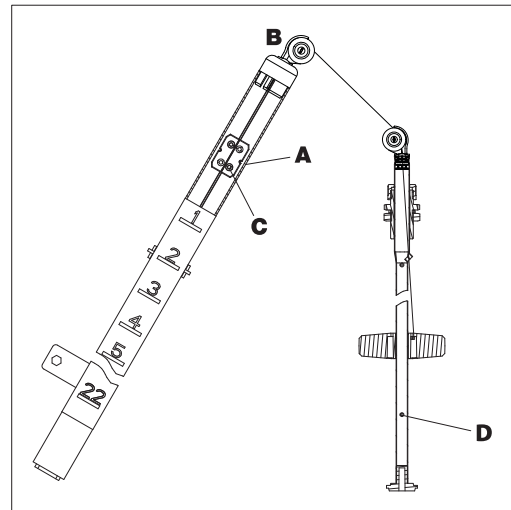

Level indicator wire replacement

If the wire on the level indicator has to be changed, the float guide pole is removed:

1. Remove the tank drain valve (see "Drain valve seal replacement" on page 73) and loosen the fitting holding the pole in position.
2. Pull the pole down through the drain valve hole till it is free in the top of the tank.
3. The pole can now be taken out of the tank through the filling hole.



DANGER! Do not enter the inside of the tank - the parts can be changed from the outside of the tank!

Drain valve seal replacement

If the main tank drain valve leaks, the seal and seat can be changed the following way.



DANGER! Do not enter the inside of the tank - the parts can be changed from the outside of the tank!



WARNING! Use eye / face protection mask when dismantling the tank drain valve!

1. Make sure the tank is empty and clean.
2. The valve must be closed and the string loose.
3. Pull out the clip (A) and pull down connecting piece (B). The entire valve assembly can now be pulled out.
4. Check cord and valve flap assembly (C) for wear, replace seal (D) and assemble again.
5. Assemble the valve assembly again using a new valve seat (E). Lubricate O-rings (F) before assembly.
6. Fit clip (A) again.

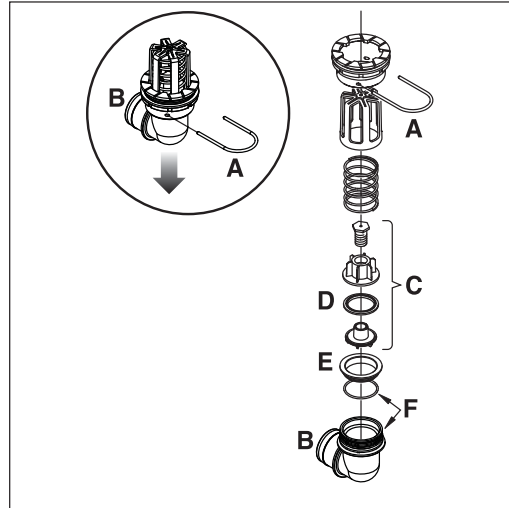

ATTENTION! Check function of valve with clean water before filling chemicals into the tank.

Adjustment of 3-way valve

The large ball valve (S93) used for SmartValves and valves for filling equipment can be adjusted if it is too tight to operate - or if it is too loose (=liquid leakage).

- Correct setting is when the valve can be operated smoothly by one hand.

Use a suitable tool and adjust the toothed ring inside the valve as shown on the drawing.



ATTENTION! The small ball valves (S67) cannot be adjusted.

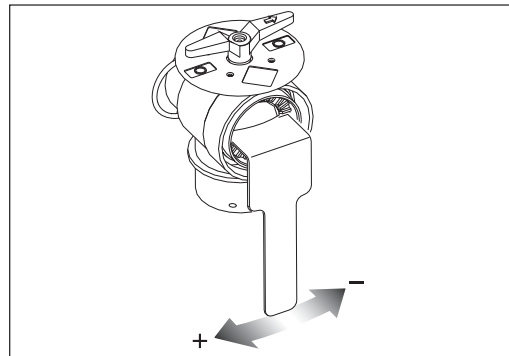

Safety valve activation

To make the fluid system work perfectly over time, it is good practice to regularly provoke opening of the safety valve.

This avoids clogging and ensures proper function of the safety valve. This is done by turning the pressure SmartValve to an unused function or ("TurboFiller" without activating it) when pump is running. This is good practice for all but particularly for sprayers without optional equipment.

6 - Maintenance

Readjustment boom - general info

Before beginning boom adjustments, please go through this check list:

1. The sprayer must be well lubricated (see part about lubrication).
2. Connect the sprayer to the tractor.
3. Place tractor and sprayer on level ground (horizontal).
4. Unfold boom.
5. Set tilt angle of both wings to horizontal position.

Adjustment of hydraulic cylinders are done without pressure in the system.



ATTENTION! See your Boom Operator's manual supplied with your sprayer for detailed technical information and service procedures specific to your boom configuration.



WARNING! Nobody is allowed to be under the boom while adjustment is carried out. Never walk under the boom unless it is safely folded and stowed on the transport brackets.

Wear bushing replacement on boom lift

Inspect and replace the wear bushings before they are worn through.

1. Connect the trailer to a tractor and unfold the booms to working position.
2. Lift the boom center frame with a lifting device and support it until the load is taken off the parallelogram arms.
3. Remove the screws (A), pull out the pins (B) at one of the upper parallelogram arms and replace the wear bushings.
4. Refit the arm.
5. Repeat this procedure for the other upper arm.
6. The lower arms must be disconnected simultaneously.
7. Grease all grease nipples.
8. Remove the lifting gear.

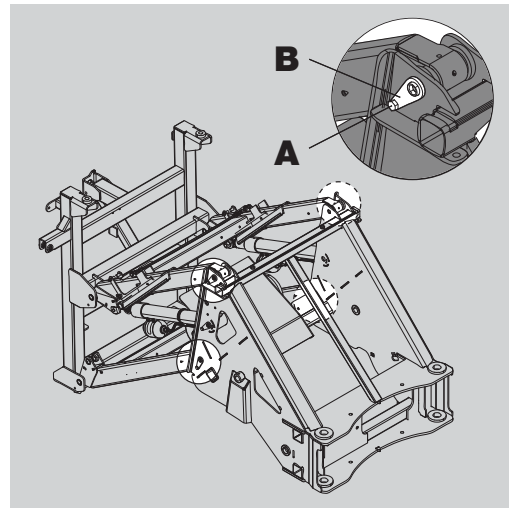

Change of bulbs

1. Switch off the light.
2. Loosen the screws on the lamp and remove the cover or lens.
3. Remove the bulb.
4. Fit a new bulb, refit the cover and tighten the screws.



ATTENTION! If halogen bulbs are used, never touch the bulb with your fingers. Natural moisture in the skin will cause the bulb to burn out when the light is switched on. Always use a clean cloth or tissue when handling halogen bulbs.

Wear bushing replacement on steering

If too much play is found in the steering, the wear bushings must be replaced. This should be done at your local HARDI® dealer.

Shield replacement on transmission shaft

See the manufacturer's instruction book.

Replacement of transmission shaft cross journals

See the manufacturer's instruction book.

Change of tire

If necessary to replace tires, it is recommended to leave this to a specialist and follow the mentioned rules.

- Always clean and inspect the rim before mounting.
- Always check that the rim diameter corresponds exactly to the rim diameter molded on the tire.
- Always inspect inside of the tire for cuts, penetrating objects or other damages. Repairable damages should be repaired before installing the tube. Tires with non-repairable damages must never be used.
- Also inspect inside of the tire for dirt or foreign bodies and remove it before installing the tube.
- Always use tubes of recommended size and in good condition. When fitting new tires always fit new tubes.
- Before mounting, always lubricate both tire beads and rim flange with approved lubricating agent or equivalent anti-corrosion lubricant. Never use petroleum based greases and oils because they may damage the tire. Using the appropriate lubricant the tire will never slip on the rim.
- Always use specialized tools as recommended by the tire supplier for mounting the tires.
- Make sure that the tire is centered and the beads are perfectly seated on the rim. Otherwise danger of bead wire tear can occur.
- Inflate the tire to 14.5-19 p.s.i. (100-130 kPa) then check whether both beads are seated perfectly on the rim. If any of the beads do not seat correctly, deflate the assembly and re-center the beads before starting inflation of the tire. If the beads are seated correctly on the rim at 14.5-19 p.s.i. inflate the tire to a maximum of 36 p.s.i. (250 kPa) until they seat perfectly on the rim.
- Never exceed the maximum mounting pressure molded on the tire!
- After mounting tires adjust inflation pressure to operation pressure recommended by the tire manufacturer.
- Do not use tubes in tubeless tires.



DANGER! Non observance of mounting instructions will result in the bad seating of the tire on the rim and could cause the tire to burst leading to serious injury or death!



DANGER! Never mount or use damaged tires or rims! Use of damaged, ruptured, distorted, welded or brazed rim is not allowed!

6 - Maintenance

Off-season storage

Off-season storage program

To preserve the sprayer and protect the components, carry out following off-season storage program.

Before storage

When the spraying season is over, you should devote some extra time to the sprayer. If chemical residue is left over in the sprayer for longer periods, it may reduce the life of the individual components.

1. Clean the sprayer completely - inside and outside - as described under "Cleaning" on page 56. Make sure that all valves, hoses and auxiliary equipment have been cleaned with detergent and flushed with clean water afterwards, so that no chemical residue is left in the sprayer.
2. Replace any damaged seals and repair any leaks.
3. Empty the sprayer completely and let the pump work for a few minutes. Operate all valves and handles to drain as much water from the spraying circuit as possible. Let the pump run until air comes out of all nozzles. Remember to drain the rinsing tank also.
4. Pour approximately 13 gal. (50 liters) anti-freeze into the main tank. This will mix with the remaining water in the fluid system to create a protective ratio of anti-freeze/water solution.
5. Engage the pump and operate all valves and functions, operating unit, chemical inductor etc. allowing the anti-freeze mixture to be distributed around the entire circuit. Open the operating unit main ON/OFF valve and distribution valves so that the anti-freeze is sprayed through the nozzles as well. The anti-freeze will also prevent O-rings, seals, diaphragms etc. from drying out. On sprayers with FlexCapacity pump, this must also be engaged and flushed.
6. Lubricate all lubricating points according to the lubricating scheme - regardless of intervals stated.
7. When the sprayer is dry, remove rust from scratches or damages in the paint, if any, and touch up the paint.
8. Remove the glycerine-filled pressure gauges and store them frost-free in vertical position.
9. Apply a thin layer of anti-corrosion oil (e.g. SHELL ENSIS FLUID, CASTROL RUSTILO or similar) on all metal parts. Avoid oil on rubber parts, hoses and tires.
10. Fold the boom in transport position and relieve pressure from all hydraulic functions.
11. All electric plugs and sockets are to be stored in a dry plastic bag to protect them against damp, dirt and corrosion.
12. Remove the control boxes and computer display from the tractor, and store them dry and clean (inside). A non-condensing environment is recommended.
13. Wipe hydraulic snap-couplers clean and fit the dust caps.
14. Apply grease on all hydraulic ram piston rods which are not fully retracted in the barrel to protect against corrosion.
15. Chock up the wheels, to prevent moisture damage and deformation of the tires. Tire blacking can be applied to the tire walls to preserve the rubber.
16. To protect against dust, the sprayer can be covered by a tarpaulin. Ensure ventilation to prevent condensation.

Preparing the sprayer for use after storage.

After a storage period, the sprayer should be prepared for the next season the following way:

1. Remove the cover.
2. Remove the support from the wheel axle and adjust tire pressure.
3. Wipe off the grease from hydraulic ram piston rods.
4. Fit the pressure gauges again. Seal with Teflon tape.
5. Connect the sprayer to the tractor including hydraulics and electrics.
6. Check all hydraulic and electric functions.
7. Empty the tank of remaining anti-freeze.
8. Rinse the entire liquid circuit of the sprayer with clean water.
9. Fill with clean water and check all functions.

Operational problems

General info

Operational incidents are frequently due to the same reasons:

1. A suction leakage reduces the pump pressure and may interrupt suction completely.
2. A clogged suction filter may damage suction or interrupt and prevent the pump from running normally.
3. A clogged pressure filter increases pressure in the fluid system in front of the pressure filter. This may blow the safety valve.
4. Clogged In-line or nozzle filters increase pressure in the pressure gauge but decrease pressure at the nozzles.
5. Impurities sucked by the pump may prevent the valves from closing correctly, thus reducing the pump flow.
6. A bad reassembly of the pump elements, especially the diaphragm covers, causes air intakes or leaks and reduces the pump flow.
7. Rusted or dirty hydraulic components cause bad connections and early wears.
8. A badly charged or faulty battery causes failures and misbehavior in the electrical system.

Therefore ALWAYS check

1. Suction and pressure filters, as well as nozzles, are clean.
2. Hoses for leaks and cracks, paying particular attention to suction hoses.
3. Gaskets and O-rings are present and in good condition.
4. Pressure gauge is in good working order. Dosage accuracy depends on it.
5. Operating unit functions properly. Use clean water to check.
6. Hydraulic components are clean.
7. The good condition of the tractor battery and its connectors.

7 - Fault finding

Liquid system

FAULT	PROBABLE CAUSE	CONTROL/REMEDY
No spray from boom when turned on.	SmartValve positions wrong. Suction/pressure filters clogged. No suction from tank.	Set correct valve positions for spraying. Clean suction and pressure filters. See if suction fitting in main tank sump is free of sedimentation.
Lack of pressure.	Incorrect assembly. Air in system. Too much agitation. Pump valves blocked or worn. Blocked filters Defect pressure gauge.	Boost valve is open. Fill suction hose with water for initial prime. Close the agitation valve. Check for obstructions and wear. Replace if necessary. Clean all filters. Check for dirt at inlet of gauge.
Pressure dropping.	Filters clogging. Nozzles worn. Sucking air towards end of tank load.	Clean all filters. Fill with cleaner water. If using powders, make sure agitation is on. Check flow rate and replace nozzles if it exceeds 10%. Lower pump r.p.m.
Pressure increasing.	Pressure filters beginning to clog.	Clean all filters.
Formation of foam.	Air is being sucked into system. Excessive liquid agitation.	Check tightness/gaskets/O-rings of all fittings on suction side. Reduce pump r.p.m. Check safety valve is tight. Ensure returns inside tank are present. Use foam damping additive.
Liquid leaks from bottom of pump.	Damaged diaphragm.	Replace. See changing of valves and diaphragms.
Grease leaks from the bottom of the pump.	Grease used has too low viscosity.	Change to recommended grease type.
Grease leaks from the shaft grease seals.	Grease used has too low viscosity. Bearings worn/too high friction.	Change to recommended grease type Replace pump bearings and grease seals.
Vibrations in system and unpleasant noise from pump.	Air is being sucked into system. Pump valves are blocked or worn.	Check for leaks, holes in hoses, tightness/gaskets/O-rings of all fittings on suction side. Check for obstructions and wear. Replace if necessary.
Lack of flow/capacity.	Internal wear on connecting rod and ring. Pump valves are blocked or worn.	Poor greasing. Replace parts as needed and observe proper grease quality and intervals. Check for obstructions and wear. Replace if necessary.
Extreme internal erosion on diaphragm covers and housing.	Too high vacuum caused by plugged suction filter or excessive pump r.p.m. Lack of internal cleaning. Lack of conservation of the fluid system during storage.	Replace affected pump parts. Clean suction filter and observe max. pump r.p.m. Use recommended cleaning procedures and add extra cleaning agents. Always use a proper mixture of antifreeze during storage.
Short diaphragm life.	Over speeding of the pump.	Observe max. pump r.p.m.
Operating unit not functioning or having malfunction.	Blown fuse(s). Wrong polarity. Valves not closing properly. No power.	Check mechanical function of microswitches. Use cleaning/lubricating agent if the switch does not operate freely. Check motor. 450-500 milli-Amperes max. Change motor, if over. Brown to positive (+). Blue to negative (-). Check valve seals for obstructions. Check microswitch plate position. Loosen screws holding plate a 1/2 turn. Wrong polarity. Check that brown is pos. (+), Blue is neg. (-). Check print plate for dry solders or loose connections. Check fuse holder is tight around fuse.

Hydraulic system - Z model

FAULT	PROBABLE CAUSE	CONTROL/REMEDY
No boom movements when activated.	Insufficient hydraulic pressure.	Check oil pressure.
	Insufficient oil supply.	Check tractor hydraulic oil level. Oil flow must be min. 2550 l/min. and max. 130 l/min. Check tractor hydraulic oil level.
	Blown fuse(s).	Check / replace fuse in junction box.
	Bad / corroded electrical connections.	Check / clean connections, multi plugs etc.
	Insufficient power supply.	Voltage on activated solenoid valve must be more than 8 volts. Use wires of at least 4 mm for power supply.
	Defect relay / diodes in junction box.	Check relays, diodes and soldering at PCB in junction box. LED diodes indicate boom functions.
	Clogged restrictors in bypass block.	Remove and clean restrictors in bypass block (See hydraulic diagram). Change hydraulic oil + filter.
Paralift lock does not lock. Boom lift raises to max. position when tractor hydraulics are engaged.	Wrong polarity.	Check polarity. Red positive (+) Black negative (-).
	Back pressure in return line exceeds 15 bar.	Connect the return line with free flow to hydraulic oil reservoir. Divide return line in two and lead return oil back to reservoir via two spool valves.
Oil heats up in Closed Center systems.	Bypass valve does not close properly.	Check / close (screw in) by-pass valve.
	Internal leaks in flow regulator.	Replace flow regulator O-rings and backup rings. Replace flow regulator.
Individual ram does not move.	Clogged restrictor.	Dismantle and clean restrictor.

7 - Fault finding

Mechanical problems

Emergency operation - Liquid system

In case of power failure it is possible to operate all functions of the operating unit manually. First disconnect the multi-plug from the control box. Now manually turn the emergency control knobs.

The problem may be due to a blown fuse. A fuse is placed inside the box. Fuse type: Thermo

Emergency operation - EasyClean filter

If difficulties occur with opening the filter and closing the built-in valve, use a 13 mm wrench on the key profile (A).

Also the filter can be drained before filter element at the drain plug (B).



WARNING! Always wear protective clothing and gloves before opening the filter!



8 - Technical specifications

Dimensions

General info

All measures, values and weights are depending on mounted options and specific adjustments.

Overall dimensions

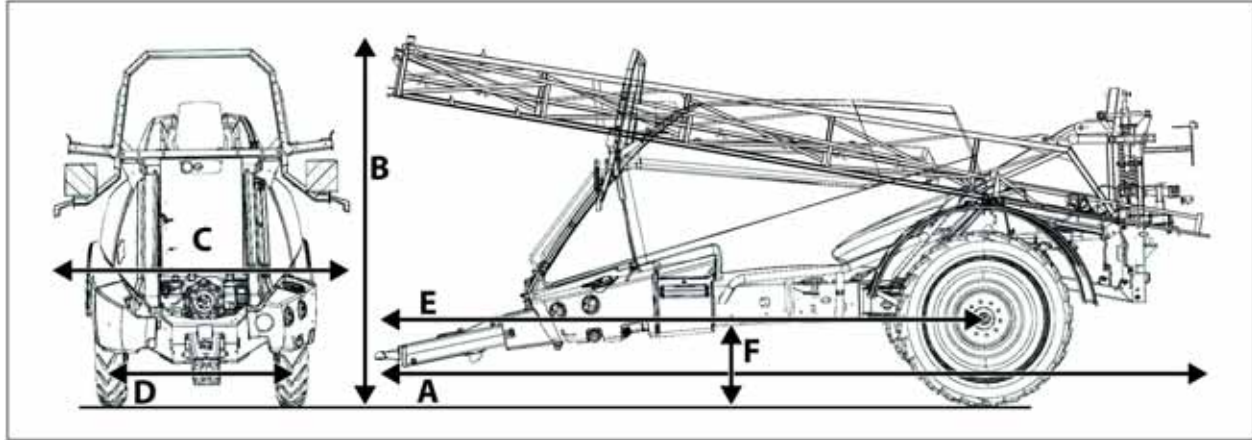

	A	B	C1*	C2**	D	E	F
4500	25'7"	11'10"	11'6"	N/A	60° to 90°	17'5"	31"
5500	28'3"	11'10"	11'6"	11'6"	60° to 90°	17'5"	31"
7000	28'3"	12'0"	11'6"	11'6"	60° to 90°	19'10"	31"

All measurements are in feet and inches

*Force™ boom

**Terra Force boom

Weight

4500 with Force™ boom

Boom Width	Empty tank					Full tank*				
	Folded in transport		Unfolded		Total Weight	Folded in transport		Unfolded		Total Weight
	Axle load	Hitch load	Axle load	Hitch load		Axle load	Hitch load	Axle load	Hitch load	
80 ft.	9243	2017	10536	724	11260	17207	5057	18500	3764	22264
90 ft.	9321	2039	10663	697	11360	17285	5059	18627	3737	22364
100 ft.	9493	2079	10901	671	11572	17457	5119	18865	3711	22576
120 ft.	9831	2137	11410	558	11968	17795	5177	19374	3598	22972
132 ft.	10113	2185	11770	528	12298	18077	5225	19734	3568	23302

All weights in pounds (lbs)

*Main tank capacity: 1200 gal (4542 L), Rinse tank capacity: 122 gal (460 L), filled with water

5500 with Force™ boom

Boom Width	Empty tank					Full tank*				
	Folded in transport		Unfolded		Total Weight	Folded in transport		Unfolded		Total Weight
	Axle load	Hitch load	Axle load	Hitch load		Axle load	Hitch load	Axle load	Hitch load	
80 ft.	10504	2230	11702	1032	12734	20558	6511	21756	5313	27069
90 ft.	10582	2252	11829	1006	12834	20636	6533	21883	5287	27170
100 ft.	10754	2292	12067	979	13046	20808	6573	22121	5260	27381
120 ft.	11092	2350	12575	867	13442	21146	6631	22629	5148	27777
132 ft.	11374	2398	12936	836	13772	21428	6679	22990	5117	28107

All weights in pounds (lbs)

*Main tank capacity: 1600 gal (6056 L), Rinse tank capacity: 122 gal (460 L), filled with water

8 - Technical specifications

Weight (cont.)

5500 with Terra Force boom

Boom Width	Empty tank					Full tank*				
	Folded in transport		Unfolded		Total Weight	Folded in transport		Unfolded		Total Weight
	Axle load	Hitch load	Axle load	Hitch load		Axle load	Hitch load	Axle load	Hitch load	
120 ft.	12503	3007	14719	791	15510	22557	7288	24773	5072	29845
132 ft.	12569	3099	14911	758	15669	22623	7380	24965	5039	30004

All weights in pounds (lbs)

*Main tank capacity: 1600 gal (6056 L), Rinse tank capacity: 122 gal (460 L), filled with water

7000 with Force™ boom

Boom Width	Empty tank					Full tank*				
	Folded in transport		Unfolded		Total Weight	Folded in transport		Unfolded		Total Weight
	Axle load	Hitch load	Axle load	Hitch load		Axle load	Hitch load	Axle load	Hitch load	
80 ft.	10614	2340	11812	1142	12954	23308	7312	24506	6114	30620
90 ft.	10692	2362	11939	1116	13054	23386	7334	24633	6088	30721
100 ft.	10864	2402	12177	1089	13266	23558	7374	24871	6061	30932
120 ft.	11202	2460	12685	977	13662	23896	7432	25379	5949	31328
132 ft.	11484	2508	13046	946	13992	24178	7480	25740	5918	31658

All weights in pounds (lbs)

*Main tank capacity: 2000 gal (7570 L), Rinse tank capacity: 122 gal (460 L), filled with water

7000 with Terra Force boom

Boom Width	Empty tank					Full tank*				
	Folded in transport		Unfolded		Total Weight	Folded in transport		Unfolded		Total Weight
	Axle load	Hitch load	Axle load	Hitch load		Axle load	Hitch load	Axle load	Hitch load	
120 ft.	12613	3117	14829	901	15730	25307	8089	27523	5873	33396
132 ft.	12679	3209	15021	868	15888	25373	8181	27715	5840	33555

All weights in pounds (lbs)

*Main tank capacity: 2000 gal (7570 L), Rinse tank capacity: 122 gal (460 L), filled with water

Wheel and axle dimensions

Wheel	Adj. axle	Fixed axle	Duals 22" row	Duals 30" row	Clearance*
320/90 R50	60" - 90"	120"	88"/132"	60"/90"	30.3"
480/80 R46	60" - 90"	120"	88"/132"	60"/90"	32.2"
380/105 R50	60" - 90"	120"	88"/132"	60"/90"	33.5"
480/80 R50	60" - 90"	120"	88"/132"	60"/90"	34.5"

*under axle

8 - Technical specifications

Specifications

Diaphragm pumps

Pump model 464/12.0 (463/12.0)	PSI	RPM	GPM	HP
	0	540	85.0	3.0
	29	540	83.7	4.2
	58	540	82.9	5.6
	88	540	81.3	6.9
	147	540	79.7	9.5
	220	540	77.9	9.9

Pump model 464/6.5 (463/6.5)	PSI	RPM	GPM	HP
	0	1000	91.9	4.3
	29	1000	84.8	5.4
	58	1000	82.7	6.8
	88	1000	81.4	8.3
	147	1000	78.2	11.0
	220	1000	75.5	13.8

Technical residue

Worst case technical residue with largest tank, largest fluid system and boom. Narrower booms and fluid systems with less options will have less residues than stated below.

Sprayer combination	Dilutable volume - Tank and fluid system	Non-dilutable volume - Boom	Total residual volume
2000 Gallons, 132' TERRA FORCE, FlexCapacity and 9 sections.	13 gallons	18 gallons	31 gallons

Filters and nozzles

Possible options:

Mesh	Filter gauze width	EasyClean	Cyclone	In-line**
30	0.58 mm	Yes	-	-
50	0.30 mm	Yes, standard	-	Yes
80	0.18 mm	Yes	Yes, standard	Yes, standard
100	0.15 mm	-	-	Yes

8 - Technical specifications

Power consumption

Recommended tractor engine power output are as follows.

Sprayer model	Hp	kW
4500 (not TERRA FORCE)	115	86
5500	130	95
7000	150	110

Tire pressure

The following charts list the recommended tire pressure by model and tire size. Tire pressure may need to be adjusted depending on the actual machine weight, tire brand, or conditions.

Single tires	Tire size						
	Sprayer model	320/90 R50 ¹	320/90 R50 ²	380/90 R46	480/80 R46	380/105 R50	480/80 R50
4500		52 psi (3.6 bar)	60 psi (4.1 bar)	60 psi (4.1 bar)	40 psi (2.8 bar)	40 psi (2.8 bar)	40 psi (2.8 bar)
5500		52 psi (3.6 bar)	70 psi (4.8 bar)	70 psi (4.8 bar)	52 psi (3.6 bar)	50 psi (3.4 bar)	50 psi (3.4 bar)
7000		N/A as singles	N/A as singles	N/A	N/A	60 psi (4.1 bar)	60 psi (4.1 bar)

1 - Load Index: 161

2 - Load Index: 169

Duals	Tire size
Sprayer model	320/90 R50
4500	30 psi (2.1 bar)
5500	35 psi (2.4 bar)
7000	40 psi (2.8 bar)



DANGER! Never inflate tires more than to the pressure specified on the tire. Over-inflated tires can explode and cause severe personal injuries! See "Change of tire" on page 75.

Materials and recycling

Disposal of the sprayer

When the equipment has completed its working life, it must be thoroughly cleaned. The tank, hose and synthetic fittings can be incinerated at an authorized disposal plant. The metallic parts can be scrapped. Always follow local legislation regarding disposal.

Materials used:

Tanks:	HDPE
Frame etc.:	Steel
Pump:	Cast iron
Diaphragms:	PUR
Hoses (suction):	PVC
Hoses (pressure):	EPDM
Valves:	Glass reinforced PA
Filters:	PP
Nozzles:	Unfilled POM
Fittings:	Glass reinforced PA

8 - Technical specifications

Electrical connections

Rear lights

The wiring is in accordance with ANSI/ASAE S279.11.

Position	Wire color
1. Ground	White
2. Work lamps	Black
3. LH flashing & turn indicator	Yellow
4. Free	Red
5. RH flashing & turn indicator	Green
6. Free	Brown
7. Free	Blue

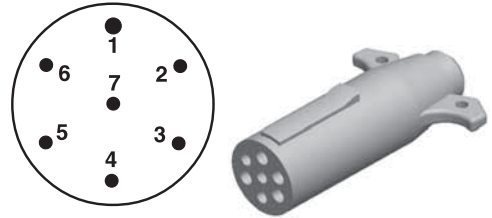

Electrical specifications for boom and work light

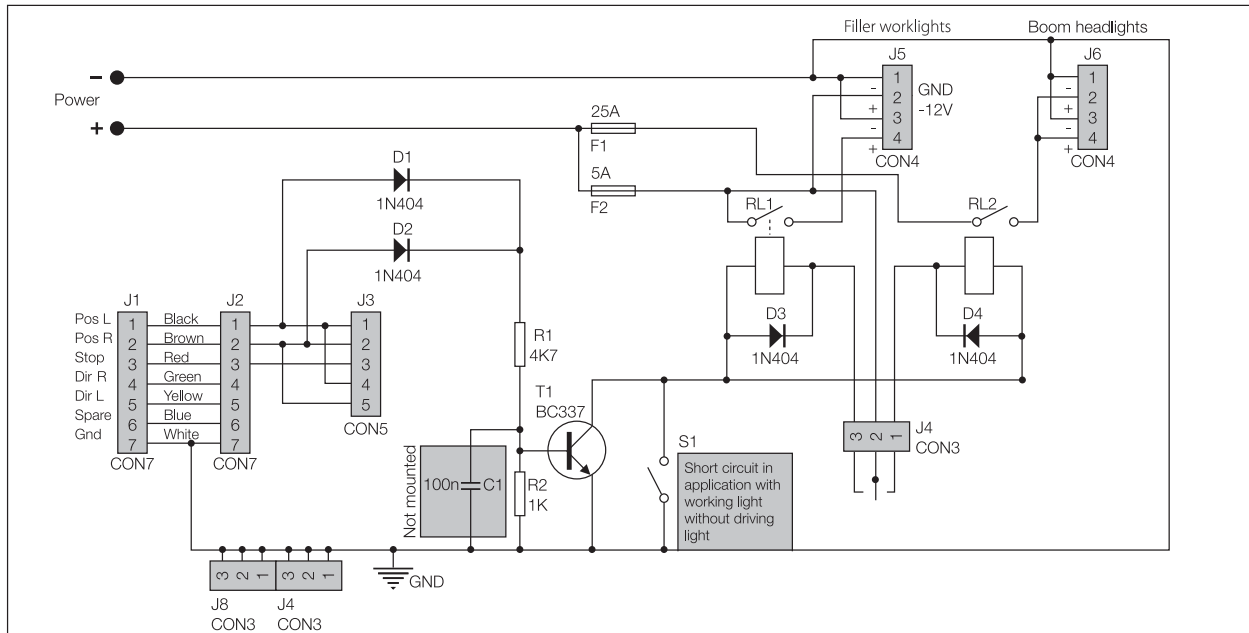

8 - Technical specifications

EFC

The EFC operating unit fulfills the EC noise reduction standards.

When connecting an optional function, be aware that maximum current for every connector is 2 Amp. Total current for the whole connector box may not exceed 10 Amp.

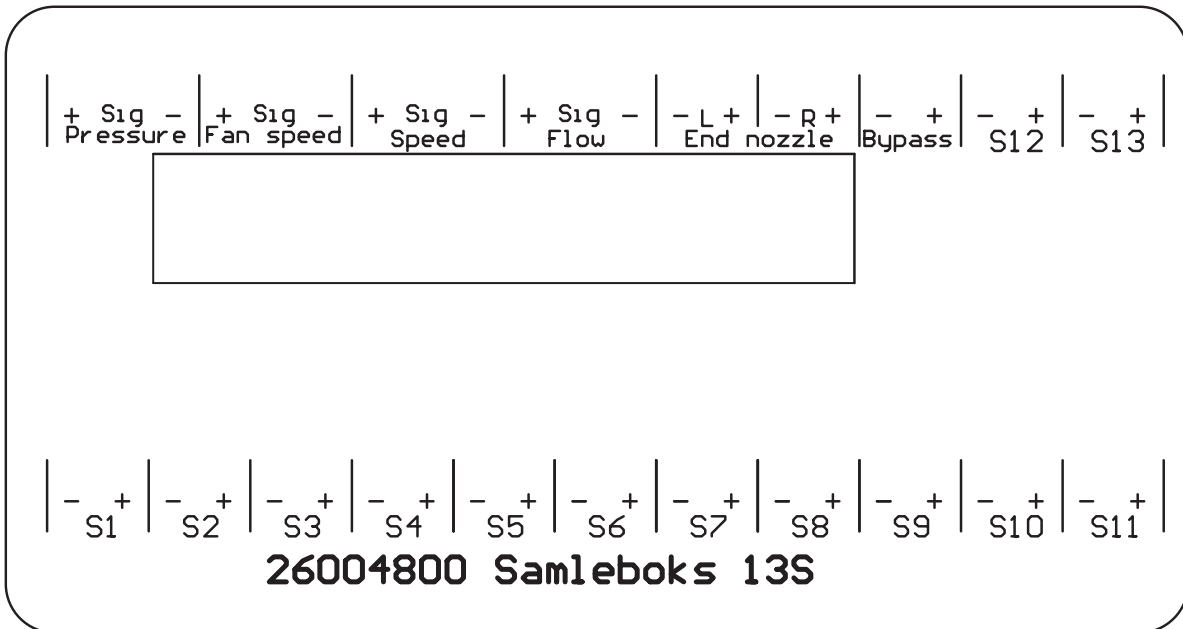

8 - Technical specifications

Charts

Sprayer hydraulics

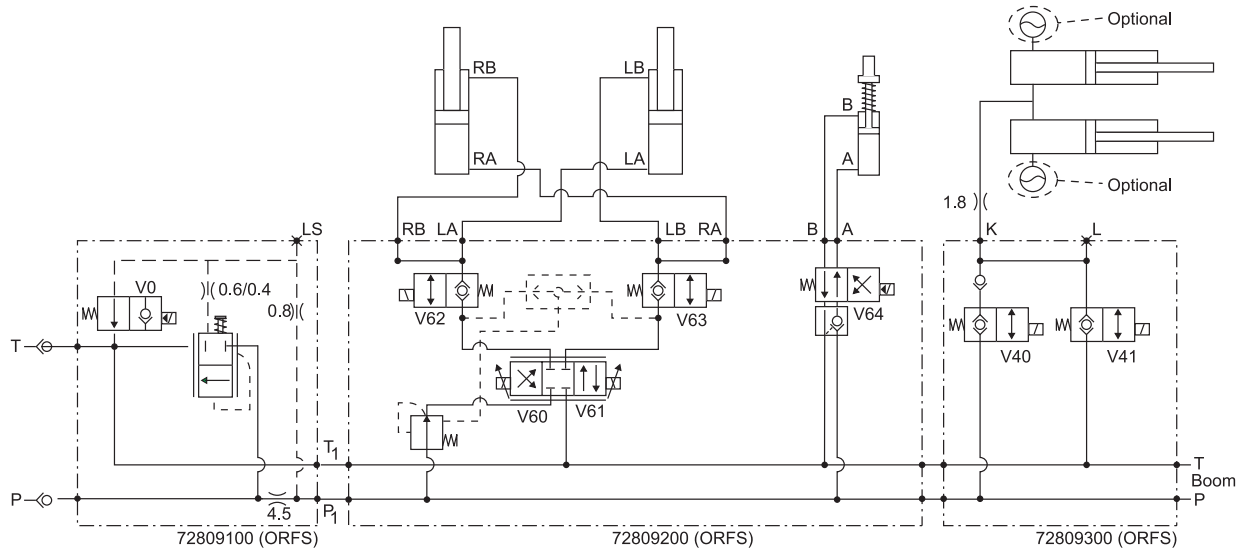

Warranty policy and conditions

HARDI® NORTH AMERICA INC. , 1500 West 76th Street, Davenport, Iowa, USA hereinafter called "HARDI®", offers the following limited warranty in accordance with the provisions below to each original retail purchaser of its own manufacturer, from an authorized HARDI® dealer that such equipment is at the time of delivery to such purchaser, free from defects in material and workmanship and that such equipment will be warranted for a period of one year from the time of delivery to the end user, providing the machine is used and serviced in accordance with the recommendations in the Operator's Manual and is operated under normal farm conditions.

1. This limited warranty is subject to the following exceptions:
 - a)Parts of the machine not manufactured by HARDI®, (i.e. engines, tires, tubes, electronic controls and other components or trade accessories, etc.) are not covered by this warranty but are subject to the warranty of the original manufacturer. Any claim falling into this category will be taken up with the manufacturer concerned.
 - b)This warranty will be withdrawn if any equipment has been used for purposes other than for which it was intended or if it has been misused, neglected, or damaged by accident, let out on hire or furnished by a rental agency. Nor can claims be accepted if parts other than those manufactured by HARDI® have been incorporated in any of our equipment. Further, HARDI® shall not be responsible for damage in transit or handling by any common carrier and under no circumstances within or without the warranty period will HARDI® be liable for damages of loss of use, or damages resulting from delay or any consequential damage.
2. We cannot be held responsible for loss of livestock, loss of crops, loss because of delays in harvesting or any other expense or loss incurred for labor, supplies, substitute machinery, rental for any other reason, or for injuries either to the owner or to a third party, nor can we be called upon to be responsible for labor charges, other than originally agreed, incurred in the removal or replacement of components.
3. The customer will be responsible for and bear the costs of:
 - a)Normal maintenance such as greasing, maintenance of oil levels, minor adjustments including the boom.
 - b)Transportation of any HARDI® product to and from where the warranty work is to be performed.
 - c)Dealer travel time to and from the machine or to deliver and return the machine from the service workshop for repair unless otherwise dictated by state law.
 - d)Dealer traveling costs.
4. Parts defined as normal wearing items, (i.e. Pump Diaphragms, Valves, O-rings, Tires and V-belts) are not in any way covered under this warranty.
5. This warranty will not apply to any product which is altered or modified without the express written permission of the HARDI® Service and Engineering Departments and/or repaired by anyone other than an Authorized HARDI® Dealer.
6. Warranty is dependent upon the strict observance by the purchaser of the following provisions:
 - a)That this warranty may not be assigned or transferred to anyone.
 - b)That the Warranty Registration Certificate has been correctly completed by dealer and purchaser with their names and addresses, dated, signed and returned to the appropriate address as given on the Warranty Registration Certificate within 30 days of delivery to the purchaser.
 - c)That all safety instructions in the operator's manual shall be followed and all safety guards regularly inspected and replaced where necessary.
7. No warranty is given on second-hand products and none is implied.
8. Subject to the following terms, conditions and contributions, HARDI® extends the warranty on polyethylene tanks (excluding fittings, lids and gaskets) to FIVE YEARS on field sprayers. To qualify for this extended warranty, the tank must be drained and flushed with fresh water after each day's use. HARDI®'s liability is limited to replacement of defective parts FOB our plant in Davenport, IA at no cost to the purchaser for the first twelve months after date of purchase; at 20% of the then current retail price during the second year; at 40% during the third year; at 60% during the fourth year; and at 80% during the fifth year. This extended warranty is subject, in each instance, to the tank being inspected and approved for replacement or repair by HARDI® personnel before HARDI® will accept any liability hereunder.
9. Subject to the following terms, conditions and contributions, HARDI® extends the warranty on HARDI® diaphragm pumps (excluding wearing parts such as diaphragms, valves and o-rings) to FIVE YEARS. To qualify for this extended

9 - Warranty

warranty, the pump must be drained and flushed with fresh water after each day's use. HARDI®'s liability is limited to replacement of defective parts, FOB our plant in Davenport, IA at no cost to the purchaser during the first twelve months after date of purchase; at 20% of the then current retail price during the second year; at 40% during the third year; at 60% during the fourth year; and at 80% during the fifth year. This five year extended warranty is subject, in each instance, to the pump being inspected and approved for replacement or repair by HARDI® personnel before HARDI® will accept any liability hereunder.

10. HARDI® reserves the right to incorporate any change in design in its products without obligation to make such changes on units previously manufactured.
11. The judgement of the HARDI® Service Department in all cases of claims under this warranty shall be final and conclusive and the purchaser agrees to accept its decisions on all questions as to defect and the repair or exchange of any part or parts.
12. No employee or representative is authorized to change this warranty in any way or grant any other warranty unless such change is made in writing and signed by the CEO in the Davenport office. Approval of warranty is the responsibility of the HARDI® Service Department.
13. Any warranty work performed which will exceed \$1000.00 MUST be approved IN ADVANCE by the Service Department. Warranty claims filed without prior approval will be returned.
14. ANY pump replacement MUST be approved by the HARDI® Service Department.
15. Claims under this policy MUST be filed with the HARDI® Service Department within thirty (30) days of when the work is performed or warranty shall be void unless prior arrangements are made.
16. Parts which are requested for return by the HARDI® Service Department must be returned prepaid within thirty (30) days for warranty settlement.
17. Warranty claims must be COMPLETELY filled out including part numbers and quantities or claims will be returned to the submitting dealer.

DISCLAIMER OF FURTHER WARRANTY

THERE ARE NO WARRANTIES, EXPRESSED OR IMPLIED, EXCEPT AS SET FORTH ABOVE. THERE ARE NO WARRANTIES WHICH EXTEND BEYOND THE DESCRIPTION OF THE PRODUCT CONTAINED HEREIN. IN NO EVENT SHALL THE COMPANY BE LIABLE FOR INDIRECT, SPECIAL OR CONSEQUENTIAL DAMAGES (SUCH AS LOSS OF ANTICIPATED PROFITS) IN CONNECTION WITH THE RETAIL PURCHASER'S USE OF THE PRODUCT.

Index**A**

Agitation before resuming a spray job, 55
AutoTerrain, 24

C

Chemical Container Rinsing lever, 21
ChemLocker, 31
Clean water tank, 19
CycloneFilter, 20, 41

D

Drain valve, 62
Drawbars
 Rigid drawbar, 28
 Suspended drawbar, 28
Dual tire setup, 43, 44
DynamicFluid4, 17

E

EasyClean filter, 19
Emergency operation, 80
 EasyClean filter, 80
 Liquid system, 80
External Cleaning Device, 30

F

Fault codes - HC 6500, 80
Filling chemicals through tank lid, 50
Filling liquid chemicals by HARDI TurboFiller, 51
Filling of clean water tank, 49
Filling of rinsing tank, 49
Filling of water, 48
Filling powder chemicals by HARDI TurboFiller, 52
Filling through tank lid, 48
Filters, 19
Frame, 15

H

Hydraulic blocks
 AutoHeight UC5, 26
 Boom, 25
 Open center hydraulics, 26
 ParaLift, 25
 SafeTrack, 26
Hydraulic support leg, 29, 34
Hydraulic systems, 37

I

Identification plates, 14

L

Label explanation, 10
Liquid system, 48
Lubrication
 Drawbar, 63
 Trailer/ParaLift, 64

N

Nozzle pressure gauge, 30

O

Open center hydraulics, 38

P

P.T.O. installation, 35
Platform, 28
Plumbing Diagram
 Basic liquid system, 22
 Liquid system with optional extras, 23
Poison information center, 12
Power supply, 40
Pump, 16

Q

Quick Fill, 49
Quick reference - Cleaning, 57
Quick reference - Operation, 55

R

R.P.M. Transducer for pump, 44
Recommended lubricants, 63
Rinsing tank, 19
Roadworthiness, 14

S

SafeTrack, 27
 Driving technique, 27
SafeTrack potentiometer connection, 36
Safety precautions, 50
SafetyLocker, 31
Speed transducer, 40
Sprayer use, 15
Symbols, 9

T

Tank level indicator, 30
Tanks, 15
Technical residue, 61
Track width adjustment, 42
Transmission shaft, 35
TurboDeflector valve, 21
TurboFiller, 21
TurboFiller rinsing, 53
TurboFiller suction valve, 21

U

Unloading the sprayer, 33

V

Valves and symbols, 16



HARDI® North America Inc.

1500 West 76th St - Davenport, IA 52806

Ph: (563) 386-1730

Customer Service Email: custserv@hardi-us.com

Email: info@hardi-us.com

Website: www.hardi-us.com