



ESTATE SPRAYERS

BNL

Operator's Manual

67301203 (6/01)

HARDI® reserves the right to make changes in design, material, or specification without notice thereof. HARDI® and other product names are registered trademarks of HARDI® Inc. in the U.S. and in other countries.



TABLE OF CONTENTS

1.0 INTRODUCTION	4
2.0 SAFETY INFORMATION	5
2.1 Follow Safety Instructions	6
2.2 Operating The Sprayer Safely	7
2.3 Handling Chemical Products Safely	8
2.4 Local Poison Information Center	9
3.0 HOOKING UP THE SPRAYER	10
3.1 P.T.O. Shaft Operator Safety	11
3.2 Installation of P.T.O. Shaft	11
4.0 OPERATING THE SPRAYER	13
4.1 M70 Manual Control Operation	14
5.0 NOZZLE SELECTION	16
5.1 Handgun Nozzle Selection	16
5.2 Boom Nozzle Selection	16
6.0 CALIBRATION	18
6.1 Calibration (Ounce Method)	19
6.2 Calibration (Nozzle Catch Test)	19
7.0 MAINTENANCE	20
7.1 Cleaning The Sprayer	20
7.2 Lubrication	22
7.3 Nozzle Filters	23
7.4 Nozzle Tubes and Fittings	23
7.5 Pump Maintenance	24
8.0 STORAGE	25
8.1 Preparation After Storage	25
9.0 TROUBLESHOOTING	26
10.0 TECHNICAL SPECIFICATIONS	28
10.1 HARDI® Diaphragm Pump Specifications	28
10.2 Sprayer Specifications	28
10.3 Safety Decals	28
11.0 PARTS DRAWINGS	29
12.0 WARRANTY POLICY AND CONDITIONS	39



Dear Owner,

Thank you for purchasing a HARDI® product and welcome to the ever-increasing family of HARDI® equipment owners.

Our sprayers and accessories are rapidly becoming a familiar sight on North American farms and estates. We believe that this results from growers becoming increasingly conscious of crop protection input costs and the vital need for cost effective application equipment.

Please take the time to thoroughly read the Operator's Manual before using your equipment. You will find many helpful hints as well as important safety and operation information.

Some of the features on your HARDI® Estate Sprayer were suggested by growers. There is no substitute for "on farm" experience and we invite your comments and suggestions.

Please address your correspondence to the Service Manager at one of these branches:

HARDI® MIDWEST
1500 West 76th St.
Davenport, Iowa 52806
Phone: (563) 386-1730
Fax: (563) 386-1710

HARDI® GREAT LAKES
290 Sovereign Rd.
London, Ontario N6M 1B3
Phone: (519) 659-2771
Fax: (519) 659-2821

HARDI® WEST COAST
5646 W. Barstow, Suite 101
Fresno, California 93722
Phone: (559) 271-3106
Fax: (559) 271-3107

Sincerely,

Tom L. Kinzenbaw
President



1.0 INTRODUCTION

We congratulate you for choosing a HARDI® plant protection product. The reliability and efficiency of this product depends on your care. The first step is to carefully **read and pay attention** to this operator's manual. It contains essential information for the efficient use and long life of this quality product.

This manual covers the HARDI® BNL 50 Estate Sprayer equipped with HARDI® 500 diaphragm pump (540 RPM PTO drive), M70 control, optional 14' HD horizontal fold boom and model 60L spray gun with 25' hose and hose wrap.

The heart of your sprayer is the diaphragm pump. The design is simple, resulting in low maintenance requirements and guaranteed pump life. The bearings and crankshaft are grease lubricated and are therefore protected from spray solution if any diaphragm fails in service. A drain hole is located in the base of the crank case to facilitate the draining of any foreign matter. The pump is self-priming and can be run dry without damage.

The M70 control features: on/off control for boom and handgun, pressure adjustment, safety relief mechanism, pump bypass agitation and a 2-1/2" pressure gauge.

The tank, made of impact proof and chemical resistant polyethylene, has a purposeful design with rounded contours which allows for efficient cleaning and draining. It is designed with a large deep sump so that it can be completely emptied even when the sprayer is used on slopes. A drain plug is provided in the sump to assist in cleaning of the tank.

Also covered in this manual is the 14' HD boom which features fore and aft breakaway and ISO flat fan nozzles with 20" spacing. The 14' HD boom folds horizontally forward.

The frame and boom of your estate sprayer are finished with a powder coat paint which provides maximum protection from chemicals and rust.

The model 60L spraygun features an adjustable spray nozzle for varying the spray width. The standard spraygun features 25' of 1/2" hose on the hose wrap. An optional 40' hose is available.



BNL 50 Estate Sprayer with 14' HD Boom

2.0 SAFETY INFORMATION

WARNING!



**ALWAYS READ THE OPERATOR'S MANUAL BEFORE
USING THIS EQUIPMENT**

**DO NOT REMOVE ANY SAFETY DEVICES OR
SHIELDS. NEVER SERVICE, CLEAN OR REPAIR A
MACHINE WHILE IT IS OPERATING**





2.0 SAFETY INFORMATION (cont.)

WARNING!



**ALWAYS WATCH FOR THIS SYMBOL TO POINT OUT
IMPORTANT SAFETY PRECAUTIONS**

**IT MEANS ATTENTION! BECOME ALERT!
YOUR SAFETY IS INVOLVED!**

RECOGNIZE SAFETY INFORMATION



This is the Safety-alert symbol. When you see this symbol on your machine or in this manual, be alert to the potential for personal injury.

Follow recommended precautions and safe operating practices.

2.1 Follow Safety Instructions

1. Carefully read all the safety messages in this manual and the safety labels fitted to the machine. Keep safety labels in good condition. Replace missing or damaged safety labels. Make sure that new equipment components include any current safety labels. Replacement safety labels are available from your authorized HARDI® dealer.
2. Learn how to operate the sprayer and how to use the controls properly. Do not let anyone operate the sprayer without proper instructions.
3. Keep your sprayer in proper working condition. Unauthorized modifications or use may impair the function and/or safety and affect the machine's life.
4. If you do not understand any part of this manual and need assistance, please contact your authorized HARDI® dealer.

2.2 Operating The Sprayer Safely



1. Read the complete manual carefully and become familiar with the operation of the equipment before initial operation in each spraying season. Failure to do so may result in possible over or under application of spray solution and may lead to personal injury.
2. Always keep children away from your estate sprayer.
3. Before starting the engine on the tractor unit, be sure all operating controls are in the off or neutral position, including but not limited to the P.T.O. shaft and/or spray controls. Be sure the tractor power train is disengaged.
4. Operate spray and boom functions only when seated in the operator's seat. Only one person should be working the machine when in operation.
5. Before leaving the tractor seat, stop the engine, put all controls in neutral, and put the transmission control lever in the park position or neutral with the brakes locked. Read the tractor operation manual for added safety precautions.
6. P.T.O. driven equipment can cause serious injury. Before working on or near the P.T.O. shaft, servicing or cleaning the equipment, put P.T.O. lever in the DISENGAGE position and stop the engine.
7. Keep hands, feet & clothing away from moving parts.
8. Wear relatively tight and belted clothing to prevent from being caught on some part of the machine.
9. Slow down when turning especially with boom unfolded.
10. Before transporting the sprayer ensure that the boom is fully folded and fully locked into transport position.
11. Slow moving tractors and spray equipment can create a hazard when on public roads. Avoid personal injury or death resulting from any accidents by using flashing lights. Local regulations may require installation of flashing warning lights.
12. Understand service procedures before undertaking any maintenance. Never lubricate, service, or adjust the machine while it's moving. Securely support any components before working on them.
13. Keep all parts in good condition and properly installed. Repair damaged parts immediately. Replace worn or broken parts.



2.3 Handling Chemical Products Safely

1. Direct exposure to hazardous chemicals can cause serious injury. These chemicals can include lubricants, coolants, paints, adhesives and agricultural chemicals. Material Safety Data Sheets (M.S.D.S.) are available for all hazardous chemicals which inform the user of specific details including, physical and health hazards, safety procedures, and emergency response techniques.
2. Protective clothing such as rubber gloves, goggles, coveralls and respirator must be worn while handling chemicals. All protective clothing should be kept in excellent condition and cleaned regularly or discarded.
3. If chemicals come in contact with any exposed skin areas, wash immediately with clean water and detergent. Never place nozzle tips or any other components that have been exposed to chemicals to lips to blow out obstructions. Use a soft brush to clean spray nozzles.
4. Dedicate an area to fill, flush, calibrate and decontaminate sprayer where chemicals will not drift or run off to contaminate people, animals, vegetation, water supply, etc. Locate this area where there is no chance of children coming in contact with this residue.
5. Decontaminate equipment used in mixing, transferring and applying chemicals after use. Follow the instructions on the chemical label for the correct procedure required. Wash spray residue from outside of the sprayer to prevent corrosion.
6. Extreme care should be taken in measuring spray products. Powders should be used in suitable sized packages or weighed accurately. Liquids should be poured into a suitable graduated container. Keep chemical containers low when pouring. Wear a filtered respirator and let the wind blow away from you to avoid dust and/or splashes contacting the skin or hair.
7. Store chemicals in a separate, plainly marked locked building. Keep the chemical in its original container with the label intact.
8. Dispose all empty containers after rinsing in accordance with local regulations & by-laws. Dispose of all unused chemicals and left over fertilizer in an approved manner
9. Keep a first aid kit and fire extinguisher available at all times when handling chemicals.

2.4 Local Poison Information Center

PHONE NO. _____ - _____ - _____



Find the phone number for the poison control center in your phone book and write it in the space above.

Keep a list, in the space provided below, of all the chemicals that you have in use.

1. _____
2. _____
3. _____
4. _____
5. _____
6. _____
7. _____
8. _____
9. _____
10. _____

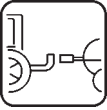

3.0 HOOKING UP THE SPRAYER

WARNING: *MAKE SURE THAT YOUR LAWN & GARDEN OR COMPACT TRACTOR HAS SUFFICIENT HORSEPOWER, BRAKING ABILITY AND CARRYING CAPACITY TO SAFELY CONTROL THE TRACTOR WITH THE SPRAYER MOUNTED.*

Sprayer	Total Loaded Weight (lbs.)	Empty Weight (lbs.)
BNL 50	640	225

1. Attach lower lift arms.
2. Attach PTO shaft (See sections 3.1 and 3.2).
3. Attach top link.



IMPORTANT: *Make absolutely sure that the correct 3 point hitch pins are used and that they are securely installed.*

4. Raise sprayer from ground and adjust 3 point linkage so that tank is level in the raised position (ensure that the sprayer tank is level from side to side as well as front to back).
5. Also follow these general recommendations:
 - Increase tire pressure if necessary (refer to tractor operator's manual) to compensate for the added weight.
 - Make sure that no parts of the sprayer come into contact with the tractor.
 - Be careful when filling the sprayer for the first time.
 - Travel at slower speeds when driving with a full tank.

3.1 P.T.O. Shaft Operator Safety

WARNING: ALWAYS STOP ENGINE BEFORE ATTACHING THE TRANSMISSION SHAFT TO TRACTOR P.T.O. MOST TRACTOR P.T.O. SHAFTS CAN BE ROTATED BY HAND TO FACILITATE SPLINE ALIGNMENT, WHEN ENGINE IS STOPPED.

When attaching the shaft, make sure that the snap lock is FULLY ENGAGED - push and pull shaft until it locks.

WARNING: ROTATING TRANSMISSION SHAFTS WITHOUT PROTECTION GUARDS ARE FATAL.

Always keep protection guards and chains intact and make sure that the guards cover all rotating parts, including CV-joints at each end of the shaft. Do not use without protection guard.

Do not touch or stand on the transmission shaft when it is rotating - safety distance: min 5' (1.5 meters).

Prevent protection guards from rotating by attaching the chains allowing sufficient slack for turns.

Make sure that protection guards around the tractor P.T.O. and implement shaft is intact. Always STOP ENGINE and remove the ignition key before carrying out maintenance or repairs to the transmission shaft or implement.

3.2 Installation Of P.T.O. Shaft

WARNING: THE P.T.O. SHAFT ANGLE WILL CHANGE WHEN RAISING AND LOWERING THE 3 POINT LINKAGE. TO PREVENT EXCESSIVE LOADING AND BINDING ON THE P.T.O. SHAFT, IT MAY BE ADVISABLE TO LEAVE THE P.T.O. SHAFT DISCONNECTED UNTIL THE LINKAGE ADJUSTMENT IS COMPLETED. THEN THE P.T.O. SHAFT ADJUSTMENTS CAN BE MADE.

Initial installation of the shaft is done as follows:

1. Attach sprayer to tractor and set sprayer in the position with **shortest** distance between the tractor and sprayer pump P.T.O. shafts.
2. Stop engine and remove ignition key.

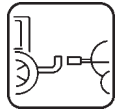

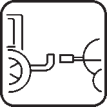

3.2 Installation Of P.T.O. Shaft (cont.)

3. If P.T.O. shaft must be shortened, the shaft is pulled apart. Fit the two shaft parts at tractor and sprayer pump and measure how much it is necessary to shorten the shaft. Mark the protection guards.

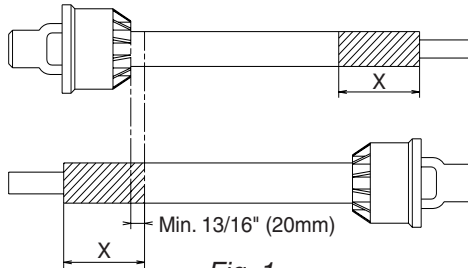

Fig. 1

- Note:** The shaft must always have a minimum overlap of 6" (150 mm) (Fig. 2).

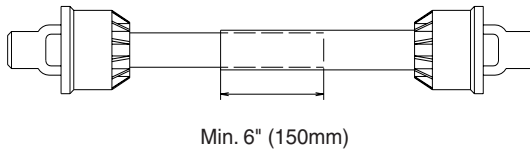

Fig. 2

4. The two parts are shortened equally. Use a saw, and file the profiles afterwards to remove burrs (Fig. 3).
5. Grease the profiles, and assemble male and female parts again.

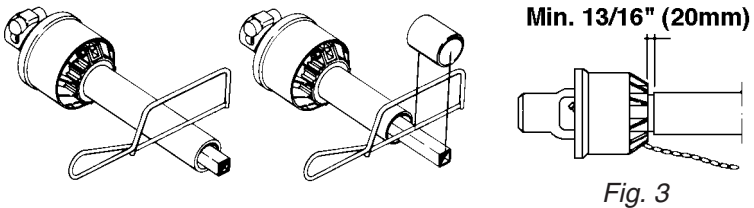
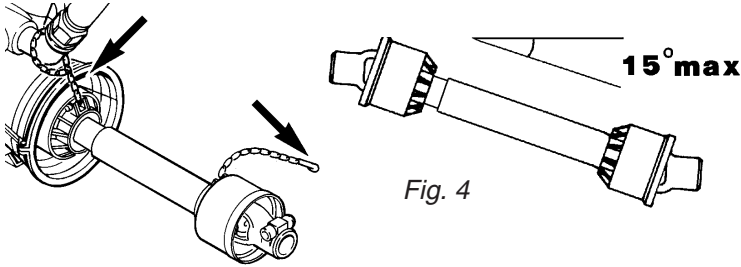

Fig. 3

6. Fit the shaft to tractor and sprayer pump.

Note: Female part towards tractor. Fit the chains to prevent the protection guards to rotate with the shaft.

7. To ensure long life of the P.T.O. shaft, try to avoid working angles greater than 15° (Fig. 4).



4.0 OPERATING THE SPRAYER

WARNING: ALWAYS FILL YOUR ESTATE SPRAYER WITH CLEAN WATER ONLY. ALWAYS FILL WATER THROUGH THE STRAINER BASKET TO PREVENT FOREIGN PARTICLES FROM ENTERING THE TANK. NEVER LET THE FILLING HOSE ENTER THE TANK. CHEMICALS MAY CONTAMINATE THE WATER SUPPLY LINES, PLANT AND/OR WELL.

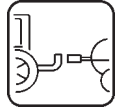
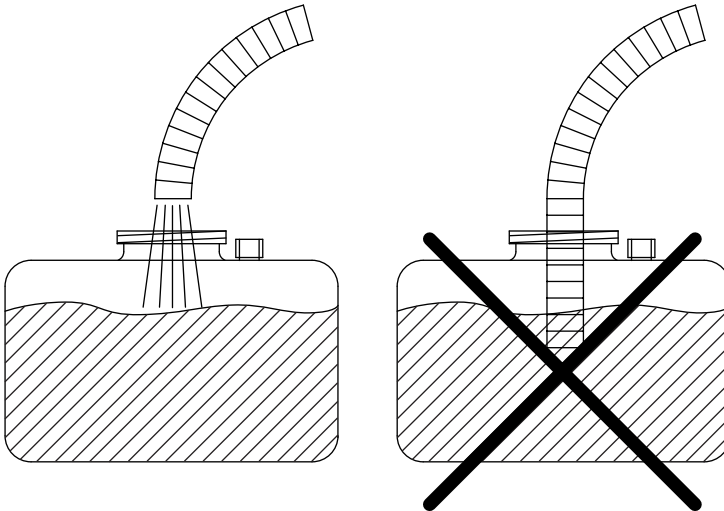



4.1 M70 MANUAL CONTROL OPERATION

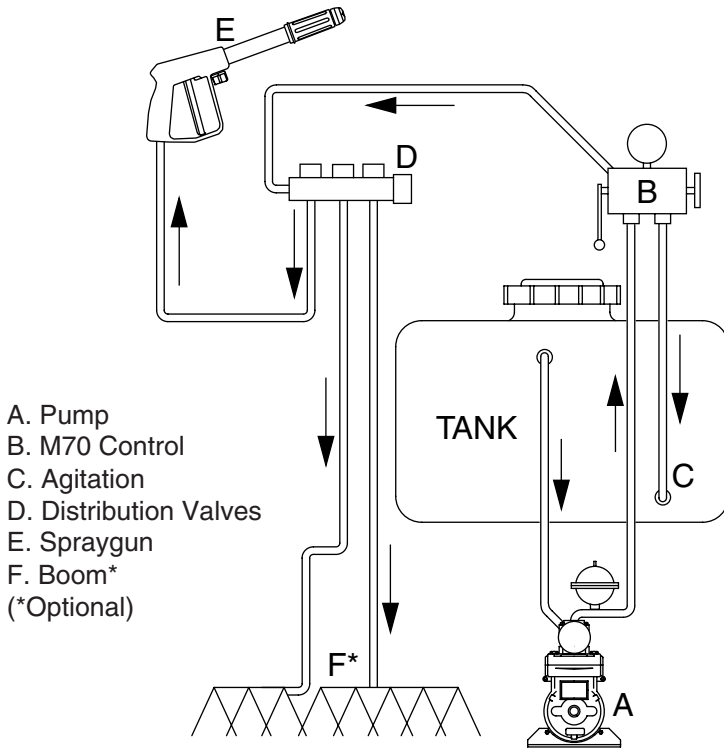

Fig. 5

Fluid System Overview

When the pump **A** (Fig. 5) is running, pressurized fluid flows from the pump to the M70 control **B** (Fig. 5). Fluid that is not required for use by the boom or spraygun is returned to the tank through the bypass line and agitation nozzle **C** (Fig. 5). If the sprayer is equipped with a boom, the distribution valves **D** (Fig. 5) control the flow to the boom lines as well as the spraygun. When the boom valves are open, fluid flows to the boom **F** (Fig. 5). When the spraygun valve is open and the red handle **5** (Fig. 6) on the spraygun is depressed, fluid flows to the spraygun **E** (Fig. 5).

Spraygun/(Optional Boom) Operation

1. Locate your sprayer in a suitable location to spray water from the spraygun (and/or optional boom).
2. Fill the tank with clean water.

- Open boom to working position and turn knob **A** (Fig. 6) counter-clockwise all the way out.
- Make sure the air pressure in the pump pulsation damper is as noted below:

OPERATING SPRAYER PRESSURE (PSI)	REQUIRED PULSATION DAMPER PRESSURE (PSI)
20-40	0-14
40-210	14-42

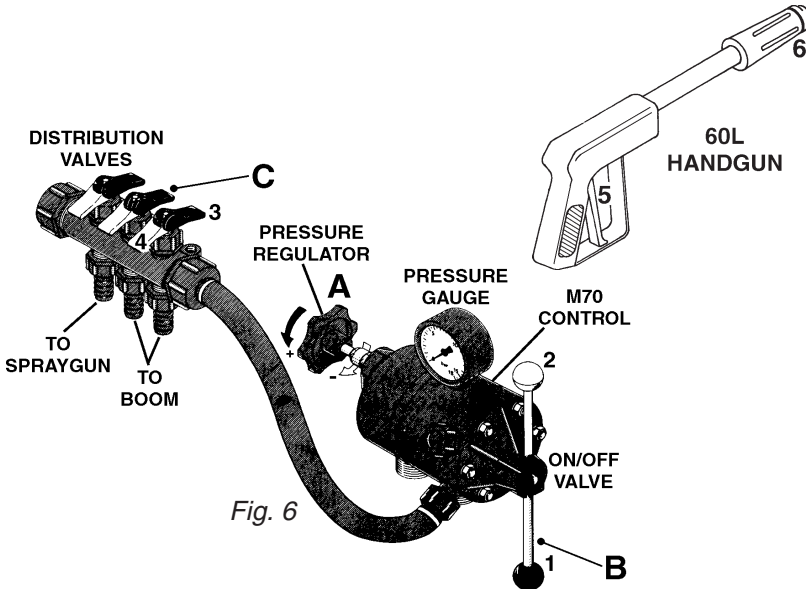
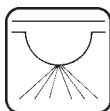

Fig. 6

- Place handle **B** (Fig. 6) in position **2** (OFF).
- Start tractor and run engine to produce maximum 540 PTO RPM.
- Place handle **B** (Fig. 6) in position **1** (ON). If optional boom is installed, set levers **C** (Fig. 6) in position **3** (ON).
- Adjust spraying pressure to desired level by turning knob **A** (Fig. 6) clockwise. Look in tank and check for adequate agitation.
- To operate the spraygun, depress the red handle **5** (Fig. 6) to spray water from the spraygun. Follow step **8** to adjust pressure. To adjust the spray pattern, turn the black handle **6** (Fig. 6) **OUT** for a narrow spray pattern for long distances and **IN** for a wide pattern for more coverage at close distances.
- To stop liquid flow to the spraygun (and optional boom), place handle **B** (Fig. 6) in position **2** (OFF).



5.0 NOZZLE SELECTION

As standard equipment with your estate sprayer, nozzles have been provided for both the handgun and boom.

5.1 Handgun Nozzle Selection

The 1099-20 nozzle (HARDI® ref. no. 371314) is the standard nozzle for the handgun. This nozzle supplies the following rates in U.S. gallons per minute at the given pressures:

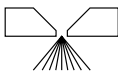
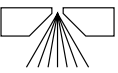
NOZZLE	PSI	GPM	
			
1099-20	20	0.678	0.538
	30	0.829	0.661
	40	0.956	0.766
	50	1.068	0.857
	60	1.169	0.940
	70	1.261	1.018
	100	1.504	1.222
	150	1.840	1.500
200	2.123	1.736	

Other size 1099 nozzles are available from you HARDI® Dealer.

5.2 Boom Nozzle Selection

ISO F-03-110 BLUE nozzles (HARDI® ref. no. 371767) are standard on the 14' HD boom. If you find by using the following directions and nozzle chart, that these nozzles are not the correct size for your spraying needs, other nozzles are available from your HARDI® Dealer.



NOTE: A Calibration & Nozzles Manual (HARDI® ref. no. 67000103) is available from your HARDI® dealer which contains more detailed information for calibration and nozzle selection.

TO USE THE FOLLOWING CHART:

1. You must know your desired forward speed (example 3 MPH).
2. You must know the pressure (PSI) you want to spray at (example 30 PSI).
3. You must know your desired application rate (example 16 gallons per acre).

KNOWING THESE THREE FACTS, PROCEED AS FOLLOWS:

1. Locate the correct speed column on the chart below (example 3 M.P.H.).
2. Find the number in that column which is closest to your desired application rate and is also opposite the desired pressure (example 16.8 GPA is closest to 16 GPA and opposite 30 PSI).
3. For this example, you would select the F-02-110 YELLOW nozzle.

NOTE: Using this chart will bring you very close to your desired application rate. However, for final pressure setting, you must calibrate your sprayer (Section 6.0).

HARDI® ISO F-110 SPRAY SYNTAL NOZZLES

NOZZLE	PSI	GPM	GPA at MPH					
			2 MPH	3 MPH	4 MPH	5 MPH	6 MPH	
ISO F-01-110 ORANGE (371764)	20	0.071	10.5	7.0	5.3	4.2	3.5	
	30	0.087	12.9	8.6	6.5	5.2	4.3	
	40	0.100	14.8	9.9	7.4	5.9	5.0	
	50	0.113	16.8	11.2	8.4	6.7	5.6	
	60	0.122	18.1	12.1	9.1	7.2	6.0	
ISO F-015-110 GREEN (371765)	20	0.11	16.3	10.9	8.2	6.5	5.4	
	30	0.13	19.3	12.9	9.7	7.7	6.4	
	40	0.15	22.2	14.8	11.1	8.9	7.4	
	50	0.17	25.2	16.8	12.6	10.1	8.4	
	60	0.18	26.7	17.8	13.3	10.7	8.9	
ISO F-02-110 YELLOW (371766)	20	0.14	20.8	13.9	10.4	8.3	6.9	
	30	0.17	25.2	16.8	12.6	10.1	8.4	
	40	0.20	29.7	19.8	14.8	11.9	9.9	
	50	0.23	34.1	22.8	17.1	13.7	11.4	
	60	0.24	35.6	23.8	17.8	14.3	11.9	
ISO F-025-110 LILAC (371950)	20	0.18	26.7	17.8	13.4	10.7	8.9	
	30	0.22	32.7	21.8	16.3	13.1	10.9	
	40	0.25	37.1	24.8	18.8	15.0	12.5	
	50	0.28	41.6	27.7	20.8	16.6	13.9	
	60	0.31	46.0	30.7	23.0	18.4	15.4	
ISO F-03-110 BLUE (371767)	20	0.21	31.1	20.8	15.6	12.5	10.4	
	30	0.26	38.6	25.7	19.3	15.4	12.9	
	40	0.30	44.6	29.7	22.3	17.8	14.8	
	50	0.34	50.5	33.7	25.2	20.2	16.8	
	60	0.37	54.9	36.6	27.5	22.0	18.3	
ISO F-04-110 RED (371768)	20	0.28	41.6	27.7	20.8	16.6	13.9	
	30	0.35	52.0	34.7	26.0	20.8	17.3	
	40	0.40	59.4	39.6	29.7	23.8	19.8	
	50	0.45	66.8	44.6	33.4	26.7	22.3	
	60	0.49	72.8	48.5	36.4	29.1	24.3	

NOTE: Never operate the sprayer with nozzle pressure under 20 PSI to maintain the proper spray pattern.

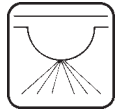



6.0 CALIBRATION

WARNING: ALWAYS CALIBRATE YOUR SPRAYER WITH CLEAN WATER ONLY! WEAR PROTECTIVE CLOTHING SUCH AS RUBBER GLOVES, GOGGLES AND COVERALLS.



Why must you calibrate a sprayer?

A nozzle selection chart will tell you what application rate you should expect. Variations due to nozzle wear, errors in pressure adjustment, and tractor speedometer can result in a large error in application rate.

How do you calibrate a sprayer?

Calibration kits are available from HARDI®, #818493 for U.S. Gallons and #818492 for metric calibration. For accurate calibration, the sprayer is driven a specific distance at spraying speed and the length of time is recorded. The operator then measures the amount of water sprayed from one nozzle at spraying pressure for the same length of time noted. The amount of water sprayed provides a direct reading of application rate. Slight adjustments are then made by varying the pressure.

Here are some tips to remember when using the calibration kit method:

1. Calibrate with clean water only.
2. Follow the instructions in the calibration kit carefully.
3. Before calibration, check the flow of each nozzle (Section 6.2). If it puts out more than 10% of its original volume, replace it.
4. When determining the length of time required to drive a recommended distance, drive in actual field or lawn conditions with a half full sprayer. Repeat the test several times, then take the average of the times recorded.
5. Calibration of the sprayer should be completed at the beginning of the season and repeated every 2 to 3 full days of spraying, and every time you change volume rate or use different nozzles.



NOTE: A Calibration & Nozzles Manual (HARDI® ref. no. 67000103) is available from your HARDI® dealer which contains more detailed information for calibration and nozzle selection.

6.1 Calibration (Ounce Method)

If you do not wish to use the calibration kit method, the following method may be used. All you need is a tape measure, stop watch and a container that accurately measures U.S. fluid ounces.



1. Fill the sprayer tank approximately half full with clean water.
2. Set up two stakes, 204 ft. apart in actual spraying conditions.
3. While driving at spraying speed, note the length of time required to drive 204 ft. Repeat several times and take the average of the times recorded.
4. With the sprayer operating at intended spraying pressure, collect the output from one nozzle for the length of time determined in step 3. The number of U.S. fluid ounces will exactly measure the application rate.

e.g. 15 U.S. fluid ounces = 15 U.S. gallons per acre

NOTE: This method only works if the nozzle spacing is 20”.

For conversion to Imperial gallons per acre, multiply U.S. GPA x .833

For conversion to liters per hectare, multiply U.S. GPA x 9.34

For conversion to liters per acre, multiply U.S. GPA x 3.78



6.2 Calibration (Nozzle Catch Test)

The following steps may be used to check the actual flow through the nozzles to check for wear.

1. Fill the sprayer with clean water.
2. Operate the boom and set to desired pressure.
3. Shut the boom off and place 2 or 3 empty containers under 2 or 3 nozzles.
4. Turn boom back on and run for 1 minute.
5. Measure the amount caught in the containers and compare to the GPM figure on the nozzle chart for the nozzle being used (See section 5.0 or refer to the HARDI® Calibration & Nozzles Manual ref. no. 67000103).



7.0 MAINTENANCE

WARNING: *UNCLEAN SPRAYERS CAN BE HAZARDOUS TO PEOPLE AND ANIMALS. NEVER LEAVE A SPRAYER CONTAINING CHEMICALS WHERE IT COULD BE ACCESSED BY UNAUTHORIZED PEOPLE OR ANIMALS.*



IMPORTANT: *Always clean the boom at the end of your workday or before servicing to avoid unnecessary contact with chemicals.*

In order to derive full benefit from the sprayer for many years, the following few, but important rules should be followed.



7.1 Cleaning The Sprayer

Read the entire label of the chemical used. Take note of any particular instructions regarding recommended protective clothing, deactivating agents, etc. Read the detergent and deactivating agent labels. If cleaning procedures are given, follow them closely.

Be familiar with local legislation regarding disposal of agricultural chemicals, mandatory decontamination methods, etc. Contact the appropriate office, e.g. Department of Agriculture.

Cleaning starts with calibration, as a well calibrated sprayer will ensure the minimal amount of remaining spray liquid. It is a good practice to clean the sprayer immediately after use thereby rendering the sprayer safe and ready for the next application. This also prolongs the life of the components.

It is sometimes necessary to leave the spray liquid in the tank for short periods of time (e.g. overnight), or until the weather becomes suitable for spraying again. Unauthorized persons and animals must not have access to the sprayer under these circumstances.

Cleaning

1. Dilute the remaining spray liquid in the tank with at least 10 parts water and spray the liquid out into the field or lawn you have just sprayed.
2. Select and use the appropriate protective clothing. Select detergent suitable for cleaning and suitable deactivation agents if necessary.
3. Rinse and clean sprayer and tractor externally. Use detergent if necessary.

4. Remove all filters and clean them. Be careful not to damage the mesh. Replace filters when the sprayer is completely clean.
5. With the pump running, rinse the inside of the tank. Remember the tank roof. Rinse and operate all components and any equipment that has been in contact with the chemical.
6. After spraying the liquid out again in the field or lawn, stop the pump and fill at least 1/5 of the tank with clean water. Note that some chemicals require the tank to be completely filled. Add appropriate detergent and/or deactivating agent, e.g. Washing soda or Triple ammonia.

NOTE: If a cleaning procedure is given on the chemical label, follow it closely.

7. Start the pump and operate all controls enabling the liquid to come in contact with all the components. Leave the distribution valves until last. Some detergents and deactivating agents work best if left in the tank for a short period. Check the label.
8. Drain the tank and let the pump run dry. Rinse inside of tank, again letting the pump run dry.
9. Stop the pump. If the chemicals used have a tendency to block nozzles, remove and clean them now.
10. Replace all filters and nozzles and store the sprayer. If, from previous experiences, it is noted that the solvents in the chemicals are particularly aggressive, store the sprayer with the tank lid open.

NOTE: If the sprayer is cleaned with a high pressure cleaner, we recommend lubrication of the entire machine.





7.2 Lubrication

Every 40 hours of operation, new grease should be applied to the pump and boom. Use a high quality multi-purpose lithium based grease. When greasing the pump, use only 2 to 3 pumps from a grease gun. For easier application of grease to the boom, place the wing in the breakaway position. Also oil the M70 control as shown every 40 hours of operation.



WARNING: TO PREVENT SERIOUS INJURY FROM CRUSHING, NEVER PLACE FINGERS IN BREAKAWAY CLUTCH.

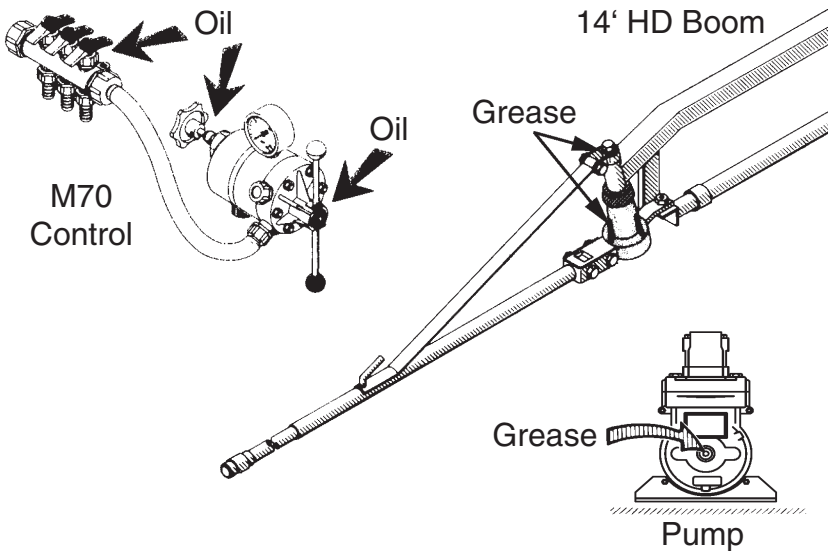

7.3 Nozzle Filters

WARNING: NEVER SERVICE YOUR CONTAMINATED NOZZLES WITHOUT WEARING CHEMICAL RESISTANT GLOVES AND SAFETY GOGGLES.

Each nozzle assembly is equipped with a 50 mesh filter screen as standard. A properly maintained suction filter will eliminate plugging of the screens and nozzles.

7.4 Nozzle Tubes and Fittings

Poor seals are usually caused by:

- Missing O-rings or gaskets
- Damaged or incorrectly seated O-rings
- Dry or deformed O-rings or gaskets
- Foreign materials

Therefore, in case of leaks; **DO NOT** overtighten any fittings (Fig 7). Disassemble, check the condition and position of the O-ring or gasket, clean, lubricate with vegetable oil and then reassemble. For radial seals (O-ring) (Fig 7), only hand tighten the fittings. Do not use pliers or wrenches.

The O-rings need to be lubricated ALL THE WAY AROUND before fitting on to the nozzle.

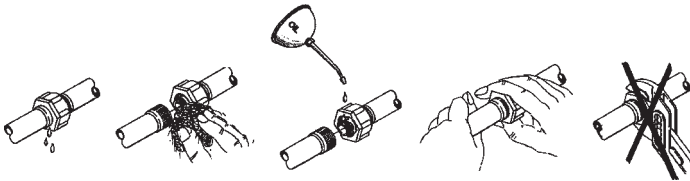

Fig. 7

HARDI® recommends using a vegetable based oil to prolong the life of the O-ring.





7.5 Pump Maintenance

Changing the valves

Remove valve cover **1** (Fig 8). Before changing the valves **2** (Fig 8), note the orientation of the valves so that they may be replaced correctly. Use new seals **3** (Fig 8) when changing or checking the valves.

Changing the diaphragms

Remove the diaphragm cover **4** (Fig 8) after removing the valve cover. The diaphragm **5** (Fig 8) may then be changed. If fluids have reached the crankcase, re-grease the pump thoroughly. Also make sure the drain hole at the bottom of the pump is not blocked. Use the following torque chart when re-tightening bolts:

Diaphragm Bolt - 18.5 Ft/Lbs

Diaphragm Cover Bolts - 37 Ft/Lbs

Valve Cover Bolts - 22 Ft/Lbs

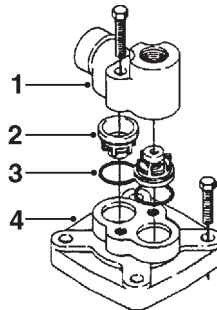
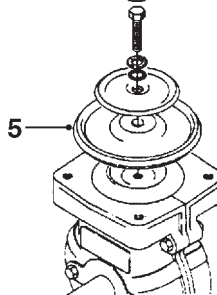

Fig. 8



Model 500

8.0 STORAGE

When the spraying season is over, you should devote some extra time to the sprayer. If chemical residues are left over in the sprayer for long periods, it can reduce the life of the individual components. To preserve the sprayer and protect the components, carry out the following off-season storage program:

1. Clean the sprayer completely - inside and outside - as described in Section 7.1 "Cleaning The Sprayer". Make sure that all valves, hoses and auxiliary equipment have been cleaned with detergent and flushed with clean water afterwards, so no chemical residues are left in the sprayer.
2. Replace any damaged seals and repair any leaks.
3. Empty the sprayer completely and let the pump work for a few minutes. Operate all valves and handles to drain as much water out of the spraying circuit as possible. Let the pump run until air is coming out of all nozzles.
4. Fill the tank with 3 - 5 gallons of an ethylene glycol base anti-freeze mixture at the ratio for the desired temperature protection. Run the pump and circulate the anti-freeze through the distribution valves and boom lines. Spray the handgun into the tank until anti-freeze sprays out to make sure the line is full of anti-freeze.

NOTE: Never use diesel fuel in a sprayer.

5. When the sprayer is dry, remove rust from any scratches in the paint and touch up the paint.
6. Lubricate the boom (Section 7.2).
7. Remove the glycerine-filled pressure gauge and store in a vertical position in a frost-free environment.
8. To protect against dust, the sprayer can be covered by a tarpaulin. Ensure ventilation to prevent condensation.

8.1 Preparation After Storage

After a storage period, the sprayer should be prepared for the next season in the following way:

1. Remove the cover (If fitted).
2. Fit the pressure gauge again. Seal with Teflon tape.
3. Connect the sprayer to the tow vehicle (Section 3.0).
4. Empty the remaining antifreeze into an approved container.
5. Rinse the entire liquid circuit on the sprayer with clean water. Don't forget to flush the boom and handgun lines also.
6. Fill with clean water and check all functions (Section 4.0).





9.0 TROUBLESHOOTING

<i>Problem</i>	<i>Solution</i>
1. Lack of Pressure	<ul style="list-style-type: none">A. Check that suction filter is not clogged.B. Check suction line from tank to pump for leaks.C. Check that pressure regulator seat is not damaged.D. Check pump valves for obstructions and wear. Replace valves if necessary. (Section 7.5)E. Check pressure gauge.
2. Pressure jumping	<ul style="list-style-type: none">A. Check that suction filter is not partially clogged.B. Check that pressure regulator is functioning properly.C. Check that non-drip nozzle diaphragms are functioning correctly (should open at 10 PSI).D. Check pressure gauge.
3. Liquid leaks from bottom of pump	<ul style="list-style-type: none">A. Replace diaphragm(s). (Section 7.5)
4. No spray from spraygun or boom	<ul style="list-style-type: none">A. Check suction tube and fittings.B. Check suction line from tank to pump for leaks.C. Check tightness of pump diaphragm and valve covers. (Section 7.5)

9.0 TROUBLESHOOTING (cont.)



Problem

5. Inadequate weed control

Solution

- A. Re-calibrate sprayer.
- B. Check chemical container instructions.
- C. Did weather conditions affect application?
- D. Take care when driving not to overlap or miss spraying.
- E. Did you stop vehicle in field or lawn and leave sprayer running?

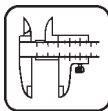

10.0 TECHNICAL SPECIFICATIONS

10.1 HARDI® Diaphragm Pump Specifications

PUMP MODEL	500
Number of Diaphragms	1
Maximum Pressure	220 PSI (15 Bar)
Maximum Flow @540 RPM	4.2 GPM (16 l/min)

10.2 Sprayer Specifications

Sprayer Type	Tank Capacity (Gallons)	Boom Type (Ft.)	Spray Width (Ft.)	Dimensions L x W x H (Inches)	Empty Weight (lbs.)
BNL 50	50	14'	13'4"	53 x 44 x 61	225

10.3 Safety Decals

Red Reflector Decal - 10533803

10532403



10533103

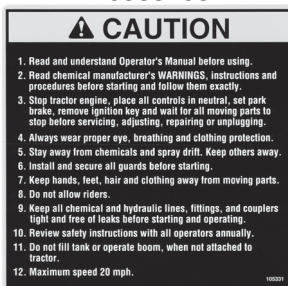

10533203



11.0 PARTS DRAWINGS



BNL 50 FRAME

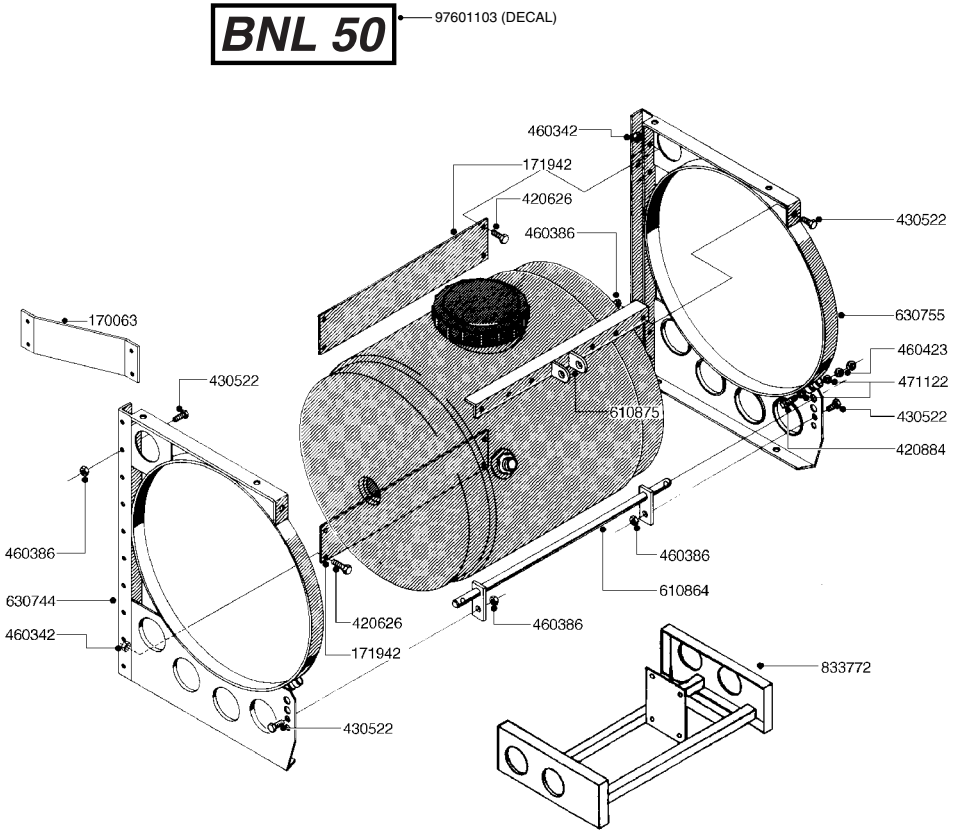



BNL 50 TANK

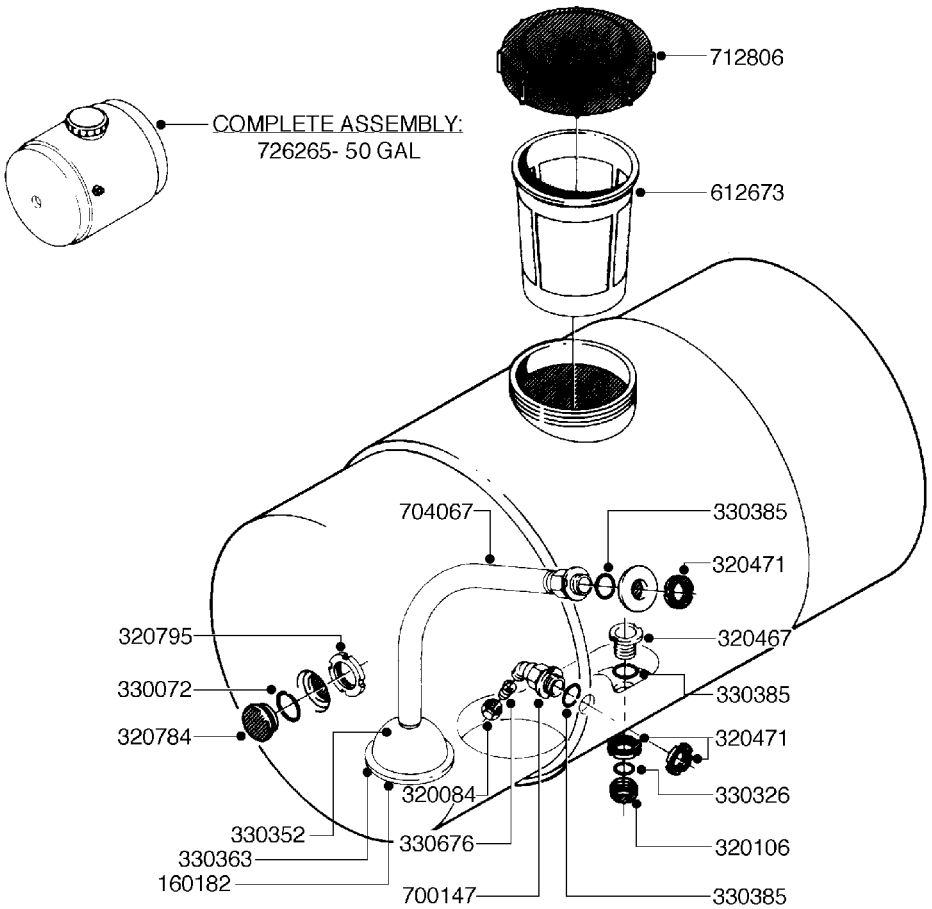



M70 CONTROL

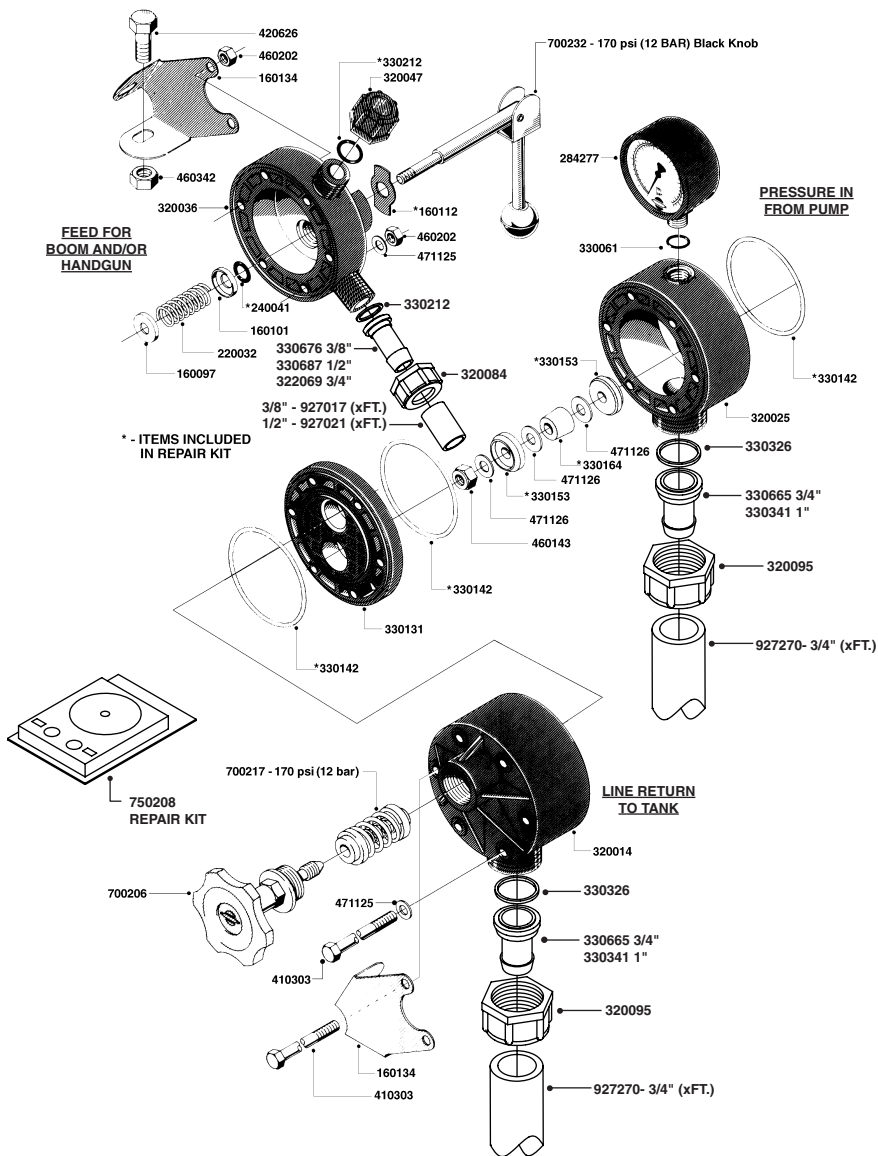



500 PUMP

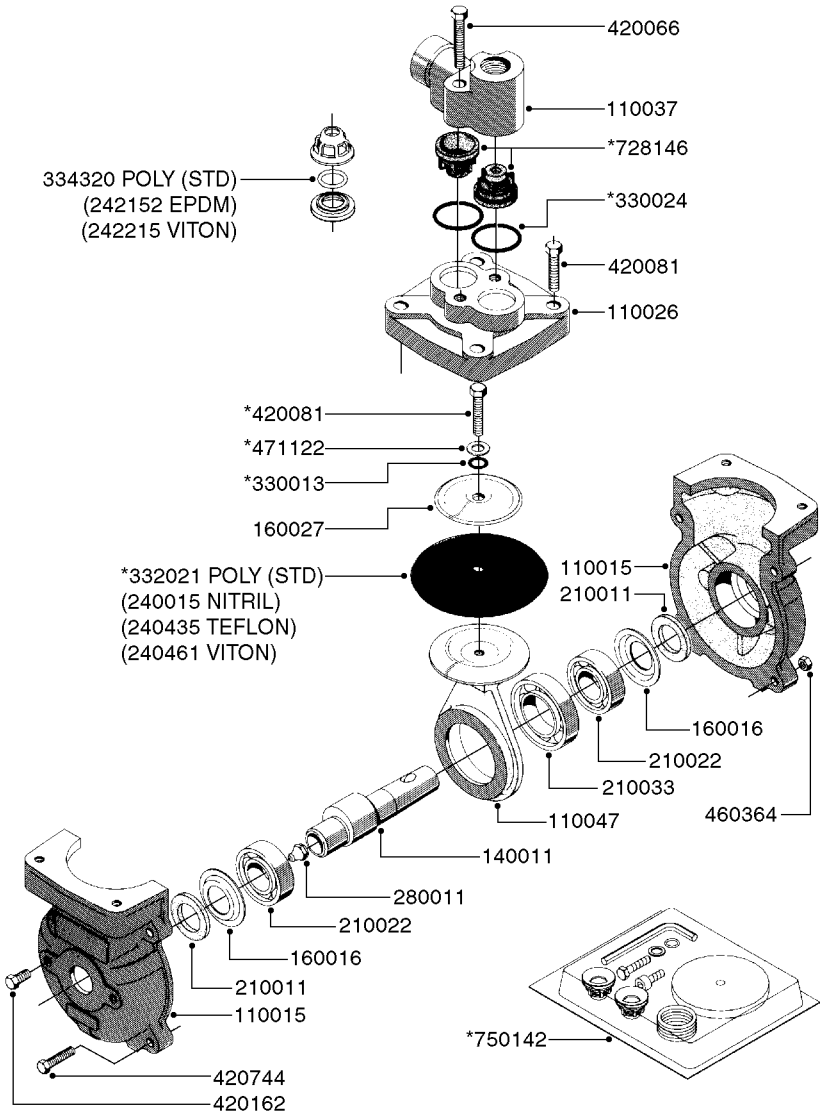



PUMP FITTINGS

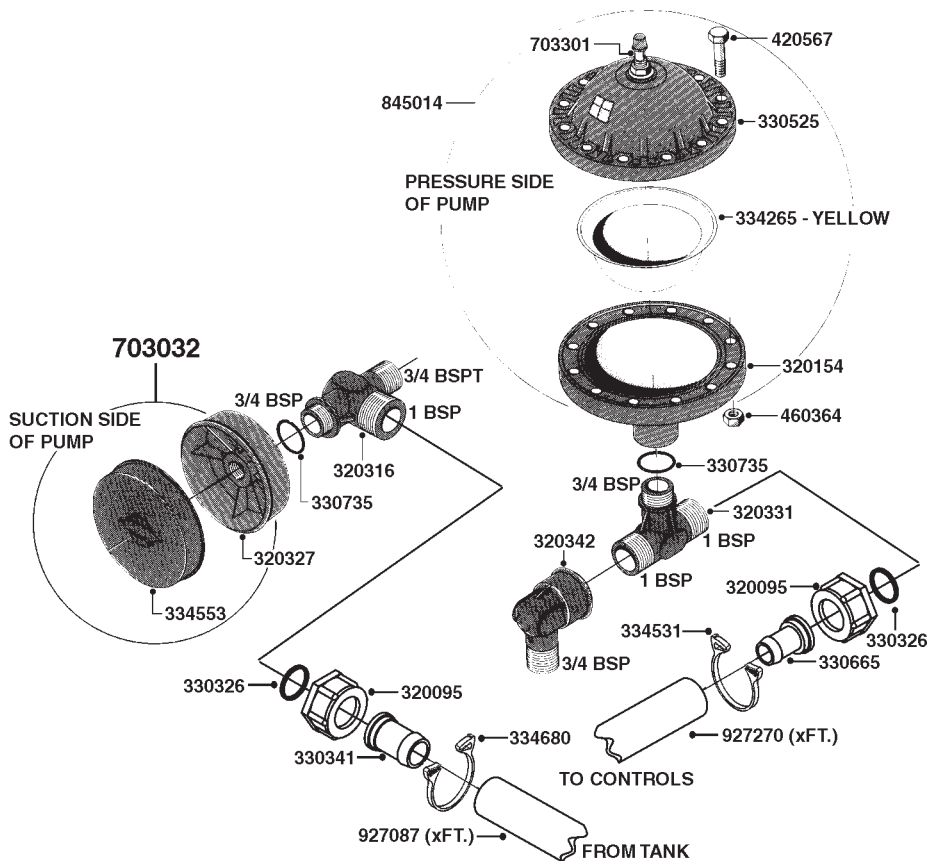



14' HD BOOM

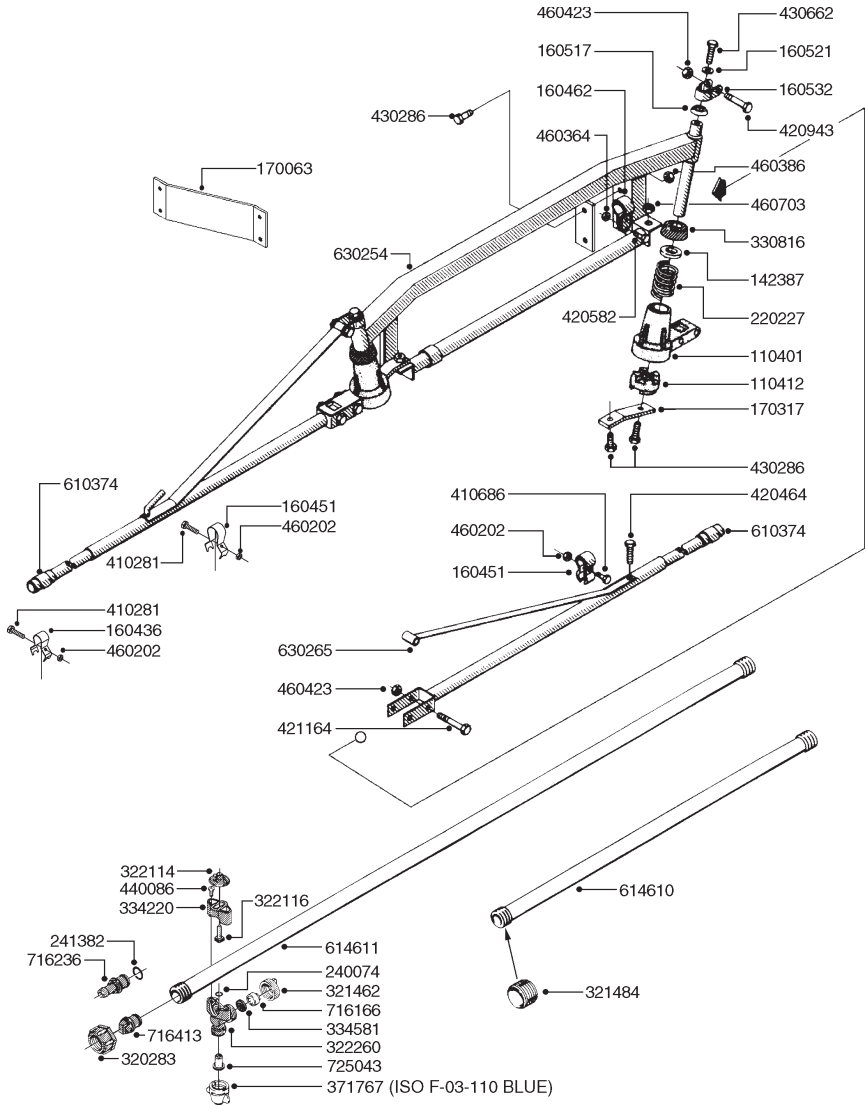

SPRAYGUN

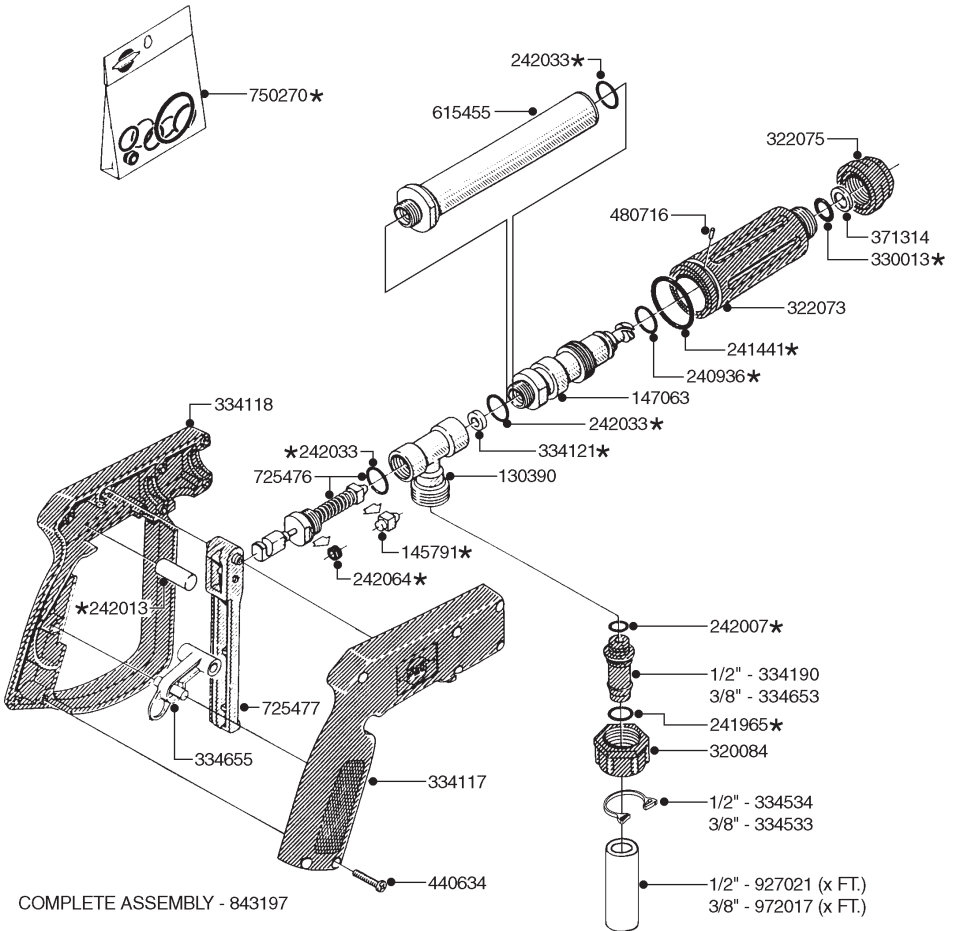



VS 8 BERRY BOOM

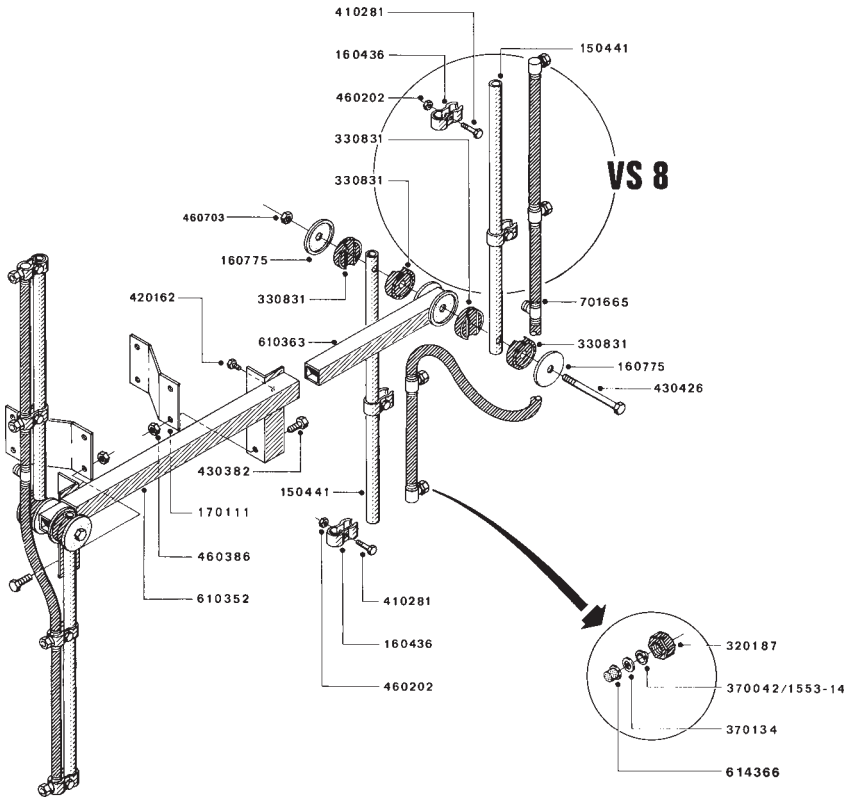

V-II BERRY BOOM

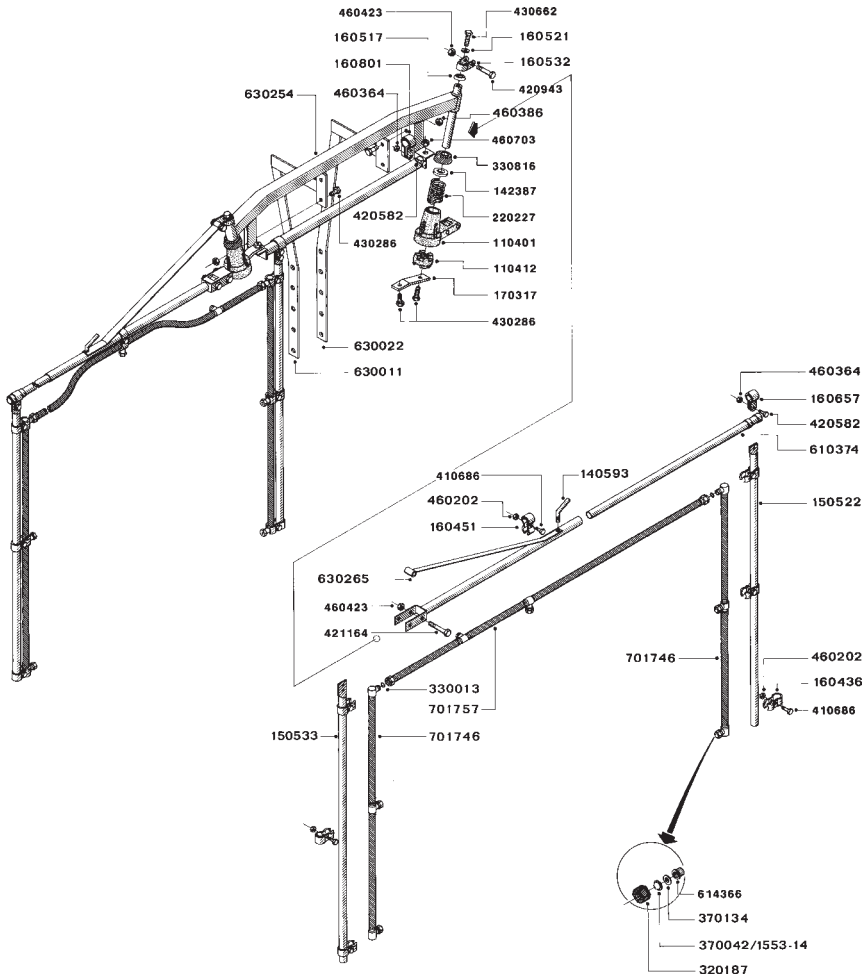



PTO SHAFT, BONDOLI

COMPLETE PTO - 829482

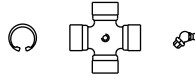

289042

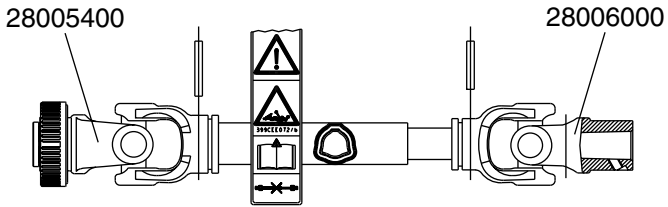

28008500

28007500

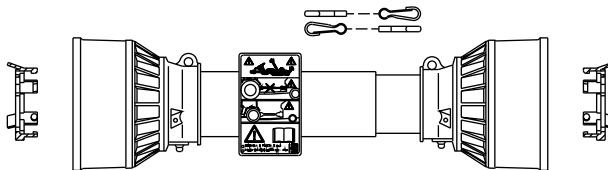

28008600

12.0 WARRANTY POLICY AND CONDITIONS



HARDI® INC. , 1500 West 76th Street, Davenport, Iowa USA; 5646 W. Barstow, Fresno, California, USA; and 290 Sovereign Road, London, Ontario, Canada hereinafter called "HARDI®", offers the following limited warranty in accordance with the provisions below to each original retail purchaser of HARDI® new equipment of its own manufacturer, from an authorized HARDI® dealer, that such equipment is at the time of delivery to such purchaser, free from defects in material and workmanship and that such equipment will be warranted for a period of one year from the date of delivery to the end user providing the machine is used and serviced in accordance with the recommendations in the Operator's Manual and is operated under normal farm conditions.

1. This limited warranty is subject to the following exceptions:
 - a) Parts of the machine not manufactured by HARDI®, (i.e. engines, tires, tubes, electronic controls, and other components or trade accessories, etc.) are not covered by this warranty but are subject to the warranty of the original manufacturer. Any claim falling into this category will be taken up with the manufacturer concerned.
 - b) This warranty will be withdrawn if any equipment has been used for purposes other than for which it was intended or if it has been misused, neglected, or damaged by accident, let out on hire or furnished by a rental agency. Nor can claims be accepted if parts other than those manufactured by HARDI® have been incorporated in any of our equipment. Further, HARDI® shall not be responsible for damage in transit or handling by any common carrier and under no circumstances within or without the warranty period will HARDI® be liable for damages of loss of use, or damages resulting from delay or any consequential damage.
2. We cannot be held responsible for loss of livestock, loss of crops, loss because of delays in harvesting or any expense or loss incurred for labor, supplies, substitute machinery, rental for any other reason, or for injuries either to the owner or to a third party, nor can we be called upon to be responsible for labor charges, other than originally agreed, incurred in the removal or replacement of components.
3. The customer will be responsible for and bear the costs of:
 - a) Normal maintenance such as greasing, maintenance of oil levels, minor adjustments, etc.
 - b) Transportation of any HARDI® product to and from where the warranty work is performed.
 - c) Dealer travel time to and from the machine or to deliver and return the machine from the service workshop for repair.
 - d) Dealer traveling costs.
4. Parts defined as normal wearing items, (i.e. tires and V-belts) are not in any way covered under this warranty.
5. This warranty will not apply to any product which is altered or modified without the express written permission of HARDI® and/or repaired by anyone other than an Authorized Service Dealer.
6. Warranty is dependent upon the strict observance by the purchaser of the following provisions:
 - a) That this warranty may not be assigned or transferred to anyone.
 - b) That the Warranty Registration Certificate has been correctly completed by dealer and purchaser with their names and addresses, dated, signed and returned to the appropriate address as given on the Warranty Registration Certificate.
 - c) That all safety instructions in the operators manual shall be followed and all safety guards regularly inspected and replaced where necessary.



7. No warranty is given on second-hand products and none is to be implied.
8. HARDI® reserves the right to incorporate any change in design in its products without obligation to make such changes on units previously manufactured.
9. Subject to the following terms, conditions and contributions, HARDI® extends the warranty on polyethylene tanks (excluding fittings, lids and gaskets) to FIVE YEARS. To qualify for this extended warranty, the tank must be drained and flushed with fresh water after each day of use. HARDI®'s liability is limited to replacement of the tank, FOB our plant at no cost to the purchaser during the first twelve months; at 20% of the then current price during the second year; at 40% during the third year; at 60% during the fourth year; and at 80% during the fifth year. This five year extended warranty is subject, in each instance, to the tank being inspected and approved for replacement or repair by HARDI® personnel before HARDI® will accept any liability hereunder.
10. Subject to the following terms, conditions, contributions, HARDI® extends the warranty on HARDI® diaphragm pumps (excluding wearing parts such as diaphragms, valves, etc.) to FIVE YEARS. To qualify for this extended warranty, the pump must be drained and flushed with fresh water after each day of use. HARDI®'s liability is limited to replacement of defective parts, FOB our plants in Davenport, Iowa, USA and London, Ontario, Canada at no cost to the purchaser during the first twelve months after date of purchase, at 20% of the then current retail price during the second year; at 40% during the third year; at 60% during the fourth year; and at 80% during the fifth year. This five year extended warranty is subject, in each instance, to the pump being inspected and approved for replacement or repair by HARDI® personnel before HARDI® will accept any liability hereunder.
11. The judgement of HARDI® in all cases of claims under this warranty shall be final and HARDI® conclusive and the purchaser agrees to accept its decisions on all questions as to defect and to the exchange of any part or parts.
12. No employee or representative is authorized to change this warranty in any way or grant any other warranty unless such change is made in writing and signed by an officer of HARDI® at its head office.
13. Any warranty work performed which will exceed \$400.00 MUST be approved IN ADVANCE by the Service Manager.
14. Any pump replacement must be approved in advance by the Service Manager.
15. Claims under this policy must be filled with HARDI® within thirty (30) days of work performed or warranty shall be void.
16. Parts requested must be returned prepaid within thirty (30) days for warranty settlement.
17. Warranty claims must be COMPLETELY filled out properly or will be returned.

DISCLAIMER OF FURTHER WARRANTY

THERE ARE NO WARRANTIES, EXPRESSED OR IMPLIED, EXCEPT AS SET FORTH ABOVE. THERE ARE NO WARRANTIES WHICH EXTEND BEYOND THE DESCRIPTION OF THE PRODUCT CONTAINED HEREIN. IN NO EVENT SHALL THE COMPANY BE LIABLE FOR INDIRECT, SPECIAL OR CONSEQUENTIAL DAMAGES (SUCH AS LOSS OF ANTICIPATED PROFITS) IN CONNECTION WITH THE RETAIL PURCHASER'S USE OF THE PRODUCT.