



**NAVIGATOR
550M, 800M, 1000M Centrifugal
Operator's Manual**

10613903 (8/04)

HARDI® reserves the right to make changes in design, material, or specification without notice thereof. HARDI® and other product names are registered trademarks of HARDI® Inc. in the U.S. and in other countries.



TABLE OF CONTENTS

1.0 INTRODUCTION	6
2.0 SAFETY INFORMATION	7
2.1 Follow Safety Instructions	8
2.2 Operating the Sprayer Safely	8
2.3 Handling Chemical Products Safely	10
2.4 Local Poison Information Center	11
3.0 HOOKING UP THE SPRAYER	12
3.1 Clevis Hitch	12
3.2 Wheel Spacing and Ground Clearance	12
3.3 Hydraulic Driven Centrifugal Pump	14
3.4 P.T.O. Shaft Operator Safety (P.T.O. Driven Pumps Only)	15
3.5 Installation Of P.T.O. Shaft (P.T.O. Driven Pumps Only)	16
3.6 Hydraulic Requirements	17
3.7 Control Box For ESC Control Unit	18
4.0 OPERATING INSTRUCTIONS	19
4.1 Operating the Boom	19
4.2 Filling The Main Tank	19
4.3 Filling The Flush Tanks (If fitted)	19
4.4 Manifold Sprayer Plumbing Diagram	20
4.5 Manifold System	20
4.6 Manifold Operating Instructions	22
4.7 Operation of Centrifugal Bypass Kit (Early models only)	23
4.8 Adjustment Of the ESC Controls	24
4.9 Adjustment of Constant Pressure	25
4.10 Agitation Adjustment (Agitation Nozzles Only)	26
4.11 Adding Chemicals	27
4.12 Use of Flush Tank and Rinse Nozzles (optional)	32
4.13 Operation Of The Tank Drain Valve	34
4.14 Nozzle Selection	35
4.15 Calibration	38
5.0 MAINTENANCE	42
5.1 Cleaning The Sprayer	42
5.2 Filters	44
5.3 Recommended Tire Pressure	45
5.4 Wheel Nuts and Bearings Adjustment	45



5.5	Tandem Axles	46
5.6	Nozzle Tubes And Fittings	47
5.7	Checking the Valve Cone in Distribution Valves . . .	48
5.8	Hydraulic Driven Pump Repair Parts	48
5.9	P.T.O. Belt Driven Pump Repair Parts	49
5.10	Emergency Operation Of ESC Controls	50
5.11	Level Indicator	50
5.12	Lubrication	51
6.0	OFF-SEASON STORAGE	54
6.1	Preparation After Off-Season Storage	55
7.0	ACCESSORIES	56
7.1	Clean Water Dispenser	56
7.2	Chemical Filler (optional)	56
7.3	Chemical Filler Bag & Bottle Rinse Kit (optional) . .	57
7.4	Nurse Tank Quick Fill (optional)	57
7.5	Foam Marker System (optional)	58
7.6	4" Boom Pressure Gauge (optional)	59
7.7	Flush System (optional)	59
7.8	Tank Rinse System (optional)	60
7.9	Spraygun And Hose wrap (optional)	61
7.10	HARDI® Monitor 1500 (optional)	61
7.11	HARDI® Controller 2500 (optional)	62
7.12	Mustang 3500 Controller (optional)	62
8.0	TROUBLESHOOTING	63
8.1	General Spray Systems	63
8.2	Foam Marker	65
8.3	Flush & Rinse™	66
8.4	Chemical Filler	66
9.0	WARRANTY POLICY AND CONDITIONS	67



Dear Owner,

Thank you for purchasing a HARDI® product and welcome to the ever-increasing family of HARDI® sprayer owners.

Our sprayers and accessories are rapidly becoming a familiar sight on North American farms. We believe that this results from growers becoming increasingly conscious of crop protection input costs and the vital need for cost effective application equipment.

Please take the time to thoroughly read the Operator's Manual before using your equipment. You will find many helpful hints as well as important safety and operation information.

Some of the features on your HARDI® NAVIGATOR Manifold sprayer were suggested by growers. There is no substitute for "on farm" experience and we invite your comments and suggestions. If any portion of this instruction book remains unclear after reading it, contact your HARDI® dealer or service personnel for further explanation before using the equipment.

For Product, Service or Warranty Information:

- Please contact your local HARDI® dealer.

To contact HARDI® directly:

- Please use the HARDI® Customer Service number: 1-866-770-7063

- Or send your email to CUSTSERV@hardi-us.com

HARDI® INC.

Visit us online at: www.hardi-us.com

HARDI® MIDWEST
1500 West 76th St.
Davenport, Iowa 52806
Phone: (563) 386-1730
Fax: (563) 386-1710

HARDI® GREAT LAKES
290 Sovereign Rd.
London, Ontario N6M 1B3
Phone: (519) 659-2771
Fax: (519) 659-2821

HARDI® WEST COAST
8550 W. Roosevelt Avenue
Visalia, California 93291
Phone: (559) 651-4016
Fax: (559) 651-4160

Sincerely,

Tom L. Kinzenbaw
President



Fig. 1

Navigator HC 550M Centrifugal w/ Eagle™ Boom



1.0 INTRODUCTION

The HARDI® Navigator 550M, 800M* and 1000M centrifugal models consist of a hydraulic pump or P.T.O. driven pump with P.T.O. shaft, frame with tank, ESC controls (Electric Control) and Manifold System. The Navigator 550M model is available with either the hydraulic folding Eagle™ SPB series spray boom available in 45', 50', 60' or 66' widths or a manual fold boom (MB) available in 35', 40', 42', 45' or 50' widths. The Navigator 800M*/1000M model is available with the hydraulic folding Eagle™ SPC series spray boom available in 80' 88' or 90' widths.

The tanks, made of impact proof and chemical resistant polyethylene, have a purposeful design with rounded contours which allows for efficient cleaning and draining. The tanks are designed with a large deep sump, so that they can be completely emptied even when the sprayer is used on slopes up to 15% inclination. A remote operated valve drain is fitted for efficient draining.

The ESC control unit consists of: ON/OFF control, pressure regulating valve, 2 1/2" pressure gauge and distribution valves with pressure equalization.

The "Manifold System" features color coded three way valves on suction and pressure sides of the liquid control system. It allows for safe and simple use of the sprayer and accessories from one centralized location.

The Eagle™ coil spring suspended hydraulic series boom is available with either 3 (HY model) or 5 (HZ model) hydraulic cylinders. The base version being the HY model, includes boom height adjustment and fold/unfold features all controlled from the tractor. The HZ model has all the same features as the HY model but also includes individual wing tilt and fold with a 'joystick' control handle. An optional electrical 'DH' control for closed center hydraulics is available. Both versions require single and double acting hydraulic outlets on the tractor as well as a 12V connection for the HZ model. The MB (manual fold boom) offers hydraulic height adjustment and hydraulic wing tilt as options.

*The Navigator 800M is no longer available

2.0 SAFETY INFORMATION



WARNING



**ALWAYS READ OPERATOR'S MANUAL BEFORE
USING EQUIPMENT**

**DO NOT REMOVE ANY SAFETY DEVICES OR
SHIELDS. NEVER SERVICE, CLEAN OR REPAIR A
MACHINE WHILE IT IS OPERATING**

WARNING



**ALWAYS WATCH FOR THIS SYMBOL TO POINT OUT
IMPORTANT SAFETY PRECAUTIONS**

**IT MEANS ATTENTION! BECOME ALERT!
YOUR SAFETY IS INVOLVED!**



RECOGNIZE SAFETY INFORMATION



This is the Safety-alert symbol. When you see this symbol on your machine or in this manual, be alert to the potential for personal injury.

Follow recommended precautions and safe operating practices.

2.1 Follow Safety Instructions

- Carefully read all the safety messages in this manual and the safety labels fitted to the machine. Keep safety labels in good condition. Replace missing or damaged safety labels. Be sure that new equipment components include any current safety labels. Replacement safety labels are available from your authorized HARDI® dealer.
- Learn how to operate the sprayer and how to use the controls properly. Do not let anyone operate the machine without proper instructions.
- Keep your sprayer in proper working condition. Unauthorized modifications or use may impair the function and/or safety and affect the machine's life.
- If you do not understand any part of this manual and need assistance, please contact your authorized HARDI® dealer.

2.2 Operating The Sprayer Safely

1. Read the complete manual carefully and become familiar with the operation of the equipment before initial operation in each spraying season. Failure to do so may result in possible over or under application of spray solution which may drastically affect crop production and lead to personal injury.
2. Before starting the engine on the tractor unit, be sure all operating controls are in the off or neutral position, including (but not limited to) the hydraulic lever to operate the hydraulic driven pump, the P.T.O. shaft and/or spray controls. Be sure the tractor power train is disengaged.
3. Operate spray and boom functions only when seated in the operator's seat.



4. One of the most frequent causes of personal injury or death results from persons falling off or being run over. Do not permit others to ride on or in. Only one person should be working the machine when in operation.
5. Before leaving the tractor seat, stop the engine, put all controls in neutral, and put the transmission control lever in the park position or neutral with the brakes locked. Read the tractor operations manual for added safety precautions.
6. P.T.O. driven equipment can cause serious injury. Before working on or near the P.T.O. shaft, servicing or cleaning the equipment, put P.T.O. lever in the DISENGAGE position and stop the engine.
7. Do not fold or unfold boom near overhead wires. Serious injury or death could result if contact is made with electric wires.
8. Keep hands, feet & clothing away from moving parts.
9. Wear relatively tight and belted clothing to prevent from being caught on some part of the machine.
10. Slow down when turning, especially with boom unfolded.
11. Always keep children away from your sprayer and/or tractor unit.
12. Before transporting the sprayer, ensure that the boom is fully folded and fully locked into transport position. Ensure all locking devices are fully engaged, whether hydraulic or mechanical.
13. Slow moving tractors and spray equipment can create a hazard when on public roads. Avoid personal injury or death resulting from any accidents by using flashing lights. Local regulations may require installation of flashing warning lights.
14. Avoid injuries from high pressure fluids penetrating the skin by relieving system pressure before disconnecting hydraulics or other lines. Ensure all fittings are tight before applying pressure to the system.
15. Understand service procedures before undertaking any maintenance. Never lubricate, service, or adjust the machine while it's moving. Securely support any components before working on them.
16. Keep all parts in good condition and properly installed. Fix damaged parts immediately. Replace worn or broken parts. Remove excessive buildup of grease, oil or debris.



2.3 Handling Chemical Products Safely

1. Direct exposure to hazardous chemicals can cause serious injury. These chemicals can include lubricants, coolants, paints, adhesives and agricultural chemicals. Material Safety Data Sheets (M.S.D.S.) are available for all hazardous chemicals which inform the user of specific details including: physical and health hazards, safety procedures, and emergency response techniques.
2. Protective clothing such as rubber gloves, goggles, coveralls and respirator must be worn while handling chemicals. All protective clothing should be kept in excellent condition and cleaned regularly or discarded.
3. If chemicals come in contact with any exposed skin areas, wash immediately with clean water and detergent. Never place nozzle tips or any other components that have been exposed to chemicals to lips to blow out obstructions. Use a soft brush to clean spray nozzles.
4. Dedicate an area to fill, flush, calibrate and decontaminate sprayer where chemicals will not drift or run off to contaminate people, animals, vegetation, water supply, etc. Locate this area where there is no chance of children coming in contact with this residue.
5. Decontaminate equipment used in mixing, transferring and applying chemicals after use. Follow the instructions on the chemical label for the correct procedure required. Wash spray residue from outside of the sprayer to prevent corrosion.
6. Extreme care should be taken in measuring spray products. Powders should be used in suitable sized packages or weighed accurately. Liquids should be poured into a suitable graduated container. Keep chemical containers low when pouring. Wear a filtered respirator and let the wind blow away from you to avoid dust and/or splashes contacting the skin or hair.
7. Store chemicals in a separate, plainly marked locked building. Keep the chemical in its original container with the label intact.
8. Dispose all empty containers after rinsing in accordance with local regulations & by-laws. Dispose of all unused chemicals and left over fertilizer in an approved manner
9. Keep a first aid kit and fire extinguisher available at all times when handling chemicals.

2.4 Local Poison Information Center

If you live anywhere in the United States, the following toll free number will connect you to your Local Poison Information Center.



PHONE NO. 1 - 8 0 0 - 2 2 2 - 1 2 2 2

If you live outside the United States, find the number for the poison control center in your phone book and write it in the space below:

PHONE NO. _____ - _____ - _____

Keep a list, in the space provided below, of all the chemicals that you have in use.

1. _____
2. _____
3. _____
4. _____
5. _____
6. _____
7. _____
8. _____
9. _____
10. _____

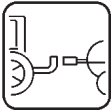

3.0 HOOKING UP THE SPRAYER

3.1 Clevis Hitch

WARNING: THE TRAILER TONGUE MUST BE ADEQUATELY SUPPORTED AND WHEELS BLOCKED BEFORE ADJUSTING CLEVIS HITCH POSITION.

Adjusting the height of the clevis is obtained by removing the four bolts and repositioning the clevis in one of the eight different settings (Fig. 2). This will allow for 13" of adjustment to suit tractor drawbar height and to maintain the sprayer tank level.

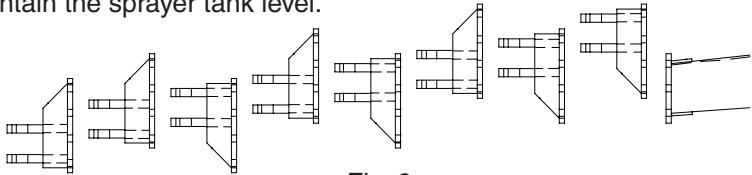

*Fig. 2
Adjusting The Clevis Hitch*

3.2 Wheel Spacing And Ground Clearance

WARNING: SECURELY SUPPORT THE SPRAYER DURING AXLE ADJUSTMENTS. NEVER ATTEMPT TO ADJUST AXLES WITH LIQUID IN TANK. ALWAYS BLOCK WHEELS ON OPPOSITE SIDE WHEN ADJUSTING AXLES.



The wheel spacing of the trailer can be set according to the table below:

Wheel Spacing & Clearance Table

Model	Wheel Spacing	Axle Clearance
STA 550M	60" - 88"	26"
HC 550M (24" tire)	60" - 88"	18"
HC 550M (38" tire)	60" - 88"	24"
TA 800M/1000M*	60" - 88" and 120"	20 / 27.5"
HC 800M/1000M (38" tire)	72" - 88" and 120"	26"
HC 800m/1000M (42" tire)	72" - 88" and 120"	27.5"

To adjust the width, remove the four bolts per side (A) (Fig. 3) and the axle assemblies can then be pushed in or pulled out in 2" increments until the required wheel tread is obtained. Then reinstall and refasten all bolts.



WARNING: IT IS NOT PERMITTED TO FIT DUAL WHEELS TO ANY OF THE AXLES ON THE NAVIGATOR M. SPRAYER MODELS.

*No longer available

Note: On 550M HC models, rims may have to be switched from one side to the other to obtain proper wheel spacing.

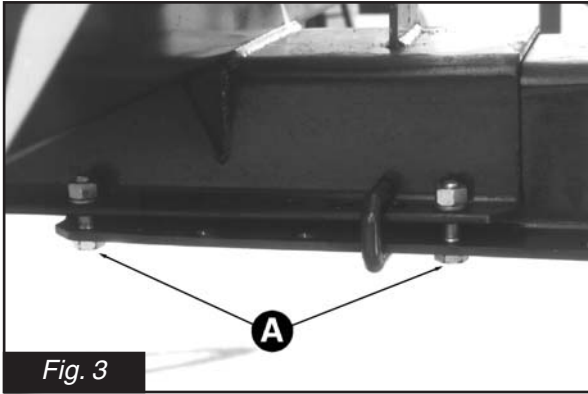
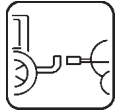

Ground clearance can be changed on the 800M/1000M TA (no longer available) to either 20" or 27.5". This is done by loosening the three bolts **(B)** (Fig. 4) and removing the pivot pin. Place the tandem beam at either of the two positions and reinstall the pivot pin and bolts.

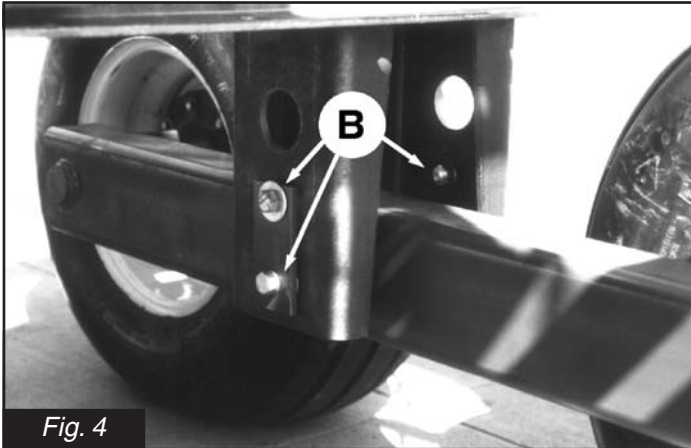

Note: The HARDI® Navigator 800M/1000M model also has an optional 120" wide axle. The 120" axle is available in the single axle HC (High Clearance). The TA (Tandem Axle) version is no longer available. The 120" axle is a fixed length and cannot be adjusted. Ground clearance is the same as the standard axle systems.

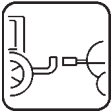

3.3 Hydraulic Driven Centrifugal Pump

WARNING: IF YOU ARE UNSURE OF THE TYPE OF TRACTOR HYDRAULIC SYSTEM YOU HAVE, CONSULT THE HYDRAULIC SYSTEM PUMP GUIDE AND/OR FOLLOW THE HARDI® INSTALLATION SHEET (PART NO. #105873) SUPPLIED WITH YOUR SPRAYER. FAILURE TO DO SO CAN CAUSE SERIOUS DAMAGE TO YOUR TRACTOR HYDRAULICS AND/OR THE PUMP.

1. Connect 3/8" or 1/2" hydraulic lines with 3/8" NPT ends to the hydraulic motor.
2. Connect the pressure line **(A)** (Fig.5), IN port, to the tractor outlet port.
3. Connect the return line **(B)** (Fig. 5), OUT port, from the motor to the low pressure return line on the tractor. Failure to do so may cause the hydraulic motor seal to blow.

Note: If a low pressure return is not available, consult your tractor dealer.

4. Open the suction valve coming from the sump of the sprayer tank.
5. Bleed out all the air in the suction line by removing the plug **(C)** (Fig. 5) on the top rear side of the pump and wait until there is a full stream of fluid coming out. Reinstall the plug.

Note: Running the centrifugal pump dry for longer than 3 seconds will cause serious damage to the pump seal.

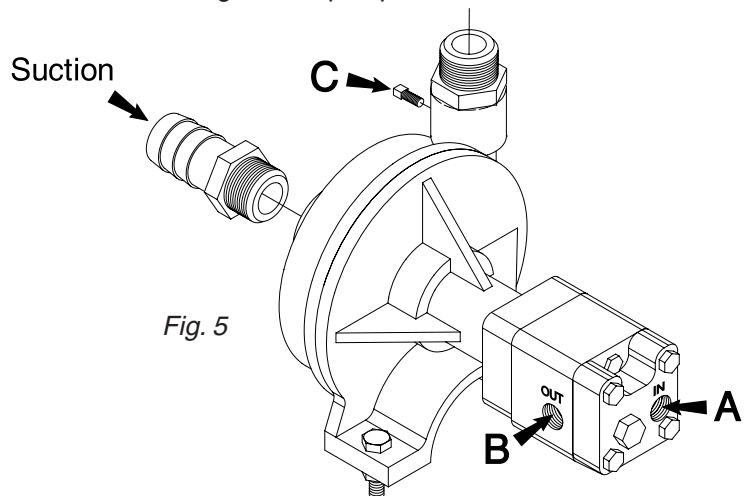

Fig. 5

3.4 P.T.O. Shaft Operator Safety (P.T.O. Driven Pumps Only)

WARNING: ALWAYS STOP ENGINE BEFORE ATTACHING THE TRANSMISSION SHAFT TO TRACTOR P.T.O. - MOST TRACTOR P.T.O. SHAFTS CAN BE ROTATED BY HAND TO FACILITATE SPLINE ALIGNMENT, WHEN ENGINE IS STOPPED.

When attaching the shaft, make sure that the snap lock is FULLY ENGAGED - push and pull shaft until it locks.

WARNING: ROTATING TRANSMISSION SHAFTS WITHOUT PROTECTION GUARDS ARE FATAL.

Always keep protection guards and chains intact and make sure that it covers all rotating parts, including CV-joints at each end of the shaft. Do not use without protection guard.

Do not touch or stand on the transmission shaft when it is rotating - safety distance: min 5' (1.5 meters).

Prevent protection guards from rotating by attaching the chains allowing sufficient slack for turns.

Make sure that protection guards around tractor P.T.O. and implement shaft are intact. Check every 40 hours.

Always **STOP ENGINE** and remove the ignition key before carrying out maintenance or repairs to the transmission shaft or implement.

Make sure that belt guards on belt-driven pumps are intact. Never operate without belt guards.

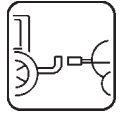
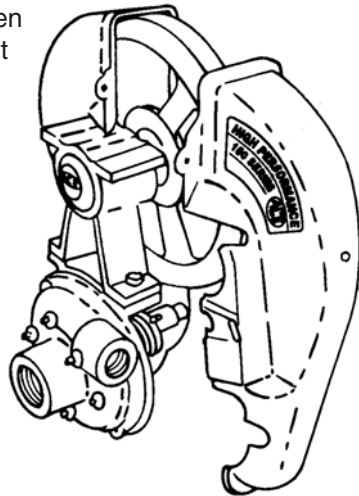

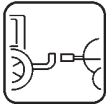

3.5 Installation Of P.T.O. Shaft (P.T.O. Driven Pumps Only)

WARNING: THE P.T.O. SHAFT ANGLE WILL CHANGE WHEN RAISING AND LOWERING THE AXLE SYSTEMS AND/OR CLEVIS. TO PREVENT EXCESSIVE LOADING AND BINDING ON THE P.T.O. SHAFT, IT MAY BE ADVISABLE TO LEAVE THE P.T.O. SHAFT DISCONNECTED UNTIL THIS OPERATION IS COMPLETED. THEN THE P.T.O. SHAFT ADJUSTMENTS CAN BE MADE.

Initial installation of the shaft is done as follows:

1. Attach sprayer to tractor and set sprayer in the position with **shortest** distance between the tractor and sprayer pump P.T.O. shafts.
2. Stop engine and remove ignition key.
3. If P.T.O. shaft must be shortened, the shaft is pulled apart. Fit the two shaft parts at tractor and sprayer pump and measure how much it is necessary to shorten the shaft. Mark the protection guards.

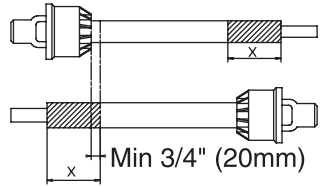

Note: The minimum allowable overlap for the shaft depends on the pump model.

Pump with 6 splines (540 r.p.m.)

The shaft must always have a minimum overlap of 1/3 the length.

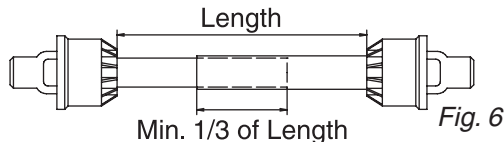

Pump with 21 splines (1000 r.p.m.)

The shaft must always have a minimum overlap of 2/3 the length.

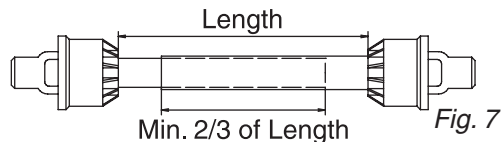

4. The two parts are shortened equally. Use a saw, and file the profiles afterwards to remove burrs (Fig. 8).

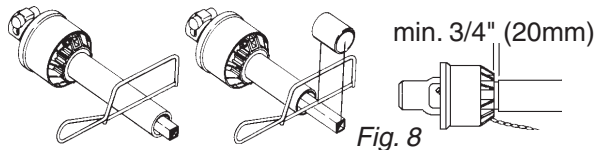

5. Grease the profiles, and assemble male and female parts again.
6. Fit the shaft to tractor and sprayer pump.

Note: Female part towards tractor. Fit the chains to prevent the protection guards rotating with the shaft.

7. To ensure long life of the P.T.O. shaft, try to avoid working angles greater than 15° (Fig. 9).

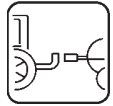
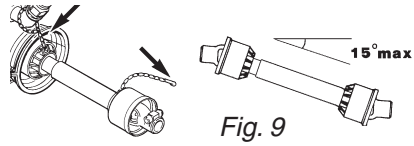

3.6 Hydraulic Requirements

Eagle™ Boom:

Hydraulic booms need one single outlet for the lift function of the spray boom and one double outlet for the folding function. Note that the hydraulic system requires an oil capacity of approximately .8 GPM (3 LPM) and a minimum pressure of 1,950 PSI (130 bar).

Hydraulic Driven Centrifugal Pump:

The pump motor needs one single outlet and a low pressure return outlet on the tractor.

Note: The hydraulic driven pump system requires an oil capacity of 7 GPM (26.5 LPM) and a minimum pressure of 1000 PSI (67 bar).

BE SURE TO HOOK UP HYDRAULIC LINES PROPERLY!

ENSURE HYDRAULIC LINES HAVE NOT BEEN DAMAGED DURING SHIPPING.

ESCAPING HYDRAULIC FLUID UNDER PRESSURE CAN PENETRATE THE SKIN CAUSING SERIOUS INJURY. AVOID THIS HAZARD BY RELIEVING PRESSURE BEFORE DISCONNECTING HYDRAULIC LINES.

ENSURE ALL CONNECTIONS ARE TIGHT BEFORE APPLYING PRESSURE, SEARCH FOR LEAKS WITH A PIECE OF CARDBOARD, NOT YOUR HANDS!

IMPROPER HOOK-UP CAN CAUSE DANGEROUS BOOM MOVEMENTS AND/OR DAMAGE TO THE SPRAYER HYDRAULICS.

DO NOT ALLOW ANYONE NEAR A HYDRAULIC BOOM IN OPERATION.

ALWAYS SHUT TRACTOR OFF WHEN CONNECTING, SERVICING OR ADJUSTING BOOM.



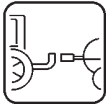

Hydraulic Hook-up For Booms

1. Attach the heavier (3/8") hydraulic hose for the boom lift to the tractor's single acting outlet.

Note: Required on both Eagle™ booms & MB (HL) booms.

2. Attach the lighter (1/4") hydraulic hoses for boom folding & HZ tilt to the tractor's double acting outlet.

3.7 Control Box For ESC Control Unit

The control box for the ESC control unit should be mounted at a convenient place in the tractor cab. The control box has 4 screw holes in the back cover, which need to be drilled out for mounting on a flat surface, use the optional mount kit #728739 if required. There should be a minimum of an 8 amp fuse protecting this circuit.

Power requirement is 12 volt DC.

Note polarity:

Brown pos. (+)

Blue neg. (-)

Use the optional HARDI® Electric 12 volt outlet box #817925 if more than one power outlet is required.



Fig. 10

12-volt junction box for 12-volt hook-up: ESC controls, HARDI® HM1500/HC2500, Foam Marker, Boom Hydraulic Controls, etc.

4.0 OPERATING INSTRUCTIONS

4.1 Operating The Boom

BEFORE UNFOLDING THE BOOM, IT IS IMPORTANT TO HAVE THE SPRAYER HOOKED TO THE TRACTOR TO PREVENT OVERBALANCING THE SPRAYER. ONLY THEN LIFT THE BOOM OFF THE TRANSPORT BRACKETS WHICH HOLD IT IN THE TRANSPORT POSITION.

ENSURE THAT BOOMS ARE IN THE TRANSPORT POSITION BEFORE UNHOOKING THE SPRAYER FROM THE TRACTOR.

THE HYDRAULIC SYSTEM SHOULD BE CHECKED VERY CAUTIOUSLY THE FIRST TIME OF OPERATION; THERE MAY BE AIR IN THE SYSTEM AND THIS COULD CAUSE VIOLENT MOVEMENTS OF THE BOOM. ENSURE THAT NO PERSONS OR OBJECTS ARE IN THE WAY WHILE CHECKING THE SYSTEM.

FOR INFORMATION ON BOOM ADJUSTMENT SEE THE APPROPRIATE BOOM OPERATOR'S MANUAL.

4.2 Filling The Main Tank

Water is filled into the tank by removing the tank lid located at front center of sprayer tank. It is recommended to use water as clean as possible for spraying purposes. Always fill water through the strainer basket to prevent foreign particles from entering the tank.

WARNING: DO NOT LET THE FILLING HOSE ENTER THE TANK. KEEP IT OUTSIDE THE TANK, POINTING TOWARDS THE FILLING HOLE (FIG. 11). IF THE END OF THE HOSE IS BENEATH THE SURFACE OF THE TANK CONTENTS AND THE WATER PRESSURE DROPS AT THE WATER SUPPLY PLANT, CHEMICALS MAY BE SIPHONED BACK AND CONTAMINATE THE WATER SUPPLY LINES.

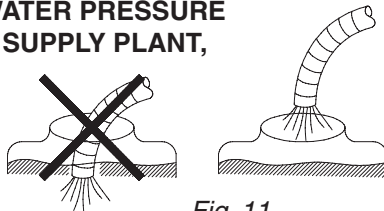
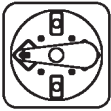

Fig. 11

4.3 Filling the Flush Tank (If fitted)

Remove the tank lid, fill with clean water and replace lid.





4.4 Manifold Sprayer Plumbing Diagram

Review and study the following diagram. By following the flow through the diagram, you will better understand the various functions of your sprayer system.

ESC (with optional equipment)

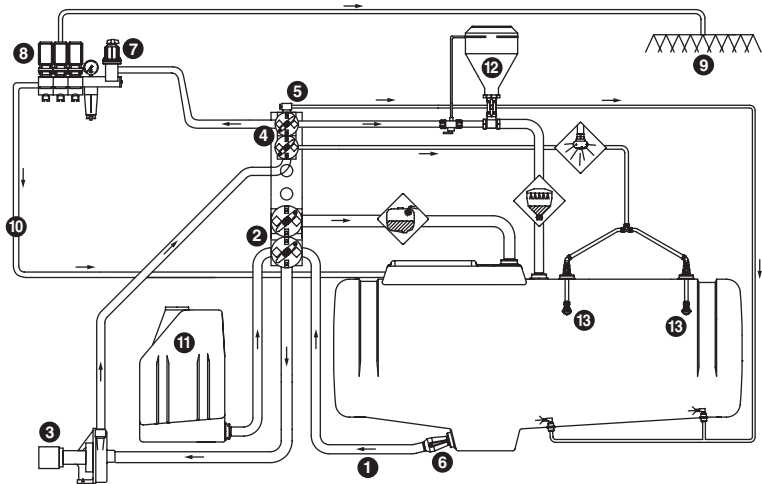

The diagram shows the Standard plumbing with examples of options available.

Function Diagram

- | | |
|------------------------------|----------------------------------|
| 1. Suction line | 8. Distribution valves |
| 2. Suction manifold (black) | 9. Spray boom |
| 3. Pump | 10. Pressure equalization return |
| 4. Pressure manifold (green) | 11. Flush tank* |
| 5. Pressure Agitation | 12. HARDI® chemical inductor* |
| 6. On/Off valve | 13. Tank rinse nozzles* |
| 7. Pressure adjustment | |

*optional equipment

4.5 Manifold System

The “Manifold System” is located at the left hand side of the sprayer, permitting operation of most of the (fitted) accessories from one position.

The modular design of the Manifold system allows the easy addition of many accessories to the plumbing system of the sprayer. The system can be expanded to a maximum of 4 valves on the pressure side and 2 valves on the suction side.

The manifold valve faces are colored discs for easy identification. The green face identifies the pressure manifold, the black disc identifies the suction manifold.



Symbols are fitted to the faces of the 3 way valves indicating the direction of flow of the liquid.

An explanation of the symbols is as follows:



Green Disc = Pressure Valve



• To ESC Control



• To Chemical Filler



• To Hose Reel/Spray Gun



• To Tank Rinsing nozzle Gun



Black Disc = Suction Valve



• Quick Fill



• From Flush Tank



• From Main Tank

A function is activated/opened by turning the handle towards the desired function

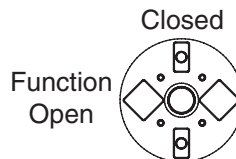



4.6 Manifold Operating Instructions

The green pressure valves and the black suction valves have 4 positions. Two positions are for options. The other two are marked “O” indicating the valve is closed. The arrow on the handle indicates which position is selected.

Green Pressure Valves

To select the optional equipment, the handle is turned so the arrow and thereby liquid is directed to the optional extra instead of the ESC operating unit. When spraying is to resume, turn the handle so the ESC operating unit is selected. The other handles are turned to “O”. If all the green pressure valves are closed, the centrifugal pump will be dead headed.

WARNING: IF THE CENTRIFUGAL PUMP IS DEAD HEADED FOR A LONG PERIOD OF TIME, THE PUMP CAN OVER HEAT AND CAUSE DAMAGE TO THE PUMP SEAL'S.

Black Suction Valves

Turn the handle so the arrow points towards the selected optional equipment (e.g. Flush Tank). To resume suction from the main tank, the arrow must point towards the main tank. Remaining valve must be closed.

Note: The quick fill valve (if fitted) is not connected to the manifold system and is not affected by the operation of the main tank suction valve.

Electric Operated MANIFOLD valves (if fitted)

One or more MANIFOLD valves can be electrically operated via a control box in the tractor cab. In case of an emergency, these can be operated manually only when the 12V power to the valve motor is disconnected first.



*Fig 12
Manifold System Valves*



4.7 Operation of Centrifugal Bypass Kit (Early models only)

The Centrifugal Bypass Kit is designed to improve the priming of the Centrifugal pumps.



1. Before starting the pump, fill the main tank and release any trapped air in the system by holding valve **(A)** (Fig. 13) open for several seconds.

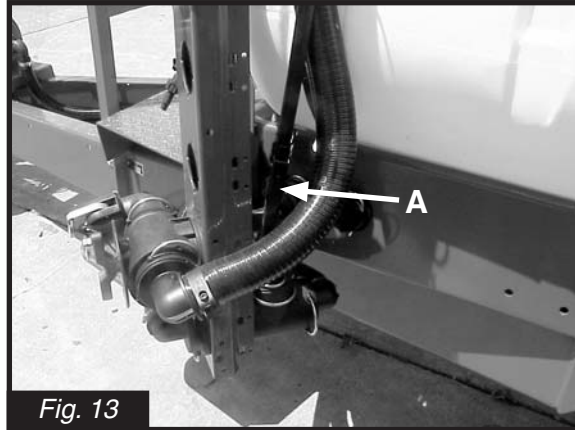

Note: Valves **(A)** and **(B)** are only present when a Centrifugal Bypass Kit has been installed.

2. Flip valve **(B)** (Fig. 14) to the "open" position and then start the pump (See Section 4.8).

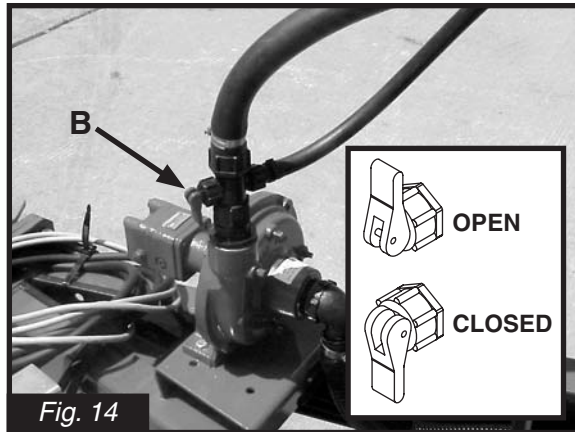

3. Once the pump is "primed", valve **(B)** (Fig. 14) may be closed.



4.8 Adjustment Of The ESC Controls

1. Adjustment screw for constant boom pressure
2. Pressure control valve
3. Distribution valves
4. System pressure gauge
5. System pressure filter

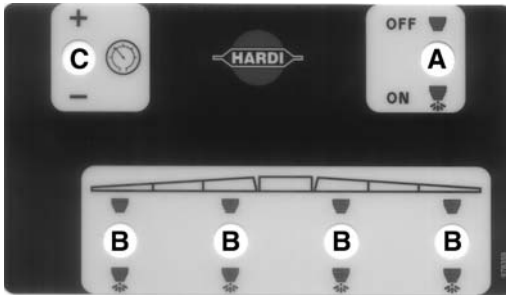
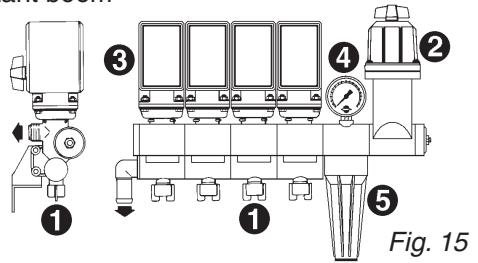

ESC Remote Control Box

- A. Master operating switch for main ON/OFF of boom section valves**
- B. Operating switches for individual ON/OFF of boom section valves**
- C. Pressure control switch to lower or raise nozzle pressure**

1. Choose the correct nozzle (Section 4.14). Make sure that all the nozzles are the same type and capacity.
2. With the tractor in neutral, engage the tractor hydraulic lever (or P.T.O.) to start the pump. Adjust the R.P.M.'s until the number of revolutions corresponds to the intended traveling speed.
3. ON/OFF switch **(A)** (Fig. 16) is "ON" against green symbol.
4. All boom section valve switches **(B)** (Fig. 16) are also "ON" against green symbol.
5. Hold pressure regulating switch **(C)** (Fig. 16) to **(-)** until handle **(2)** (Fig. 15) stops rotating, this will be the "minimum pressure" setting.
6. Hold pressure regulating switch **(C)** (Fig. 16) to **(+)** until desired pressure is shown on the pressure gauge **(4)** (Fig. 15).

4.9 Adjustment of Constant Pressure

Note: Adjust the constant boom section pressure one section at a time as follows: (Start with the valve turned closed before adjusting).



1. Shut-off the first boom section valve switch **(B)** (Fig. 16).
2. Turn the adjusting screw **(1)** (Fig. 15) until the control unit pressure gauge **(4)** (Fig. 15) again shows the same pressure as set in step 6 (Section 4.8). (Turn the screw clockwise for higher pressure, counterclockwise for lower pressure).
3. Turn the boom section valve switch **(B)** (Fig. 16) back on.
4. Repeat steps 1 through 3 for the remaining boom section valves.

Note: Hereafter adjustment of the constant boom pressure will only be needed if you change to nozzles with other capacities, but not required if only changing pressure or application rate using the same nozzles.

5. Operating the control unit while driving: In order to shut off the entire boom, turn ON/OFF switch to "Off" position **(A)** (Fig. 16). This returns all the pump outputs to the tank through the return system. The diaphragm antidrip valves ensures instantaneous closing of all nozzles.

In order to shut off one or more sections of the boom, switch one or more unneeded boom section valves **(B)** (Fig. 16) to "Off" position. The constant pressure device ensures that the pressure does not increase in the sections which are still operating.

In case of electrical failure, it is still possible to manually override all functions of the operating unit. To operate manually, disconnect the multiplug from the ESC control box first and operate the handles by hand. It is possible to change pressure, turn boom sections on or off, or shut off the complete control unit manually.

IMPORTANT: *When the sprayer is stored, the ESC control box and the multiplug must be protected against moisture and dirt. A plastic bag may be used to protect the multiplug. Store the control box in a clean dry place.*

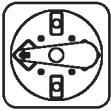

4.10 Agitation Adjustment (Agitation nozzles only)

Agitation is necessary to keep the solution in your tank properly mixed. Consult your chemical supplier for the recommended amount of agitation.

In general, maximum agitation is required but some products tend to foam easily. To reduce foaming in some instances anti-foaming agents may be added to the tank (Refer to chemical label). When running low liquid levels in the tank, agitation may be reduced to facilitate pump priming and avoid pressure fluctuations. Make sure that you have adjusted the agitation properly before sprayer calibration.

Turning the agitation valve **(A)** (Fig. 17) clockwise will reduce the agitation flow. Turning the valve counter clockwise will increase the agitation flow.

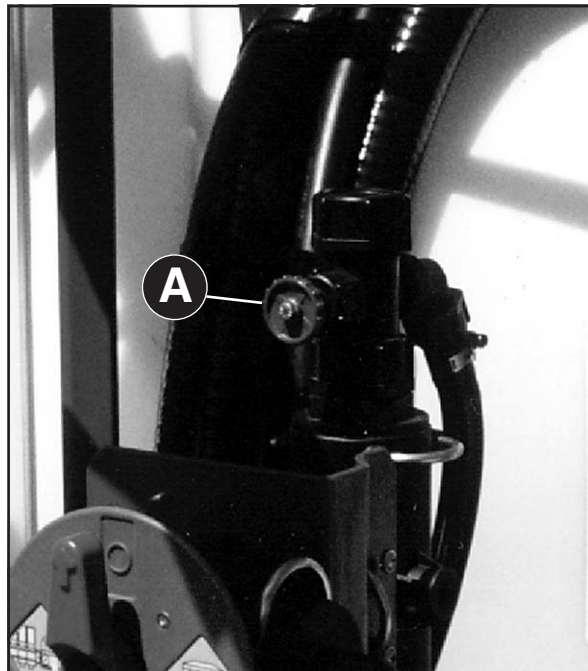

Fig. 17

4.11 Adding Chemicals

Chemicals can be filled into the tank two different ways:

- A. Through the tank lid.
- B. By using the HARDI® CHEMICAL FILLER device.

WARNING: Be careful not to slip or splash chemicals when carrying chemicals up to the tank lid. Always use the personal protection stated on the chemical container and as a minimum, always use gloves, face protection shield and coveralls.

A. Filling through the tank lid

The chemicals are filled through the tank lid - Note instructions on the chemical container!

1. Fill the main tank with clean water, allowing space for the addition of chemicals (See Section 4.2).
2. Make sure the ESC operating unit main on/off switch is in the "Off" position (See Section 4.8).

3. Turn the top green pressure manifold handle to the ESC control symbol.



4. Turn the bottom black suction manifold handle to the Main Tank symbol.



5. Any other manifold valves should be in the "Off" position.
6. Turn the agitation valve (**A**) (Fig. 17) counter clockwise all the way out for maximum agitation.
7. Engage the pump and set P.T.O. revolutions to 540 r.p.m. or 1000 r.p.m. (depending on pump model).
8. Add the chemicals through the main tank hole.
9. When the spray liquid is well mixed, it may be sprayed on the crop. Leave the agitation valve at maximum agitation so the spray liquid is continuously agitated while spraying.







B. Filling with the HARDI® CHEMICAL FILLER (optional)

The HARDI® CHEMICAL FILLER is located directly behind the Manifold System Valves.

Operating with Liquid-based chemicals

1. Make sure the ESC operating unit main on/off switch is in the "Off" position (See Section 4.8).
2. Fill the flush tank (optional) with clean water and fill the main tank at least 1/3 with clean water (unless something else is stated on the chemical container label). (See Sections 4.2, 4.3)
3. Turn the top green pressure manifold handle to the Chem Fill symbol. 
4. Turn the bottom black suction manifold handle to the Main Tank symbol. 
5. Any other manifold valves should be in the "Off" position.
6. Turn the agitation valve **(A)** (Fig. 17) counter clockwise all the way out for maximum agitation.
7. Make sure the bottom valve **(A)** (Fig. 18) is closed on the HARDI® CHEMICAL FILLER.
8. Engage the pump and set P.T.O. revolutions to 540 r.p.m. or 1000 r.p.m. (depending on pump model).
9. Open the HARDI® CHEMICAL FILLER lid.
10. Measure the correct quantity of chemical and fill it into the hopper.

Note: The measuring scale in the hopper can only be used if the sprayer is parked on level ground. It is recommended to use a measuring jug for best accuracy.

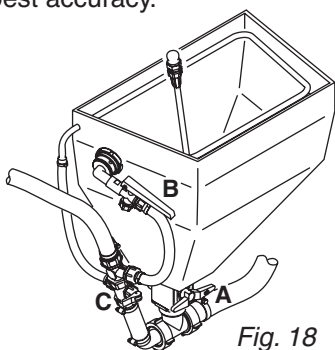

Fig. 18

11. Open the bottom valve **(A)** (Fig. 18) to transfer the chemical to the main tank.
12. If the chemical container is empty, it can be rinsed by using the Bag & Bottle Rinse (optional). Place the container over the multi-hole nozzle and press the lever **(B)** (Fig. 18).

WARNING: Do not press lever (B) (Fig. 18) unless the multi-hole nozzle is covered by a container to avoid spray liquid hitting the operator.

IMPORTANT: If the bottom black manifold valve is turned to MAIN TANK, the Bag & Bottle Rinse uses diluted spray solution from the main tank to rinse containers of concentrated chemicals. Always rinse the chemical containers with clean water several times until they are clean before disposal. Turn the bottom black manifold valve to FLUSH TANK (optional) to use clean water to rinse the chemical containers.

13. Engage the hopper rinsing device by opening valve **(C)** (Fig. 18).
14. Close valve **(C)** (Fig. 18) when the hopper is rinsed.

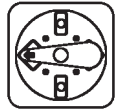

IMPORTANT: If the bottom black manifold valve is turned to MAIN TANK, the hopper uses diluted spray solution from the main tank to rinse the hopper of concentrated chemicals. Always rinse the hopper with clean water when finished spraying. Turn the bottom black manifold valve to FLUSH TANK (optional) to use clean water to rinse the chemical containers.

15. Close valve **(A)** (Fig. 18) and the chemical hopper lid. Turn the bottom black manifold valve back to MAIN TANK (if flush tank was used). Finish filling main tank with clean water to desired amount. When the spray liquid is well mixed, it may be sprayed on the crop. Leave the agitation valve at maximum agitation so the spray liquid is continuously agitated while spraying.





Operating with Powder-based chemicals

1. Make sure the ESC operating unit main on/off switch is in the "Off" position (See Section 4.8).
2. Fill the flush tank (optional) with clean water and fill the main tank at least 1/2 with clean water (unless something else is stated on the chemical container label). (See Sections 4.2, 4.3)
3. Turn the top green pressure manifold handle to the Chem Fill symbol. 
4. Turn the bottom black suction manifold handle to the Main Tank symbol. 
5. Any other manifold valves should be in the "Off" position.
6. Turn the agitation valve **(A)** (Fig. 17) counter clockwise all the way out for maximum agitation.
7. Engage the pump and set P.T.O. revolutions to 540 r.p.m. or 1000 r.p.m. (depending on pump model).
8. Open the bottom valve **(A)** (Fig. 19) on the HARDI® CHEMICAL FILLER and open the lid.
9. Engage the hopper rinsing device by opening valve **(C)** (Fig. 19).
10. Measure the correct quantity of chemical and sprinkle it into the hopper as fast as the rinsing device can flush it down.

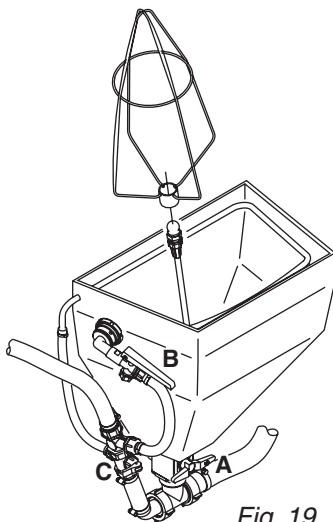

Fig. 19

11. If the chemical container is empty, it can be rinsed by using the Bag & Bottle Rinse (optional). Fit the bag bracket and place the powder bag over the multi-hole nozzle and press the lever **(B)** (Fig. 19).

WARNING: Do not press lever **(B)** (Fig. 19) unless the multi-hole nozzle is covered by a container to avoid spray liquid hitting the operator.

IMPORTANT: *If the bottom black manifold valve is turned to MAIN TANK, the Bag & Bottle Rinse uses diluted spray solution from the main tank to rinse containers of concentrated chemicals. Always rinse the chemical containers with clean water several times until they are clean before disposal. Turn the bottom black manifold valve to FLUSH TANK (optional) to use clean water to rinse the chemical containers.*

12. Close valve **(C)** (Fig. 19) when the hopper is rinsed.

IMPORTANT: *If the bottom black manifold valve is turned to MAIN TANK, the hopper uses diluted spray solution from the main tank to rinse the hopper of concentrated chemicals. Always rinse the hopper with clean water when finished spraying. Turn the bottom black manifold valve to FLUSH TANK (optional) to use clean water to rinse the chemical containers.*

13. Close valve **(A)** (Fig. 19) and the chemical hopper lid. Turn the bottom black manifold valve back to MAIN TANK (if flush tank was used). Finish filling main tank with clean water to desired amount. When the spray liquid is well mixed, it may be sprayed on the crop. Leave the agitation valve at maximum agitation so the spray liquid is continuously agitated while spraying.



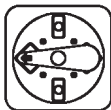

4.12 Use of Flush Tank and Rinse Nozzles (optional)

The incorporated flush tank can be used for two different purposes

A. In-field diluting of remaining spray liquid residue in the spraying circuit for spraying the liquid in the field, before cleaning the sprayer.

1. Empty the sprayer as much as possible. Turn the agitation valve (**A**) (Fig. 17) clockwise all the way in to close agitation valve and spray until air comes out of all nozzles.

Note: Do not run pump dry for longer than 3 seconds. Otherwise severe damage to the pump will occur.

2. Remove the tank filter basket.

3. Turn the optional green pressure manifold handle to the Tank Rinse symbol.



4. Turn the bottom black suction manifold handle to the Flush Tank symbol.



5. Make sure any other manifold valves are in the "Off" position.
6. Engage and set pump at approximately 300 r.p.m.
7. When rinsing water corresponding to approximately 10 times the spray liquid residue is used, turn the bottom black suction manifold handle to the Main Tank symbol and operate all valves so all hoses and components are rinsed.
8. Spray the liquid in the field you have just sprayed.
9. Repeat steps 3-8 until the flush tank is empty.



WARNING: The rinse nozzles cannot always guarantee a 100% cleaning of the tank. Always clean manually with a brush afterwards, especially if crops sensitive to the chemical just sprayed are going to be sprayed afterwards.

B. Rinsing the pump, operating unit, spray lines, etc. In case of interruption in spraying before main tank is empty (e.g. due to rain, etc.).

1. Turn the agitation valve **(A)** (Fig. 17) clockwise all the way in to close agitation valve.
2. Make sure the ESC operating unit main on/off switch is in the "On" position and that all individual on/off boom section switches are in the "On" position (See section 4.8).

3. Turn the top green pressure manifold handle to the ESC control symbol.



4. Turn the bottom black suction manifold handle to the Flush Tank symbol.



5. Make sure any other manifold valves are in the "Off" position.
6. Engage the pump and spray water from the flush tank in the field until all nozzle tubes/nozzles are flushed with clean water.
7. Disengage pump. Turn all manifold valves to the "Off" position.



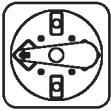

4.13 Operation Of The Tank Drain Valve

WARNING: BEFORE USING THE TOP DRAIN, VERIFY THAT DISPOSAL OF WASTE IS DONE ACCORDING TO CHEMICAL LABEL INSTRUCTIONS AND LOCAL REGULATIONS.

Pull the string at left hand side of the tank to open the drain valve. The valve is spring loaded to close it, but can be kept open by pulling the string out-and upwards in the V-shaped slot (Fig. 20).

To release and close the drain valve again, pull the string downwards and the valve will close automatically (Fig. 20).

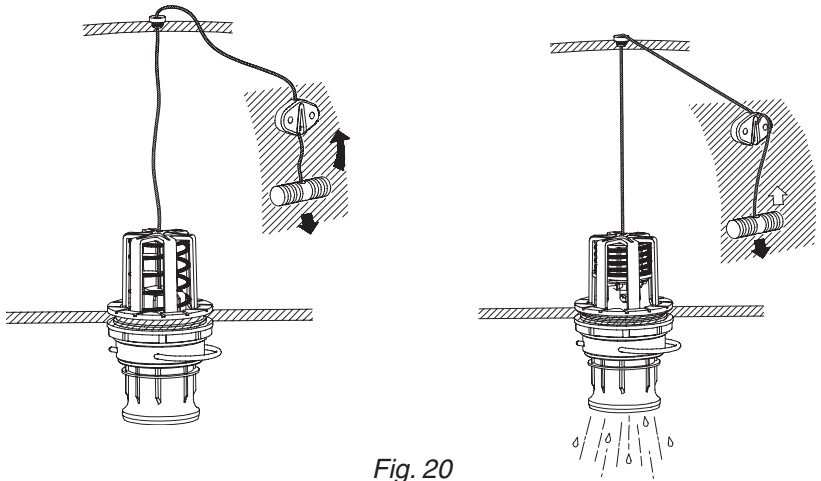

If draining residues, e.g. liquid fertilizer into a reservoir, a snap-coupler with hose can rapidly be connected to the drain valve and the liquid safely drained.

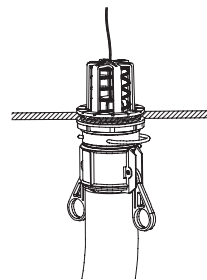

4.14 Nozzle Selection

Correct selection of nozzle and calibration of the sprayer are critical to achieve accurate and cost effective use of farm crop protection products.

Your HARDI® sprayer has been supplied with 110° flat spray Red ISO Color Tips™ that will apply approximately 20 U.S. GPA at 30 PSI and 5 MPH.

The 110° flat spray nozzle was chosen rather than the 80 degree nozzle for two reasons: 1- It may be used at a lower minimum height which reduces the risk of wind drift; 2- it's greater overlap permits better uniformity of spray distribution, particularly if boom height varies on rough ground. Normal boom height setting with 110° nozzles is 18" to 20" above the crop or weeds, whichever is taller.

Should you wish a different application rate or different type of nozzle, HARDI® manufactures a nozzle for virtually every need.



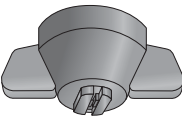
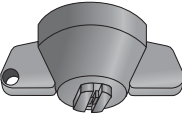

IMPORTANT: Always consult your chemical supplier for recommended chemical rate and water application rate. Always wear protective gloves when handling nozzles.

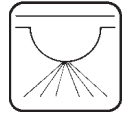
The following tables show what types of spray nozzles are suitable for different applications. It is important to use the correct nozzle.

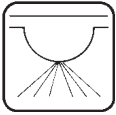
	<p>HARDI® ISO COLOR TIPS™ 110 degree flat fan, one piece cap and nozzle; color coded for flow rate selection. For herbicides, insecticides, and fertilizer applications. 50, 80, and 100 mesh screens are normally used.</p>	<p>F110</p>
	<p>HARDI® ISO LowDrift COLOR TIPS™ 110 degree flat fan, one piece cap and nozzle, 1553 solid stream nozzle; color coded for flow rate selection. In-Line Filters will normally be used.</p>	<p>LD110</p>

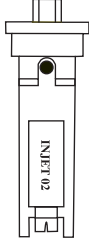

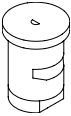

	<p>HARDI® INJET™ NOZZLES; air inclusion nozzles with removable restrictor. Color coded for flow rate selection. In-Line Filters will normally be used.</p>	
	<p>FLAT SPRAY NOZZLES in 65 degree, 80 degree, and 110 degree spray angles. For herbicides, insecticides, and fertilizer applications. 50, 80, and 100 mesh screens are normally used.</p>	<p>4665-65 degree 2080-80 degree 4110-110 degree</p> <p>Part # 330013-O-ring</p>
	<p>FLOOD NOZZLES set at 40° spacing. Designed for high volume application.</p>	<p>4598</p>
	<p>HOLLOW CONE NOZZLES for high pressure and high volume insecticide application in row crops. 1553 nozzles are ALWAYS used with swirl plates shown below EXCEPT when used as solid stream nozzles. 50, 80, or 100 mesh screens are normally used with these nozzles</p>	<p>1553 Must add swirl to produce hollow cone pattern</p>
	<p>SWIRL PLATE used in conjunction with cone nozzle to create desired spray pattern. These swirls work with 1553 series cone nozzles. Grey, blue, or black swirls are used to create hollow cone effect. White swirls are used to create full cone effect.</p>	<p>Grey Blue Black White</p>

	<p>HOLLOW CONE CERAMIC NOZZLES for high pressure and high volume fungicide and insecticide application.</p>	<p>1299</p>
	<p>LARGE DROPLET HOLLOW CONE NOZZLE for use where drift must be kept to a minimum. These nozzles must always be fitted with 1553 nozzles and grey swirl plates. 50, 80 or 100 mesh screens are normally used with these nozzles.</p>	<p>371077</p>
	<p>LARGE DROPLET FLAT SPRAY TIP IN 150 DEGREE SPRAY ANGLE. Always used in conjunction with 1553-14-16-18 or 20 cone nozzle. 50, 80 or 100 mesh screens are normally used with these nozzles.</p>	<p>371551</p>
	<p>SOLID STREAM NOZZLE for high volume liquid fertilizer application. In this application, the 1553 nozzle is always used with 330013 o-ring and 50, 80 or 100 mesh screens.</p>	<p>1553 less swirl</p>
	<p>HARDI® QUINTASTREAM 5 HOLE LIQUID FERTILIZER NOZZLE Five streams of liquid are distributed at different angles and flows. Highest flow is from the middle stream and lowest in the outer; overlapping streams. This allows for boom movements that do not influence distribution. Boom heights of 20" can be used as safely as 30".</p>	<p>372011 thru 372019</p>

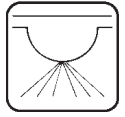



4.15 Calibration

WARNING: ALWAYS CALIBRATE YOUR SPRAYER WITH CLEAN WATER ONLY! IN ADDITION, WEAR PROTECTIVE CLOTHING WHEN CALIBRATING YOUR SPRAYER!



Why must you calibrate a sprayer?

A nozzle selection chart will tell you what application rate you should expect. Variations due to nozzle wear, errors in pressure adjustment, and tractor speedometer can result in a possible error in application rate.

How do you calibrate a sprayer?

Calibration kits are available from HARDI®, #818493 for US gallons & #818492 for metric calibration.

Following are some tips to remember when using the calibration kit method:

- When determining the length of time required to drive the recommended distance, drive in actual field conditions with a half-full tank.
- Repeat the test several times, each time avoiding the tracks from the previous test. Take the average of the times recorded.
- Calibration of the sprayer should be completed at the beginning of the season and repeated after every 2 to 3 full days of spraying, and every time you change volume rate or use new nozzles.
- Before you calibrate, check the flow of each nozzle. If it puts out more than 10% of its original volume, replace it.

Select your calibration method: Ounce method or Formula method. Then follow the steps described in the corresponding section(s):

Ounce Method



1. Determine how long it takes to cover the test strip. Use the following chart to determine the length of your test strip. Row width for broadcast application is equal to your nozzle spacing. For your drop nozzle or band application, use row spacing.

<u>Row width or nozzle spacing (in.)</u>	<u>Distance (ft.)</u>
40	102
38	107
36	113
34	120
32	127
30	136
28	146
26	157
24	170
22	185
20	204
18	227
16	255
14	291

2. Measure the amount of time it takes you to travel the test strip when throttle is set at spraying speed.
3. In a container (with oz. measurements), catch the spray from one nozzle for that amount of time. For drop or band nozzles, catch the spray from all nozzles for the row.
4. Read the ounces in the container. That is the actual U.S. GPA applied. (ounces = GPA)



Formula Method

1. Check your spraying speed. Measure a test strip of at least 200 feet (300 feet is ideal). Travel the distance at the speed you plan on spraying and record the time it takes to travel the distance. Read from the chart or use the formula to find your exact travel speed.

Travel Time (in seconds)

	Speed in MPH	200 ft.	300 ft.
	3.0	45	68
	3.5	39	58
	4.0	34	51
	4.5	30	45
	5.0	27	41
	6.0	23	34
	7.0	19	29
	7.5	18	27
	8.0	17	26
	9.0	15	23

Formula:

$$\frac{\text{distance (ft.)} \times 0.68}{\text{seconds}} = \text{MPH}$$

Formula:

$$\text{GPM} = \frac{10 \times 7 \times 20}{5940} = .24 \text{ GPM}$$

- Note:** W=
- Nozzle spacing (in inches) for broadcast application.
 - Row spacing (in inches) divided by number of nozzles per row for drop nozzle application.
 - Sprayed band width or swath width (in inches) for band application divided by number of nozzles per band.
 - Note that on the nozzle wheel, W = 20 inches.

3. Set correct pressure. Read the required pressure from the nozzle table in the nozzle catalogue or nozzle wheel. With clean water in the tank and line, turn on the sprayer and set the target pressure. Collect the spray from one nozzle for one minute in a container. Adjust pressure until you collect the precise GPM called for.

Calibration For Carriers Other Than Water

Use the following water rate conversion chart to determine the right conversion factor. When you've determined the new converted GPM or GPA, you can follow the steps on either the pressure or ounce method of calibration.



<u>Weight of solution</u>	<u>Specific Gravity</u>	<u>Conversion Factors</u>
7.00 lbs/gal	.84	.92
8.00 lbs/gal	.96	.98
8.34 lbs/gal-water	1.00	1.00
9.00 lbs/gal	1.08	1.04
10.00 lbs/gal	1.20	1.10
10.65 lbs/gal-28% N	1.28	1.13
11.00 lbs/gal	1.32	1.15
12.00 lbs/gal	1.44	1.20
14.00 lbs/gal	1.68	1.30

Example: 20 GPA of 28% N
Then GPA (solution) x conversion factor = GPA (water)
20 GPA (28% N) x 1.13 = 22.6 GPA (water)
Calibrate for 22.6 GPA of water

For conversion to Imperial gallons per acre, multiply U.S. GPA by .833

For conversion to liters per hectare, multiply U.S. GPA by 9.34

For conversion to liters per acre, multiply U.S. GPA by 3.78

Formula for tractor speed: $\frac{\text{Distance (in feet)}}{\text{Second}} \times .682 = \text{MPH}$



5.0 MAINTENANCE

IMPORTANT: *Always clean the boom at the end of your workday or before servicing is done to avoid unnecessary contact with chemicals.*



In order to derive full benefit from the sprayer for many years, the following service and maintenance program should be followed.

5.1 Cleaning The Sprayer

Guidelines

Read the whole chemical label. Take note of any particular instructions regarding recommended protective clothing, deactivating agents, etc. Read the detergent and deactivating agent labels. If cleaning procedures are given, follow them closely.

Be familiar with local legislation regarding disposal of pesticides washings, mandatory decontamination methods, etc. Contact the appropriate department, e.g. Dept. of Agriculture.

Pesticide washings can usually be sprayed out on a soakaway. This is an area of ground that is not used for cropping. You must avoid seepage or runoff of residue into streams, water courses, ditches, wells, springs, etc. The washings from the cleaning area must not enter sewers. Drainage must lead to an approved soakaway.

Cleaning starts with the calibration, as a well calibrated sprayer will ensure the minimal amount of remaining spray liquid.

It is good practice to clean the sprayer immediately after use, thereby rendering the sprayer safe and ready for the next pesticide application. This also prolongs the life of the components.

It is sometimes necessary to leave spray liquid in the tank for short periods, e.g. overnight, or until the weather becomes suitable for spraying again. Unauthorized persons and animals must not have access to the sprayer under these circumstances.

If the product applied is corrosive, it is recommended to coat all metal parts of the sprayer before and after use with a suitable rust inhibitor.

Remember: Clean sprayers are safe sprayers.

Clean sprayers are ready for action.

Clean sprayers can not be damaged by pesticides and their solvents.

Cleaning the tank

1. Dilute remaining spray liquid in the tank with at least 10 parts of water and spray the liquid out in the field you have just sprayed.
Note: It is advisable to increase the forward speed (double if possible) and reduce the pressure. For ISO F110 nozzles, pressure may be reduced to 22psi (1.5 bar).
2. Select and use the appropriate protective clothing. Select detergent suitable for cleaning and suitable deactivating agents if necessary.
3. Rinse and clean sprayer and tractor externally. Use detergent if necessary.
4. Remove and clean tank filters and suction filters. Be careful not to damage the mesh. Replace suction filter lid. Replace filters when the sprayer is completely clean.
5. With the pump running, rinse the inside of the tank. Remember the tank roof. Rinse and operate all components and any equipment that has been in contact with the chemical.
6. After spraying the liquid out again in the field, stop the pump and fill at least 1/5 of the tank with clean water. Note that some chemicals require the tank to be completely filled. Add appropriate detergent and/or deactivating agent, eg. Washing soda or Triple ammonia.
Note: If a cleaning procedure is given on the chemical label, follow it closely.
7. Start the pump and operate all controls enabling the liquid to come in contact with all the components. Leave the distribution valves until last. Some detergents and deactivating agents work best if left in the tank for a short period. Check the label.
8. Drain the tank and let pump run dry, only for a few seconds. Rinse inside of tank, again letting the pump run dry again only for a few seconds.
Note: Do not run pump dry for longer than 3 seconds. Otherwise severe damage to the pump will occur.
9. Stop the pump. If the chemicals used have a tendency to block nozzles and filters, remove and clean them now.
10. Replace all the filters and nozzles and store the sprayer. If, from previous experiences, it is noted that the solvents in the chemicals are particularly aggressive, store the sprayer with the tank lid open.
Note: If the sprayer is cleaned with a high pressure cleaner we recommend lubrication of the entire machine.

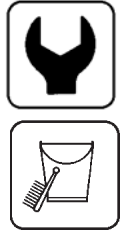







5.2 Filters

IMPORTANT: *Wear protective clothing when servicing & handling components that have been in contact with spray liquid.*

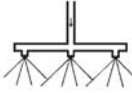

Clean filters ensure :

- Sprayer components such as valves, diaphragms and operating unit are not hindered or damaged during operation.
- Nozzle blockages do not occur while spraying.
- Long life of pump. A blocked suction filter will result in pump cavitation.

ISO Nozzle Size 	Suction Filter (optional) 	Inline Filters (optional) 	Nozzle Screen 	Pressure Filter 
Pink (075) Orange (01) Green (015) Yellow (02)	50	100	100	100
Lilac (025) Blue (03)	50	80	80	80
Red (04) & Larger	30*	50*	50*	50*

* Standard mesh

5.3 Recommended Tire Pressure

The tires should not run under-inflated. This only promotes instability and rapid wear.

NAVIGATOR 550M

<u>Tire size:</u>	<u>Maximum pressure:</u>
11L x 15"	36 psi (2.5 bar)
11.2 x 38"	24 psi (1.6 bar)
12.4 x 24"	24 psi (1.6 bar)

NAVIGATOR 800M/1000M

<u>Tire size:</u>	<u>Maximum pressure:</u>
12.5L x 15"	36 psi (2.5 bar) - (TA no longer available)
13.6 x 38"	29 psi (2.0 bar)
12.4 x 42" 10 ply	36 psi (2.5 bar)

The pressure is specified for a fully loaded trailer. When traveling on hard road surfaces with a maximum load, do not exceed 15 mph. Remember it is easier to let off a little pressure for a specific use than to re-inflate a tire in mid-field.

5.4 Wheel Nuts And Bearings Adjustment

WARNING: BLOCK WHEELS ON TRAILER TO PREVENT ROLLING.

Check wheel bolt tension after the first 8 working hours, hereafter every 50 hours. Torque wheel nuts to 85 ft. lbs. maximum.

Check bearing for slack after the first 8 hours of operation and again after 50 hours of operation. Thereafter every 100 hours. (Fig. 21)

If necessary, adjust as follows:

1. Jack sprayer up. It is best to remove the wheel. (Make sure to adequately support the sprayer and completely drain tank.)
2. Remove hub cap and cotter pin.
3. Axle nut is tightened until slight rotation resistance of hub is noted.
4. Now loosen axle nut until first split pin hole is visible.
5. Insert cotter pin, fold and replace hub cap.

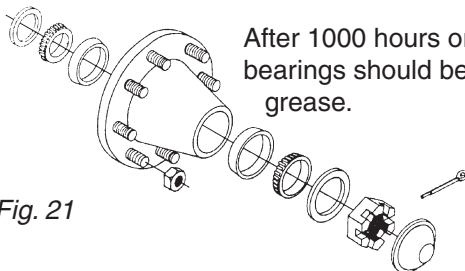

Fig. 21

After 1000 hours or once a year, the axle bearings should be repacked with new grease.





5.5 Tandem Axles

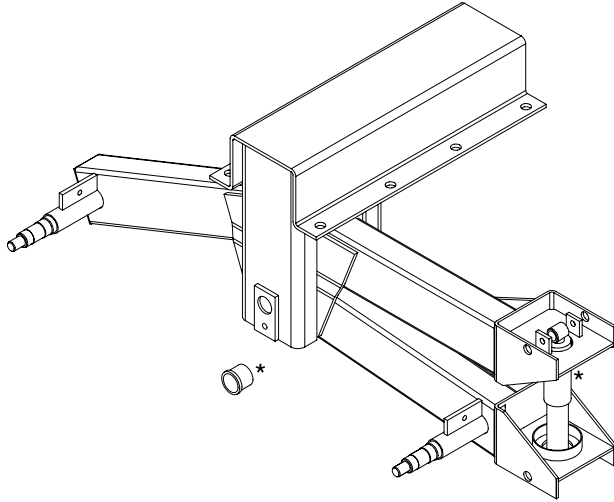

Fig. 22

*Check all shocks and all bearings every 1000 hours and replace if needed.

Note: Tandem axles are only available on Navigator 550M.

5.6 Nozzle Tubes And Fittings

Poor seals are usually caused by;

- Missing O-rings or gaskets
- Damaged or incorrectly seated O-rings
- Dry or deformed O-rings or gaskets
- Foreign materials

Therefore, in case of leaks; **DO NOT** overtighten (Fig. 23). Disassemble, check condition and position of O-ring or gasket, clean, lubricate and reassemble.

For **radial** type seals (O-ring)(Fig.23) hand tighten only, do not use pliers.

The O-rings need to be lubricated **ALL THE WAY AROUND** before fitting on to the nozzle tube.

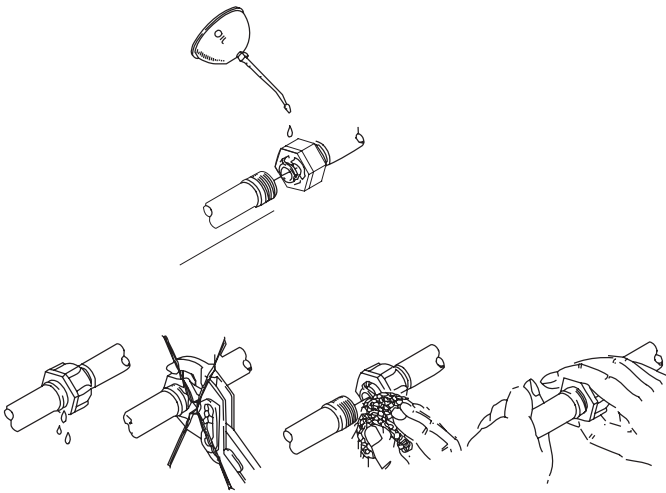

Fig. 23

HARDI® recommends using a vegetable based oil to prolong the life of the O-ring.





5.7 Checking The Valve Cone In Distribution Valves

Periodically check the distribution valves for proper sealing. This is done while operating the sprayer with clean water.

1. Flush the sprayer with clean water and open all of the distribution valves.
2. Cautiously remove clip **(A)** (Fig. 24) and remove hose **(B)** (Fig. 24) for the constant pressure device. When the housing is drained, bring the sprayer up to operating pressure. If fluid continues to leak from the housing, the valve cone **(E)** (Fig. 24) must be changed.
3. Shut the sprayer off and remove clip **(C)** (Fig. 24). Pull the electrical motor off the valve housing.
4. Remove screw **(D)** (Fig. 24) and replace the valve cone **(E)** (Fig. 24). Reassemble in reverse order. Secure screw **(D)** (Fig. 24) with Loctite.

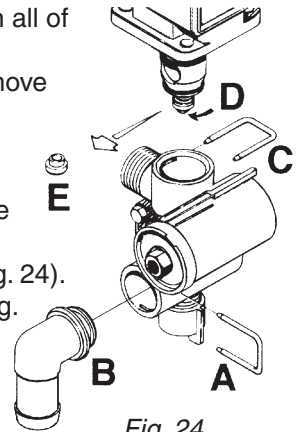

Fig. 24

5.8 Hydraulic Driven Pump Repair Parts

- 204, 210, 310 (VALOX STD.) - 10527403
- 204, 210, 310 (CAST IRON) - 10527503
- 206-150 (CAST IRON) - 28022803
- 206-150 (VALOX STD.) - 28022703
- 304 (CAST IRON) - 28027203
- 304 (VALOX STD.) - 28027303

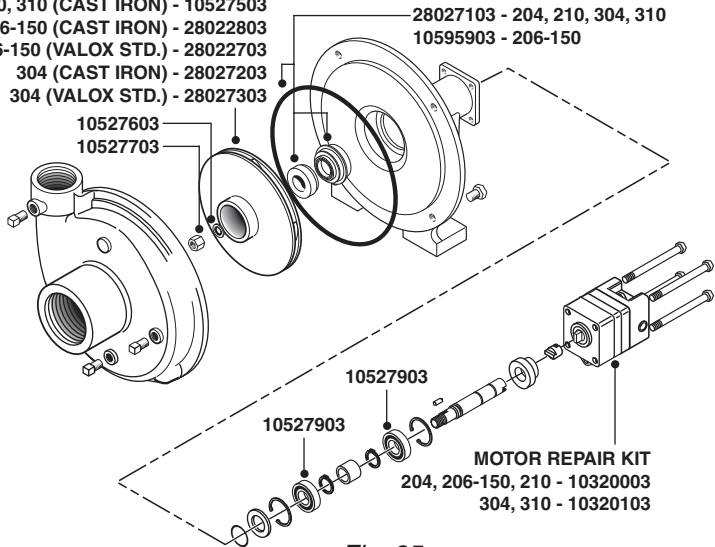

Fig. 25

Note: Any parts needed that are not shown, are available at your local ACE pump supplier.

5.9 P.T.O. Belt Driven Pump Repair Parts

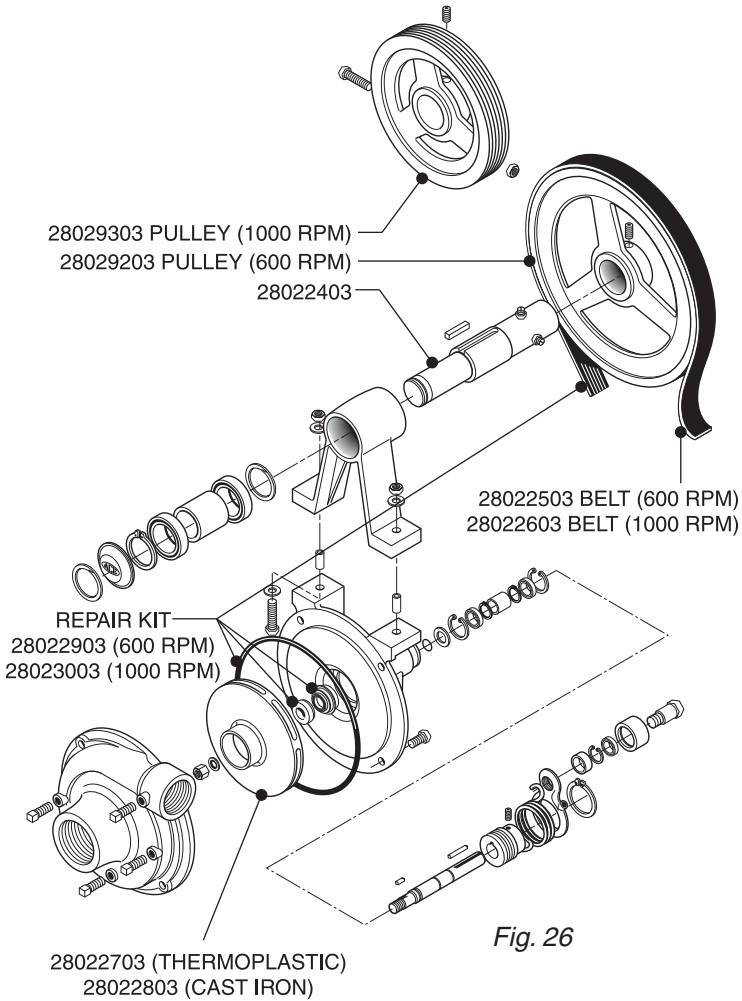

Fig. 26

Note: Any parts needed that are not shown, are available at your local ACE pump supplier.



5.10 Emergency Operation Of ESC Controls

In case of power failure, it is possible to operate all functions of the operating unit manually.

First disconnect the multiplug from the control box. Now manually turn the emergency control knobs.

The problem may be due to a blown fuse. The fuses are placed in the control box and are marked according to functions.

Fuse type:

0.5 Amp (HARDI® #261125)

1.25 Amp (HARDI® #261589)

6.3 Amp (HARDI® #261090)

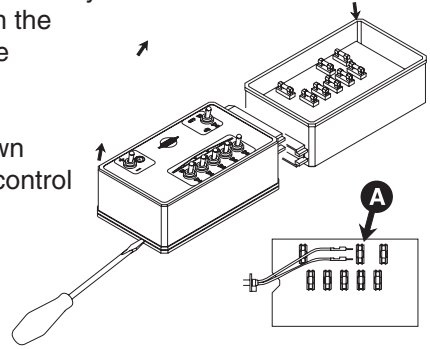

Fig. 27

5.11 Level Indicator

The level indicator should be checked regularly. When the tank is empty, the floater should rest on the stop pin on the rod and the O-ring at the indicator should be positioned at the top position line (A) (Fig. 28).

If any deviation is found, pull out the plug (B) (Fig. 28), loosen the screws (C) (Fig. 28) and adjust the length of the cord.

Note: The level indicator is not meant to be an accurate indication of the specific volume of your tank. Variations due to the adjustment of the indicator, positioning of the sprayer and the production of the tank itself, are all factors leading to some inaccuracy. For precise measurement rely only on weight of the liquid or precise flowmeters when filling the tank.

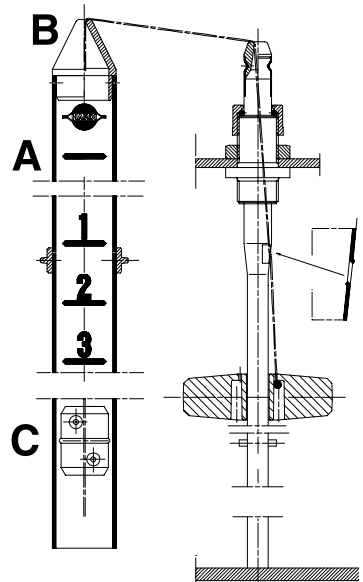

Fig. 28





5.12 Lubrication

Recommended lubrication is shown in following tables.

Use ball bearing grease (lithium grease No. 2)



Note: If the sprayer is cleaned with a high pressure cleaner or fertilizer has been used, we recommend lubrication of all sections. See Eagle™ manual for boom greasing.

POS.	Position on sprayer		Grease		Page to find more information
	Oil		Operation hours		Winter protection or off-season storage

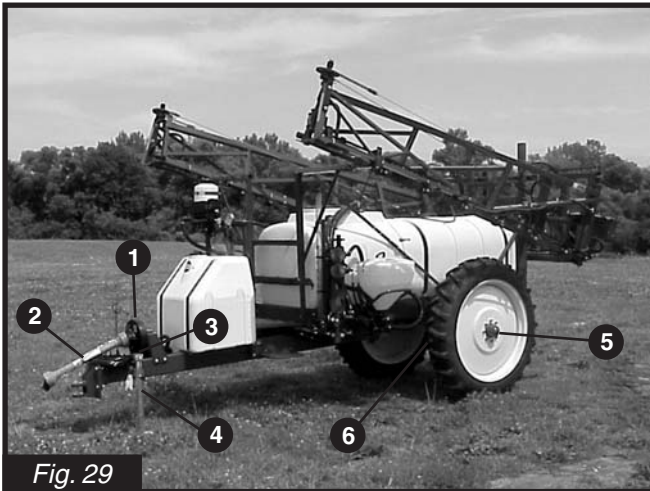



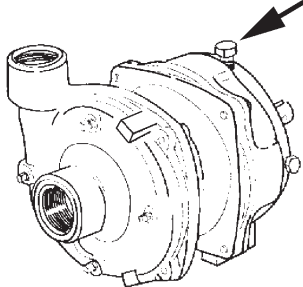
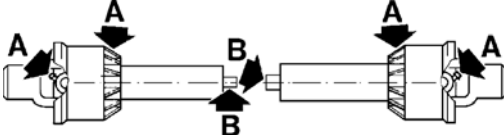
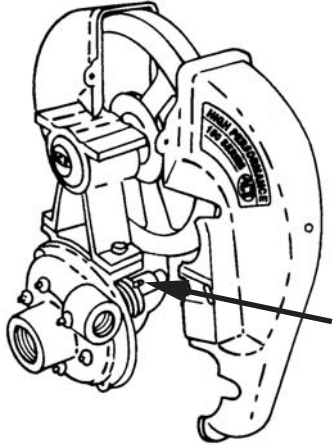





Fig. 29

Navigator 550M Centrifugal (Shown)

1. Pump
2. P.T.O. (P.T.O. driven pumps only)
3. Idler arm (Belt driven pumps only)
4. Hitch Jack
5. Wheel Bearings
6. Tandem Axle (optional/not shown)

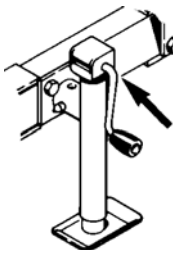
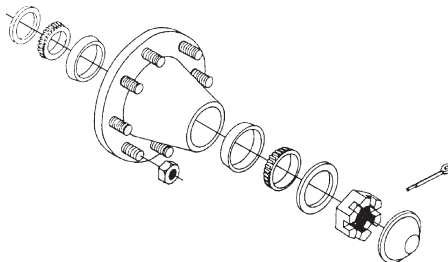
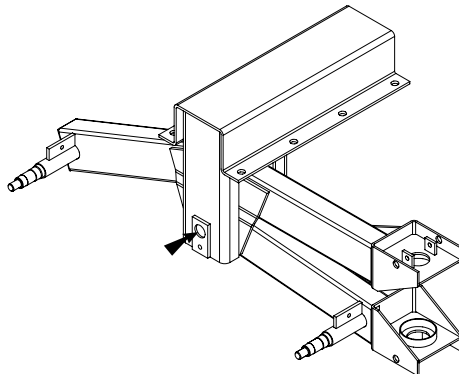

POS.					
1	X		50	 <p data-bbox="599 502 823 526">9016/18 pumps only</p>	
2	A B	X X	10 50		16 16
3		X	40		

POS.					
4		X	50		
5		X	1000		45
6		X	50		46





6.0 OFF-SEASON STORAGE

When the spraying season is over, you should devote some extra time to the Sprayer. If chemical residues are left over in the sprayer for long periods, it can reduce the life of the individual components. To preserve the sprayer and protect the components, carry out the following off-season storage program:

1. Clean the sprayer completely - inside and outside - as described under "Cleaning The Sprayer" (Section 5.1). Make sure that all valves, hoses and auxiliary equipment have been cleaned with detergent and flushed with clean water afterwards, so no chemical residues are left in the sprayer.
2. Replace any damaged seals and repair any leaks.
3. Empty the sprayer completely and let the pump run dry, only for a few seconds. Operate all valves and handles to drain as much water out of the spraying circuit as possible. Let the pump run until air is coming out of all nozzles. Remember to drain the flush tank also.

Note: Do not run pump dry for longer than 3 seconds. Otherwise severe damage to the pump will occur.

4. Pour appr. 13 gal. (50 liters) antifreeze mixture consisting of 1/3 automotive antifreeze and 2/3 water into the tank.
5. Engage the pump and operate all valves and functions on the MANIFOLD system, ESC unit, CHEM FILLER etc. allowing the antifreeze mixture to be distributed around the entire circuit. Open the ESC main on/off switch and distribution valves so the antifreeze is sprayed through the nozzles as well. The antifreeze will also prevent O-rings, seals, diaphragms etc. from drying out.
6. When the sprayer is dry, remove rust from any scratches or damages in the paint and touch up the paint.
7. Lubricate all lubricating points according to the lubricating scheme regardless of intervals stated.
8. Remove the glycerine-filled pressure gauges and store them in a vertical position in frost free conditions.
9. Apply a thin layer of anticorrosive oil (e.g. SHELL ENSIS FLUID, CASTROL RUSTILLO or similar) on all metal parts. Avoid oil on rubber parts, hoses and tires.
10. Fold the boom in transport position and relieve pressure from all hydraulic functions.

Off-Season Storage (continued)

11. All electric plugs and sockets are to be stored in a dry plastic bag to protect them against moisture, dirt, and corrosion.
12. Remove all the control boxes (including any rate controller/monitor control box and display) from the tractor and store them in a dry and clean condition.
13. Wipe hydraulic snap-couplers clean and fit the dust caps.
14. Apply grease on all hydraulic ram piston rods which are not fully retracted in the barrel to protect against corrosion.
15. Jack up the axle and place wooden blocks under the wheels, to prevent moisture damage and deformation of the tires. Tire black can be applied to the tire side walls to preserve the rubber.
16. To protect against dust, the sprayer can be covered by a tarpaulin. Ensure ventilation to prevent condensation



6.1 Preparation After Off-Season Storage

After a storage period the sprayer should be prepared for the next season the following way:

1. Remove the cover. (If fitted)
2. Remove the blocks from under the wheels and adjust the tire pressure.
3. Wipe off the grease from hydraulic ram piston rods.
4. Fit the pressure gauges again. Seal with Teflon tape.
5. Connect the sprayer to the tractor, including hydraulics and electrics.
6. Check all hydraulic and electric functions.
7. Empty the tank of remaining antifreeze.
8. Rinse the entire liquid circuit on the sprayer with clean water.
9. Fill with clean water and check all functions.



7.0 ACCESSORIES

7.1 Clean Water Dispenser



Fig. 30

Clean Water Dispenser & Mounting Bracket (Eagle™ boom shown)

A handy source of fresh water on the sprayer to clean up plugged nozzles and for rinsing gloves and hands after performing service or maintenance.

7.2 Chemical Filler (optional)



Fig. 31

Chemical Filler Attachment Installed

Will inject all types of chemical formulations, liquid, powder or granules, into the bottom of the tank near the agitation flow. A cleaning ring ensures that chemical residue is removed from the filler tank.

7.3 Chemical Filler Bag & Bottle Rinse Kit (optional)



Fig. 32

Chemical-Filler Bag & Bottle Rinse Kit

A container rinse kit for liquid containers or plastic bags is also available for installation into the chemical filler hopper.

7.4 Nurse Tank Quick Fill (optional)

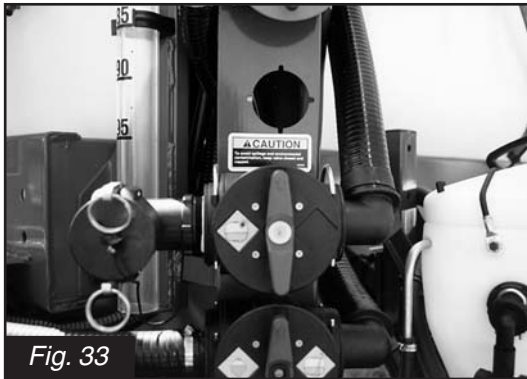

Fig. 33

Nurse Tank Quick Fill

A quick attach hook-up for filling the sprayer tank from a nurse tank. Liquid is fed into the bottom of the tank through a one-way valve providing a better mix of water and chemical. The quick fill is equipped with a handy 1/4 turn shut-off valve.



7.5 Foam Marker System (optional)



*Fig. 34
Foam Marker Tank & Compressor*



Fig. 35

Foam Marker Drop Assembly

The Foam Marker helps prevent skipping or over lapping during spray application of spray solution, both which can be costly. HARDI® Foam Marker features a trailer mounted compressor, poly tank, extruded foamer hoses and in-cab electrical controls providing right or left drop selection and the rate/quality of foam droplets. Refer to the Foam Marker Operator's Manual for complete operation instructions.

7.6 4" Boom Pressure Gauge (optional)



Fig.36

4" Boom Pressure Gauge

A large and easy to read 4" boom pressure gauge to replace the standard 2-1/2" gauge. This gauge is to be mounted near the tractor cab allowing the operator to monitor the boom pressure for more accurate control of the application rate.

7.7 Flush System (optional)



Fig.37

Flush Tank (90 gal. shown)

Flush system provides a means to be able to flush the pump, controls, boom feed lines and complete boom and nozzles with clean water from a 90 gal. tank.



7.8 Tank Rinse System (optional)

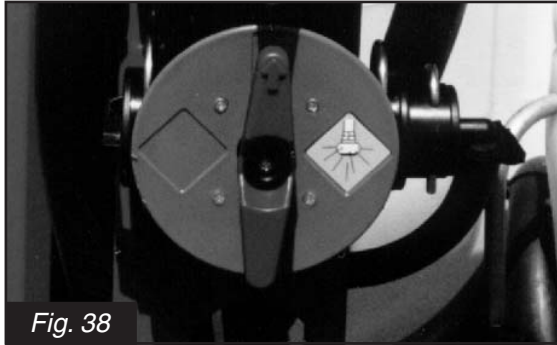

Manifold Rinse Valve



Rinse Nozzle on Top of Tank

The Rinse system can be added to the flush system which provides a means to rinse the main tank using pressurized water to spray the inside of the tank through specially designed spinning nozzles.

7.9 Spraygun And Hose Wrap (optional)

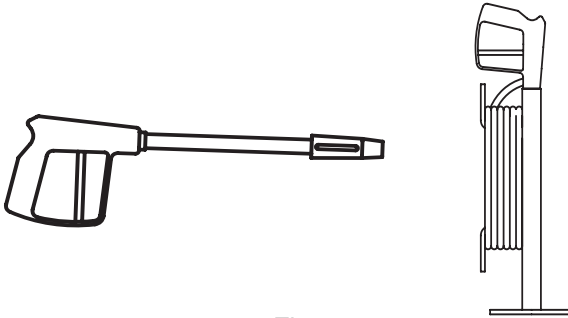

*Fig. 40
Spraygun*

A spraygun with adjustable spray pattern and 25 ft. of hose for spraying fence row or spot spraying a small area can be installed onto your sprayer. A handy hose wrap and spraygun holder can be conveniently located on the sprayer to transport the spraygun.

7.10 HARDI® Monitor 1500 (optional)



The HARDI® Monitor 1500 monitors the application rate. When used with the electric control unit switch box, correct area covered and up to 8 spray boom section control is possible. Components can be added for your individual requirements to control your operating unit, and optional equipment.



7.11 HARDI® Controller 2500 (optional)



Fig. 42

The HARDI® Controller 2500 permits automatic control of the application rate. This allows you to concentrate on driving as the rate is automatically maintained by the HC 2500. Press the "up" or "down" arrow key to change the application rate. Easy, quick and simple. Up to 8 spray boom section control is possible.

7.12 Mustang 3500 Controller (optional)



The Mustang 3500 Controller offers fully integrated boom controls (3-7 sections), integrated foam marker controls, 3 possible preprogrammed application rate settings, 9 different field counters, DGPS compatible, prepared for communication with Precision Farming Terminals and pocket PC's (iPAQ - models: 3650, 3670), variable rate application, rain & dust proof and 3 year warranty.

8.0 TROUBLESHOOTING

8.1 General Spray Systems

Problem	Cause
1. No liquid getting to the pump.	A. Suction side plugged. B. Suction filter plugging (If fitted).
2. Lack of pressure	A. Suction side plugged. B. Suction filter plugging (If fitted). C. Hydraulic motor shaft coupling loose or fork pin missing. D. Flow limiting valve closed because of too much hydraulic flow to the pump motor. E. P.T.O. speed not fast enough (P.T.O. driven pumps only). F. Bad seat on spool valve for boom section control. G. Flush valve not in correct position. (Units equipped with Flush & Rinse™ system only). H. Bad suction valve or suction side air leak. I. P.T.O. not engaged (P.T.O. driven pumps only). J. Belt broke or missing (Belt Driven pumps only).
3. Pressure jumping	A. Output from by-pass lines causing a disturbance around suction hose. B. Small tear or pin hole in suction hose. C. Bad O-ring on suction filter (if fitted). D. P.T.O. shaft slipping on pump crank shaft (P.T.O. driven pumps only). E. Suction side air leak.





- | | |
|--|--|
| 4. Pressure dropping | A. Output from by-pass lines causing a disturbance around suction tube.
B. Suction filter plugging (If fitted).
C. P.T.O. shaft slipping on pump crank shaft (P.T.O. driven pumps only).
D. Bad seat on spool valve for boom section control.
E. Bad suction valve or suction side air leak. |
| 5. Liquid leaking from pump | A. Damaged pump seal. |
| 6. Electric control unit not functioning | A. Fuse blown.
B. ESC motor bad or micro-switch plate loose.
C. Bad seat on spool valve.
D. Bad switch or plug on control box.
E. Print board at back of control corroded or damaged. |
| 7. Less spray out of one boom section than others. | A. Bad seat on spool valve for boom section control. |
| 8. Poor agitation | A. Agitation valve not open.
B. Agitation nozzle plugged.
C. Agitation nozzle missing. |
| 9. Excessive vibrations in hoses | A. P.T.O. shaft slipping on pump crank shaft (P.T.O. driven pumps only).
B. Suction side air leak. |
| 10. Can't get tank empty. | A. Output from by-pass lines causing a disturbance around suction tube.
B. Crack or pin hole in suction tube.
C. Tank is not level (change angle of tongue). |

11. Boom nozzle leaking.

- A. Seat on boom section shut-off valve is worn or cracked.
- B. Bad seat on spool valve.
- C. Bad Non-Drip valve diaphragm.



8.2 Foam Marker

Problem

1. Compressor will not run.

Cause

- A. Short in electrical system or bad compressor.
- B. 12 volt supply not connected or bad connection.
- C. Weak power supply.
- D. Fuse blown.
- E. Defective switch in control box.
- F. Bad printboard (Pre 2002).

2. Compressor runs but will not make foam.

- A. Solenoid not working.
- B. Not enough foam concentrate.
- C. Solenoid valve plugged.
- D. Weak power supply.
- E. Bad printboard (Pre 2002).

3. Will not make enough foam.

- A. Line leak or line pinched.
- B. Solenoid valve plugged.
- C. Weak foam concentrate mixture.
- D. Water too hard (add water softener).

4. Foam drops will not last.

- A. Not enough foam concentrate.
- B. Frequency valve not opened enough (Pre 2002).
- C. Weak foam concentrate.
- D. Water too hard (Add water softener).



5. Keeps blowing fuses.

- A. Short in electrical system or bad compressor.
- B. Weak power supply.
- C. Bad relay on printboard (Pre 2002).
- D. Tank filter plugged.

8.3 Flush & Rinse™

1. System will not flush (pump, control, and boom)

- A. Flush valve not in correct position.
- B. P.T.O. not engaged.
- C. Flow limiting valve closed because of too much hydraulic flow to the pump motor.

2. System will flush but not rinse.

- A. Rinse valve not in correct position.

3. Rinse nozzle has poor output.

- A. Bad flush valve or suction side air leak.
- B. Rinse valve not in correct position.
- D. Pressure too low or high (rinse nozzle gauge).

8.4 Chemical Filler

1. Filler tank will not empty.

- A. Pressure selection valve not in correct position.
- B. Not enough flow from pump.
- C. Sprayer pump not running.

2. Filler tank empties too slow.

- A. Bottom tank discharge valve not open all the way.
- B. Not enough flow from pump.

3. Filler tank backfills when bottom tank discharge valve is open.

- A. Restrictor cone missing.
- B. Restrictor cone on wrong side of the valve.
- C. Not enough flow from pump.

9.0 WARRANTY POLICY AND CONDITIONS

HARDI® INC. , 1500 West 76th Street, Davenport, Iowa, USA; 8550 W. Roosevelt Avenue, Visalia, California, USA and 290 Sovereign Road, London, Ontario, Canada hereinafter called "HARDI®", offers the following limited warranty in accordance with the provisions below to each original retail purchaser of HARDI® new equipment of its own manufacturer, from an authorized HARDI® dealer, that such equipment is at the time of delivery to such purchaser, free from defects in material and workmanship and that such equipment will be warranted for a period of one year from the date of delivery to the end user providing the machine is used and serviced in accordance with the recommendations in the Operator's Manual and is operated under normal farm conditions.



1. This limited warranty is subject to the following exceptions:
 - a) Parts of the machine not manufactured by HARDI®. (i.e. engines, tires, tubes, electronic controls, and other components or trade accessories, etc.) are not covered by this warranty but are subject to the warranty of the original manufacturer. Any claim falling into this category will be taken up with the manufacturer concerned.
 - b) This warranty will be withdrawn if any equipment has been used for purposes other than for which it was intended or if it has been misused, neglected, or damaged by accident, let out on hire or furnished by a rental agency. Nor can claims be accepted if parts other than those manufactured by HARDI® have been incorporated in any of our equipment. Further, HARDI® shall not be responsible for damage in transit or handling by any common carrier and under no circumstances within or without the warranty period will HARDI® be liable for damages of loss of use, or damages resulting from delay or any consequential damage.
2. We cannot be held responsible for loss of livestock, loss of crops, loss because of delays in harvesting or any expense or loss incurred for labor, supplies, substitute machinery, rental for any other reason, or for injuries either to the owner or to a third party, nor can we be called upon to be responsible for labor charges, other than originally agreed, incurred in the removal or replacement of components.
3. The customer will be responsible for and bear the costs of:
 - a) Normal maintenance such as greasing, maintenance of oil levels, minor adjustments, etc.
 - b) Transportation of any HARDI® product to and from where the warranty work is performed.
 - c) Dealer travel time to and from the machine or to deliver and return the machine from the service workshop for repair.
 - d) Dealer traveling costs.
4. Parts defined as normal wearing items, (i.e. tires and V-belts) are not in any way covered under this warranty.
5. This warranty will not apply to any product which is altered or modified without the express written permission of HARDI® and/or repaired by anyone other than an Authorized Service Dealer.
6. Warranty is dependent upon the strict observance by the purchaser of the following provisions:
 - a) That this warranty may not be assigned or transferred to anyone.
 - b) That the Warranty Registration Certificate has been correctly completed by dealer and purchaser with their names and addresses, dated, signed and returned to the appropriate address as given on the Warranty Registration Certificate.
 - c) That all safety instructions in the operator's manual shall be followed and all safety guards regularly inspected and replaced where necessary.
7. No warranty is given on second-hand products and none is to be implied.



8. Subject to the following terms, conditions and contributions, HARDI® extends the warranty on polyethylene tanks (excluding fittings, lids and gaskets) to FIVE YEARS. To qualify for this extended warranty, the tank must be drained and flushed with fresh water after each day of use. HARDI®'s liability is limited to replacement of the tank, FOB our plant at no cost to the purchaser during the first twelve months; at 20% of the then current price during the second year ; at 40% during the third year ; at 60% during the fourth year ; and at 80% during the fifth year. This five year extended warranty is subject, in each instance, to the tank being inspected and approved for replacement or repair by HARDI® personnel before HARDI® will accept any liability hereunder.
9. Subject to the following terms, conditions, contributions, HARDI® extends the warranty on HARDI® diaphragm pumps (excluding wearing parts such as diaphragms, valves, etc.) to FIVE YEARS. To qualify for this extended warranty, the pump must be drained and flushed with fresh water after each day of use. HARDI®'s liability is limited to replacement of defective parts, FOB our plant at no cost to the purchaser during the first twelve months after date of purchase, at 20% of the then current retail price during the second year ; at 40% during the third year ; at 60% during the fourth year ; and at 80% during the fifth year. This five year extended warranty is subject, in each instance, to the pump being inspected and approved for replacement or repair by HARDI® personnel before HARDI® will accept any liability hereunder.
10. HARDI® reserves the right to incorporate any change in design in its products without obligation to make such changes on units previously manufactured.
11. The judgement of HARDI® in all cases of claims under this warranty shall be final and conclusive and the purchaser agrees to accept its decisions on all questions as to defect and to the exchange of any part or parts.
12. No employee or representative is authorized to change this warranty in any way or grant any other warranty unless such change is made in writing and signed by an officer of HARDI® at it's head office.
13. Any warranty work performed which will exceed \$400.00 MUST be approved IN ADVANCE by the Service Manager.
14. Any pump replacement must be approved in advance by the Service Manager.
15. Claims under this policy must be filed with HARDI® within thirty (30) days of work performed or warranty shall be void.
16. Parts requested must be returned prepaid within thirty (30) days for warranty settlement.
17. Warranty claims must be COMPLETELY filled out properly or will be returned.

DISCLAIMER OF FURTHER WARRANTY

THERE ARE NO WARRANTIES, EXPRESSED OR IMPLIED, EXCEPT AS SET FORTH ABOVE. THERE ARE NO WARRANTIES WHICH EXTEND BEYOND THE DESCRIPTION OF THE PRODUCT CONTAINED HEREIN. IN NO EVENT SHALL THE COMPANY BE LIABLE FOR INDIRECT, SPECIAL OR CONSEQUENTIAL DAMAGES (SUCH AS LOSS OF ANTICIPATED PROFITS) IN CONNECTION WITH THE RETAIL PURCHASER'S USE OF THE PRODUCT.