

NEW
COMMANDER
4400/6600 Instruction book

67021403 - Version 1.00

US - 08.2006

HARDI® reserves the right to make changes in design, material, or specification without notice thereof.
HARDI® and other product names are registered trademarks of HARDI® Inc. in the U.S. and in other countries.

1 - Welcome

Welcome letter	1
-----------------------------	----------

2 - Safety notes

Operator safety	1
------------------------------	----------

General info	1
--------------------	---

Local poison information center	3
--	----------

3 - Description

General info	1
---------------------------	----------

View	1
------------	---

View	2
------------	---

Sprayer use	2
-------------------	---

Roadworthiness	2
----------------------	---

Identification plates	3
-----------------------------	---

Frame	3
-------------	---

Tank	3
------------	---

LookAhead Liquid system	4
--------------------------------------	----------

General info - MANIFOLD system	4
--------------------------------------	---

Pump	4
------------	---

Valves and symbols	4
--------------------------	---

Suction valve = Blue symbols	4
------------------------------------	---

Pressure valve = Green symbols	4
--------------------------------------	---

Agitation valve	5
-----------------------	---

ChemFiller Vortex nozzle - Yellow label	5
---	---

Chemical container cleaning lever - Yellow label	5
--	---

ChemFiller	6
------------------	---

Diagram - LookAhead Liquid system	6
---	---

Diagram - LookAhead Liquid system with optional extras	7
--	---

LookAhead pressure control unit	7
---------------------------------------	---

Section control unit	8
----------------------------	---

Filters	8
---------------	---

EasyClean filter	8
------------------------	---

CycloneFilter	9
---------------------	---

Boom	10
-------------------	-----------

Boom Operator's manual	10
------------------------------	----

Boom configurations	10
---------------------------	----

Terminology	10
-------------------	----

Equipment	11
------------------------	-----------

Driving technique for SafeTrack	11
---------------------------------------	----

SafeTrack	11
-----------------	----

Platform	11
----------------	----

Tank level indicator	12
----------------------------	----

Remote pressure gauge	12
-----------------------------	----

ChemLocker	12
------------------	----

SafetyLocker	12
--------------------	----

Night Spraying Light (optional equipment)	13
---	----

External Cleaning Device (optional equipment)	13
---	----

Mudguards (optional equipment)	13
--------------------------------------	----

Table of contents

4 - Sprayer setup

General info	1
Unloading the sprayer from the truck.....	1
Pulling the sprayer at the tie down hooks	1
Jack up the sprayer.....	1
Before putting the sprayer into operation.....	2
Support jack (4400 model).....	2
Hydraulic support jack (6600 model).....	2
Mechanical connections	3
Drawbars - model 4400 and model 6600.....	3
Transmission shaft - Operator's safety.....	3
Transmission shaft - Installation	3
Hose package support.....	4
Hydraulic systems	5
General info.....	5
Hydraulic requirements	5
PARALIFT™ hydraulics.....	5
SafeTrack hydraulics	5
Open center hydraulics (optional equipment).....	6
FlexCapacity pump (optional - model 6600 only).....	6
FlexCapacity system specifications:	6
Electrical connections	7
Installation of control box - EFC control unit.....	7
Installation of control box - Hydraulics control unit.....	7
Installation of control unit brackets	7
Power supply.....	7
Road safety kit.....	8
Potentiometer connection.....	8
LookAhead Liquid system	8
CycloneFilter.....	8
Transport	9
Transport lock.....	9
Track width, axles and wheels	9
Altering the track width.....	9
Dual tire setup.....	10

5 - Operation

Boom	1
Safety info	1
Maneuvering of the FORCE™ boom	2
Alternative boom width	2
Boom support wheels	2
Maneuvering of the EAGLE™ SPC boom	3
Alternative boom width	3
LookAhead Liquid system	4
Filling of water	4
Filling through tank lid	4
Main Tank Quick Fill (optional equipment)	4
Flush Tank Quick Fill	5
Filling of clean water tank	5
Adjustment of EFC operating unit	5
Safety precautions - crop protection chemicals	6
Filling chemicals through tank lid	6
Filling chemicals by HARDI® ChemFiller	7
Agitation before re-starting spraying	8
Operating the control unit while spraying	8
Quick reference - Operation	9
Cleaning	10
General info	10
Cleaning and maintenance of filters	10
Use of flush tank and rinsing nozzles	11
Quick reference - Cleaning	12
Technical residue	12
Using the drain valve	13
Outside cleaning - Use of External Cleaning Device (optional equipment)	13
Work light selector switch	14
Spray Technique - see separate book	14
Optional extras - see separate books	14

Table of contents

6 - Maintenance

Lubrication	1
General info	1
Recommended lubricants	1
Trailer lubrication & oiling plan	1
Service and Maintenance intervals	2
10 hours service - Cyclone filter	2
10 hours service - EasyClean filter	2
10 hours service - In-Line filter (optional equipment)	3
10 hours service - Nozzle filters	3
10 hours service - Spraying circuit	3
50 hours service - Transmission shaft	3
50 hours service - Wheel bolts and nuts	3
50 hours service - Tire pressure	4
100 hours service - Check/tighten steering	4
250 hours service - Readjustment of the boom	4
250 hours service - Hydraulic circuit	4
250 hours service - Hoses and tubes	4
250 hours service - Wheel bearings	5
1000 hours service - Transmission shaft	5
1000 hours service - Wheel bearings	5
Occasional maintenance	6
General info	6
Pump valves and diaphragms replacement	6
Cone check/replacement for EFC operating unit	7
Cone check/replacement for EFC distribution valve	7
Level indicator adjustment	7
Level indicator cord replacement	8
Drain valve seal replacement	8
Nozzle tubes and fittings	8
Adjustment of 3-way-valve	9
Readjustment boom - general info	9
Wear bushing replacement on boom lift	10
Change of bulbs	10
Wear bushing replacement on steering	10
Shock absorbers	10
Shield replacement on transmission shaft	11
Replacement of transmission shaft cross journals	11
Change of tire	12
Off-season storage	13
Off-season storage program	13
Preparing the sprayer for use after storage	13

7 - Fault finding	
Operational problems	1
General info	1
Liquid system	2
Hydraulic system - Z model	3
Mechanical problems	4
Emergency operation - Liquid system	4
8 - Technical specifications	
Dimensions	1
Overall dimensions	1
Weight	1
Wheel and axle dimensions	1
Specifications	2
Pump model 463/6.5	2
Filters and nozzles	2
Temperature and pressure ranges	2
Power consumption	2
Tire pressure	2
Materials and recycling	3
Disposal of the sprayer	3
Electrical connections	3
Rear lights	3
Electrical specifications for boom and work light	3
Electrical connections for SPRAY II	4
EFC	5
HC5500	5
Charts	6
Force™ Boom hydraulics (2 fold)	6
Force™ Boom hydraulics (3 fold)	7
Eagle™ SPC Boom hydraulics - DH	8
Sprayer hydraulics	8
9 - Warranty	
Warranty policy and conditions	1

Table of contents

Welcome letter



Dear Owner,

Thank you for purchasing a HARDI® product and welcome to the ever-increasing family of HARDI® sprayer owners.

Our sprayers and accessories are rapidly becoming a familiar sight on North American farms. We believe that this results from growers becoming increasingly conscious of crop protection input costs and the vital need for cost effective spray application equipment.

Please take the time to thoroughly read the Operator's Manual before using your equipment. You will find many helpful hints as well as important safety and operation information.

Some of the features on your HARDI® sprayer were suggested by growers. There is no substitute for "on farm" experience and we invite your comments and suggestions. If any portion of this instruction book remains unclear after reading it, contact your HARDI® dealer or service personnel for further explanation before using the equipment.

For Product, Service or Warranty Information:

- Please contact your local HARDI® dealer.

To contact HARDI® directly:

- Please use the HARDI® Customer Service number: 1-866-770-7063

- Or send your email to CUSTSERV@hardi-us.com

HARDI® Inc.

HARDI® MIDWEST
1500 West 76th St.
Davenport, Iowa 52806
Phone: (563) 386-1730
Fax: (563) 386-1710

HARDI® GREAT LAKES
290 Sovereign Rd.
London, Ontario N6M 1B3
Phone: (519) 659-2771
Fax: (519) 659-2821

Visit us online at: www.hardi-us.com

HARDI® WEST COAST
8550 W. Roosevelt Avenue
Visalia, California 93291
Phone: (559)651-4016
Fax: (559) 651-4160

Sincerely,

A handwritten signature in black ink, appearing to read "Tom L. Kinzenbaw".

Tom L. Kinzenbaw
President

Operator safety



This symbol means DANGER. Be very alert as your safety is involved!



This symbol means WARNING. Be alert as your safety can be involved!



This symbol means ATTENTION. This guides to better, easier and safer operation of your sprayer!

General info

Note the following recommended precautions and safe operating practices.



Read and understand this instruction book before using the equipment. It is equally important that other operators of this equipment read and understand this book.



Local law may demand that the operator is certified to use spray equipment. Adhere to the law.



Wear protective clothing.



Rinse and wash equipment after use and before servicing.



Never service or repair the equipment while it is operating.



Always replace all safety devices or shields immediately after servicing.



Do not eat, drink or smoke while spraying or working with contaminated equipment.



Wash and change clothes after spraying.

Wash tools if they have become contaminated.



In case of poisoning, immediately seek medical advice. Remember to identify chemicals used.



Keep children away from the equipment.



If any portion of this instruction book remains unclear after reading it, contact your HARDI® dealer for further explanation before using the equipment.



Be careful not to hit people or surroundings when maneuvering the sprayer, especially when backing.



Slow down when driving in uneven terrain, as the machine might be in risk of turning over.

2 - Safety notes



Pressure test with clean water prior to filling with chemicals.



Disconnect electrical power before servicing and depressurize equipment after use and before servicing.



Do not attempt to enter the tank.



Do not go under any part of the sprayer unless it is secured. The boom is secure when placed in the transport brackets.



If an arc welder is used on the equipment or anything connected to the equipment, disconnect power leads before welding. Remove all inflammable or explosive material from the area.



Disconnect the cleaner and the water supply before the high pressure hose is disconnected. Never disconnect the hose if the machine is in operation.



The External Cleaning Device should not be used if important parts of the equipment have been damaged, including safety devices, high pressure hoses, etc.

Local poison information center



If you live anywhere in the United States, the following toll free number will connect you to your Local Poison Information Center.

PHONE NO. 1 - 800 - 222 - 1222



If you live outside the United States, find the number for the poison control center in your phone book and write it in the space below:

PHONE NO. _____ - _____ - _____



Keep a list, in the space provided below, of all the chemicals that you have in use.

1. _____

2. _____

3. _____

4. _____

5. _____

6. _____

7. _____

8. _____

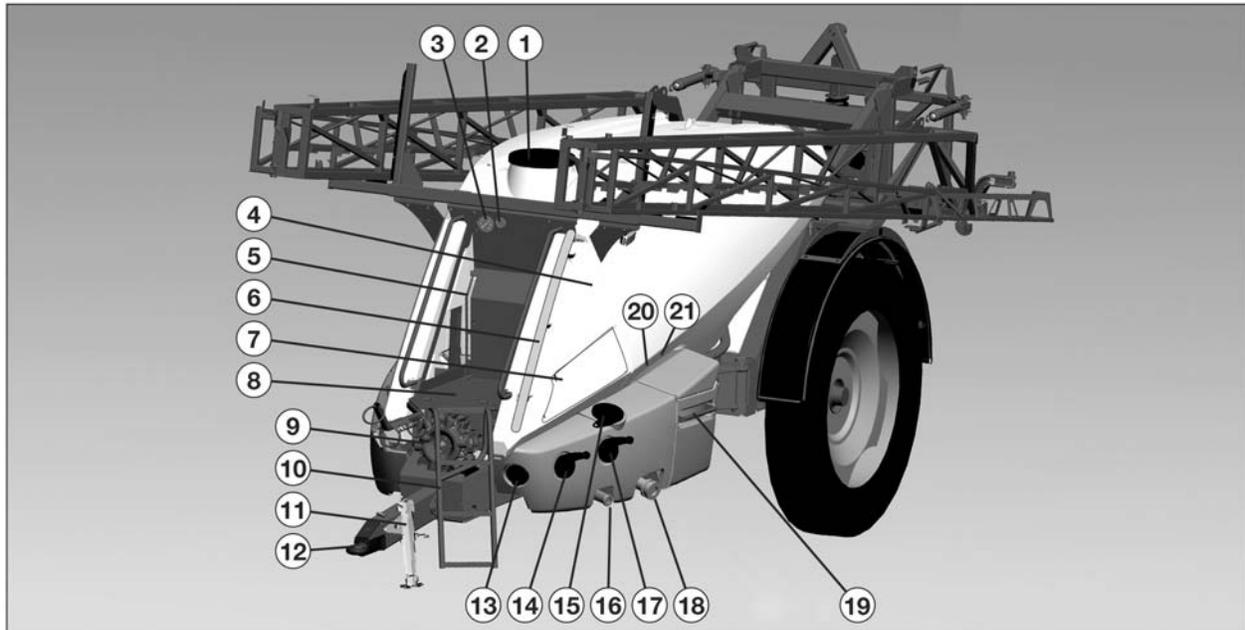
9. _____

10. _____

2 - Safety notes

General info

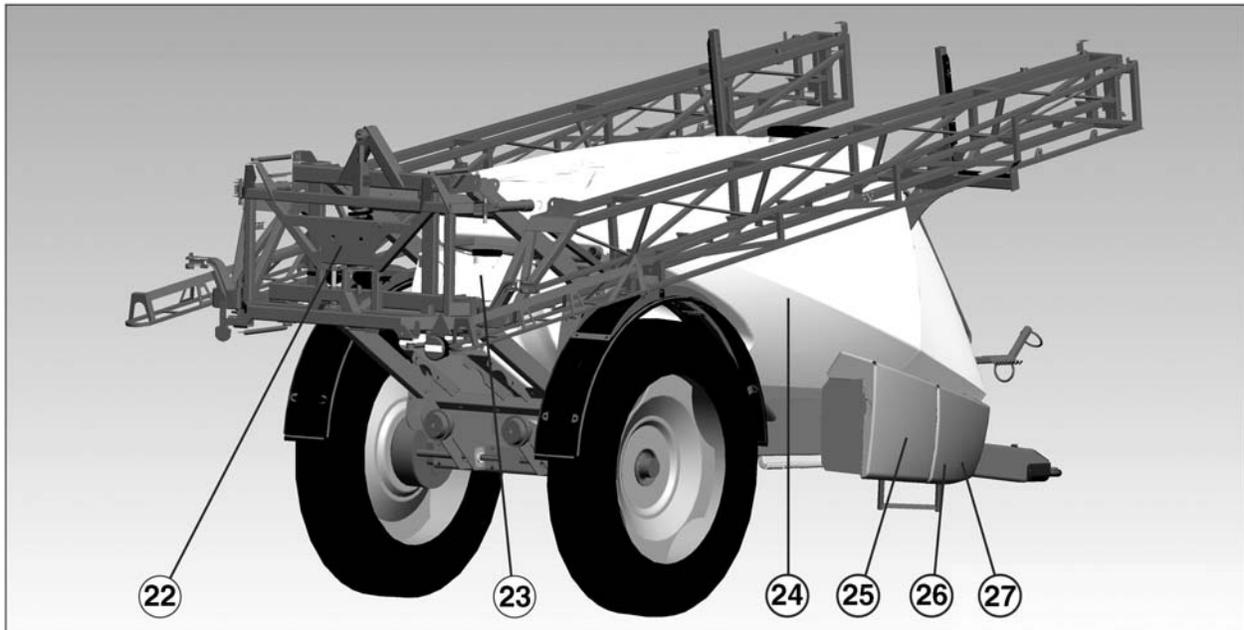
View



- | | |
|--|--|
| 1. Main tank lid | 12. Drawbar |
| 2. EasyClean filter clogging indicator | 13. Agitation/External Cleaning Device valve |
| 3. Spray pressure gauge | 14. Suction SmartValve |
| 4. Clean water tank | 15. EasyClean filter |
| 5. Flush tank level indicator | 16. Flush tank Quick Fill |
| 6. Main tank level indicator | 17. Pressure SmartValve |
| 7. SafetyLocker | 18. Main tank Quick Fill |
| 8. Platform | 19. ChemFiller |
| 9. Pump | 20. Lever for Chemcontainer cleaning |
| 10. Ladder | 21. ChemFiller Vortex nozzle valve |
| 11. Support jack | |

3 - Description

View



22. Distribution valves

23. Flush tank

24. Main tank

25. ChemLocker or FoamMarker tank

26. Hose reel for External Cleaning Device

27. CycloneFilter

Sprayer use

The HARDI® sprayer is for the application of crop protection chemicals and liquid fertilizers. The equipment must only be used for this purpose. It is not allowable to use the sprayer for other purposes. If no local law demands that the operator must be certified to use spray equipment, it is strongly recommended to be trained in correct plant protection and in safe handling of plant protection chemicals to avoid unnecessary risk for persons and the environment when doing your spray job.

Roadworthiness

When driving on public roads and other areas where the highway code applies, or areas where there are special rules and regulations for marking and lights on implements, you should observe these and equip implements accordingly.

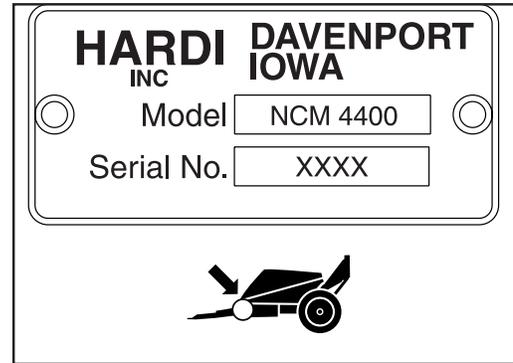


ATTENTION! Max. driving speed is 25 mph (40 km/h). Be aware that this may differ due to local law. Contact local authorities for information of max. driving speeds.

3 - Description

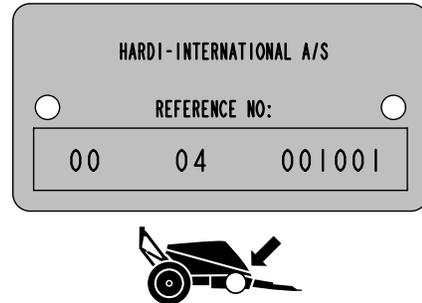
Identification plates

An identification plate fitted on the frame indicates producer name, model and serial number.



Frame, boom center frame and other main steel components have identification plates indicating type and part number. (not illustrated)

REFERENCE NO: is the main reference number of the complete machine



Frame

Very strong and compact frame which also has a strong chemical and weather resistant electrostatic powder coat. Screws, nuts, etc. have been DELTA-MAGNI treated to be resistant to corrosion.

Tank

The main tank made of impact-proof, UV-resistant and chemical resistant polyethylene, has a purposeful design with no sharp corners for easy cleaning. Nominal contents 1200 gal (4400 liters) or 1850 gal (6600 liters). A large, easy to read, tank contents indicator is placed beside the platform and is visible from the tractor cabin. The filling hole is placed so it can be accessed from the platform. This ensures an easy access for filling, cleaning of the tank, etc. The sprayer is also equipped with a flush tank and a clean water tank.

3 - Description

LookAhead Liquid system

General info - MANIFOLD system

All functions of the spray circuits are operated via the centrally situated MANIFOLD with color coded pictorial symbols for easy operation.

Pump

A diaphragm pump with 6 diaphragms, model 463, with easily accessible valves and diaphragms. Standard = 1000 r.p.m. (20 or 21 splines).

Valves and symbols

The valves at the MANIFOLD are distinguished by colored identification on the function labels. Symbols corresponding to every possible function of use are located on the discs for easy identification and operation. A function is activated by turning the handle towards the desired function.



ATTENTION! Only the functions in use should be open - always close remaining valves.



ATTENTION! If a MANIFOLD valve is too tight to operate - or too loose (= liquid leakage) - the valve needs to be serviced. Please see the section 'Maintenance' for further information.

Suction valve = Blue symbols

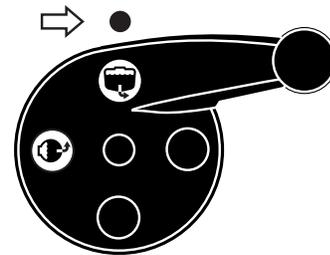
The active function is indicated by the indicator.



Suction from main tank



Suction from flush tank



Pressure valve = Green symbols

The active function is indicated by the indicator.



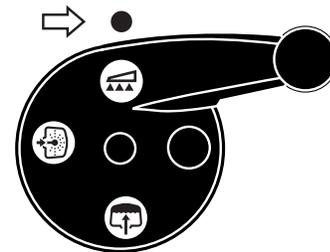
Return to main tank



Spraying



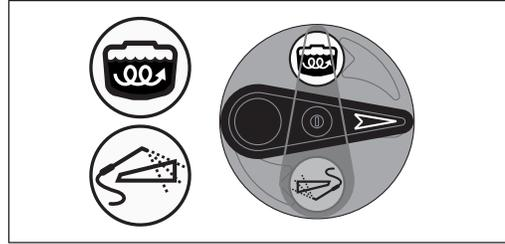
Internal tank cleaning



3 - Description

Agitation valve

With the adjustable Agitation valve, it is possible to combine spraying with a high volume rate at high pressure with agitation at same time. This is controlled continuously on the valve: The valve is marked with an arrow on the disc that indicates the amount of liquid that passes through the valve. If the handle is turned to a position near the tip of the arrow, then only a small amount of liquid is allowed to pass the valve, resulting in less vigorous agitation. Otherwise, if the handle is turned to a position in the wide end of the arrow, then a large amount of liquid will pass the valve, resulting in a more vigorous agitation.



Adjustable Agitation



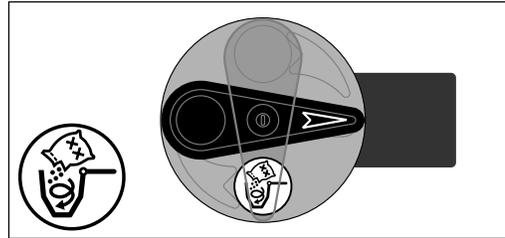
External Cleaning Device
(optional equipment)

ChemFiller Vortex nozzle - Yellow label

This valve activates the Vortex flushing of the ChemFiller. The valve is situated behind the ChemFiller and is only visible when ChemFiller is folded down in operating position.



Start Vortex



Chemical container cleaning lever - Yellow label

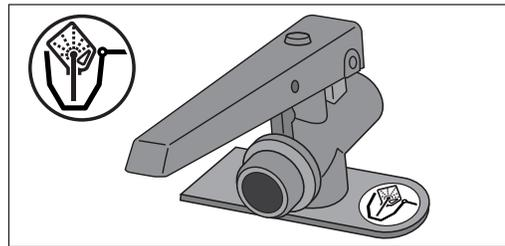
The lever is used for two purposes:

When ChemFiller lid is open: For cleaning empty containers. Put container over the rinsing nozzle in the middle of the ChemFiller so that the nozzle is inside the container. By squeezing the Chemical Container Cleaning lever, the rinsing nozzle in the middle of the ChemFiller is activated.

When ChemFiller lid is closed: Use the Chemical Container Cleaning lever to rinse the hopper after filling of chemicals has ended.



Chemical container cleaning



DANGER! Do not press lever unless the multi-hole nozzle is covered by a container to avoid spray liquid hitting the operator.

3 - Description

ChemFiller

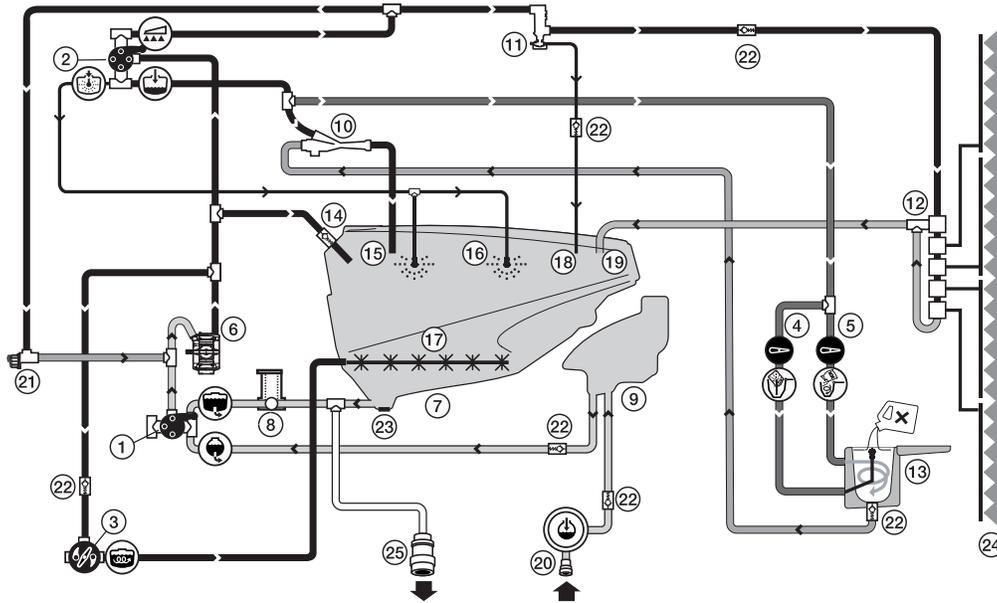
The ChemFiller is situated in the working zone on the sprayer's left side, just behind the MANIFOLD valves. The ChemFiller should be folded down when being used. Grab the handle, unlock it by pushing the lever (just below the handle's left side) forward, and pull the ChemFiller toward yourself.

To retract the ChemFiller after use, unlock it by pushing the lever (just below the handle's left side) forward, and push the ChemFiller back into storage position. The ChemFiller is locked into the storage position when a click is heard.

When folded down in operating position, a lever for chemical container cleaning and a valve for the ChemFiller Vortex nozzle are visible on the backside of the ChemFiller.

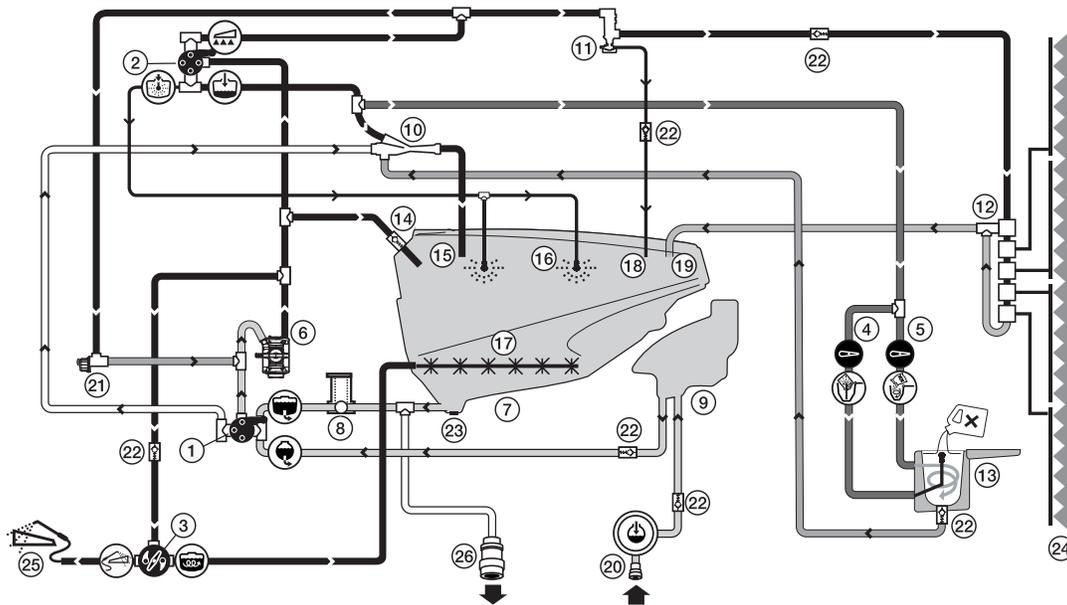


Diagram - LookAhead Liquid system



- | | |
|--------------------------------------|-------------------------------------|
| 1. Suction SmartValve | 14. SafetyValve |
| 2. Pressure SmartValve | 15. Ejector filling inlet |
| 3. Agitation valve | 16. Internal tank cleaning nozzles |
| 4. Chemical container cleaning lever | 17. Agitation |
| 5. ChemFiller Vortex nozzle | 18. Return line for boost function |
| 6. Pump | 19. Return from distribution valves |
| 7. Main tank | 20. Flush tank Quick Fill |
| 8. EasyClean filter | 21. PressureControl valve |
| 9. Flush tank | 22. One-way valve |
| 10. Ejector | 23. Drain valve |
| 11. CycloneFilter | 24. Sprayer boom |
| 12. Section valves | 25. Main tank Quick Fill |
| 13. ChemFiller | |

Diagram - LookAhead Liquid system with optional extras



- | | |
|---|-------------------------------------|
| 1. Suction SmartValve | 14. SafetyValve |
| 2. Pressure SmartValve | 15. Ejector filling inlet |
| 3. Agitation/External Cleaning Device valve | 16. Internal tank cleaning nozzles |
| 4. Chemical container cleaning grip | 17. Agitation |
| 5. ChemFiller Vortex nozzle | 18. Return line for boost function |
| 6. Pump | 19. Return from distribution valves |
| 7. Main tank | 20. Flush tank Quick Fill |
| 8. EasyClean filter | 21. PressureControl valve |
| 9. Flush tank | 22. One-way valve |
| 10. Ejector | 23. Drain valve |
| 11. CycloneFilter | 24. Sprayer boom |
| 12. Section valves | 25. External Cleaning Device |
| 13. ChemFiller | 26. Main tank Quick Fill |

LookAhead pressure control unit

The system is based on EFC - Electrical Fluid Control. The LookAhead control unit is constructed of modules and is electrically controlled via a remote control box.

The built-in HARDI-MATIC ensures a constant volume per acre of the liquid (gpa) at varying forward speed within the same gear when the number of P.T.O. revolutions are between 650-1100 r.p.m. (pump 1000 r.p.m.).



ATTENTION! The LookAhead system is only activated while spraying if supported by the HC 5500 spray controller.

3 - Description

Section control unit

EFC - Electrical Fluid Control. The ON/OFF is linked to the section valves, which results in a very quick response to ON/OFF. The operating unit is constructed of modules and is electrically controlled via a remote control box.

Filters

An EasyClean suction filter is fitted in the working zone near the Smart Valves. It has a built-in valve that closes when the filter is opened for inspection or cleaning.

A Cyclone pressure filter is fitted to the sprayer's right side. It has a built-in self-cleaning function.

In-line pressure filters can be fitted at each section as an option.

Nozzle filters are fitted at each nozzle.

All filters should always be in use and their function checked regularly. Pay attention to the correct combination of filter and mesh size. The mesh size should always be less than the flow average of the nozzles in use.

EasyClean filter

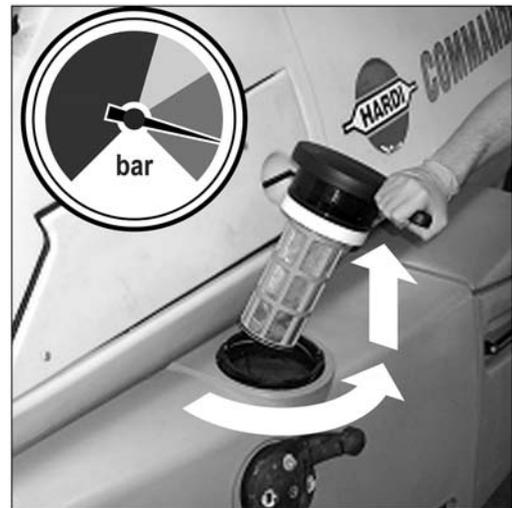
The EasyClean filter is fitted in the working zone near the Smart Valves. It has a built-in valve that automatically closes when the filter is opened for inspection and cleaning. To open filter, turn it counter-clockwise and pull it up, like shown in picture.

Beside the spray pressure gauge on the platform, an EasyClean clogging indicator is located.

Green indicator: No cleaning necessary.

Yellow indicator: It is possible to finish an ongoing spraying job and then clean filter afterwards.

Red indicator: Clean EasyClean filter immediately, as filter is clogged.



3 - Description

CycloneFilter

With the CycloneFilter, the impurities that exist in the spray liquid will by-pass the filter and be recirculated back to the tank via the return flow.

Function diagram

1. Filter lid
2. From pump
3. To boom
4. Return to tank
5. Return valve

Valve (5) has three positions marked with small dots on the lever:

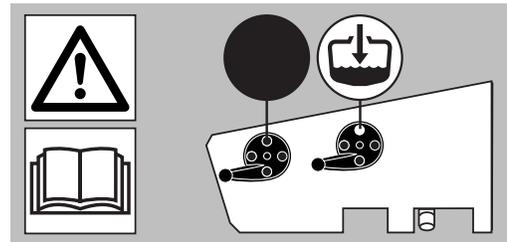
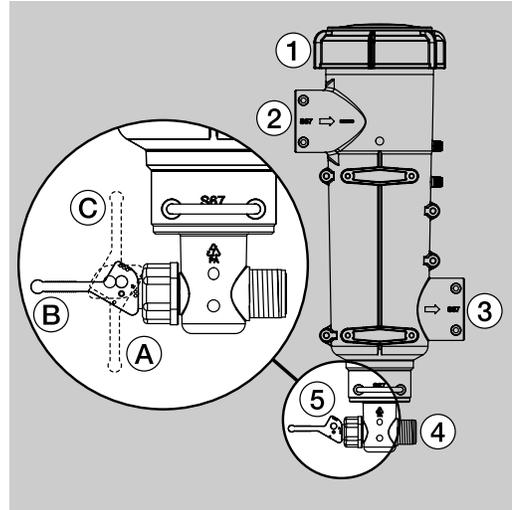
Position A (Marked with 1 dot): There is no return flow. Position is used when flushing the boom if there is spray liquid in the main tank. Also used when high spraying volume is required.

Position B (Marked with 2 dots): Normal spraying position. With return flow to prevent clogging the filter when spraying. Position is used when flushing the boom if the main tank is empty.

Position C (Marked with 3 dots): Flushing position, which is used if filter is clogged. Lift and hold the lever to use this position which largely increases return flow and cleans the filter.



DANGER! Before opening the Cyclone filter, the Suction SmartValve must always be turned to the unused position and the pressure SmartValve to "Main tank" (both levers pointing forward)! If not, spraying liquid can hit you when opening the filter, and drain from the tank!



3 - Description

Boom

Boom Operator's Manual

The New Commander is available with either an EAGLE™ SPC series boom or a FORCE™ series boom. A separate "Boom Operator's Manual" is supplied with your sprayer and contains detailed information on boom safety, set-up, operation and maintenance.



DANGER! Important information on Safety, Operation and Maintenance specific to your boom configuration is detailed in the "Boom Operator's Manual" supplied with your sprayer. It must be read and fully understood by anyone intending to operate this equipment. Failure to do so could result in serious personal injury or death.

Boom configurations

The EAGLE™ SPC boom is available in 80', 88', 90' and 100' working widths. All EAGLE™ SPC booms have bi-fold wings.

The FORCE™ boom is available in 80', 88', 90', 100', 120' and 132' working widths. The 80' - 90' FORCE™ booms have bi-fold wings, while the 100' - 132' FORCE™ booms have tri-fold wings.

Outer sections on both EAGLE™ and FORCE™ booms incorporate spring loaded breakaways.

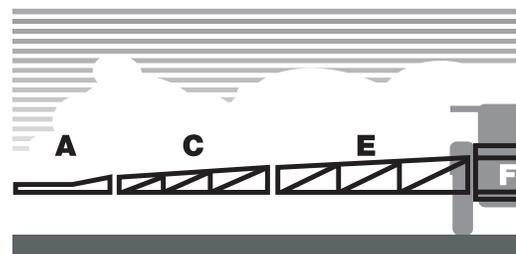
FORCE™ booms can be used in half-folded position and EAGLE™ booms can be used in single side folded position.

Full working width	FORCE™ 1/2 folded	EAGLE™ Single side folded
80' (24 m)	40' (12 m)	45' (14 m)
88' (27 m)	45' (14 m)	48' 3" (15 m)
90' (28 m)	50' (15 m)	50' (15 m)
100' (30 m)	40' (12 m)	55' (17 m)
120' (36 m)	50' (15 m)	
132' (40 m)	50' (15 m)	

Terminology

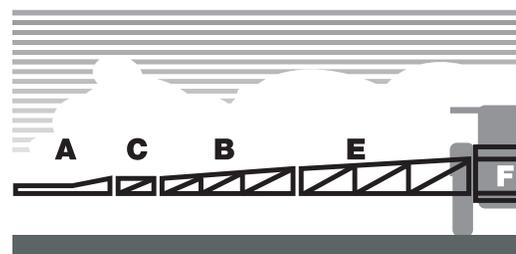
For bi-fold booms, the terminology is as follows:

- A - Breakaway section
- C - Outer section
- E - Inner section
- F - Center section



For tri-fold booms, the terminology is as follows:

- A - Breakaway section
- B - Intermediate section
- C - Outer section
- E - Inner section
- F - Center section



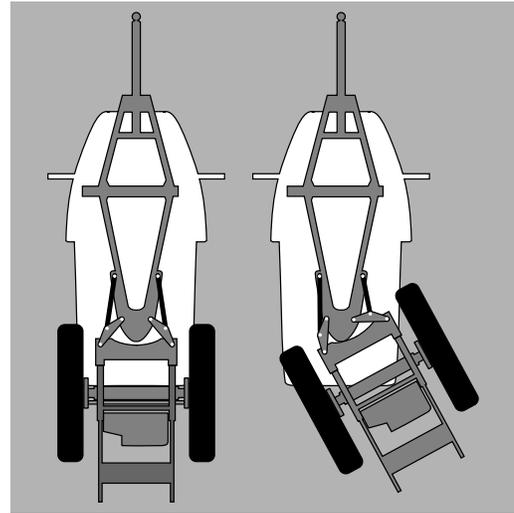
Equipment

Driving technique for SafeTrack

This articulated trailer behaves differently than a normal trailer. In tracking position the vehicle's center of gravity is displaced forward compared to the vehicle center line of a normal trailer. Compared to a conventional trailer with steering drawbar, this articulated trailer has increased stability when turning, especially when turning on hill-sides.

To avoid overbalancing, pay attention to these guidelines:

1. Avoid sudden, tight turns.
2. Slow down before entering a curve or turning, and drive with a constant, low speed during the turn.
3. Never slow down too fast, never brake heavily and never stop suddenly in a curve, or when turning on a hillside, when the sprayer is articulated.
4. Be careful when turning on uneven ground.
5. Set the track width as wide as possible.
6. The proper function of the hydraulic system is essential to obtain good stability.



DANGER! No persons are allowed in the operations area of the sprayer when steering is unlocked!



WARNING! Never articulate steering when boom is in transport position.

SafeTrack

Please see separate "HC5500 Controller" instruction book for track calibration and operation.

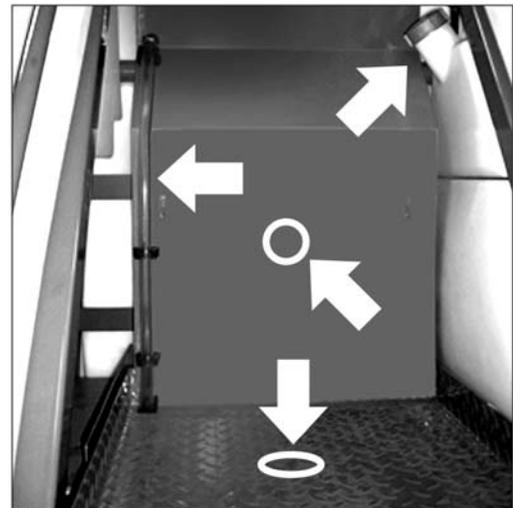
Platform

To get access to the platform, pull and tilt the ladder down. In retracted position the ladder is secured by a rubber stop.

Hydraulic, electrical and MANIFOLD components are situated underneath the platform floor. By lifting the platform floor, these components are accessible. Also, the clean water tank is integrated to the side of the platform.

The platform gives access to the clean water tank lid and the main tank lid. Electrical components are situated behind the cover located at the side facing the main tank. The pressure gauge and level indicator for the flush tank are visible on the same side.

ATTENTION! Always raise up the ladder before driving.



3 - Description

Tank level indicator

The actual tank level in the main tank can be observed on the tank level indicator. The scale is displayed in US gal. or Liters (certain countries).



Remote pressure gauge

The remote pressure gauge is integrated in the platform. This gauge measures the working pressure in the boom tubes as close to the nozzles as possible.

The outputs stated in the nozzle charts are always based on the pressure measured at the nozzle. Always adjust pressure when calibrating and spraying according to readings at the remote pressure gauge.



ChemLocker

A ChemLocker for storage of chemical containers etc. is mounted on the sprayer's right side.

Max. load 220 lbs. (100 Kgs.)



SafetyLocker

The locker is integrated to the clean water tank and is accessible just above the SmartValves. It is for the purpose of storing non-contaminated protective gear, soap for hand washing etc. The locker is split in two compartments for the separation of clean clothes from gloves to avoid risk of contamination.



WARNING! Although this locker is meant for storing nontoxic items, it must never be used for storing food, beverage or other things meant for consumption.



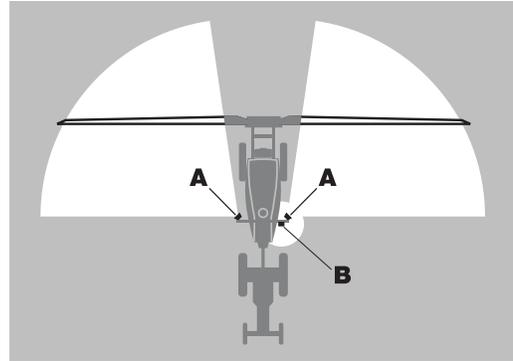
3 - Description

Night Spraying Light (optional equipment)

The 2 boom light lamps (A) are mounted to the railing of the platform (one at each side) and are positioned to illuminate both boom wings. The work light lamp (B) is also mounted to the railing of the platform above the MANIFOLD valves. This lamp is positioned to lighten the HARDI® ChemFiller and the MANIFOLD system.



ATTENTION! It is recommended to switch OFF the rear lights of the tractor in order to save power consumption and to avoid reflection. Power supply is via the 7-pin socket. Please see the Installation Instruction in the part Technical specifications.



External Cleaning Device (optional equipment)

This equipment comprises of a hose reel and spray gun. To get access to the External Cleaning Device, open the door on the sprayers right side.



WARNING! This cleaner produces a high pressure. Incorrect use may result in personal injuries!



DANGER! For the safety of yourself and others, the following rules should always be observed:

Never point the water jet at people, animals, electrical installations or other sensitive objects.

Never try to clean clothing or footwear which you or other people wear.

Never work with bare feet or sandals.

It is recommended to wear goggles during the work.

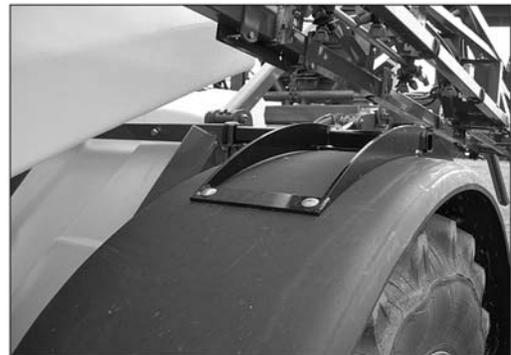
It is recommended that the user or anyone near the cleaning place protects himself against particles bouncing up during the cleaning.

Flushing handle and nozzle tubes are influenced by a back-force when the handle is released during operation - therefore always hold on to the insulation on top of the spray gun with one hand, and on to the pistol grip with the other hand.



Mudguards (optional equipment)

Mudguards can be fitted at the trailer wheels by means of a supporting frame which is slid into a mounting on the rear-end of the frame.

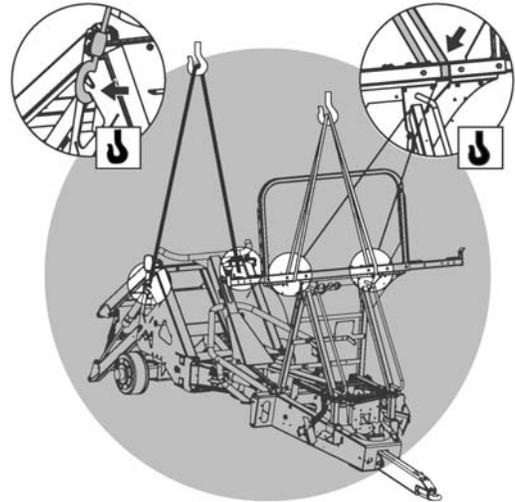


3 - Description

General info

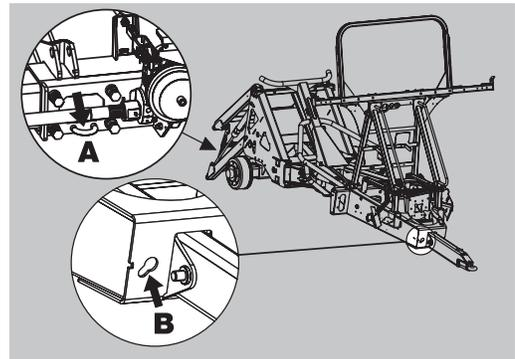
Unloading the sprayer from the truck

When unloading with an overhead lifting device, please observe the lifting points as shown in the picture, and make sure that the straps or belts used for lifting are strong enough.



Pulling the sprayer at the tie down hooks

For moving the sprayer or loading it to e.g. a truck, it can be pulled using the hooks at the rear-end (A) or a hook can be fastened into the hole in the front end of the sprayer (B).

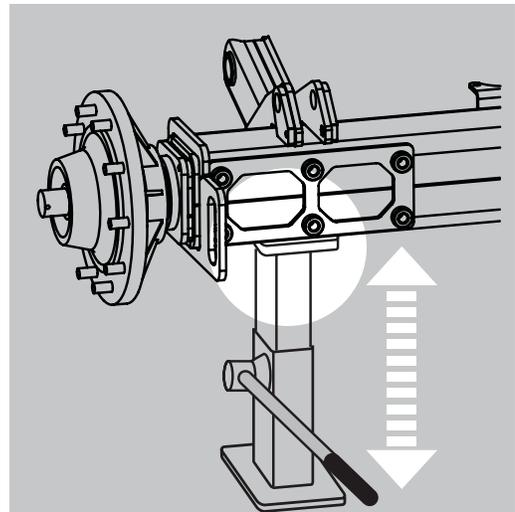


Jack up the sprayer

When the sprayer needs wheel mounting, wheel changing or wheel bearing changing etc. then jack up the sprayer under the axle as shown.



DANGER! Be sure to place sprayer on level and firm ground to avoid sprayer falling down from the jack.



4 - Sprayer setup

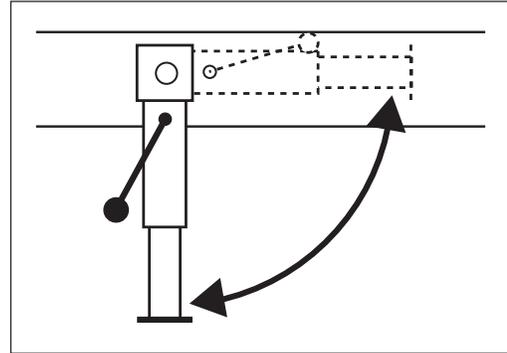
Before putting the sprayer into operation

Although the sprayer has been applied with a strong and protective surface treatment on steel parts, bolts etc. in the factory, it is recommended to apply a film of anticorrosion oil (e.g. CASTROL RUSTILLO or SHELL ENSIS FLUID) on all metal parts in order to avoid chemicals and fertilizers discoloring the enamel. If this is done before the sprayer is put into operation for the first time, it will always be easy to clean the sprayer and keep the enamel clean for many years. This treatment should be carried out every time the protection film is washed off

Support jack (4400 model)

The support jack is stored in retracted position and secured by the spring loaded lynch pin when the sprayer is attached to the tractor.

To retract the support jack: Lift the jack, then pull the lynch pin and tilt up the support jack until the lynch pin “clicks” into the upper locking hole. Then push the crank handle down and turn it so the handle will rest on the support jack.



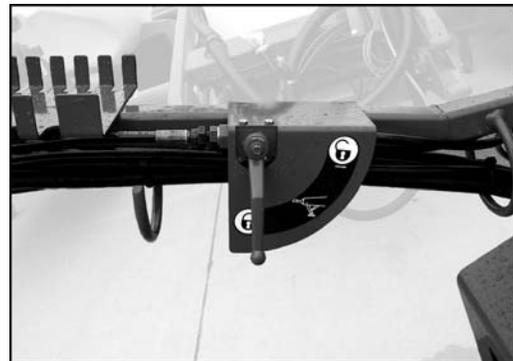
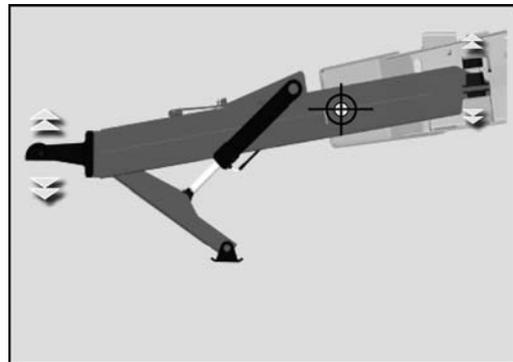
Hydraulic support jack (6600 model)

The drawbar on the Commander 6600 is equipped with a hydraulic support jack. The hydraulic valve to lock or unlock the support jack is located on the hose bracket in front of the platform.

Connect the hydraulic support jack hoses to a double acting hydraulic outlet on the tractor.

To operate, turn the hydraulic valve to the “unlocked” position and activate the tractor hydraulics to raise or lower the support leg to the desired height. Switch the hydraulic hoses at the tractor outlet if you don’t like the direction required to raise or lower the support leg.

For transport, raise the support leg all the way up and turn the hydraulic valve to the “locked” position.



DANGER! Make sure the hydraulic valve is “locked” and pressure has been relieved from the hydraulic hoses before disconnecting the hydraulic support jack hoses from the tractor.



DANGER! Hydraulic leaks: Never use your fingers to locate a leak in any part of the hydraulic system. Due to high pressure, hydraulic oil may penetrate the skin.



WARNING! The support leg must be fully retracted and locked before moving the sprayer.

Mechanical connections

Drawbars - model 4400 and model 6600

A swivel hitch drawbar is the only available drawbar on both the 4400 and 6600 models. The 4400 model uses a rigid drawbar, while the 6600 model uses a fully suspended drawbar with rubber dampers built into the chassis. Both are fully installed at the factory and need no further adjustment.

Transmission shaft - Operator's safety

1. Always STOP ENGINE before attaching the transmission shaft to tractor P.T.O. - most tractor P.T.O. shafts can be rotated by hand to facilitate spline alignment, when engine is stopped.
2. When attaching the shaft, make sure that the snap lock is FULLY ENGAGED - push and pull shaft until it locks.
3. Always keep protection guards and chains intact and make sure that it covers all rotating parts, including CV-joints at each end of the shaft. Do not use without protection guard.
4. Do not touch or stand on the transmission shaft when it is rotating - safety distance: 5' (1.5 meter).
5. Prevent protection guards from rotating by attaching the chains allowing sufficient slack for turns.
6. Make sure that protection guards around tractor P.T.O. and implement shaft are intact.
7. Always STOP ENGINE and remove the ignition key before carrying out maintenance or repairs to the transmission shaft or implement.

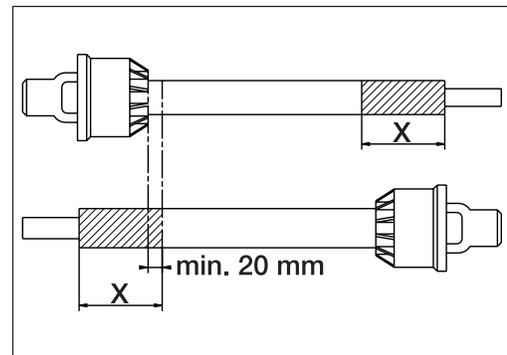


DANGER! ROTATING TRANSMISSION SHAFTS WITHOUT PROTECTION GUARDS ARE FATAL.

Transmission shaft - Installation

First installation of the transmission shaft is done in the following way:

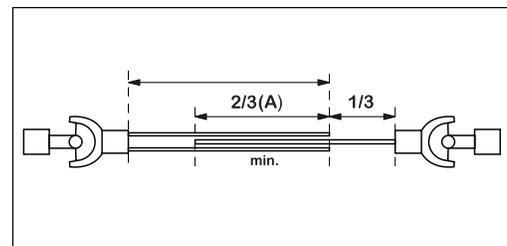
1. Attach sprayer to tractor and set sprayer height in the position with shortest distance between the tractor and sprayer pump P.T.O. shafts.
2. Stop engine and remove ignition key.
3. If transmission shaft must be shortened, the shaft is pulled apart. Fit the two shaft parts at tractor and sprayer pump and measure how much it is necessary to shorten the shaft. Mark the protection guards.



WARNING! The shaft must always have a minimum overlap of 2/3 the length.

Pump with 21 splines/1000 r.p.m.

The shaft must always have an overlap (A) of minimum 2/3 of the length.

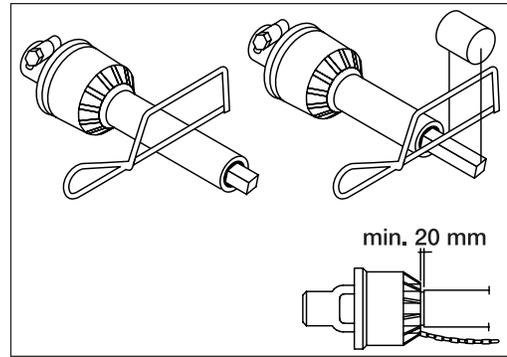


4 - Sprayer setup

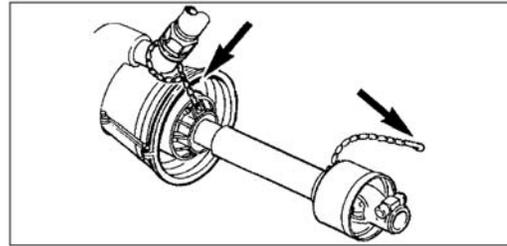
4. The two parts are shortened equally. Use a saw, and file the profiles afterwards to remove burrs.
5. Grease the profiles and assemble male and female parts again.
6. Fit the shaft to tractor P.T.O. and sprayer pump shaft.



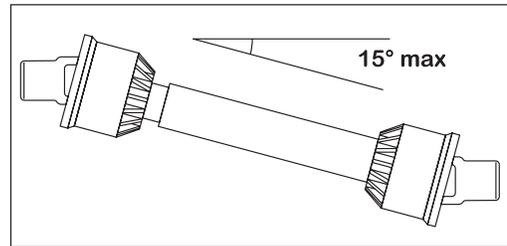
ATTENTION! Attach female part (marked with a tractor) towards tractor!



7. Fit the chains to prevent the protection guards from rotating with the shaft.

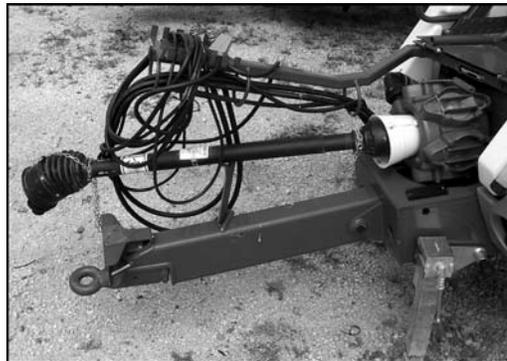


8. To ensure long life of the transmission shaft, try to avoid working angles greater than 15°.



Hose package support

To prevent hoses and wiring from being damaged by the tractor wheels, P.T.O. shaft etc., all hoses, cables and wires are held by the hose bracket fitted to the sprayer platform. Check that the length of the hoses and cables are sufficient for tight turns.



Hydraulic systems

General info

Ensure that snap couplers are clean before connection!

After having operated the boom and the system has been filled with oil, check tractor's hydraulic oil level and top up if necessary.



DANGER! Test of the hydraulic system should be done very cautiously. There may be air trapped in the system which can cause violent movements of the boom.



DANGER! Hydraulic leaks: Never use your fingers to locate a leak in any part of the hydraulic system. Due to high pressure, hydraulic oil may penetrate the skin.

Hydraulic requirements

The hydraulic system requires a double acting hydraulic outlet. The hydraulic hoses are marked with arrows and colored tie straps to indicate direction of oil flow. Red tie strap = pressure. Green tie strap = Return to tank. The hoses must be hooked up to the correct outlet for the hydraulics to function properly (pressure hose to pressure outlet, return hose to tank outlet).

Model 6600 requires an additional double acting hydraulic outlet to operate the hydraulic support jack. The optional FlexCapacity pump also requires a double acting hydraulic outlet.

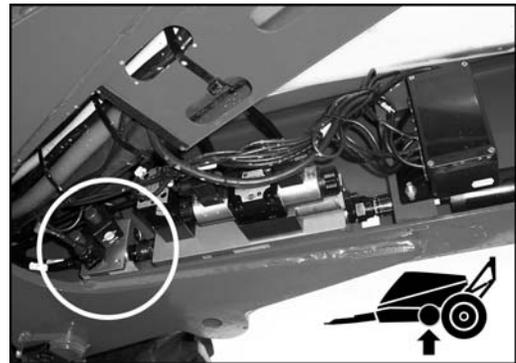
The hydraulic system requires an oil flow between 3 - 11 gal/min. (10 and 40 l/min) and a min. pressure of 2500 p.s.i. (170 bar). The system has a built-in flow regulator that maintains constant speed on hydraulic movements.



ATTENTION! When the hydraulic hoses are connected properly and hydraulic pressure is established, the SafeTrack lock will disengage after the HC 5500 is powered up. If not, the hydraulic hoses need to be reversed in the outlets.

PARALIFT™ hydraulics

This PARALIFT™ hydraulic block manages hydraulic pressure for the PARALIFT™ and boom functions. On picture it is viewed from below the main tank.



SafeTrack hydraulics

This steering hydraulic block manages hydraulic pressure for the steering functions.



4 - Sprayer setup

Open center hydraulics (optional equipment)

The open center hydraulics block is needed if the tractor uses open center hydraulics and/or if load sensing will be used.

The valve (1) on the side of the block is factory set for open center hydraulics, but if closed center hydraulics will be used in combination with load sensing, then screw in the valve.

Certain tractor models are able to use Load Sensing without connecting an external sensing line. But if optimal sensing control pressure cannot be obtained, an external sensing line needs to be mounted (3). Please consult your tractor dealer for correct setup and correct connection.

Before operating the hydraulics, the valve should be adjusted according to the specific tractor model. If you have doubt about which type of hydraulic system your tractor is equipped with, please consult your tractor dealer.

Schedule with combinations of settings for flow element and circuit value:

Valve no.	1	2	3 (LS port)
Open center	out	out	Not conn.
Closed center	in	in	Not conn.
Load sensing (LS)	in	out*	Connected

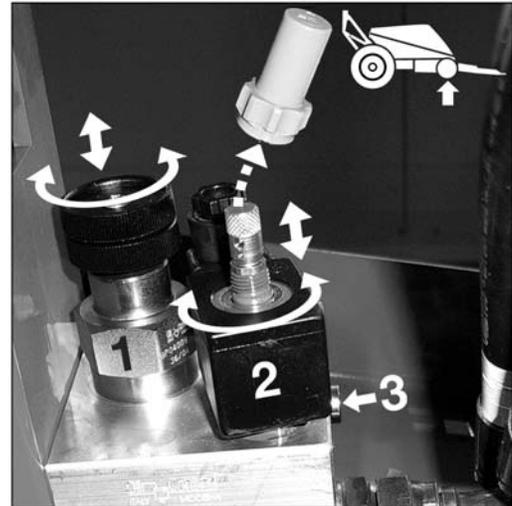
*if tractor requires pressure relief then contact your tractor dealer for further advise.



WARNING! Always be sure to fully extract or retract the open/closed center selection valve (1). Failure to do so can result in damages to vital pump parts.



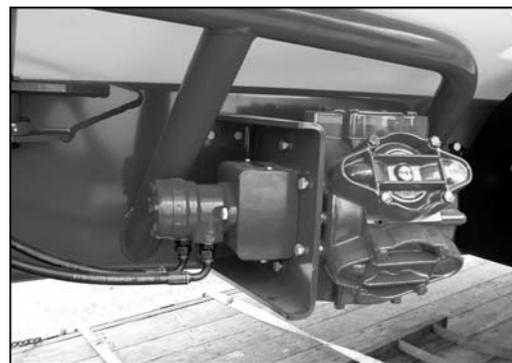
WARNING! It is of essential importance that connectors on sensing line are kept totally clean. Failure to do so can result in impurities entering the pump and thereby cause damages to vital pump parts.



FlexCapacity pump (optional - model 6600 only)

The FlexCapacity pump system incorporates a second standard 463 fluid pump mounted to the right side of the frame. The second pump is driven by a hydraulic motor which is powered by the tractor's auxiliary hydraulic system and so can be easily activated remotely.

Connect the hydraulic lines (routed along the frame and hose bundle support bracket) to a free auxiliary hydraulic outlet at the rear of the tractor. Make sure to connect the pressure and return lines correctly (which are clearly marked for positive identification).



FlexCapacity system specifications:

	Pump volume	Agitation Volume	Spray Volume
All flow directed to boom:	146 gpm (552 L/min)	0 gpm (0 L/min)	133 gpm (504 L/min)
Maximum agitation:	146 gpm (552 L/min)	53 gpm (200 L/min)	80 gpm (304 L/min)

Electrical connections

Installation of control box - EFC control unit

Find a suitable place in the tractor's cabin. Best recommended placement is to the right of the driver seat and in combination with the Hydraulics control unit. It should be secured from movement.



ATTENTION! Tractor driver's seat is the intended working place during operation.



Installation of control box - Hydraulics control unit

Find a suitable place in the tractor's cabin. Best recommended placement is to the right of the driver seat and in combination with the SPRAY control box. It should be secured from movement.

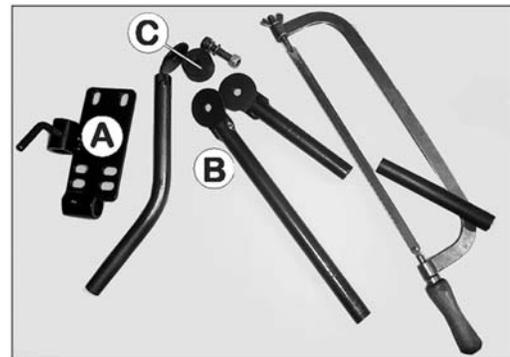


Installation of control unit brackets

The supplied tractor pillar bracket (A) has a hole spacing of 3.9 in. (100mm) and 4.7 in. (120 mm). Check tractor instructions manual for information regarding attachment points.

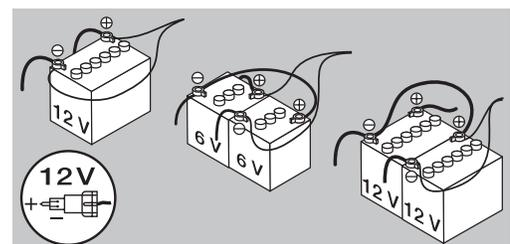
Three tubes (B) are supplied. One, two or all 3 may be used. They can be bent and shortened. A spacer (C) is also supplied to allow further attachment possibilities. Find the best solution for your tractor or vehicle.

Tube (B) plate is staggered, so if correctly orientated, all boxes will line up.



Power supply

Power requirement is 12V DC. Note polarity! The wires must be at least 10 awg. (4.0 mm²) to ensure a sufficient power supply. For the operating unit, the tractor circuit should have an 8 Amp fuse. The supplied power connector is standard on most newer tractors. If using a tractor with a different power connector, it is necessary to disassemble the connector and attach the wires to the actual tractor connector.



4 - Sprayer setup

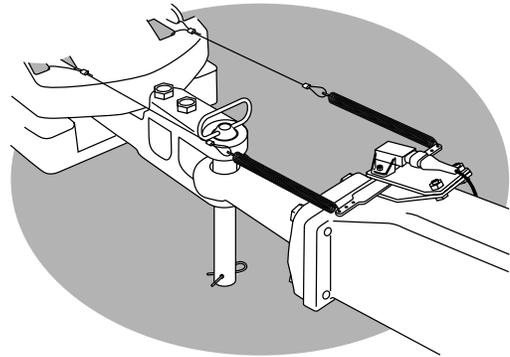
Road safety kit

Connect plug for rear lights to the tractor's 7-pin socket, and check function of rear lights, stop lights and direction indicators on both sides before driving.

The wiring is in accordance with ISO 1724. See section in "Technical specifications".

Potentiometer connection

The potentiometer must be connected to the tractor with the two supplied springs. To ensure high precision, try to keep the springs parallel and horizontal.



LookAhead Liquid system

CycloneFilter

Standard filter size is 80 mesh. Filters of 50 and 100 mesh are available and can be changed by opening the filter top. Check condition of O-rings and lubricate if necessary, or replace if damaged, before reassembly.



DANGER! Suction SmartValve must be turned to the unused position and the pressure SmartValve must be turned to "Main tank" (both levers pointing forward) before opening the Cyclone filter! If not, spraying liquid can hit you when opening the filter and drain from the tank!



Transport

Transport lock

The transport position can be set independently to obtain different transport heights.

To change position:

1. Lift and unfold inner sections until lock is disengaged.
2. Lower the boom completely.
3. Loosen and remove the two bolts, which keep the parts (X) and (Y) assembled.
4. Reassemble (X) and (Y) according to desired hole combination.



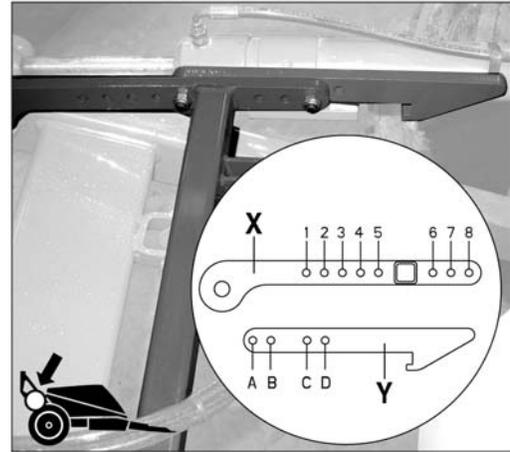
ATTENTION! Always use both bolts to assemble the lock. The setting must be identical on both sides.



ATTENTION! The rear settings must correspond to the front settings so the boom is resting on the front as well as rear brackets.



WARNING! The max. transport height must never exceed 13' 6" (4.0 M). Always measure the actual total height and choose settings not exceeding 13' 6".



Track width, axles and wheels

Altering the track width

The track width of the adjustable axles on the 4400 and 6600 models can be infinitely adjusted from 60" to 88".

1. Measure the current track width (center RH tire to center LH tire). Each side must be extended or retracted half the desired alteration.
2. Attach the sprayer to tractor and engage tractor parking brake.
3. Place stop wedges in front of, and behind RH wheel. Jack up LH wheel, support and secure sprayer body.
4. Loosen bolts (A) for LH wheel axle.
5. Extend or retract the axle.
6. Tighten the clamp bolts (A) to a torque of 290 Ft/lb (390 Nm).
7. Repeat the procedure on RH wheel.
8. Check if the distance from center of tire to center of rear frame is equal at RH and LH.
9. Retighten bolts and wheel bolts to specified torque after 8 hours of work.

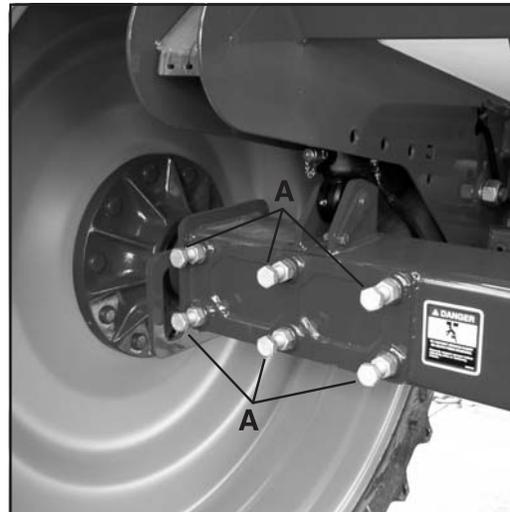
See "50 hours service - Wheel bolts and nuts" in the "Maintenance" section for proper torque and tightening sequence of wheel hubs to rims.



WARNING! Securely support the sprayer during axle adjustments. Never attempt to adjust axles with liquid in the tank. Always block wheels on opposite side when adjusting axles.



WARNING! Place a jack under the axle and lift the wheel to remove load from the clamps before tightening the clamp bolts to the specified torque.



4 - Sprayer setup

Dual tire setup

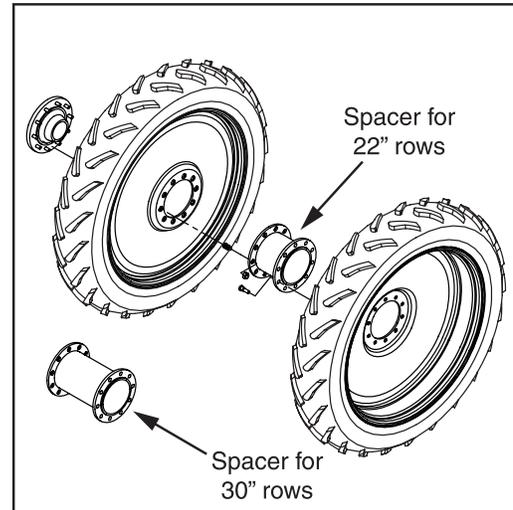
Two different dual tire kits are available for the COMMANDER:

22" row spacing (88"/132"): HARDI® ref. no. 70059503

30" row spacing (60"/120"): HARDI® ref. no. 70059603

Only 320/90 R50 tires may be used for duals.

1. Attach the sprayer to tractor and engage tractor parking brake.
2. Place stop wedges in front of, and behind RH wheel. Jack up LH wheel, support and secure sprayer body.
3. Remove LH tire and set aside. Install supplied LH tire (chamfered holes) and secure with supplied inner bud wheel nuts. Tire offset must be as shown in order to maintain 22" or 30" spacing between center of inside tire to center of outside tire.
4. Attach dual spacer and secure with supplied outer bud wheel nuts (flat side towards rim).
5. Attach outer LH tire (removed in step 3) to dual spacer with supplied wheel studs and wheel nuts removed in step 3. Make sure the distance between the center of inside tire to center of outside tire is 22" or 30". Wheels may need to be reversed and exchanged.
6. See "50 hours service - Wheel bolts and nuts" in "Maintenance" section for proper torque and tightening sequence.
7. Repeat the procedure for RH wheels.
8. Retighten bolts and wheel bolts to specified torque after 8 hours of work.
9. Check the distance between the center of inside LH tire to center of inside RH tire. The distance must be 88" for 22" duals, or 60" for 30" duals. If necessary, adjust the track width. See previous section "Altering the track width".



WARNING! Securely support the sprayer during axle adjustments. Never attempt to adjust axles with liquid in the tank. Always block wheels on opposite side when adjusting axles.



ATTENTION! The wheels supplied with the dual tire kits must be used on the inside tires only. The rims have chamfered holes to match the supplied inner bud wheel nuts.

Boom

Safety info

The boom must not be folded/unfolded while driving! Never use the folding/unfolding functions before sprayer has been stopped! Failure to do so will cause damage to the boom.

 **DANGER!** Before unfolding the boom it is important to connect the sprayer to the tractor to prevent overbalancing of the sprayer.

 **DANGER!** When folding or unfolding the boom, make sure that no persons or objects are in the operating area of the boom.

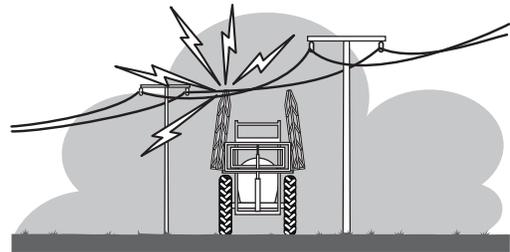
 **DANGER!** Always follow the guidelines listed below when driving in areas with overhead power lines:

Never use the folding/unfolding functions in areas with overhead power lines.

Unintended boom movements can cause contact with overhead power lines.

 **ATTENTION!** A label (ref. no. 10533003) is located on the sprayer's drawbar. This label must be visible to the operator when hooking up the sprayer.

 **ATTENTION!** Only unfold and fold the boom on level ground.

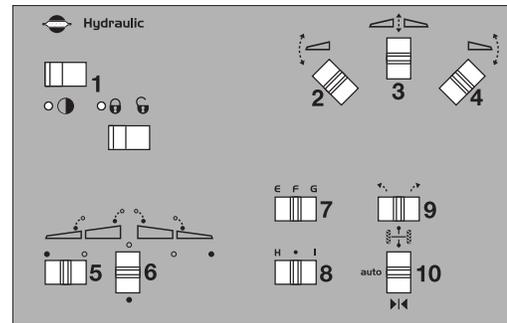


5 - Operation

Maneuvering of the FORCE™ boom

The switches on the hydraulic control box control the following functions:

1. Power ON/OFF
2. Boom tilt left
3. Boom lift raise/lower
4. Boom tilt right
5. Boom outer folding (both sides)
6. Boom inner folding (both sides)
7. Optional function
8. Optional function
9. Manual track control (left/right) (optional)
10. Track control auto (manual/auto/lock) (optional)



To unfold the boom, do the following:

1. Push switch (3) upwards to lift the boom clear of the transport brackets.
2. Push switch (6) downwards to unfold the inner sections. Rear transport hooks disengage automatically.
3. Push switches (2) and (4) downwards to lower individual tilt rams.
4. Push switch (5) to the left to unfold outer sections.
5. Push switch (3) downwards to lower the boom to correct height above crop or ground level.

The folding procedure is the reverse of unfolding.



WARNING! Ensure that the boom is clear from the transport brackets before unfolding.



WARNING! The folding functions (switch 5 and 6) must only be operated when the sprayer is stationary! Failure to do so will damage the boom.



ATTENTION! Boom cannot be operated with tractor's hydraulic levers.

Alternative boom width

It is possible to spray with boom only half unfolded. If this is needed, only unfold inner sections by pressing switch (6) downwards. On the EFC control unit also turn off the spray sections placed on outer boom sections.

Boom support wheels

The boom is equipped with two support wheels. When spraying with low boom heights on bare ground or plants in the first growth stage, it is recommended to fold down the support wheels. In later growth stages the wheels should remain folded up.

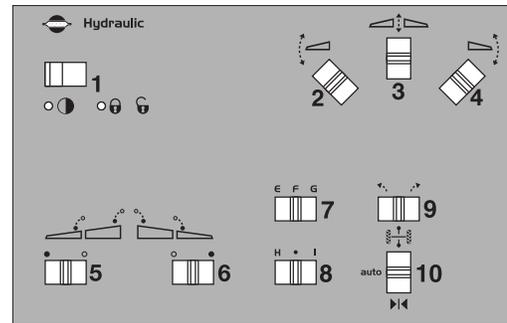


ATTENTION! When driving on public roads the support wheels should be folded up and secured in order to keep the machine overall width according to the regulations!

Maneuvering of the EAGLE™ SPC boom

The switches on the hydraulic control box control the following functions:

1. Power ON/OFF
2. Boom tilt left
3. Boom lift raise/lower
4. Boom tilt right
5. Boom folding (left side)
6. Boom folding (right side)
7. Optional function
8. Optional function
9. Manual track control (left/right) (optional)
10. Track control auto (manual/auto/lock) (optional)



To unfold the boom, do the following:

1. Push switch (3) upwards to lift the boom clear of the transport brackets.
2. Push switches (5) and (6) to the left to unfold the wings. Rear transport hooks disengage automatically.
3. Push switches (2) and (4) downwards to lower individual tilt rams.
4. Push switch (3) downwards to lower the boom to correct height above crop or ground level.

The folding procedure is the reverse of unfolding.



WARNING! Ensure that the boom is clear from the transport brackets before unfolding.



WARNING! The folding functions (switches 5 and 6) must only be operated when the sprayer is stationary! Failure to do so will damage the boom.



ATTENTION! Boom cannot be operated with tractor's hydraulic levers.

Alternative boom width

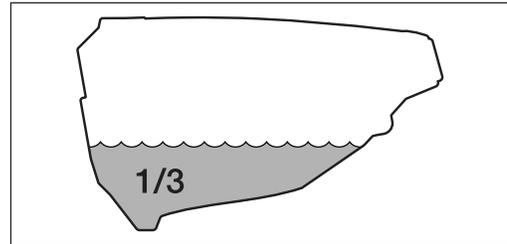
It is possible to spray with only one side folded. If this is needed, first unfold and tilt down the boom completely and then push switch (5) or (6) to the right to fold in the left or right wing only. On the EFC control unit, also turn off the spray sections placed on the folded side.

5 - Operation

LookAhead Liquid system

Filling of water

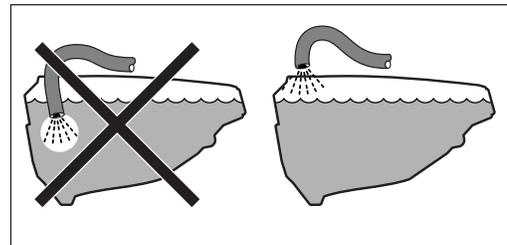
Tank should normally be filled 1/3 with water before adding chemicals. Always follow instructions given on the chemical container!



WARNING! If the sprayer is put aside with liquid in the main tank, all MANIFOLD valves must be closed.

Filling through tank lid

Water is filled into the tank by removing the tank lid located at front of sprayer tank which is accessible from platform. It is recommended to use water as clean as possible for spraying purposes. Always fill water through the strainer basket to prevent foreign particles from entering the tank. An overhead tank can be used in order to obtain high filling capacity.

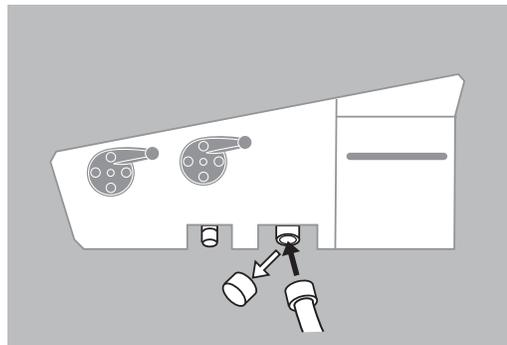


WARNING! Do not let the filling hose enter the tank. Keep it outside the tank, pointing towards the filling hole. If the hose is lowered into the tank and the water pressure drops at the water supply, chemicals may be siphoned back and contaminate the water supply lines and source.

Main Tank Quick Fill (optional equipment)

The Quick Filling Device is operated as follows:

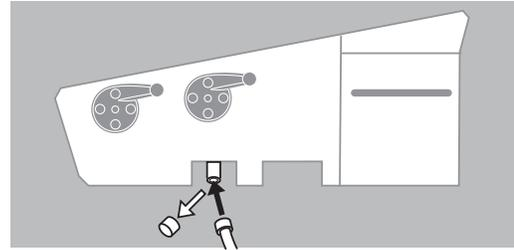
1. Remove plug from Quick Fill valve and connect filling hose from water supply.
2. Open the Quick Fill valve and fill tank to desired level.
3. Keep an eye on the main tank level indicator.
4. Close the Quick Fill valve and remove the filling hose.
5. Replace the plug to the Quick Fill coupler when filling is complete.



Flush Tank Quick Fill

A flush tank is integrated into the rear end of the sprayer and is filled via the quick coupler at the manifold system:

1. Remove plug from Quick Fill valve and connect filling hose from water supply.
2. Open the Quick Fill valve and fill tank to desired level.
3. Keep an eye on the flush tank level indicator located on the platform.
4. Close the Quick Fill valve and remove the filling hose.
5. Replace the plug to the Quick Fill coupler when filling is complete.



Capacity: 120 gal. (450 liters).

Only fill flush tank with clean water! To avoid algae developing in the flush tank, always drain the flush tank if the sprayer is not in use for a longer period of time.

For cleaning purposes etc. the flush tank is also accessible via the tank lid on top of tank.

Filling of clean water tank

A clean water tank is fitted above the MANIFOLD system. It is accessed for filling from the sprayer's left side when entering the platform (see subject "Platform"). Remove tank lid, fill with clean water and reposition tank lid.

For use of water, turn the ball valve lever to open tap. The ball valve is located just below the SafetyLocker on sprayer's left side. The water from this tank is for hand washing, cleaning of clogged nozzles, etc. Only fill the clean water tank with clean water.

Capacity: 6.6 gal. (25 liters).

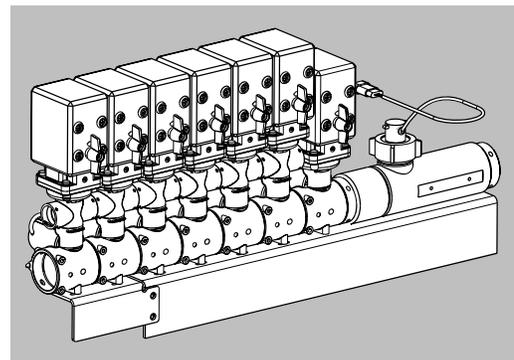


WARNING! Although the clean water tank is only filled with clean water, this water must never be used for drinking.

Adjustment of EFC operating unit

Before spraying, adjust the EFC operating unit using clean water (without chemicals).

1. Choose the correct nozzle for the spray job by turning the TRIPLET nozzle bodies. Make sure that all nozzles are the same type and capacity. See the "Spray Technique" book.
2. On-off switch is activated against spraying position.
3. All section valve switches are activated against spraying position.
4. Pressure regulation switch is activated until emergency handle stops rotating (minimum pressure).
5. Put the tractor in neutral and adjust the P.T.O. and thereby the number of revolutions of the pump corresponding to the intended travelling speed. Remember the number of revolutions on the P.T.O. must be kept between 650-1100 rpm (pump 1000 r/min).
6. Pressure regulation switch is activated until the required pressure is shown on the pressure gauge.



5 - Operation

Safety precautions - crop protection chemicals



Always be careful when working with crop protection chemicals!



WARNING! Always wear correct protective clothing before handling chemicals!

Personal protection

Depending on chemical type, protective gear /equipment should be worn to avoid contact with the chemicals, e.g.:

- Gloves
- Waterproof boots
- Headgear
- Respirator
- Safety goggles
- Chemical resistant overall



WARNING! Protective clothing/equipment should be used when preparing the spray liquid, during the spray job and when cleaning the sprayer. Follow the chemical manufacturer's instructions given on the chemical label.



WARNING! It is always advisable to have clean water available, especially when filling the sprayer with the chemical.



WARNING! Always clean the sprayer carefully and immediately after use.



WARNING! Only mix chemicals in the tank according to directions given by the chemical manufacturer.



WARNING! Always clean the sprayer before changing to another chemical.

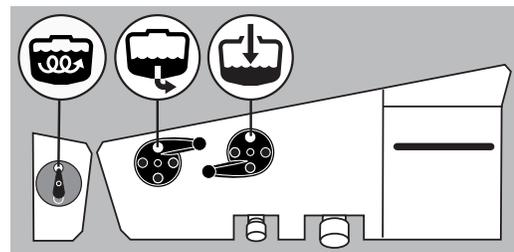
Filling chemicals through tank lid

The chemicals are filled through the tank lid - Note instructions on the chemical container!



WARNING! Be careful not to slip or splash chemicals when carrying chemicals up to the tank lid!

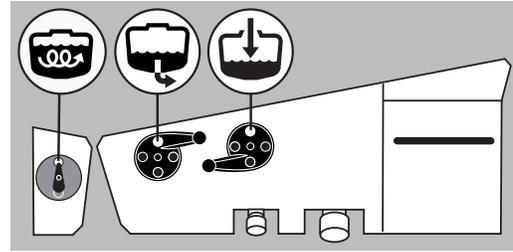
1. Make sure the control unit is switched off.
2. Turn the suction SmartValve handle towards "Suction from main tank". Turn the pressure SmartValve handle towards "Main Tank" and the AgitationValve towards "Agitation".
3. Engage the pump and set P.T.O. revolutions to recommended pump r.p.m.
4. Add the chemicals through the main tank hole.
5. When the spray liquid is well mixed, leave the suction SmartValve handle turned towards "suction from Main tank" and turn pressure SmartValve handle towards "Spraying" position. Keep P.T.O. engaged so the spray liquid is continuously agitated until it has been sprayed on the crop.



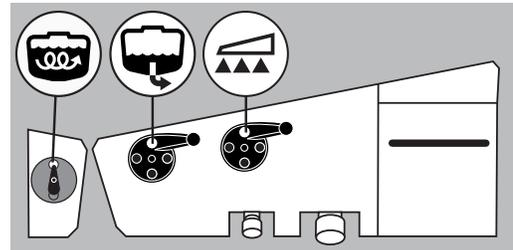
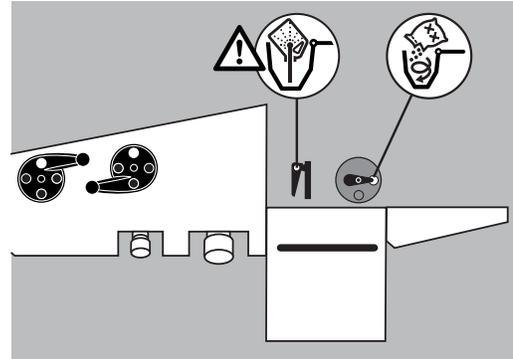
5 - Operation

Filling chemicals by HARDI® ChemFiller

1. Fill the main tank at least 1/3 with water (unless something else is stated on the chemical container label).
2. Turn the handle at the suction SmartValve towards “suction from Main tank”. Turn the pressure SmartValve handle towards “Main tank” and the AgitationValve towards “Agitation”.
3. Engage the pump and set P.T.O. speed at 1000 r/min.
4. Open ChemFiller lid and engage the hopper rinsing device by opening the ChemFiller Vortex nozzle.
5. Measure the correct quantity of chemical and fill it into the hopper. The chemical is transferred to the main tank.
6. When the chemical container is empty, it can be rinsed by the Chemical Container Cleaning device. Place the container over the multi-hole nozzle and press the lever behind the ChemFiller.
7. Close ChemFiller Vortex nozzle when the hopper is rinsed.
8. Close the ChemFiller lid.



9. When the spray liquid is well agitated, turn handle on the pressure SmartValve towards “Spraying” position. Keep P.T.O. engaged so the spray liquid is continuously agitated until it has been sprayed on the crop.



ATTENTION! The scale in the hopper can only be used if the sprayer is parked at level ground! It is recommended to use a measuring jug for best accuracy.



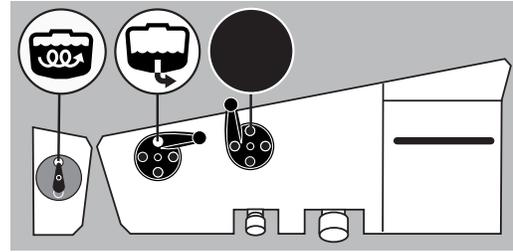
DANGER! Do not press lever unless the multi-hole nozzle is covered by a container to avoid spray liquid hitting the operator.

5 - Operation

Agitation before re-starting spraying

If a spraying job has been interrupted for a while, severe sedimentation can occur depending on chemicals being used. When re-starting spray job it might be necessary to agitate sedimented material first.

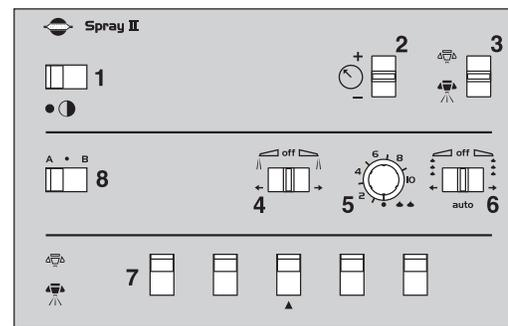
1. Turn handle at the suction SmartValve towards "Suction from main tank". Turn pressure SmartValve towards a "not used" function and turn the Agitation valve towards "Agitation".
2. Engage the pump and set P.T.O. speed at 1000 r/min.
3. Agitation will start and should be continued for at least 10 minutes.
4. Once the chemicals are mixed, spraying can resume. Turn pressure SmartValve towards "Spraying" and start spraying again.



Operating the control unit while spraying

The switches on the spray control box controls the following functions:

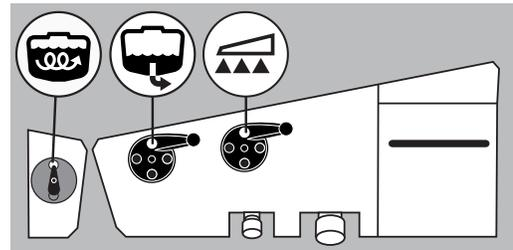
1. Power ON/OFF
2. Spray pressure regulation
3. Main valve ON/OFF
4. End nozzle (Left/OFF/Right)
5. Foam marker blob interval
6. Foam marker (Left/OFF/Right)
7. Section valves
8. Optional function



In order to close the entire boom, switch ON/OFF (3) to OFF position. This returns the pump output to the tank through the return system. The diaphragm Non-drip valves ensure instantaneous closing of all nozzles.

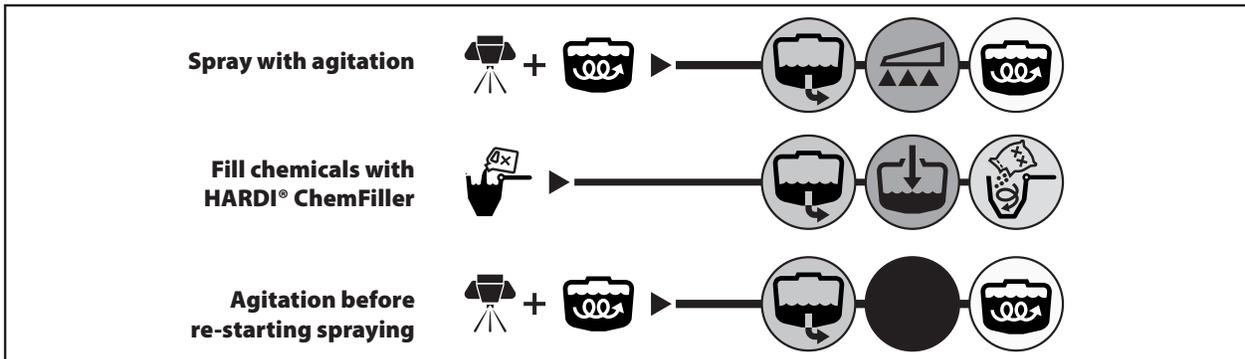
In order to close one or more sections of the boom, switch the relevant distribution valve (7) to off position. The pressure equalization ensures that the pressure does not rise in the sections which are to remain open.

On the sprayer the suction SmartValve should be turned toward "Suction from Main tank" and pressure SmartValve should be turned toward "Spraying". Turn the agitation valve to "Agitation" if necessary.



Quick reference - Operation

In the following diagram, valve positions for different options are described.



5 - Operation

Cleaning

General info

In order to derive full benefit from the sprayer for many years the following service and maintenance program should be followed.



ATTENTION! Always read the individual paragraphs. Read instructions for service/maintenance jobs carefully before starting on the job. If any portion remains unclear or requires facilities which are not available, then for safety reasons please leave the job to your HARDI® dealer's workshop.



ATTENTION!

Clean sprayers are safe sprayers.

Clean sprayers are ready for action.

Clean sprayers cannot be damaged by pesticides and their solvents.

Guidelines

1. Read the whole chemical label. Take note of any particular instructions regarding recommended protective clothing, deactivating agents, etc. Read the detergent and deactivating agent labels. If cleaning procedures are given, follow them closely.
2. Be familiar with local legislation regarding disposal of pesticides washings, mandatory decontamination methods, etc. Contact the appropriate department, e.g. Dept. of Agriculture.
3. Pesticide washings can usually be sprayed out on a soakaway. This is an area of ground that is not used for cropping. You must avoid seepage or runoff of residue into streams, water courses, ditches, wells, springs, etc. The washings from the cleaning area must not enter sewers. Drainage must lead to an approved soakaway.
4. Cleaning starts with the calibration, as a well calibrated sprayer will ensure the minimal amount of remaining spray liquid.
5. It is good practice to clean the sprayer immediately after use and thereby render the sprayer safe and ready for the next pesticide application. This also prolongs the life of the components.
6. It is sometimes necessary to leave spray liquid in the tank for short periods, e.g. overnight, or until the weather becomes suitable for spraying again. Unauthorized persons and animals must not have access to the sprayer under these circumstances.
7. If the product applied is corrosive, it is recommended to coat all metal parts of the sprayer before and after use with a suitable rust inhibitor.

Cleaning and maintenance of filters

Clean filters ensure:

- Sprayer components such as valves, diaphragms and operating unit are not hindered or damaged during operation.
- Nozzle blockages do not occur while spraying.
- Long life of the pump. A blocked suction filter will result in pump cavitation. The main filter protecting sprayer components is the suction filter. Check it regularly.

Use of flush tank and rinsing nozzles

The incorporated flush tank can be used for two different purposes.

A. In-field diluting of remaining spray liquid residue in the spraying circuit for spraying the liquid in the field, before cleaning the sprayer. This cleaning procedure is divided in three main steps:

Cleaning of the liquid system:

1. Empty the sprayer as much as possible. Close AgitationValve (no agitation) and spray until air comes out of all nozzles.
2. Turn Suction SmartValve towards "Flush tank" and pressure SmartValve towards "Main tank".
3. Engage and set the pump at approximately 300 r.p.m.
4. When 1/3 of contents in flush tank are used, turn Suction SmartValve towards "Main tank" and operate all valves on the pressure side of the system in the following order, so all hoses and components are rinsed: Open ChemFiller Vortex nozzle and close it again when clean water comes out of nozzles. Close ChemFiller lid and squeeze the Chemical Container Cleaning handle to clean this device. Open ChemFiller lid again and assure that ChemFiller is empty before spraying main tank contents into field.
5. Leave the suction SmartValve turned towards "Main tank" and open the AgitationValve. Turn the pressure SmartValve towards "Spraying" and spray the remaining liquid in the field you have just sprayed.

Cleaning of Main tank:

6. Turn the suction SmartValve towards "Flush tank" and pressure SmartValve towards "Internal Tank Cleaning".
7. When another 1/6 of contents in flush tank are used, turn suction SmartValve towards "suction from Main tank".
8. Turn pressure SmartValve towards "Spraying" and spray liquid in the field you have just sprayed.
9. Repeat point 6 - 8 one more time.

Outwards cleaning:

10. Turn suction SmartValve towards "Flush tank" and pressure SmartValve towards "Internal Tank Cleaning".
11. When another 1/3 of contents in flush tank are used, turn suction SmartValve towards "Main tank".
12. Turn pressure Agitation valve towards "External Cleaning Device" and wash the sprayer with the cleaning device located on sprayer's right side.
13. Disengage pump again.

B. Flushing the pump, operating unit, spray lines, etc. in case of interruption in spraying before main tank is empty (e.g. beginning rain etc.).

Cleaning of the liquid system:

1. Turn Suction SmartValve towards "Flush tank". (Keep pressure SmartValve in "Spraying"-position).
2. Close AgitationValve (no agitation) and turn CycloneFilter return valve to position A (marked with 1 dot) to prevent return flow from diluting main tank contents.
3. Engage the pump and spray water from flush tank in the field until all nozzle tubes/nozzles are flushed with clean water.
4. Disengage pump again.



ATTENTION! The rinsing nozzles cannot always guarantee a 100% cleaning of the tank. Always clean manually with a brush afterwards, especially if crops sensitive to the chemical just sprayed are going to be sprayed afterwards!



ATTENTION! It is advisable to increase the forward speed (double if possible) and reduce the pressure to 20 psi (1.5 bar) when spraying diluted remaining liquid in the field just sprayed.



ATTENTION! If a cleaning procedure is given on the chemical label, follow it closely.

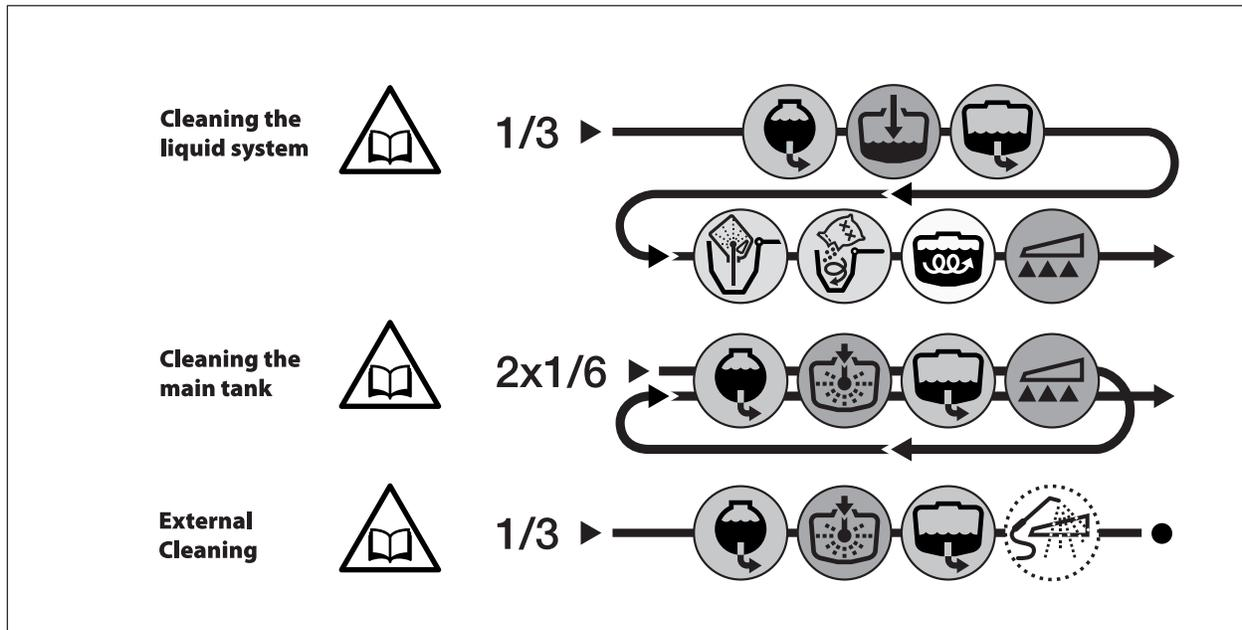


ATTENTION! If the sprayer is cleaned with a high pressure cleaner, lubrication of the entire machine is recommended.

5 - Operation

Quick reference - Cleaning

In the following diagram, valve positions for different options are described.



Technical residue

Inevitably a quantity of spray liquid will remain in the system. It cannot be sprayed properly on the crop, as the pump takes in air when the tank is about to be empty.

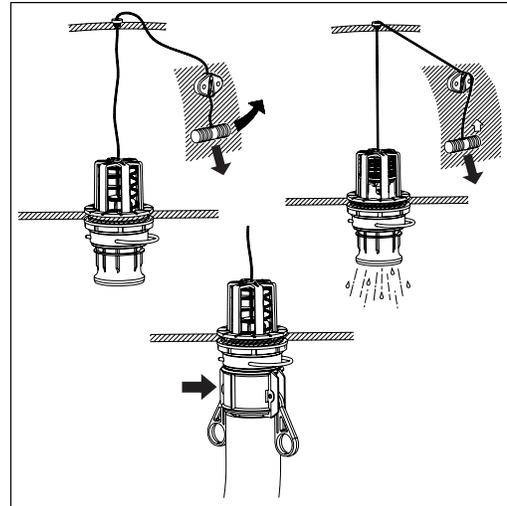
This Technical Residue is defined as the remaining liquid quantity in the system as the first clear pressure drop on the pressure gauge is read.

The residues in the tank should be diluted immediately in the relationship of 1:10 with water and afterwards sprayed to the crop just sprayed with increased driving speed. It is to be noted, however, that the liquid in the lines (with original concentration) will be sprayed out first, so there should be an untreated patch available. In addition, the flush tank is to be used to separately rinse pump, linkage and armature.

Using the drain valve

The drain valve is located and operated from the platform just beside the main tank lid. Pull the string to open the drain valve. The valve is spring-loaded, but can be kept open by pulling the string upwards in the V-shaped slit. To release, pull the string downward and the valve will close automatically.

If draining residues, e.g. liquid fertilizer into a reservoir, a snap-coupler with hose can rapidly be connected to the drain valve and the liquid safely drained.

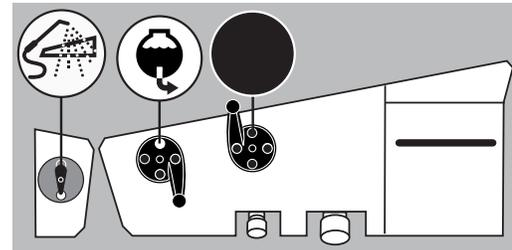


Outside cleaning - Use of External Cleaning Device (optional equipment)

Use the External Cleaning Device to wash everything on the outside of the sprayer. This prevents contamination of storage place, etc. and helps the sprayer last longer.

When the External Cleaning Device is going to be used, open the cover closest to the front, on sprayer's right side. Cleaning gun is located inside the cover.

1. Un-roll the hose from the reel.
2. Engage pump at approximately 300 r.p.m.
3. Turn suction SmartValve towards "Suction from Flush tank" and pressure SmartValve towards not used function.
4. Turn agitation valve towards "External Cleaning Device" and clean sprayer.
5. After cleaning, close the agitation valve again.
6. Roll the hose onto the reel again and close cover.



ATTENTION! If the safety valve is activated, then lower P.T.O. revolutions to avoid rinsing water being lost into main tank.

5 - Operation

Work light selector switch

The boom and work lights selector switch is placed into the SafetyLocker and has three positions:

1. Boom lights ON
2. Lights OFF (neutral position)
3. Work light ON

It is recommended to switch OFF the rear lights of the tractor in order to save power consumption and to avoid reflection.

Spray Technique - see separate book.
Optional extras - see separate books.

Lubrication

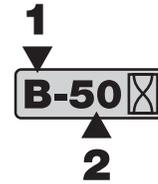
General info

Always store lubricants clean, dry and cool - preferably at a constant temperature - to avoid contamination from dirt and condensed water. Keep oil filling jugs, hoppers and grease guns clean, and clean the lubricating points thoroughly before lubricating. Avoid skin contact with oil products for longer periods.

Always follow the shown direction concerning recommended quantity. If no recommended quantity is given, feed lubricator till new grease becomes visible.

Pictograms in lubrication & oiling plans tell the following:

1. Lubricant to be used (see "Recommended lubricants").
2. Operating hours before next lubrication.



ATTENTION! If the sprayer is cleaned with a high pressure cleaner, lubrication of the entire machine is recommended.

Recommended lubricants



A BALL BEARINGS:
Universal Lithium grease, NLGI No. 2
SHELL RETINAX EP2
CASTROL LMX GREASE



B SLIDE BEARINGS:
Lithium grease with
Molybdenumdisulphide or graphite
SHELL RETINAX HDM2
CASTROL MOLYMAX



C OIL LUB. POINTS:
TOTAL Transmission TM
SAE 80W/90
Castrol EPX 80W/90
SHELL Spirax 80W/90
Mobil Mobilube 80W/90

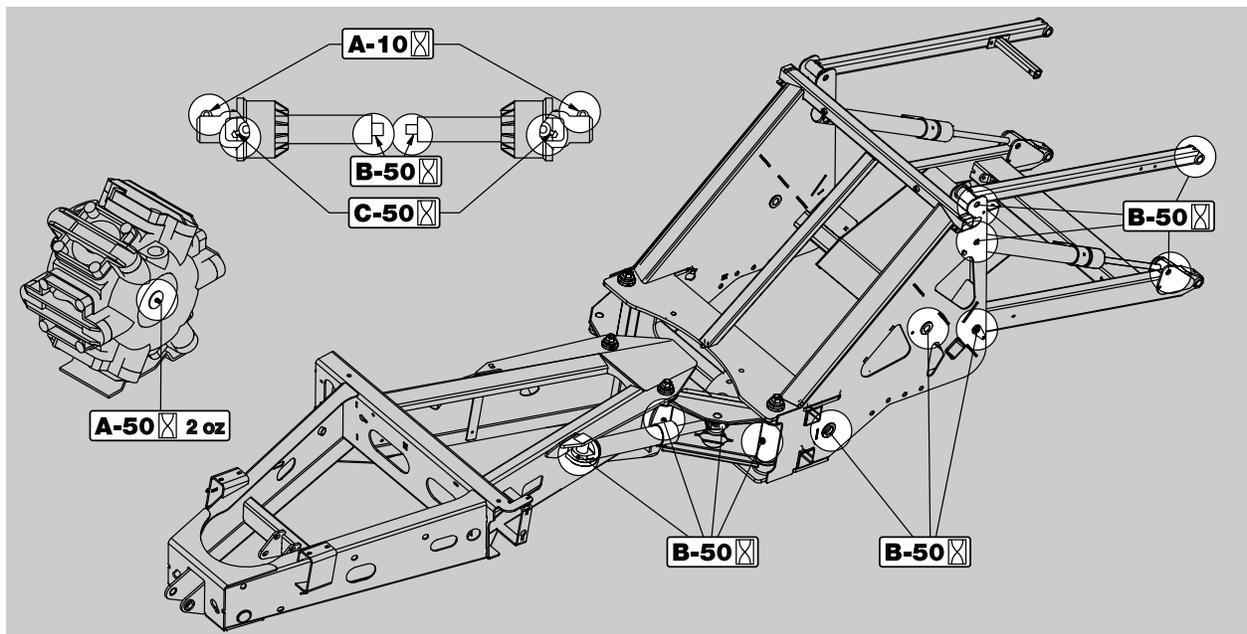


HYDROSTATIC FAN TRANSMISSION:
Hydraulic oil type ISO VG 46,
DIN 51524-2 HLP norms.
SHELL TELLUS T46 (factory use)



GEARBOX:
Transmission oil SAE 80W-90

Trailer lubrication & oiling plan



6 - Maintenance

Service and Maintenance intervals

10 hours service - Cyclone filter

To service the Cyclone filter:

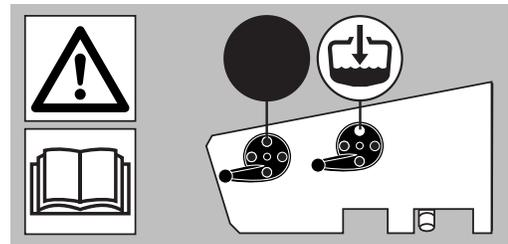
1. Turn suction SmartValve away from "Suction from main tank".
2. Unscrew filter lid (A).
3. Lift the lid and filter (B) from housing.
4. Separate filter from the integrated filter guide in the lid and clean the filter.

To reassemble:

1. Grease the two O-rings on the lid/filterguide. Due to small space at lid for example use a brush to grease with.
2. Mount the filter onto the recess (which may not be greased) in the lid/filterguide.
3. Place the filter/filterlid into housing and screw the lid until it hits the stop.



DANGER! Before opening the Cyclone filter, the Suction SmartValve must always be turned to the unused position and the pressure SmartValve to "Main tank" (both levers pointing forward)! If not, spraying liquid can hit you when opening the filter, and drain from the tank!



10 hours service - EasyClean filter

This filter has a clogging indicator as mentioned in the "Description" chapter, but even if this indicator does not show clogging it should be cleaned every 10 hours.

To service the EasyClean filter:

1. Turn the filter lid counter clockwise to open.
2. Lift out lid and filter from filter housing.
3. Separate filter element from lid/filter guide.
4. Clean filter and if necessary clean the housing for larger impurities.

To reassemble:

1. Grease the O-ring on the filter lid.
2. Press the filter onto filterguide/lid and be sure it has cached the guides.
3. Lift filter/filter lid into housing and be sure it has cached the guides in the bottom of housing.
4. Turn filter lid clockwise to close lid and open bottom valve again.

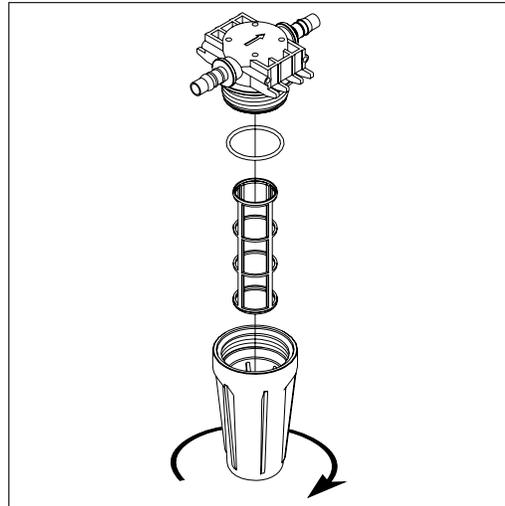


6 - Maintenance

10 hours service - In-Line filter (optional equipment)

If the boom is equipped with In-Line Filters unscrew the filter bowl to inspect and clean the filter. When reassembling the O-ring should be greased.

Alternative filter meshes are available. See section on Technical specifications - Filters and nozzles.



10 hours service - Nozzle filters

Check and clean.



10 hours service - Spraying circuit

Fill with clean water, operate all functions and check for leaks using higher spray pressure than normal. Check nozzle spray patterns visually using clean water.

50 hours service - Transmission shaft

Check function and condition of the transmission shaft protection guard. Replace possible damaged parts.

50 hours service - Wheel bolts and nuts

Tighten wheel bolts and nuts as follows with following torque wrench settings:

Wheel hub to rim plate: 250 Ft/lb (340 Nm)

Tightening sequence: See illustration and tighten in order of numbering.



6 - Maintenance

50 hours service - Tire pressure

Check the tire pressure according to the table in "Technical specifications".



DANGER! Never inflate tires more than to the pressure specified in the table. Over-inflated tires can explode and cause severe personal injuries! See the part "Occasional maintenance - Change of tire".

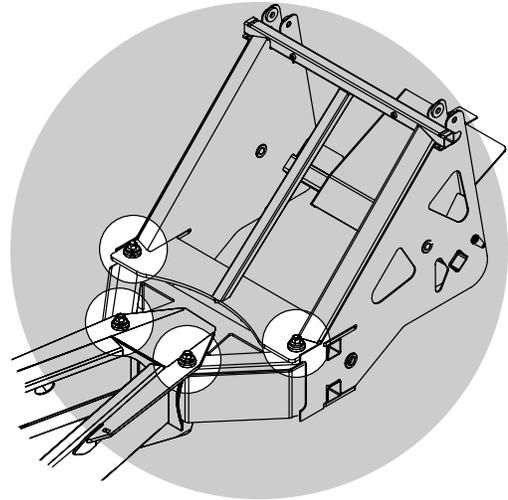


WARNING! If changing tires, always use tires with min. load index as specified.

100 hours service - Check/tighten steering

If too much play is found in the steering section, it must be re-tightened. This applies to both steering and non-steering versions. Re-tighten the nuts on both sides to the specified torque. Specified torque is 184 Ft/lb (250 Nm).

Be sure that the split pin is fitted (or re-fitted if dismantled) at the end of the big bolts.



250 hours service - Readjustment of the boom

See boom Operator's manual.

250 hours service - Hydraulic circuit

Check the hydraulic circuit for leaks and repair if any.



WARNING! Hoses for boom lifting device must be changed after every 5 years of use.

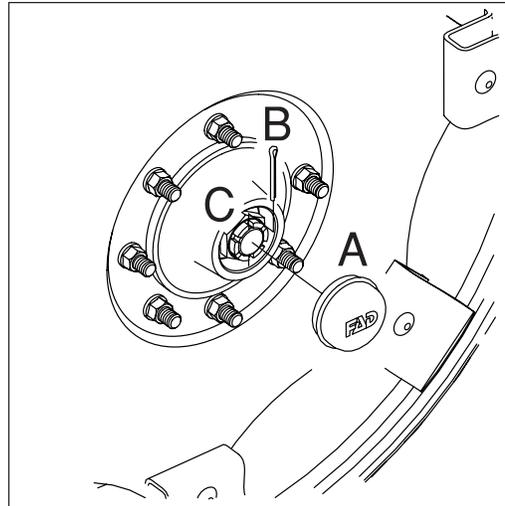
250 hours service - Hoses and tubes

Check all hoses and tubes for possible damages and proper attachment. Replace damaged hoses or tubes.

250 hours service - Wheel bearings

Check for play in the wheel bearings:

1. Place stop wedges in front of and behind LH wheel and jack up RH wheel.
2. Rock the RH wheel to discover possible play in the bearings.
3. If any play, support the wheel axle to prevent the trailer from falling down from the jack.
4. Remove hub cap (A) and cotter pin (B). Turn the wheel and tighten the castle nut (C) until a slight resistance in the wheel rotation is felt.
5. Loosen the castle nut until the first notch (horizontal or vertical) is aligned with the cotter pin hole in the shaft.
6. Fit a new cotter pin and bend it.
7. Fill the hub cap with fresh grease and re-attach it onto the hub.
8. Repeat the procedure on LH wheel.



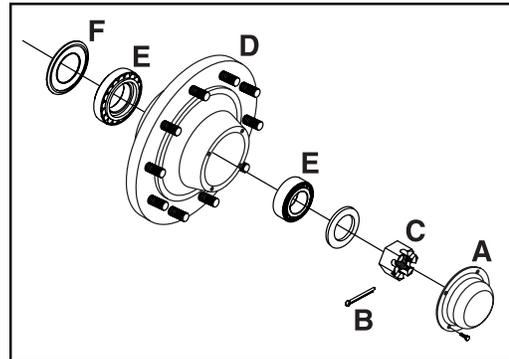
1000 hours service - Transmission shaft

Change the protection tube nylon bearings as described under "Shield replacement on transmission shaft".

1000 hours service - Wheel bearings

Check the condition of the bearings in the following way:

1. Place stop wedges in front of and behind LH wheel and jack up RH wheel.
2. Support the trailer with axle stands.
3. Remove the wheel.
4. Unscrew the 4 Allen bolts and remove the hub cap (A), cotter pin (B) and castle nut (C).
5. Pull off the wheel hub assembly (D). Use a wheel puller if necessary.
6. Remove roller bearings (E), clean all parts in degreasing detergent and dry them. Inspect bearings (E) and replace if necessary.
7. Pack bearings (E) with fresh wheel bearing grease and re-install using a new seal (F).
8. Turn the wheel and tighten the castle nut (C) until a slight resistance in the wheel rotation is felt.
9. Loosen the castle nut until the first notch (horizontal or vertical) is aligned with the cotter pin hole on the shaft.
10. Fit a new cotter pin and bend it.
11. Fill the hub cap with fresh grease and re-attach it onto the hub.
12. Repeat the procedure on the LH wheel.



ATTENTION! The shaft has a vertical and an horizontal cotter pin hole. Use the one first aligned with the notch when loosening the castellated nut.



WARNING! If you do not feel totally confident changing wheel bearings, contact your HARDI® dealers workshop.

6 - Maintenance

Occasional maintenance

General info

The maintenance and replacement intervals for the following will depend very much on the conditions under which the sprayer will be operated and are therefore impossible to specify.

Pump valves and diaphragms replacement

Model 463 pumps:

Diaphragm pump overhaul kit (valves, seals, diaphragms etc.) can be ordered. Detect whether the pump is a 463 model - kit can be ordered at following HARDI® part No.:

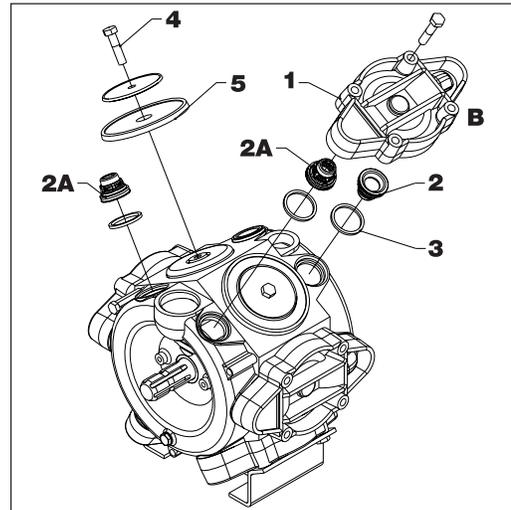
Model 463: part No. 750343

Valves

Remove valve cover (1) before changing the valves (2) - note their orientation so they are replaced correctly!



ATTENTION! A special valve with white flap (2A) is used at the two upperside inlets. It has to be placed in the valve openings as shown. All others are the type with black flap. It is recommended to use new gaskets (3) when changing or checking the valves.



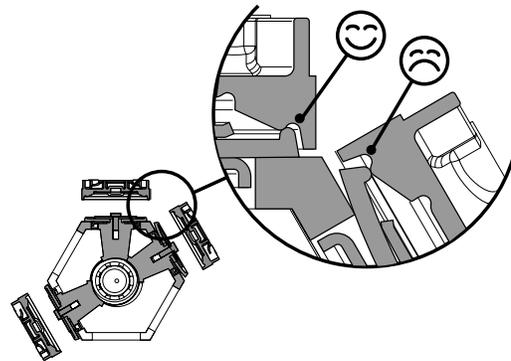
Diaphragms

Remove the diaphragm cover (4). The diaphragm (5) may then be changed. If fluids have reached the crankcase, re-grease the pump thoroughly. Also check that the drain hole at the bottom of the pump is not blocked. Reassemble with the following torque setting.

Reassemble pump model 363/463 with the following torque setting.

Diaphragm cover: 67 Ft/lb (90 Nm)

Diaphragm bolt: 67 Ft/lb (90 Nm)



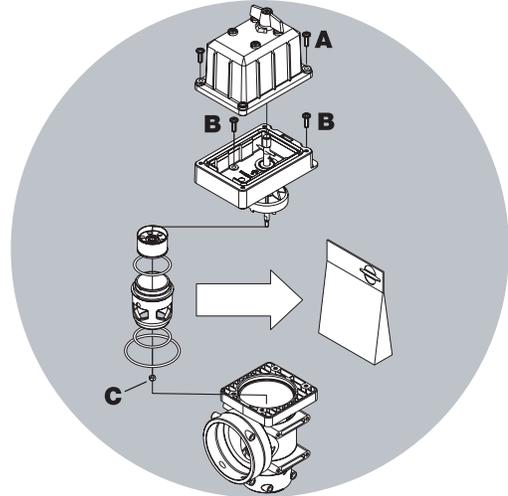
ATTENTION! Before tightening the 4 bolts for the diaphragm cover (B) the diaphragm must be positioned between center and top to ensure correct sealing between diaphragm pumphousing and diaphragm cover. Turn crank shaft if necessary.

6 - Maintenance

Cone check/replacement for EFC operating unit

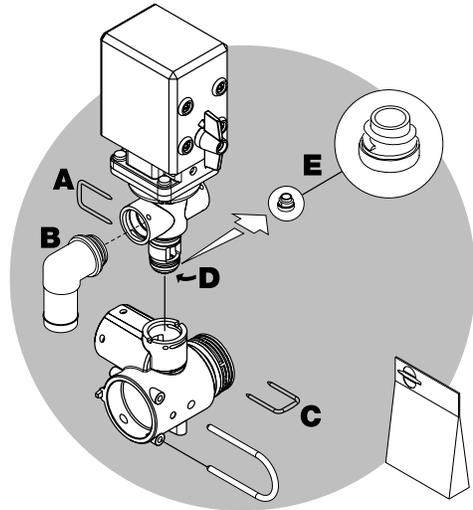
If it becomes difficult to build up sufficient pressure or if pressure fluctuations occur, it may be necessary to replace cone and cylinder. A spare parts kit can be ordered - contact your local dealer to service the unit.

1. Remove 4 x screws (A) and remove the housing.
2. Remove 4 x screws (B) and remove cone.
3. Loosen nut (C) in bottom of the cone.
4. Replace with parts from spare parts kit.
5. Reassemble in reverse order.



Cone check/replacement for EFC distribution valve

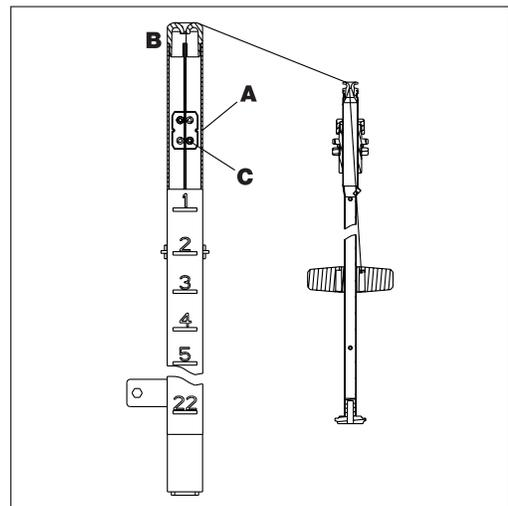
Periodically check the distribution valves for proper sealing. Do this by running the sprayer with clean water and open all distribution valves. Cautiously remove the clip (A) and pull out the hose (B) for the return line. When the housing is drained, there should be no liquid flow through the return line. If there is any leakage, the valve cone (E) must be changed. Remove the clip (C) and lift the motor housing off the valve housing. Then unscrew the screw (D) and replace the valve cone (E). Reassemble in reverse order.



Level indicator adjustment

The level indicator reading should be checked regularly. When the tank is empty, the float should lie on the stop pin, of the rod, and the O-ring on the indicator should be positioned at the top position line (A).

If any deviation is found, pull out the plug (B), loosen screws (C), and adjust the length of the cord.



6 - Maintenance

Level indicator cord replacement

If the cord on the level indicator has to be changed, the float guide pole is removed:

1. Remove the tank drain valve (see paragraph "Drain valve seal replacement") and loosen the fitting holding the pole in position.
2. Pull the pole down through the drain valve hole till it is free in the top of the tank.
3. The pole can now be taken out of the tank through the filling hole.



DANGER! Do not enter the inside of the tank - the parts can be changed from the outside of the tank!

Drain valve seal replacement

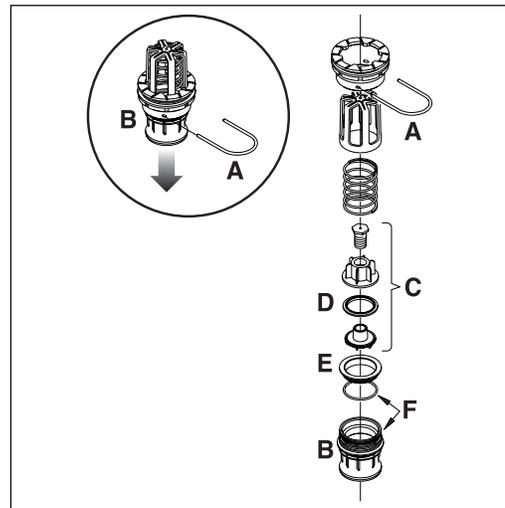
If the main tank drain valve leaks, the seal and seat can be changed the following way.



DANGER! Do not enter the inside of the tank - the parts can be changed from the outside of the tank!



WARNING! Use eye / face protection mask when dismantling the tank drain valve!



1. Make sure the tank is empty and clean.
2. The valve must be closed and the string loose.
3. Pull out the clip (A) and pull down connecting piece (B). The entire valve assembly can now be pulled out.
4. Check cord and valve flap assembly (C) for wear, replace seal (D) and assemble again.
5. Assemble the valve assembly again using a new valve seat (E). Lubricate O-rings (F) before assembly.
6. Fit clip (A) again.

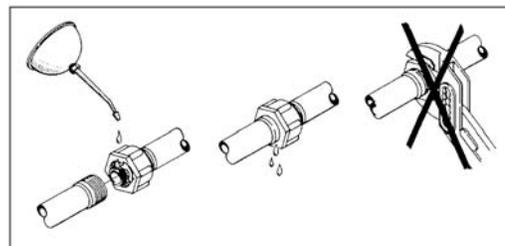


ATTENTION! Check function of valve with clean water before filling chemicals into the tank.

Nozzle tubes and fittings

Poor seals are usually caused by:

- Missing O-rings or gaskets
- Damaged or incorrectly seated O-rings
- Dry or deformed O-rings or gaskets
- Foreign bodies



6 - Maintenance

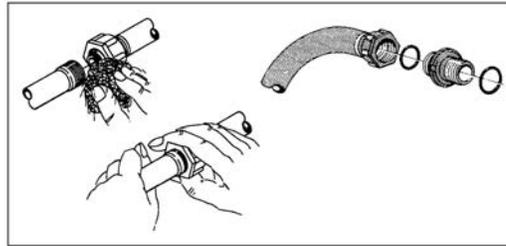
In case of leaks:

DO NOT overtighten. Disassemble, check condition and position of O-ring or gasket. Clean, lubricate and reassemble.

The O-ring must be lubricated ALL THE WAY ROUND before fitting on to the nozzle tube. Use non-mineral lubricant.

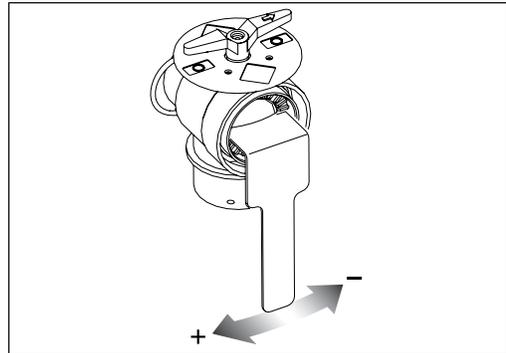
For AXIAL connections, a little mechanical leverage may be used.

For RADIAL connections only hand-tighten them.



Adjustment of 3-way-valve

The MANIFOLD valve can be adjusted if it is too tight to operate - or if it is too loose (=liquid leakage). Correct setting is when the valve can be operated smoothly by one hand. Use a suitable tool and adjust the toothed ring inside the valve as shown on the drawing.



Readjustment boom - general info

Before beginning boom adjustments, please go through this check list:

1. The sprayer must be well lubricated (see part about lubrication).
2. Connect the sprayer to the tractor.
3. Place tractor and sprayer on level ground (horizontal).
4. Unfold boom.
5. Set tilt angle of both wings to horizontal position.

Adjustment of hydraulic cylinders are done without pressure in the system.



ATTENTION! See your Boom Operator's manual supplied with your sprayer for detailed technical information and service procedures specific to your boom configuration.



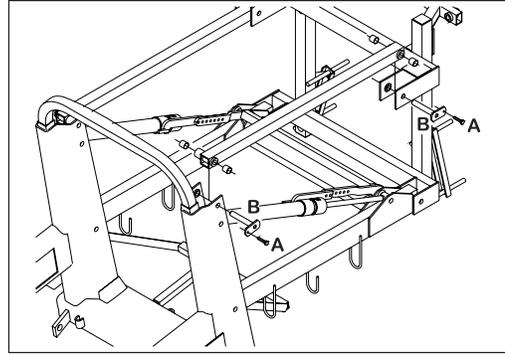
WARNING! Nobody is allowed to be under the boom while adjustment is carried out. Never walk under the boom unless it is safely folded and stowed on the transport brackets.

6 - Maintenance

Wear bushing replacement on boom lift

Inspect the wear bushings and replace before they are worn through.

1. Connect the trailer to a tractor and unfold the booms to working position.
2. Lift the boom center frame with a lifting device and support it until the load is taken off the parallelogram arms.
3. Remove the screws (A), and pull out the pins (B) at one of the upper parallelogram arms and replace the wear bushings.
4. Refit the arm.
5. Repeat this on the other upper arm.
6. The lower arms must be disconnected simultaneously.
7. Grease all grease nipples.
8. Remove the lifting gear.



Change of bulbs

1. Switch off the light.
2. Loosen the screws on the lamp and remove the cover or lens.
3. Remove the bulb.
4. Fit a new bulb, refit the cover and tighten the screws.



ATTENTION! If halogen bulbs are used, never touch the bulb with the fingers. Natural moisture in the skin will cause the bulb to burn out when the light is switched on. Always use a clean cloth or tissue when handling halogen bulbs.

Wear bushing replacement on steering

If too much play is found in the steering, the wear bushings must be replaced. This should be done at your local HARDI® dealer.

Shock absorbers

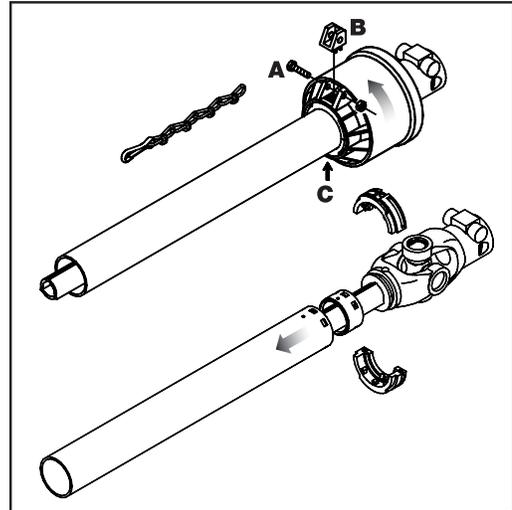
If the shock absorbers lose their efficiency or start leaking oil, they should be replaced.

Shield replacement on transmission shaft

1. Remove bolt (A), lock (B) and grease nipple (C). Twist uni CV-joint cover 1/4 turn and pull it backwards.
2. Remove the synthetic bearings and protection tube.
 - 2a. Remove inner bushing from protection tube.
3. Assemble again in reverse order, using new parts where necessary. Remember to fit chains again.
4. Grease bearings.
5. Repeat procedure to the opposite part of the transmission shaft.

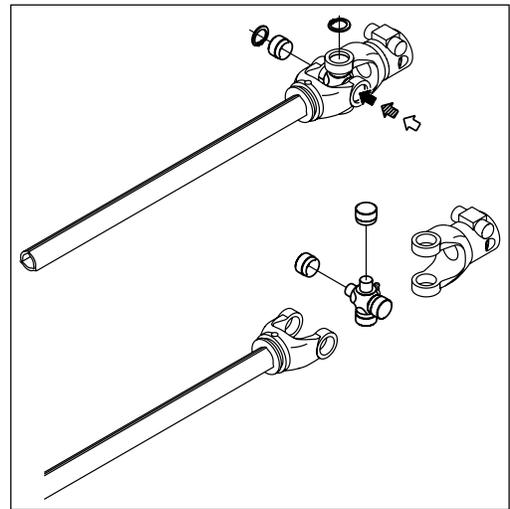


ATTENTION! Only use genuine HARDI® spare parts to service the transmission shaft.



Replacement of transmission shaft cross journals.

1. Remove protection guard as described previously.
2. Remove Seeger circlip rings.
3. Press the cross journal sideways - use hammer and mandrel if necessary.
4. Remove needle bearing cups and cross journal can now be removed.
5. Carefully remove needle bearing cups from new cross journal and install it in reverse order. Before fitting the needle bearing cups again, check that needles are placed correctly. Avoid dust and dirt in the new bearings.
6. Repeat procedure to the opposite part of the transmission shaft.



6 - Maintenance

Change of tire

Should it be necessary to replace tires, it is recommended to leave this to a specialist and follow the mentioned rules.

1. Always clean and inspect the rim before mounting.
2. Always check that the rim diameter corresponds exactly to the rim diameter molded on the tire.
3. Always inspect inside of the tire for cuts, penetrating objects or other damages. Repairable damages should be repaired before installing the tube. tires with unrepairable damages must never be used.
4. Also inspect inside of the tire for dirt or foreign bodies and remove it before installing the tube.
5. Always use tubes of recommended size and in good condition. When fitting new tires always fit new tubes.
6. Before mounting, always lubricate both tire beads and rim flange with approved lubricating agent or equivalent anti-corrosion lubricant. Never use petroleum based greases and oils because they may damage the tire. Using the appropriate lubricant the tire will never slip on the rim.
7. Always use specialized tools as recommended by the tire supplier for mounting the tires.
8. Make sure that the tire is centered and the beads are perfectly seated on the rim. Otherwise danger of bead wire tear can occur.
9. Inflate the tire to 14.5-19 p.s.i. (100-130 kPa) then check whether both beds are seated perfectly on the rim. If any of the beads do not seat correctly, deflate the assembly and re-center the beads before starting inflation of the tire. If the beads are seated correctly on the rim at 14.5-19 p.s.i. (100-130 kPa), inflate the tire to a maximum of 36 p.s.i. (250 kPa) until they seat perfectly on the rim.
10. Never exceed the maximum mounting pressure molded on the tire!
11. After mounting tires, adjust inflation pressure to operation pressure recommended by the tire manufacturer.
12. Do not use tubes in tubeless tires.



DANGER! Non observance of mounting instructions will result in the bad seating of the tire on the rim and could cause the tire to burst leading to serious injury or death!



DANGER! Never mount or use damaged tires or rims! Use of damaged, ruptured, distorted, welded or brazed rim is not allowed!

Off-season storage

Off-season storage program

When the spraying season is over, you should devote some extra time to the sprayer. If chemical residue is left over in the sprayer for longer periods, it can reduce the life of the individual components. To preserve the sprayer and to protect the components, carry out following off-season storage program.

1. Clean the sprayer completely - inside and outside - as described under "Cleaning of the sprayer". Make sure that all valves, hoses and auxiliary equipment have been cleaned with detergent and flushed with clean water afterwards, so no chemical residue is left in the sprayer.
2. Replace possible damaged seals and repair possible leaks.
3. Empty the sprayer completely and let the pump work for a few minutes. Operate all valves and handles to drain as much water from the spraying circuit as possible. Let the pump run until air is coming out of all nozzles. Remember to drain the flush tank also.
4. Pour appr. 13 gal (50 liters) anti-freeze mixture consisting of 1/3 automotive anti-freeze and 2/3 water into the tank.
5. Engage the pump and operate all valves and functions on the MANIFOLD, operating unit, chemical inductor etc. allowing the anti-freeze mixture to be distributed around the entire circuit. Open the operating unit main on/off valve and distribution valves so the anti-freeze is sprayed through the nozzles as well. The anti-freeze will also prevent O-rings, seals, diaphragms etc. from drying out.
6. Lubricate all lubricating points according to the lubricating scheme - regardless of intervals stated.
7. When the sprayer is dry, remove rust from possible scratches or damages in the paint and touch up the paint.
8. Remove the glycerine-filled pressure gauges and store them frost free in vertical position.
9. Apply a thin layer of anti-corrosion oil (e.g. SHELL ENSIS FLUID, CASTROL RUSTILLO or similar) on all metal parts. Avoid oil on rubber parts, hoses and tires.
10. Fold the boom in transport position and relieve pressure from all hydraulic functions.
11. Store all electric plugs and sockets in a dry plastic bag to protect them against moisture, dirt and corrosion.
12. Remove the control boxes and computer display from the tractor, and store them dry and clean (in-house).
13. Wipe hydraulic snap-couplers clean and fit the dust caps.
14. Apply grease on all hydraulic ram piston rods which are not fully retracted in the barrel to protect against corrosion.
15. Chock up the wheels, to prevent moisture damage and deformation of the tires. Tire blacking can be applied to the tire walls to preserve the rubber.
16. To protect against dust, the sprayer can be covered by a tarpaulin. Ensure ventilation to prevent condensation.

Preparing the sprayer for use after storage

After a storage period, the sprayer should be prepared for the next season in the following way:

1. Remove the cover.
2. Remove the support from the wheel axle and adjust the tire pressure.
3. Wipe off the grease from hydraulic ram piston rods.
4. Fit the pressure gauges again. Seal with Teflon tape.
5. Connect the sprayer to the tractor including hydraulics and electric's.
6. Check all hydraulic and electric functions.
7. Empty the tank of remaining anti-freeze.
8. Rinse the entire liquid circuit on the sprayer with clean water.
9. Fill with clean water and check all functions.

6 - Maintenance

Operational problems

General info

In cases where breakdowns have occurred, the same factors always seem to come into play:

1. Minor leaks on the suction side of the pump will reduce the pump capacity or stop the suction completely.
2. A clogged suction filter will hinder or prevent suction so that the pump does not operate satisfactorily.
3. Clogged up pressure filters will result in increasing pressure at the pressure gauge but lower pressure at the nozzles.
4. Foreign bodies stuck in the pump valves with the result that these cannot close tightly against the valve seat. This reduces pump efficiency.
5. Poorly reassembled pumps, especially diaphragm covers, will allow the pump to suck air resulting in reduced or no capacity.
6. Hydraulic components that are contaminated with dirt result in rapid wear to the hydraulic system.

Therefore ALWAYS check:

1. Suction, pressure and nozzle filters are clean.
2. Hoses for leaks and cracks, paying particular attention to suction hoses.
3. Gaskets and O-rings are present and in good condition.
4. Pressure gauge is in good working order. Correct dosage depends on it.
5. Operating unit functions properly. Use clean water to check.
6. Hydraulic components are maintained clean.

7 - Fault finding

Liquid system

FAULT	PROBABLE CAUSE	CONTROL/REMEDY
No spray from boom when turned on.	Air leak on suction line.	Check if suction filter O-ring is sealing. Check suction tube and fittings. Check tightness of pump diaphragm and valve covers.
	Air in system.	Fill suction hose with water for initial prime.
	Suction/pressure filters clogged.	Clean filters. Check yellow suction pipe is not obstructed or placed too near the tank bottom.
Lack of pressure.	Incorrect assembly.	Boost valve is open. Safety valve spring for Self-cleaning filter not tight. Too little distance between yellow suction pipe and tank bottom.
	Pump valves blocked or worn.	Check for obstructions and wear.
	Defective pressure gauge.	Check for dirt at inlet of gauge.
Pressure dropping.	Filters clogging.	Clean all filters. Fill with cleaner water. If using powders, make sure agitation is on.
	Nozzles worn.	Check flow rate and replace nozzles if it exceeds 10%.
	Tank is air tight.	Check vent in tank lid is clear.
	Sucking air towards end of tank load.	Lower pump r.p.m.
Pressure increasing.	Pressure filters beginning to clog.	Clean all filters.
Formation of foam.	Air is being sucked into system.	Check tightness/gaskets/O-rings of all fittings on suction side.
	Excessive liquid agitation.	Reduce pump r.p.m. Check safety valve is tight. Ensure returns inside tank are present. Use foam damping additive.
Liquid leaks from bottom of pump.	Damaged diaphragm.	Replace. See "Pump valves and diaphragms replacement".
Operating unit not functioning.	Blown fuse(s).	Check mechanical function of microswitches. Use cleaning/lubricating agent if the switch does not operate freely. Check motor. 450-500 milli-Amperes max. Change motor, if over.
	Wrong polarity.	Brown - pos. (+). Blue - neg. (-).
	Valves not closing properly.	Check valve seals for obstructions. Check microswitch plate position. Loosen screws holding plate by 1/2 turn.
	No power.	Wrong polarity. Check that brown is pos. (+), Blue is neg. (-). Check print plate for dry solders or loose connections. Check fuse holder is tight around fuse.

7 - Fault finding

Hydraulic system - Z model

FAULT	PROBABLE CAUSE	CONTROL/REMEDY
No boom movements when activated.	Insufficient hydraulic pressure.	Check oil pressure - min. 1900 psi (130 bar), max. 2300 psi (160 bar). Check tractor hydraulic oil level.
	Insufficient oil supply.	Oil flow must be min. 2.6 gpm (10 l/min.) max. 23.8 gpm (90 l/min.). Check tractor hydraulic oil level.
	Blown fuse(s).	Check / replace fuse in junction box.
	Bad / corroded electrical connections.	Check / clean connections, multi plugs etc.
	Insufficient power supply.	Voltage on activated solenoid valve must be more than 8 Volts. Use wires at least 10 awg. (4.0 mm ²) for power supply.
	Defective relay / diodes in junction box.	Check relays, diodes and soldering at PCB in junction box.
	Clogged restrictors a or b in by-pass block.	Remove and clean restrictors a and b in bypass block (See hydraulic diagram) Change hydraulic oil + filter.
Wrong polarity.	Check polarity. White pos. (+) Blue neg. (-).	
Boom lift raises to max. pos. when tractor hydraulics are engaged.	Wrong oil inlet to by-pass block.	Connect hydraulic snap couplers opposite in tractor outlets, or engage spool valve lever in opposite direction.
	Back pressure in return line exceeds 290 psi (20 bar).	Connect the return line with free flow to hydraulic oil reservoir. Divide return line in two and lead return oil back to reservoir via two spool valves.
Oil heats up in Closed Center systems.	By-pass valve 0 does not close properly.	Check / close (screw in) by-pass valve 0.
	Internal leaks in flow regulator.	Replace flow regulator O-rings and back-up rings. Replace flow regulator.
Individual ram does not move.	Clogged restrictor.	Dismantle and clean restrictor.

7 - Fault finding

Mechanical problems

Emergency operation - Liquid system

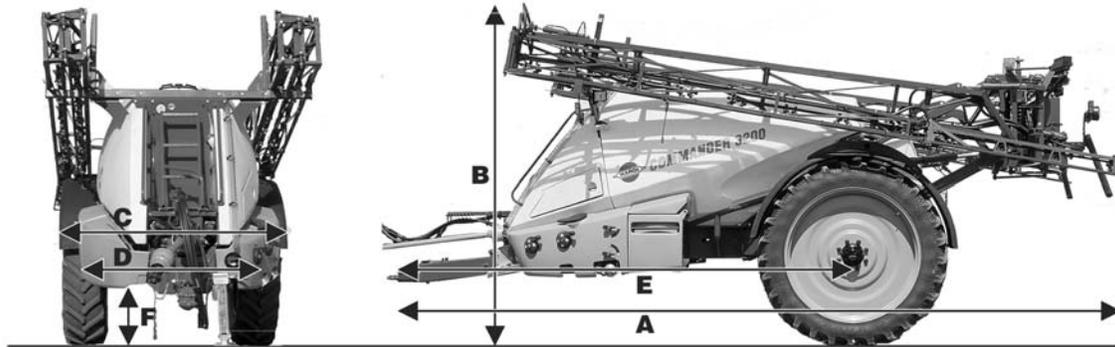
In case of power failure it is possible to operate all functions of the operating unit manually. First disconnect the multi plug from the control box. Now manually turn the emergency control knobs.

The problem may be due to a blown fuse. A fuse is placed inside the box. Fuse type: Thermo

8 - Technical specifications

Dimensions

Overall dimensions



	A	B	C1*	C2**	D	E	F
4400	25' 0"	11' 10"	11' 9"	11' 6"	60" to 88"	16' 11"	31"
6600	25' 7"	11' 10"	11' 9"	11' 6"	60" to 88"	17' 5"	31"

*EAGLE™ SPC boom

**FORCE™ boom

All measurements are in feet and inches.

Weight

	4400*	4400**	6600*	6600**
Weight at drawbar:	1,650 lbs (750 kg)	4,920 lbs (2,230 kg)	2,230 lbs (1,010 kg)	6,920 lbs (3,140 kg)
Weight on axle:	7,940 lbs (3,600 kg)	15,480 lbs (7,020 kg)	9,720 lbs (4,410 kg)	20,680 lbs (9,380 kg)
Weight total:	9,590 lbs (4,350 kg)	20,390 lbs (9,250 kg)	11,950 lbs (5,420 kg)	27,600 lbs (12,520 kg)

*Weights with empty tank

**Weights with full tank

Wheel and axle dimensions

Wheel	Adj. axle	Fixed axle	Duals 22" row	Duals 30" row	Clearance*
320/90 R46	60" - 88"	120"	88"/132"	60"/90"	29-1/2"
320/90 R50	60" - 88"	120"	88"/132"	60"/90"	31-1/2"

*under axle

8 - Technical specifications

Specifications

Diaphragm pumps

Pump model 463/6.5	PSI	RPM	GPM	HP
	0	1000	91.9	4.3
	29	1000	84.8	5.4
	58	1000	82.7	6.8
	88	1000	81.4	8.3
	147	1000	78.2	11.0
	220	1000	75.5	13.8

Filters and nozzles

Filter gauze width

30 mesh: 0.58 mm

50 mesh: 0.30 mm

80 mesh: 0.18 mm

100 mesh: 0.15 mm

Temperature and pressure ranges

Operating temperature range: 36°F to 104°F (2° to 40° C.)

Operating pressure for safety valve: 220 psi (15 bar)

Max. pressure on the pressure manifold: 290 psi (20 bar)

Max. pressure on the suction manifold: 100 psi (7 bar)

Power consumption

Recommended tractor engine power output are as follows:

Sprayer	Hp	kW
4400	115	86
6600	150	110

Tire pressure

Tire size	Rec. inflation pressure in p.s.i. (bar)
-----------	---

320/90 R46	35 (2.4)
------------	----------

320/90 R50	35 (2.4)
------------	----------



DANGER! Never inflate tires more than to the pressure specified in the table. Over-inflated tires can explode and cause severe personal injuries! See the part "Occasional maintenance - Change of tire".

Materials and recycling

Disposal of the sprayer

When the equipment has completed its working life, it must be thoroughly cleaned. The tank, hose and synthetic fittings can be incinerated at an authorized disposal plant. The metallic parts can be scrapped. Always follow local legislation regarding disposal.

Materials used:

Tank: HDPE

Hoses: PVC

Valves: mainly glass-filled PA.

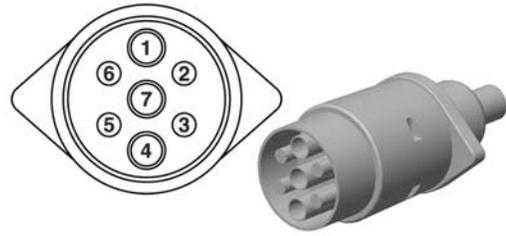
Fittings: PA

Electrical connections

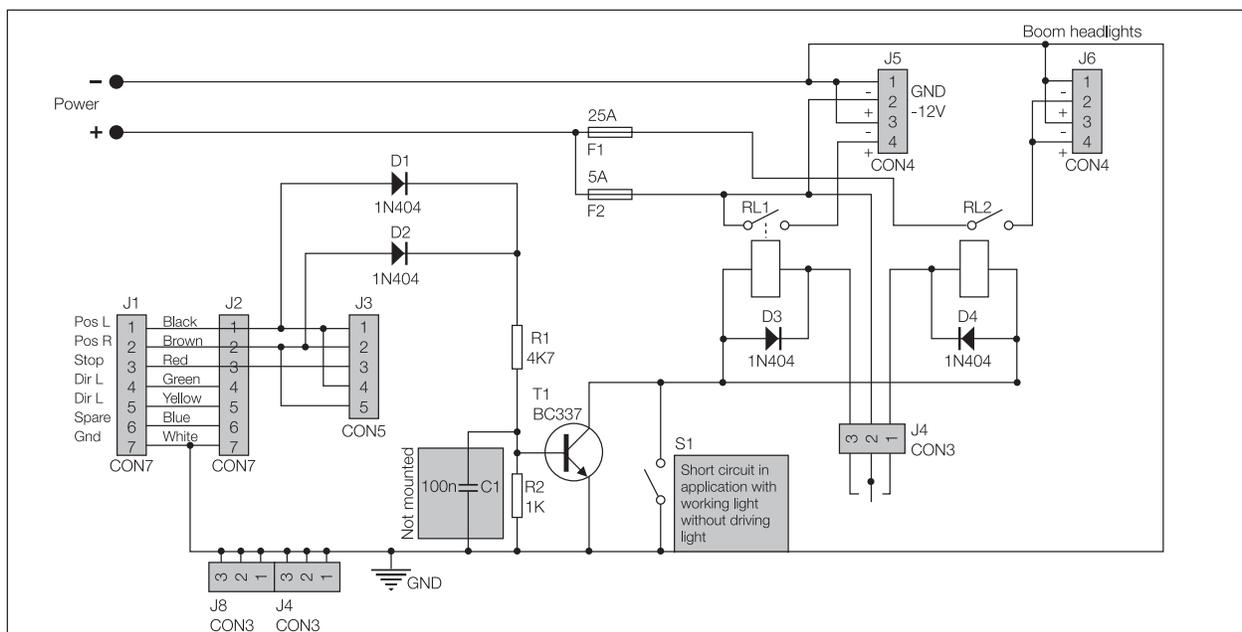
Rear lights

The wiring is in accordance with ISO 1724.

Position	Wire color
1. LH direction indicator	Yellow
2. Free	Blue
3. Frame	White
4. RH direction indicator	Green
5. RH rear position lamp	Brown
6. Stop lamps	Red
7. LH rear position lamp	Black



Electrical specifications for boom and work light

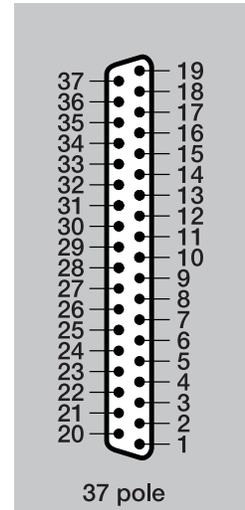
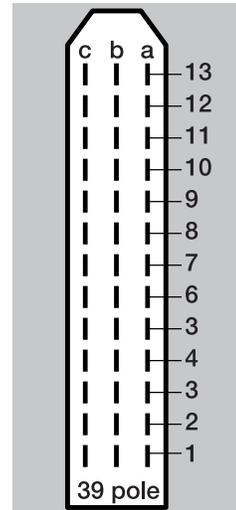


8 - Technical specifications

Electrical connections for SPRAY II

39 or 37 poled plug with cable.

39-pole	37-pole	SPRAY II
1a	5	S1+
1b	6	S1-
1c	26	End nozzle L
2a	7	S2+
2b	8	S2-
2c	25	End nozzle R
3a	9	S3+
3b	10	S3-
3c	29	+12V sensor
4a	11	S4+
4b	12	S4-
4c	4	PWM 1TX
5a	14	S5+
5b	15	S5-
5c	27	GND
6a	16	S6+
6b	17	S6-
6c	13	Optional 5 Reg. feedback
7a	18	S7+
7b	19	S7-
7c	33	Option 1 4-20mA
8a	37	S8+
8b	36	S8-
8c	32	Option 2 Frq
9a	35	S9+/Air angle 0-5V
9b	34	S9-/Fan speed 0-5V
9c	not connected	Option 3/Tank gauge
10a	21	On/off+
10b	22	On/off-
10c	not connected	PWM Output option
11a	23	Pressure+
11b	24	Pressure-
11c	28	Flow
12a	20	Foam blop 0-5V
12b	1	option 4 Rx
12c	31	Speed
13a	3	FM L
13b	2	FM R
13c	30	Gnd sensor

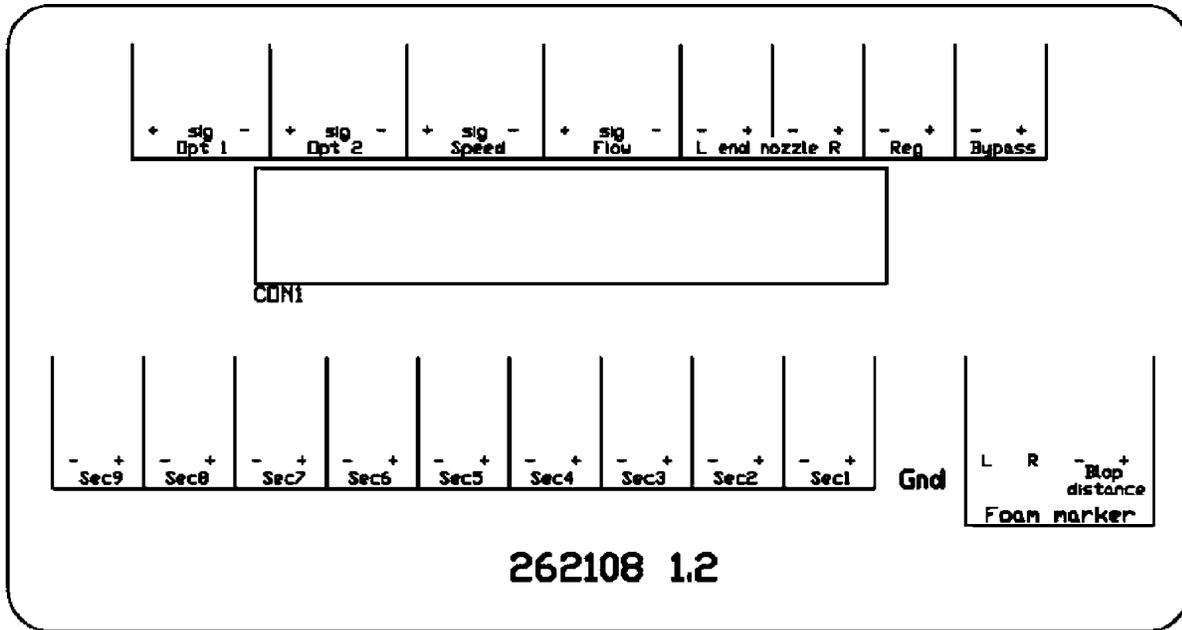


8 - Technical specifications

EFC

The EFC operating unit fulfills the EC noise reduction standards.

When connecting an optional function, be aware that maximum current for every connector is 2 Amp. Total current for the whole connector box may not exceed 10 Amp.

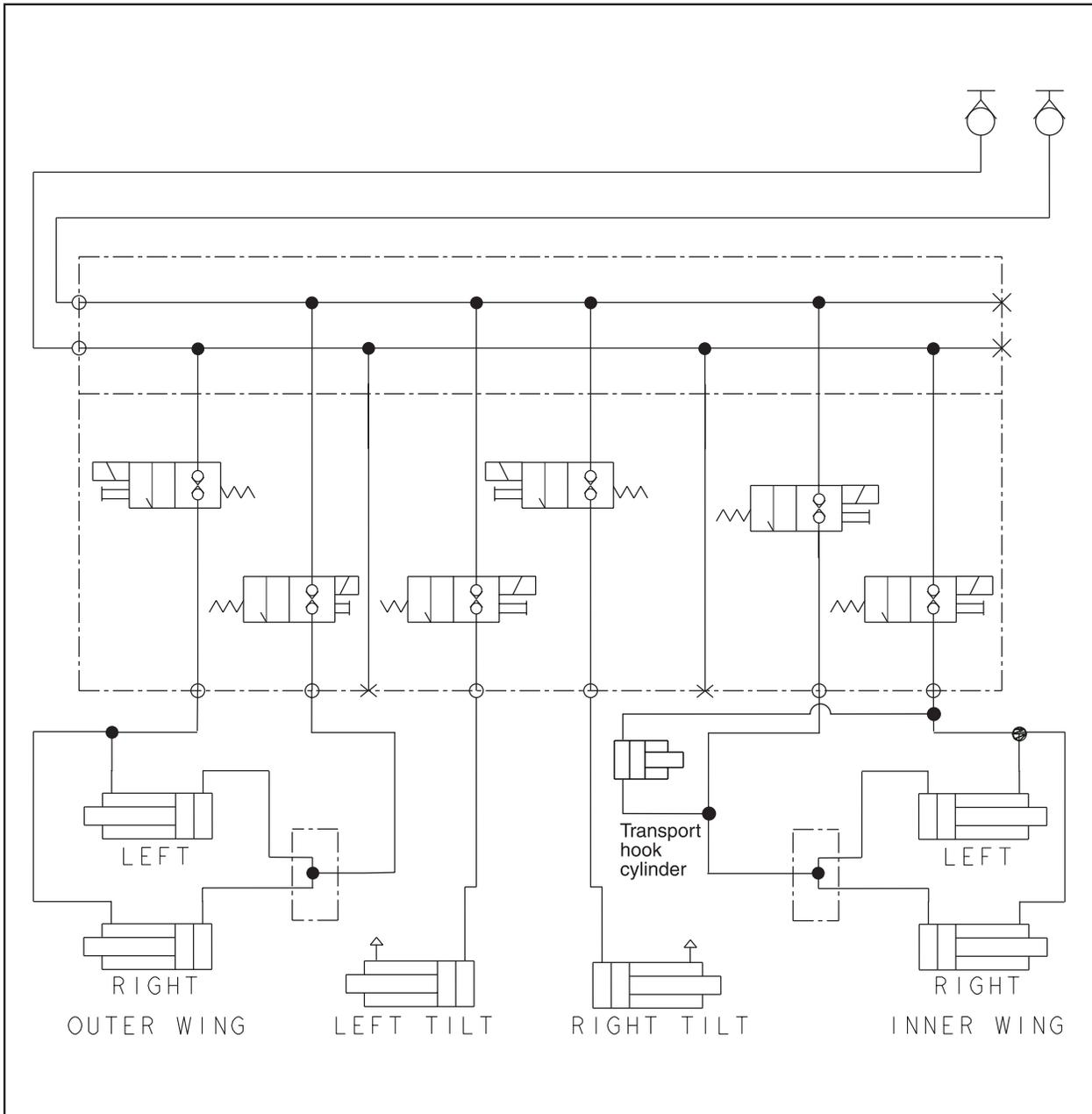


HC 5500	Function	+	Sig.	-		
Opt 1	Pressure sensor	Brn	Blu	-		
Opt 2	RPM sensor or anemometer	Brn	Blu	Blk		
Speed		Brn	Blu	Blk		
Flow		Brn	Blu	Blk		
L end nozzle	Pendulum lock at HAY/LPY	Brn		Blu		
R endnozzle	Pendulum lock at HAY/LPY	Brn		Blu		
Reg (Yellow)		Brn		Blu		
Bypass	EC on/off	Brn		Blu		
Sec 9	User defined A&B 2	x		x		
Sec 8	User defined A&B 1	x		x		
Sec 7	Twin speed	Brn		Whi		
Sec 6	Twin angle	Yel		Gre		
Sec 5		Brn		Blu		
Sec 4		Brn		Blu		
Sec 3		Brn		Blu		
Sec 2		Brn		Blu		
Sec 1		Brn		Blu		
		Gnd	L	R	-	+
Foam marker	No. 4 Not used	2	6	5	1	3

8 - Technical specifications

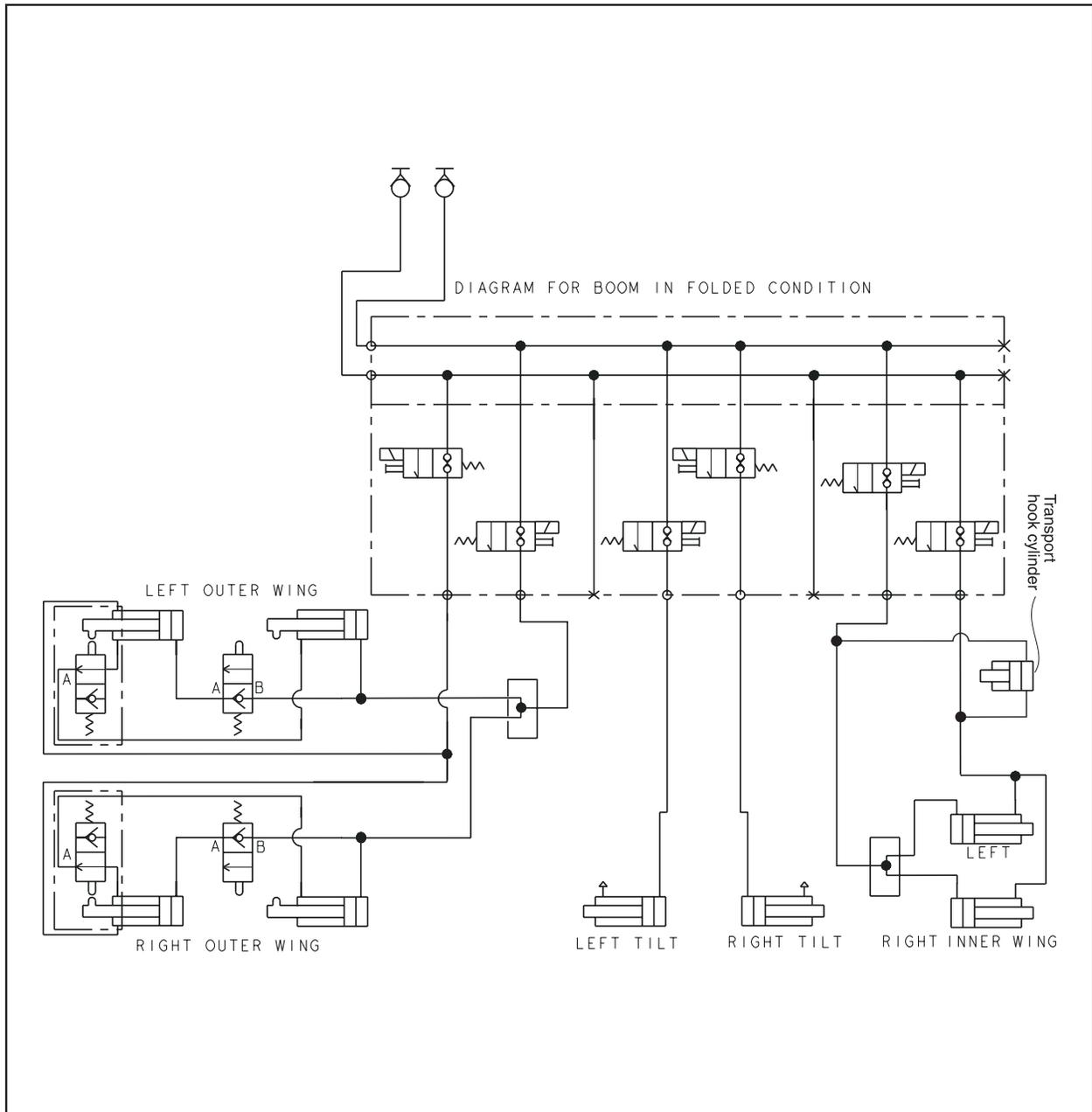
Charts

Force™ Boom hydraulics (2 fold)



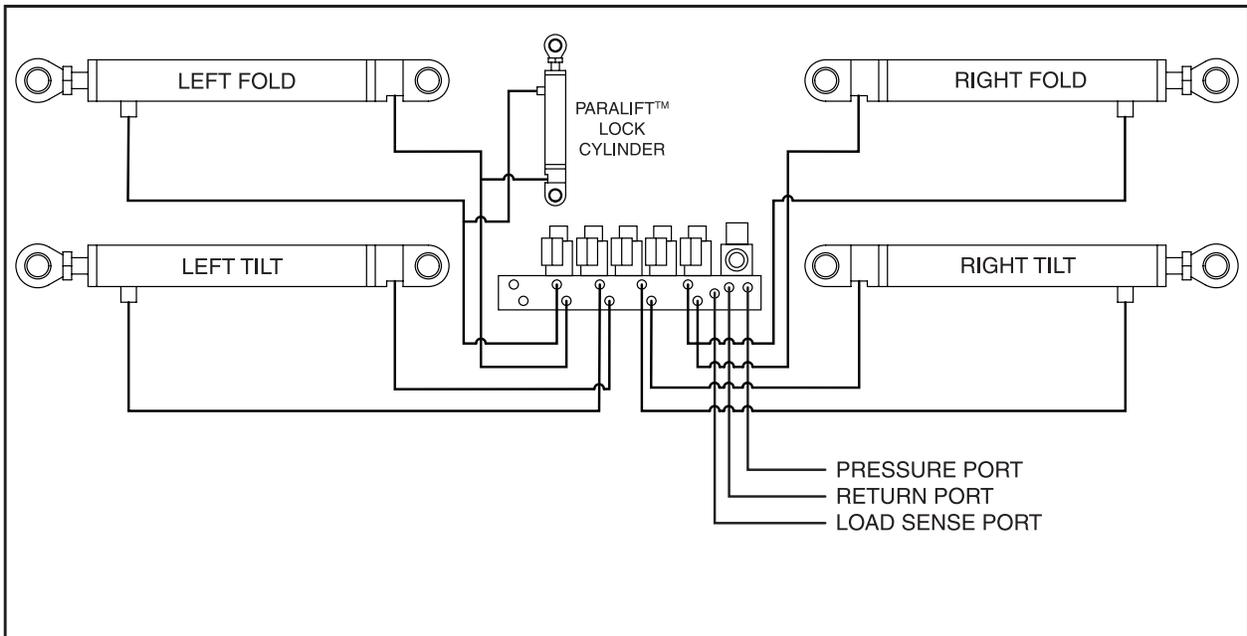
8 - Technical specifications

Force™ Boom hydraulics (3 fold)

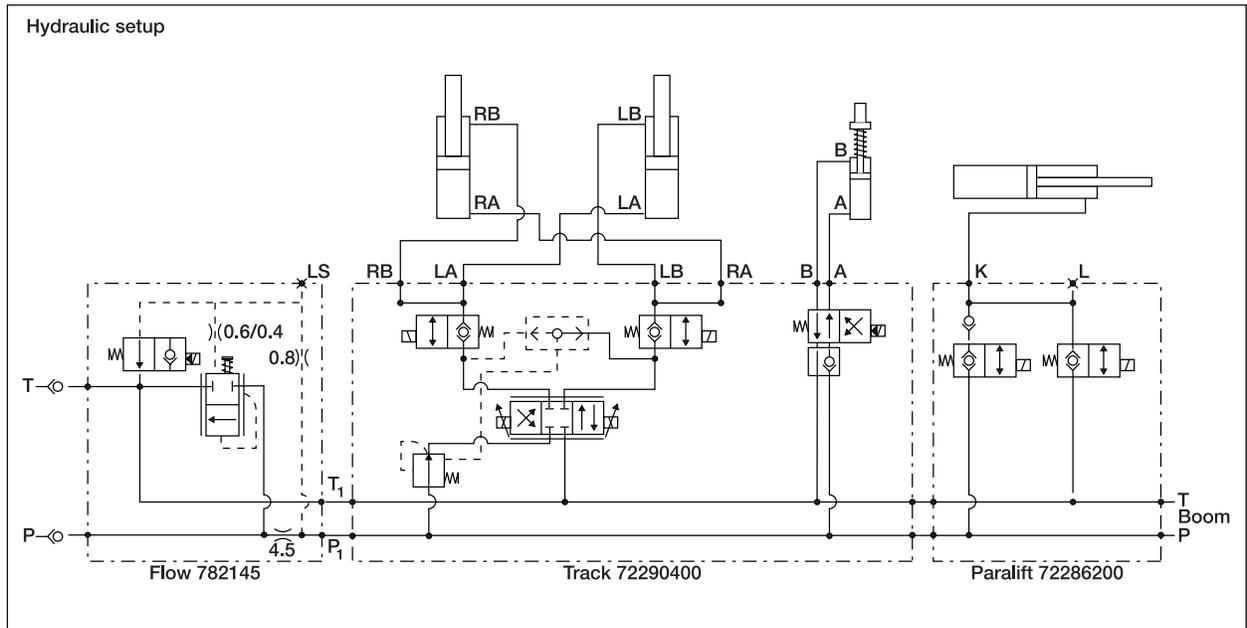


8 - Technical specifications

Eagle™ SPC Boom hydraulics - DH



Sprayer hydraulic



Warranty policy and conditions

HARDI® INC. , 1500 West 76th Street, Davenport, Iowa, USA; 8550 W. Roosevelt Avenue, Visalia, California, USA and 290 Sovereign Road, London, Ontario, Canada hereinafter called "HARDI®", offers the following limited warranty in accordance with the provisions below to each original retail purchaser of HARDI® new equipment of its own manufacturer, from an authorized HARDI® dealer, that such equipment is at the time of delivery to such purchaser, free from defects in material and workmanship and that such equipment will be warranted for a period of one year from the date of delivery to the end user providing the machine is used and serviced in accordance with the recommendations in the Operator's Manual and is operated under normal farm conditions.

1. This limited warranty is subject to the following exceptions:
 - a)Parts of the machine not manufactured by HARDI®, (i.e. engines, tires, tubes, electronic controls, and other components or trade accessories, etc.) are not covered by this warranty but are subject to the warranty of the original manufacturer. Any claim falling into this category will be taken up with the manufacturer concerned.
 - b)This warranty will be withdrawn if any equipment has been used for purposes other than for which it was intended or if it has been misused, neglected, or damaged by accident, let out on hire or furnished by a rental agency. Nor can claims be accepted if parts other than those manufactured by HARDI® have been incorporated in any of our equipment. Further, HARDI® shall not be responsible for damage in transit or handling by any common carrier and under no circumstances within or without the warranty period will HARDI® be liable for damages of loss of use, or damages resulting from delay or any consequential damage.
2. We cannot be held responsible for loss of livestock, loss of crops, loss because of delays in harvesting or any expense or loss incurred for labor, supplies, substitute machinery, rental for any other reason, or for injuries either to the owner or to a third party, nor can we be called upon to be responsible for labor charges, other than originally agreed, incurred in the removal or replacement of components.
3. The customer will be responsible for and bear the costs of:
 - a)Normal maintenance such as greasing, maintenance of oil levels, minor adjustments, etc.
 - b)Transportation of any HARDI® product to and from where the warranty work is performed.
 - c)Dealer travel time to and from the machine or to deliver and return the machine from the service workshop for repair.
 - d)Dealer traveling costs.
4. Parts defined as normal wearing items, (i.e. tires and V-belts) are not in any way covered under this warranty.
5. This warranty will not apply to any product which is altered or modified without the express written permission of HARDI® and/or repaired by anyone other than an Authorized Service Dealer.
6. Warranty is dependent upon the strict observance by the purchaser of the following provisions:
 - a)That this warranty may not be assigned or transferred to anyone.
 - b)That the Warranty Registration Certificate has been correctly completed by dealer and purchaser with their names and addresses, dated, signed and returned to the appropriate address as given on the Warranty Registration Certificate.
 - c)That all safety instructions in the operator's manual shall be followed and all safety guards regularly inspected and replaced where necessary.
7. No warranty is given on second-hand products and none is to be implied.
8. Subject to the following terms, conditions and contributions, HARDI® extends the warranty on polyethylene tanks (excluding fittings, lids and gaskets) to FIVE YEARS. To qualify for this extended warranty, the tank must be drained and flushed with fresh water after each day of use. HARDI®'s liability is limited to replacement of the tank, FOB our plant at no cost to the purchaser during the first twelve months; at 20% of the then current price during the second year ; at 40% during the third year ; at 60% during the fourth year; and at 80% during the fifth year. This five year extended warranty is subject, in each instance, to the tank being inspected and approved for replacement or repair by HARDI® personnel before HARDI® will accept any liability hereunder.

9 - Warranty

9. Subject to the following terms, conditions, contributions, HARDI® extends the warranty on HARDI® diaphragm pumps (excluding wearing parts such as diaphragms, valves, etc.) to FIVE YEARS. To qualify for this extended warranty, the pump must be drained and flushed with fresh water after each day of use. HARDI®'s liability is limited to replacement of defective parts, FOB our plant at no cost to the purchaser during the first twelve months after date of purchase, at 20% of the then current retail price during the second year ; at 40% during the third year ; at 60% during the fourth year ; and at 80% during the fifth year. This five year extended warranty is subject, in each instance, to the pump being inspected and approved for replacement or repair by HARDI® personnel before HARDI® will accept any liability hereunder.
10. HARDI® reserves the right to incorporate any change in design in its products without obligation to make such changes on units previously manufactured.
11. The judgement of HARDI® in all cases of claims under this warranty shall be final and conclusive and the purchaser agrees to accept its decisions on all questions as to defect and to the exchange of any part or parts.
12. No employee or representative is authorized to change this warranty in any way or grant any other warranty unless such change is made in writing and signed by an officer of HARDI® at it's head office.
13. Any warranty work performed which will exceed \$400.00 MUST be approved IN ADVANCE by the Service Manager.
14. Any pump replacement must be approved in advance by the Service Manager.
15. Claims under this policy must be filed with HARDI® within thirty (30) days of work performed or warranty shall be void.
16. Parts requested must be returned prepaid within thirty (30) days for warranty settlement.
17. Warranty claims must be COMPLETELY filled out properly or will be returned.

DISCLAIMER OF FURTHER WARRANTY

THERE ARE NO WARRANTIES, EXPRESSED OR IMPLIED, EXCEPT AS SET FORTH ABOVE. THERE ARE NO WARRANTIES WHICH EXTEND BEYOND THE DESCRIPTION OF THE PRODUCT CONTAINED HEREIN. IN NO EVENT SHALL THE COMPANY BE LIABLE FOR INDIRECT, SPECIAL OR CONSEQUENTIAL DAMAGES (SUCH AS LOSS OF ANTICIPATED PROFITS) IN CONNECTION WITH THE RETAIL PURCHASER'S USE OF THE PRODUCT.