



*mercury*  
**Operator's Manual**

67301503 (04/03)

HARDI® reserves the right to make changes in design,  
material, or specification without notice thereof.  
HARDI® and other product names are registered trademarks  
of HARDI® Inc. in the U.S. and in other countries.



---

**Index**

---

<b>Description.....</b>	<b>5</b>	<b>Axial blower units.....</b>	<b>26</b>
Zone concept.....	5	Optional deflectors .....	26
Basic description of the machine.....	6	V-L Deflector.....	26
Frame .....	6	JET Deflector.....	26
Tank.....	6	Channel kit .....	26
Pump.....	6	Safety grills.....	27
Manifold system .....	6	Angling of the fan blades .....	28
Axial blower .....	6	Air outlet width adjustment .....	30
Filters.....	6	Gearbox oil change .....	31
Identification plate .....	6	Air flow and power consumption charts:	
Use of the sprayer .....	7	UNIT SF45 .....	32
Recommendations .....	7	UNIT SF65 .....	33
<b>Safety instructions .....</b>	<b>8</b>	UNIT SF85 .....	34
Operating the sprayer safely .....	8	<b>Maintenance.....</b>	<b>35</b>
Handling chemical products safely .....	9	Lubrication.....	35
Local poison information center .....	9	P.T.O. shaft.....	35
Mistblowing technique .....	10	Diaphragm pump.....	35
<b>Connecting the sprayer .....</b>	<b>11</b>	Hyd. controlled section valves....	35
Wheel jackstand .....	11	Drawbar.....	36
Drawbars .....	12	Axles.....	36
Swivel drawbar (standard) .....	12	Filters and fittings .....	36
Turnable hitch drawbar.....	12	Diaphragm pumps.....	37
Adjusting the drawbar length .....	13	Nozzles.....	37
P.T.O. shaft .....	13	Maintenance intervals .....	38
Installation of P.T.O. shaft.....	14	<b>Cleaning - Basic concepts.....</b>	<b>39</b>
Wheel types.....	15	Cleaning procedures .....	39
Axle types .....	15	The chemical product.....	39
Suspension.....	16	Legislation .....	39
Hydraulic system .....	17	Cleaning and the soakaway .....	39
<b>Setting up.....</b>	<b>18</b>	The sprayer .....	39
Suction filter.....	18	Cleaning the sprayer .....	40
Cleaning the Suction Filter .....	18	Unforeseen interruptions .....	40
Pressure filters .....	19	<b>Off-season storage.....</b>	<b>41</b>
Fan .....	19	Off-season storage.....	41
Main tank.....	20	Preparation after off-season storage..	42
Clean water tank .....	21	<b>Troubleshooting .....</b>	<b>43</b>
Nozzles.....	21	<b>Technical data.....</b>	<b>46</b>
Agitation.....	22	Dimensions.....	46
Powder mixer .....	22	Weights .....	46
<b>Operating the sprayer .....</b>	<b>23</b>	Wheels .....	46
Plumbing diagram .....	23	Diaphragm pumps .....	47
Diaphragm pumps .....	23	<b>General specifications .....</b>	<b>48</b>
Manifold Valve and Pressure Valve ....	24	<b>Warranty Policy and Conditions .....</b>	<b>50</b>
Pressure Manifold Valve.....	24	<b>Notes.....</b>	<b>52</b>
Pressure Regulator Valve.....	24		
Hyd. controlled section valves.....	25		



Dear Owner,

Thank you for purchasing a HARDI® product and welcome to the ever-increasing family of HARDI® sprayer owners.

Our sprayers and accessories are rapidly becoming a familiar sight on North American farms. We believe that this results from growers becoming increasingly conscious of crop protection input costs and the vital need for cost effective spray application equipment.

Please take the time to thoroughly read the Operator's Manual before using your equipment. You will find many helpful hints as well as important safety and operation information.

Some of the features on your HARDI® MERCURY sprayer were suggested by growers. There is no substitute for "on farm" experience and we invite your comments and suggestions.

Please address your correspondence to the Service Manager at one of these branches:

HARDI® MIDWEST  
1500 West 76th St.  
Davenport, Iowa 52806  
Phone: (563) 386-1730  
Fax: (563) 386-1710

HARDI® WEST COAST  
5646 W. Barstow, Suite 101  
Fresno, California 93722  
Phone: (559) 271-3106  
Fax: (559) 271-3107

HARDI® GREAT LAKES  
290 Sovereign Rd.  
London, Ontario N6M 1B3  
Phone: (519) 659-2771  
Fax: (519) 659-2821

Sincerely,

A handwritten signature in black ink, appearing to read "Tom L. Kinzenbaw".

Tom L. Kinzenbaw  
President

## Description



### Zone Concept

The trailed HARDI® MERCURY sprayers are divided into two different zones.

**Working zone:** with ease of use in mind; all the elements for regulating the fluid circuit are located at the front of the machine.

**Application zone:** with operator safety in mind; all the parts that come into contact with chemical products have been located at the rear of the machine.

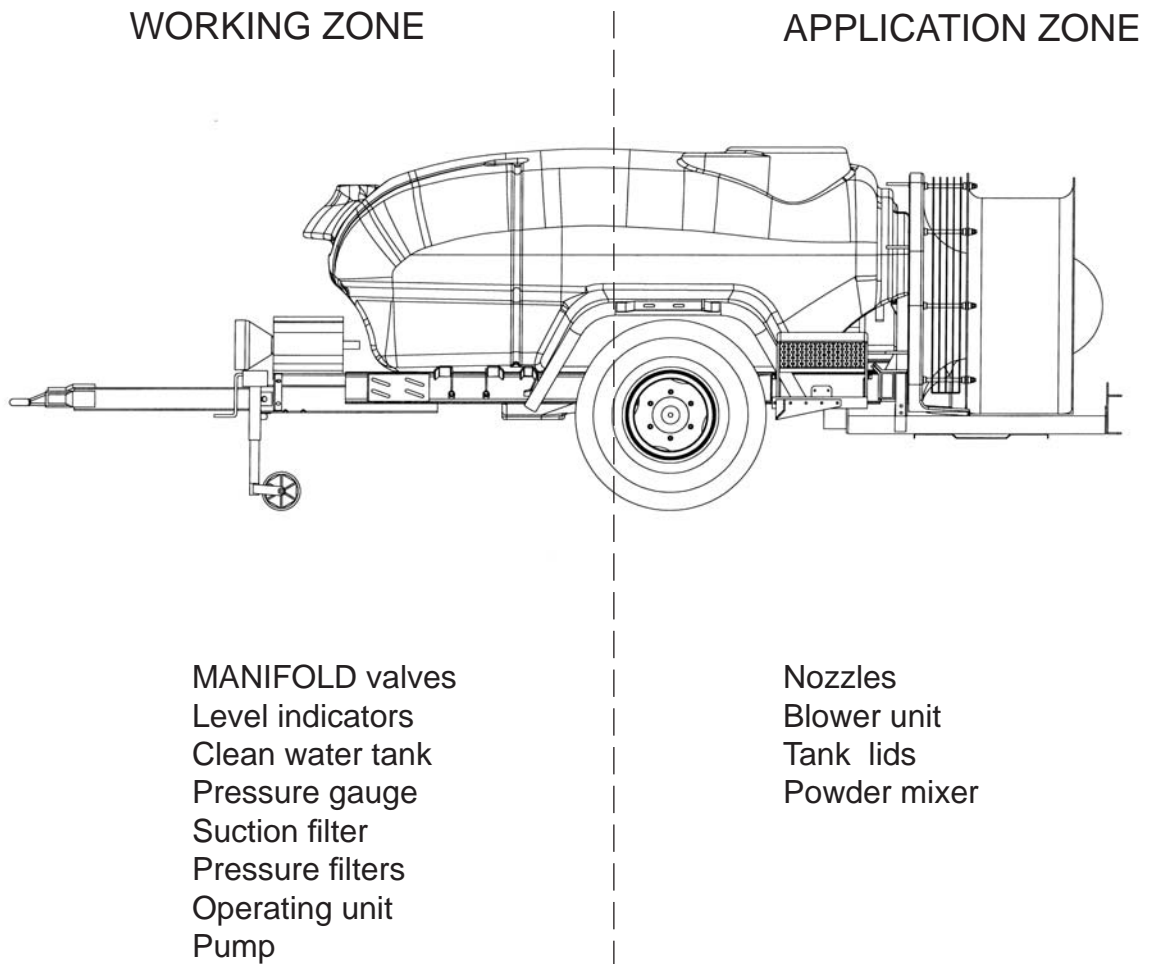



## Description

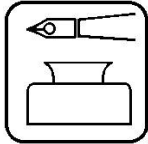

### Basic description of the machine

#### Frame

The frame is manufactured with tensile steel channels providing great durability and resistance to vibration damage.

#### Tank

The tanks are made from UV resistant Polyethylene and designed with smooth, rounded contours to allow for efficient cleaning and draining. Tank capacity: 600 gallons (2300 liters).

#### Pump

Diaphragm pump: 363/7 HD, 540 RPM, PTO driven, 294 PSI (20 bar).

#### Manifold system

Total control of the fluid circuit is carried out by differently colored Manifold valves with pictorial symbols that simplify their use.

#### Axial blower

The blower is designed with thick aluminium fan blades shaped like the wings of a plane. A centrifugal clutch allows for smooth engagement and disengagement.

Different volume rates: 38,000 or 50,000 cfm (65,000 or 85,000 m<sup>3</sup>/hr).

#### Filters

Suction filter: traps impurities present in the liquid, protecting the sprayer's components. Includes an automatic shut-off valve that enables cleaning of the filter when the tank is full.

Pressure filters: permit a large volume rate and high pressure.

#### Identification plate

The identification plate is located on the front, right-hand side of the frame, indicating the model and serial number.

The machine number is engraved on the frame, next to the identification plate.

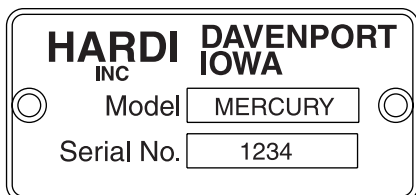
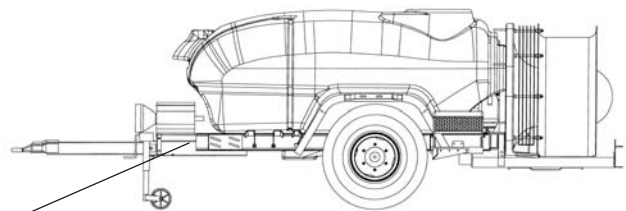

---

## Description

---

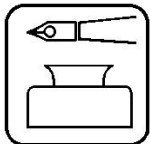

### Use of the sprayer

The HARDI® MERCURY sprayer is designed for the application of chemical crop protection products and liquid fertilizers.

The equipment can only be used for this purpose. Using the sprayer for any other purpose is not permitted.

If no local law requires that the operator must be certified to use the spray equipment, it is strongly recommended to be trained in correct plant protection and in safe handling of plant protection chemicals to avoid unnecessary risk for persons and the environment when doing the spray job.

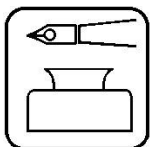

### Recommendations

Although the sprayer has been applied with a strong and protective surface treatment on steel parts, bolts etc. in the factories, it is recommended to apply a film of anticorrosion oil (e.g. CASTROL RUSTILLO or SHELL ENSIS FLUID) on all metal parts in order to prevent chemicals and fertilizers discoloring the enamel. Avoid oil on rubber parts, hoses and tires.

If this is done before the sprayer is put into operation for the first time, it will always be easy to clean the sprayer and keep the enamel shiny for many years.

This treatment should be carried out every time the protective film is washed off.



## Safety Instructions

### SAFETY INFORMATION

#### WARNING



**ALWAYS READ OPERATOR'S MANUAL BEFORE USING EQUIPMENT**

**DO NOT REMOVE ANY SAFETY DEVICES OR SHIELDS. NEVER SERVICE, CLEAN OR REPAIR A MACHINE WHILE IT IS OPERATING**

#### WARNING



**ALWAYS WATCH FOR THIS SYMBOL TO POINT OUT IMPORTANT SAFETY PRECAUTIONS**

**IT MEANS ATTENTION! BECOME ALERT! YOUR SAFETY IS INVOLVED!**

### RECOGNIZE SAFETY INFORMATION



**This is the Safety-alert symbol. When you see this symbol on your machine or in this manual, be alert to the potential for personal injury.**

**Follow recommended precautions and safe operating practices.**

### Follow Safety Instructions

- Carefully read all the safety messages in this manual and the safety labels fitted to the machine. Keep safety labels in good condition. Replace missing or damaged safety labels. Be sure that new equipment components include any current safety labels. Replacement safety labels are available from your authorized HARDI® dealer.
- Learn how to operate the sprayer and how to use the controls properly. Do not let anyone operate the machine without proper instructions.
- Keep your sprayer in proper working condition. Unauthorized modifications or use may impair the function and/or safety and affect the machine's life.

- If you do not understand any part of this manual and need assistance, please contact your authorized HARDI® dealer.

### Operating The Sprayer Safely

1. Read the complete manual carefully and become familiar with the operation of the equipment before initial operation in each spraying season. Failure to do so may result in possible over or under application of spray solution which may drastically affect crop production and lead to personal injury.
2. Before starting the engine on the tractor unit, be sure all operating controls are in the off or neutral position, including (but not limited to) the P.T.O. shaft and/or spray controls. Be sure the tractor power train is disengaged.
3. Operate spray and boom functions only when seated in the operator's seat.
4. One of the most frequent causes of personal injury or death results from persons falling off or being run over. Do not permit others to ride on or in. Only one person should be working the machine when in operation.
5. Before leaving the tractor seat, stop the engine, put all controls in neutral, and put the transmission control lever in the park position or neutral with the brakes locked. Read the tractor operation manual for added safety precautions.
6. P.T.O. driven equipment can cause serious injury. Before working on or near the P.T.O. shaft, servicing or cleaning the equipment, put P.T.O. lever in the DISENGAGE position and stop the engine.
7. Keep hands, feet & clothing away from moving parts.
8. Wear relatively tight and belted clothing to prevent from being caught on some part of the machine.
9. Stay clear of the air inlet and outlet while the fan is in use. Some objects (small stones, etc.) can be expelled from the outlet or clothing can be sucked into the inlet.
10. Always keep children away from your sprayer and/or tractor unit.
11. Slow moving tractors and spray equipment can create a hazard when on public roads. Avoid personal injury or death resulting from any accidents by using flashing lights. Local regulations may require installation of flashing warning lights.



## Safety Instructions

12. Avoid injuries from high pressure fluids penetrating the skin by relieving system pressure before disconnecting hydraulics or other lines. Ensure all fittings are tight before applying pressure to the system.
13. Understand service procedures before undertaking any maintenance. Never lubricate, service, or adjust the machine while it's moving. Securely support any components before working on them.
14. Keep all parts in good condition and properly installed. Fix damaged parts immediately. Replace worn or broken parts. Remove excessive buildup of grease, oil or debris.
6. Extreme care should be taken in measuring spray products. Powders should be used in suitable sized packages or weighed accurately. Liquids should be poured into a suitable graduated container. Keep chemical containers low when pouring. Wear a filtered respirator and let the wind blow away from you to avoid dust and/or splashes contacting the skin or hair.
7. Store chemicals in a separate, plainly marked locked building. Keep the chemical in its original container with the label intact.
8. Dispose all empty containers after rinsing in accordance with local regulations & by-laws. Dispose of all unused chemicals and left over fertilizer in an approved manner.
9. Keep a first aid kit and fire extinguisher available at all times when handling chemicals.

### Handling Chemical Products Safely

1. Direct exposure to hazardous chemicals can cause serious injury. These chemicals can include lubricants, coolants, paints, adhesives and agricultural chemicals. Material Safety Data Sheets (M.S.D.S.) are available for all hazardous chemicals which inform the user of specific details including: physical and health hazards, safety procedures, and emergency response techniques.
2. Protective clothing such as rubber gloves, goggles, coveralls and respirator must be worn while handling chemicals. All protective clothing should be kept in excellent condition and cleaned regularly or discarded.
3. If chemicals come in contact with any exposed skin areas, wash immediately with clean water and detergent. Never place nozzle tips or any other components that have been exposed to chemicals to lips to blow out obstructions. Use a soft brush to clean spray nozzles.
4. Dedicate an area to fill, flush, calibrate and decontaminate sprayer where chemicals will not drift or run off to contaminate people, animals, vegetation, water supply, etc. Locate this area where there is no chance of children coming in contact with this residue.
5. Decontaminate equipment used in mixing, transferring and applying chemicals after use. Follow the instructions on the chemical label for the correct procedure required. Wash spray residue from outside of the sprayer to prevent corrosion.

### Local Poison Information Center

If you live anywhere in the United States, the following toll free number will connect you to your Local Poison Information Center.

**PHONE NO. 1 - 8 0 0 - 2 2 2 - 1 2 2 2**

If you live outside the United States, find the number for the poison control center in your phone book and write it in the space below:

**PHONE NO.** \_\_\_\_\_ - \_\_\_\_\_ - \_\_\_\_\_

Keep a list, in the space provided below, of all the chemicals that you have in use.

1. \_\_\_\_\_
2. \_\_\_\_\_
3. \_\_\_\_\_
4. \_\_\_\_\_
5. \_\_\_\_\_
6. \_\_\_\_\_
7. \_\_\_\_\_
8. \_\_\_\_\_
9. \_\_\_\_\_
10. \_\_\_\_\_



## Safety Instructions

The safety and efficiency of this machine depend entirely on the care it receives. The first important step is to **read carefully and pay attention** to this instruction book which contains essential information on the efficient use and servicing of this high-quality product.

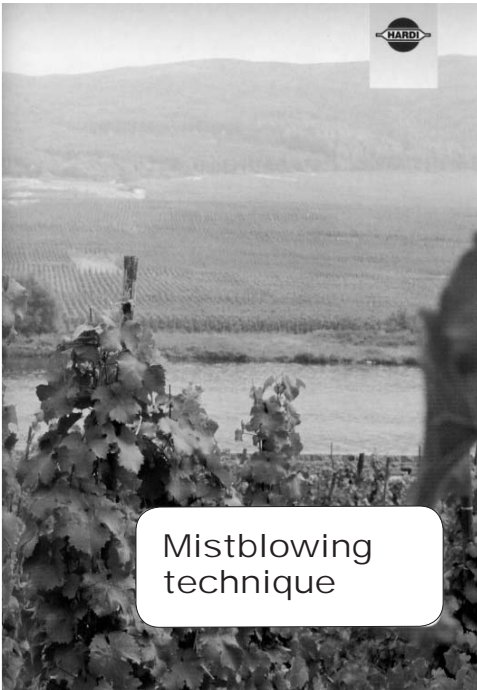

This book should be read in conjunction with the “Mistblowing Technique” manual (#673706, supplied with the equipment), to help you to achieve the best results.

## Connecting the sprayer

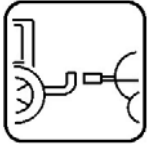

### Wheel jackstand

The HARDI® MERCURY sprayer is equipped with a wheel jackstand. When the sprayer is not attached to the tractor, the wheel jackstand should be locked into Position 1 with the two pins (see photo). The height of the machine can be adjusted by turning handle **A**.

When the sprayer is attached to the tractor, the wheel jackstand should be locked into Position 2 with two pins. This position is designed to fit snugly to the frame and avoid vibrating noises produced by the wheel.

Position 1

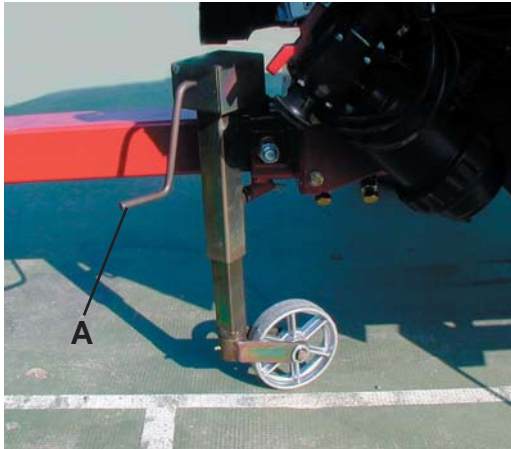

Sprayer unattached

Position 2



Sprayer attached



## Connecting the sprayer

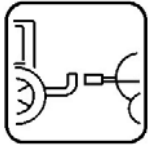

### Drawbars

There are two types of drawbars available for the HARDI® MERCURY sprayer: the swivel drawbar, and the turnable hitch drawbar.

#### Swivel drawbar (standard)

The swivel drawbar is attached close to the body of the tractor. Before connecting the P.T.O. shaft, make sure that the drawbar is firmly attached and that the tractor's wheels do not touch the sprayer when turning.

A P.T.O. shaft with CV (Constant Velocity) joint is needed on the tractor's side. It is possible to adjust the length of the drawbar if necessary (see "Adjusting the drawbar length", page 13).

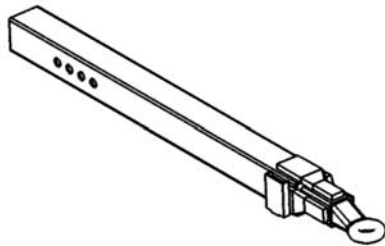

#### Turnable hitch drawbar

The turnable hitch drawbar is connected to the tractor's lower link arms. Before connecting the P.T.O. shaft, make sure that the diameter of the connecting pins is the same diameter as the holes on the tractor's lower link arms. Also make sure that the snap locks are in place and that the tractor's wheels do not touch the sprayer when turning. This hitch type permits the greatest turning angles and requires a P.T.O. shaft with CV joint on the sprayer side. The length of the drawbar is adjustable (see "Adjusting the drawbar length", page 13).

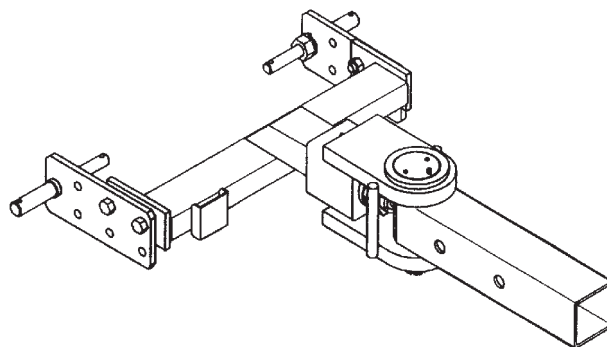

## Connecting the sprayer

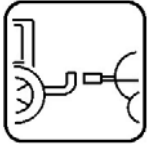

### Adjusting the drawbar length

Steps to follow:

1. Place the wheel jackstand in the position indicated in the photo.
2. Loosen the two bolts **A**, located where the drawbar is attached to the frame.
3. Remove bolt **B**.
4. Place the drawbar in the desired position.
5. Replace bolt **B**, making sure that it passes through the holes in the frame and the drawbar.
6. Tighten the two bolts **A**.

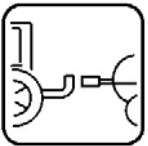
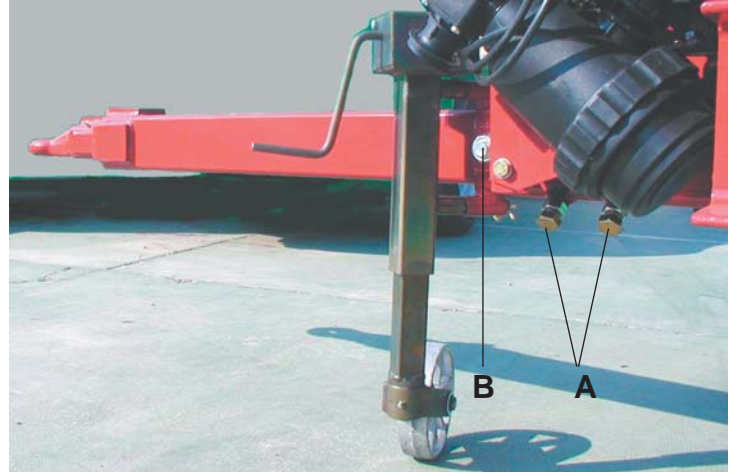

### P.T.O. shaft

#### Operator safety



**WARNING: ALWAYS STOP ENGINE BEFORE ATTACHING THE TRANSMISSION SHAFT TO TRACTOR P.T.O. MOST TRACTOR P.T.O. SHAFTS CAN BE ROTATED BY HAND TO FACILITATE SPLINE ALIGNMENT WHEN ENGINE IS STOPPED.**

When attaching the shaft, make sure that the snap lock is FULLY ENGAGED - push and pull shaft until it locks.



**WARNING: ROTATING TRANSMISSION SHAFTS WITHOUT PROTECTION GUARDS ARE FATAL.**

Always keep protection guards and chains intact and make sure that the guards cover all rotating parts, including CV-joints at each end of the shaft.

Do not use without protection guard.

Do not touch or stand on the transmission shaft when it is rotating - safety distance: min 5' (1.5 meters).

Prevent protection guards from rotating by attaching the chains, allowing sufficient slack for turns.

Make sure that protection guards around the tractor P.T.O. and implement shaft are intact. Always STOP ENGINE and remove the ignition key before carrying out maintenance or repairs to the transmission shaft or implement.



## Connecting the sprayer

### Installation of P.T.O. shaft



**WARNING: THE P.T.O. SHAFT ANGLE WILL CHANGE WHEN RAISING AND LOWERING THE CLEVIS. TO PREVENT EXCESSIVE LOADING AND BINDING ON THE P.T.O. SHAFT, IT MAY BE ADVISABLE TO LEAVE THE P.T.O. SHAFT DISCONNECTED UNTIL THE CLEVIS ADJUSTMENT IS COMPLETED. THEN THE P.T.O. SHAFT ADJUSTMENTS CAN BE MADE.**

Initial installation of the shaft is done as follows:

1. Attach sprayer to tractor and set sprayer in the position with shortest distance between the tractor and sprayer pump P.T.O. shafts.
2. Stop the engine and remove ignition key.
3. If P.T.O. shaft must be shortened, the shaft is pulled apart. Fit the two shaft parts at tractor and sprayer pump and measure how much it is necessary to shorten the shaft. Mark the protection guards.

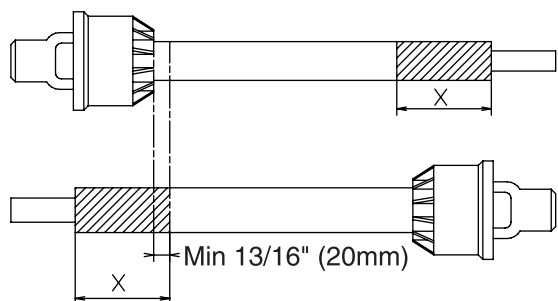

**Note:** The shaft must always have a minimum overlap of 1/3 the length.

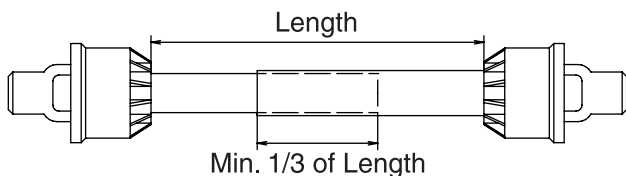

4. The two parts are shortened equally. Use a saw, and file the profiles afterwards to remove burrs.

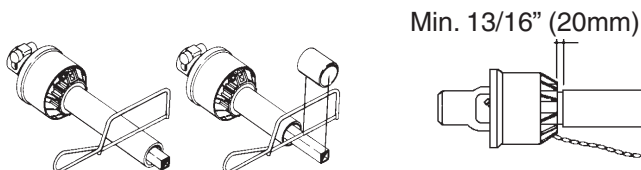

5. Grease the profiles, and assemble male and female parts again.
6. Fit the shaft to tractor and sprayer pump.

**Note:** Female part towards tractor. Fit chains to prevent the protection guards from rotating with the shaft.

7. To ensure long life of the P.T.O. shaft, try to avoid working angles greater than 15°.

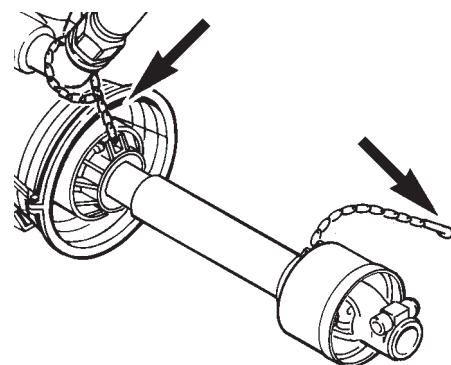
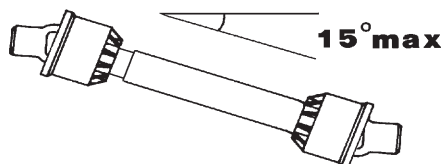

## Connecting the sprayer



### Wheel types

HARDI® MERCURY sprayers are equipped with 12.5L x 15" tires on 15" x 10" x 8 bolt rims.

WHEELS (Tires & Rims)		
Model	Standard	Optional
Mercury 600	12.5L x15"	14Lx16.1" (12 ply)

Working pressure: 32 psi (2.2 bar)

The sprayer's tires should always be at the correct pressure as they act as a suspension system when the tank is full, making the whole assembly less rigid.

Inflation and checking of the tire must always be done when the tire is cold. The sprayer's wheels are IMPLEMENT type and cannot exceed 25 mph (40 km/h) when fully loaded.

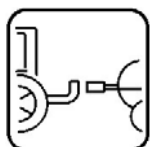

### Axle types

HARDI® MERCURY sprayers are equipped with a fixed axle. Two different tread widths are possible by reversing the rims on the hubs:

Standard 53" between tire centers (Rims on with valve stem facing out)

Reverse 48" between tire centers (Rims on with valve stem facing in)

FIXED AXLE

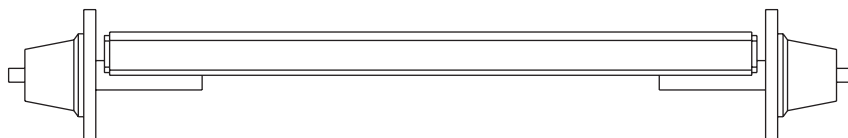

The fixed axle is mounted in a housing bolted directly to the frame. This gives five different settings to improve the stability of the machine when necessary.

The standard position of the housing is the 3rd from the rear of the sprayer (as indicated in the photo).

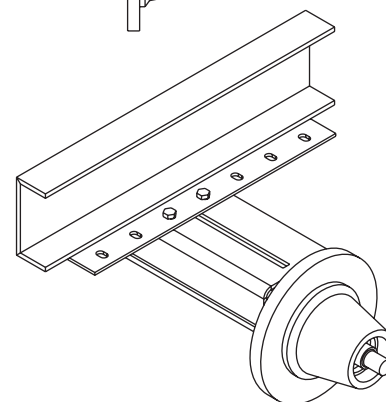



## Connecting the mistblower

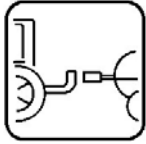

### Suspension

The frames of HARDI® MERCURY sprayers can be fitted with a novel and exclusive torsion suspension system that is capable of smoothing and absorbing irregularities in the terrain. This system improves safety on long trips over rough terrain and reduces time spent on trips for filling, etc...



Suspension kit is added to the housing.



Anchored to the frame by three bolts.

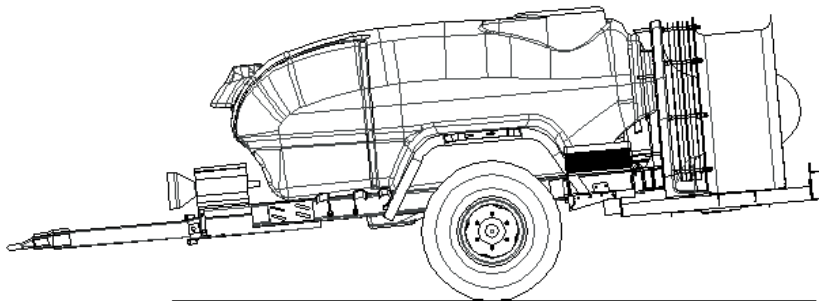

ACTIVE SUSPENSION

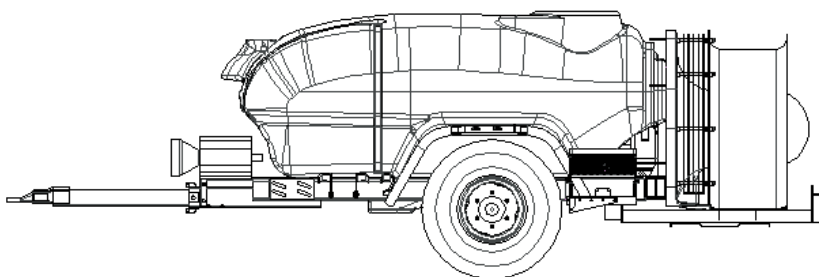

PASSIVE SUSPENSION

The suspension is ACTIVE when the machine is load-free, and it gets lower as the tank is filled. When the tank of the sprayer reaches half-full, the suspension is PASSIVE, as the machine will only tilt if there is a very pronounced unevenness in the terrain.

**NOTE.** Use of the suspension with the swivel drawbar is recommended for those machines which frequently cover long distances over uneven terrain.



---

## Connecting the sprayer

---



### Hydraulic system

Connection requirements for HARDI® MERCURY sprayers are:

- Two single acting outlets (one for each hydraulically controlled section valve).



**BE SURE TO HOOK UP HYDRAULIC LINES PROPERLY!**

**ENSURE HYDRAULIC LINES HAVE NOT BEEN DAMAGED DURING SHIPPING.**

**ESCAPING HYDRAULIC FLUID UNDER PRESSURE CAN PENETRATE THE SKIN CAUSING SERIOUS INJURY. AVOID THIS HAZARD BY RELIEVING PRESSURE BEFORE DISCONNECTING HYDRAULIC LINES.**

**ENSURE ALL CONNECTIONS ARE TIGHT BEFORE APPLYING PRESSURE, SEARCH FOR LEAKS WITH A PIECE OF CARDBOARD, NOT YOUR HANDS!**

**ALWAYS SHUT TRACTOR OFF WHEN CONNECTING, SERVICING OR ADJUSTING ANY HYDRAULIC COMPONENTS.**

Make sure that the hydraulic couplers are clean before connecting to the tractor's remote outlets.



**IMPORTANT!** Due to the variation in tractor hydraulic systems and capacities, care should be exercised when initially operating the sprayer hydraulic section valves. It is advisable to adjust the hydraulic flow down to the minimum rate before operating the system. Adjust/increase the flow control after the system is bled of any air, if necessary.



## Setting up



### Suction filter

The suction filter is located at the front of the sprayer near the pump. Its primary purpose is to protect the pump from damage. It contains an automatic shut off valve to allow the operator to clean and service the filter with a full tank.

#### Cleaning the Suction Filter

Turn the yellow handle counter-clockwise until it “pops out”. This closes an internal valve to prevent the main tank from draining when cleaning the filter. Unscrew the large plastic nut and remove the lid. Remove the filter for cleaning, being very careful not to damage the O-ring of the filter lid. This would allow air to enter during suction and cause rattling of hoses and continual pressure variations. To help prevent this, it is advisable to lubricate the o-ring with vegetable oil before closing the lid. Finally, replace the yellow valve handle and lock into position to allow flow through the filter.



**Warning.** The suction filter is one of the most important elements of the fluid circuit. The ability of the pump to take in air correctly largely depends on how well the filter has been cleaned and maintained. It is necessary to clean the filter after every working day in order to keep the filter free of blockage.

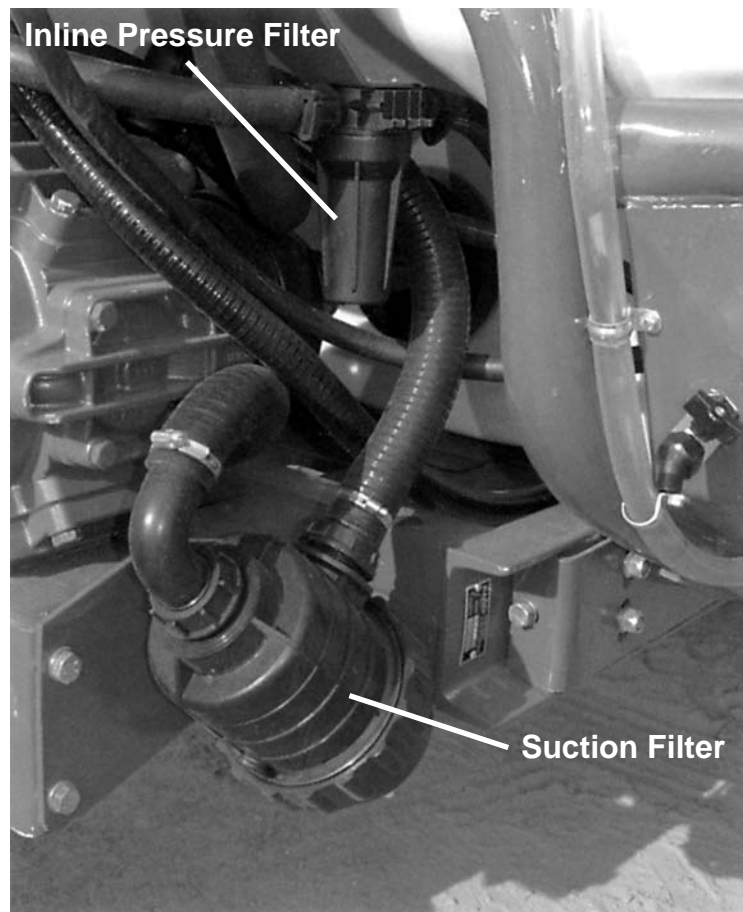

## Setting up



### Pressure filters

The Mercury sprayers are equipped with in-line pressure filters to provide a clean flow of liquid to the nozzles. This is the last filter before the nozzles, and will prevent the nozzles from becoming clogged with leftover product residue solidifying in the hoses.

The in-line filters should be cleaned daily. Unscrew the filter bowl to inspect and clean the filter. Lubricate the O-ring with vegetable oil.

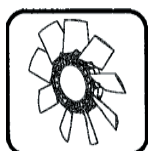
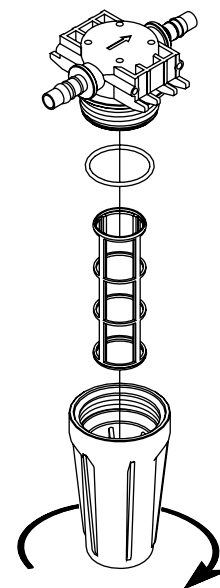





### Fan

When working with spray guns or just liquid agitation, use of the fan is not required and it is recommended to disconnect it.



**WARNING.** Both the pump and the fan must be completely at rest when the position (speed) of the fan gear box is changed.

The gearbox is located behind the tank. Place the handle in the neutral position  to prevent the fan from turning with the functioning PTO, in the position  to work with a slow air speed, or in the position  for a fast air speed.

If the sprayer is equipped with a single-speed gearbox, it will only be possible to choose between neutral  and the fast speed .

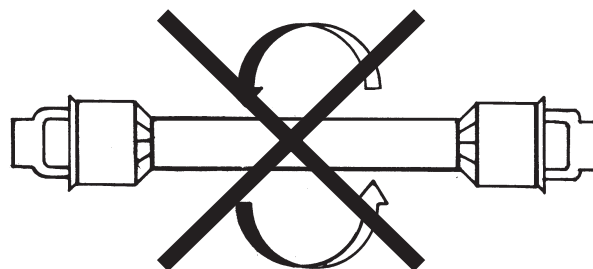
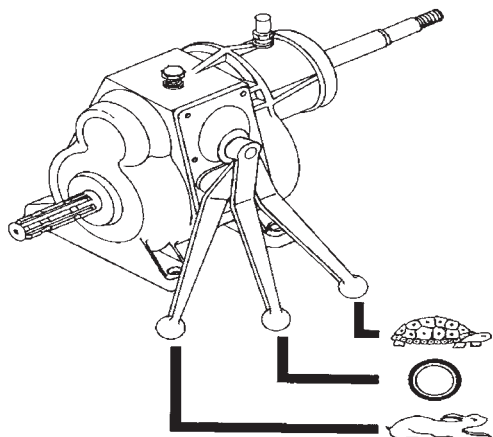

### NOTE.

If you encounter any difficulty when changing the gear on the fan, it is because the gear teeth are touching those on the large tooth-wheel and preventing them from falling into place. In this case the fan should be made to rotate again, then stopped, and a new attempt made.

## Setting up

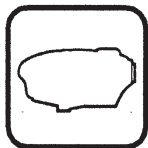

### Main tank

To fill the tank with water, remove the lid found on top of the tank; there are two lids located at the back of the tank for easy filling from either side of the sprayer. Always use water as clean as possible. Always fill the tank with the filter basket correctly in place to prevent impurities from entering the tank.

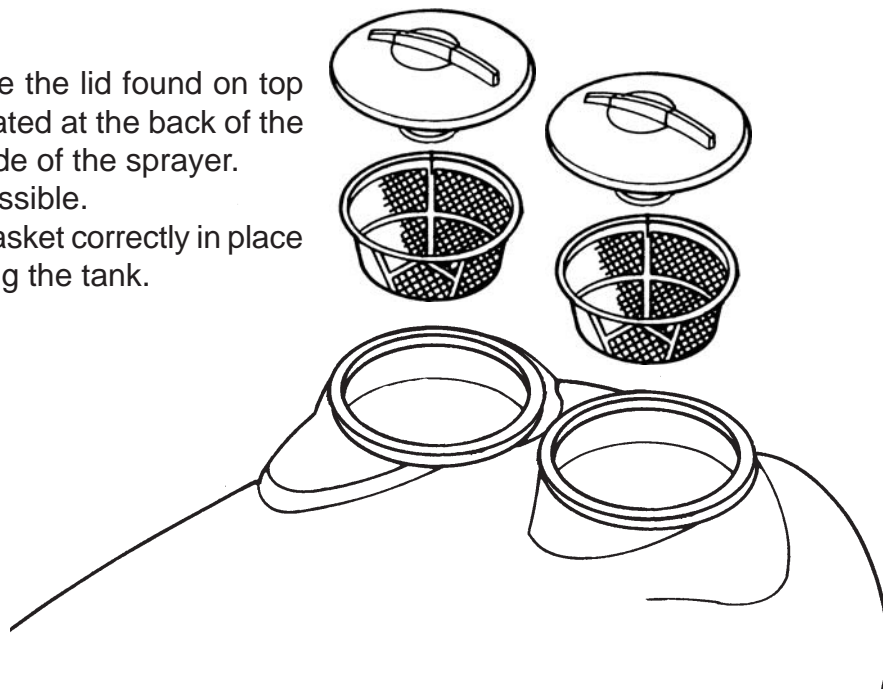

**WARNING.** Do not place the filling hose inside the tank. Keep it out of the tank at all times and only point it towards the inside. If the hose were inside the tank and the pressure from the water supply point dropped, the chemical products could be siphoned from the tank to the water supply, contaminating the water therein (A).

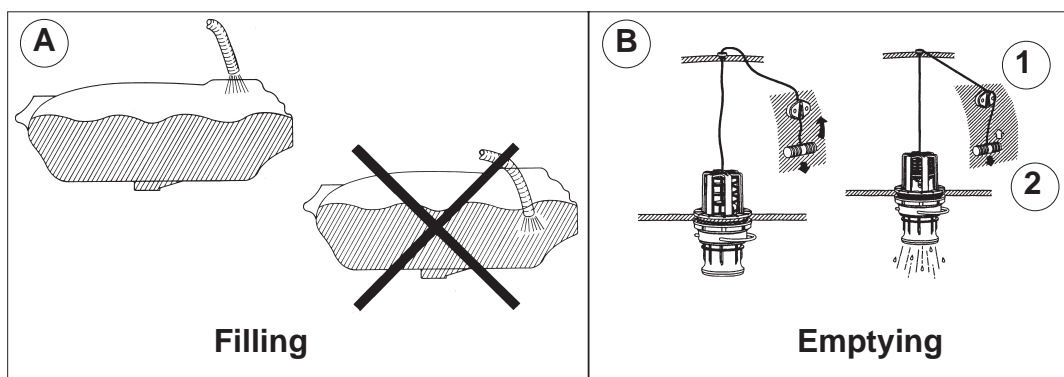

To empty the tank with the drain valve, pull the red handle located on the upper left-hand side. The valve is spring-loaded to return it to the closed position, but can be kept open by pulling the string out and upwards into the V-shaped slot (1). To close the drain valve again, pull the red handle down and release (2). The valve will close automatically (B).

## Setting up



### Clean water tank

The clean water tank has a capacity of 4 gallons (15 liters) and is situated at the front of the machine. It is used for washing gloves or hands that have been in contact with the chemical product. The valve **A** for releasing the water is attached by a bracket to the front left-hand side.

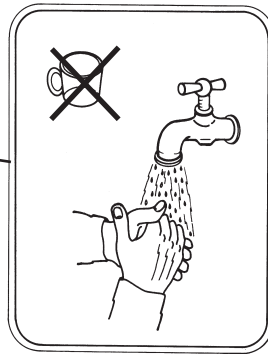
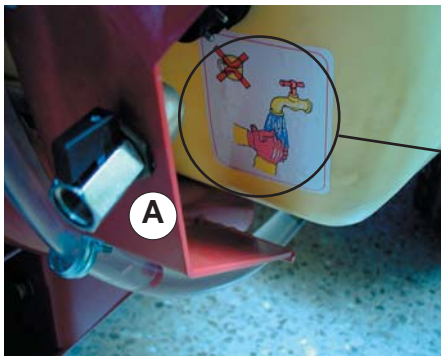

**WARNING.** The water in this tank is not for drinking.

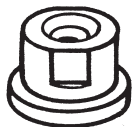

### Nozzles

The nozzles can be shut off individually by turning them 90°. When open, the nozzle has 3 different positions, all of which are readily interchangeable. Turning them slightly in either direction will produce a noticeable click.

The nozzle holders are fitted with a non-drip valve **1** which prevents loss of remaining product in the tubes after the sections have been closed.

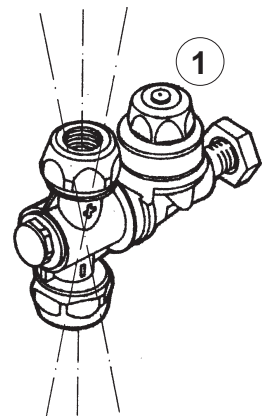

## Setting up

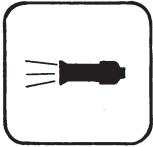

### Agitation

The agitation system is the "venturi" type, which pressure injects the product from the pump together with the return chamber flow.

The agitator is standard fitted with a 5 mm restrictor (A). This restrictor creates a high pressure flow which enters the main tank, provoking turbulence and ensuring a perfect mix of product and water.

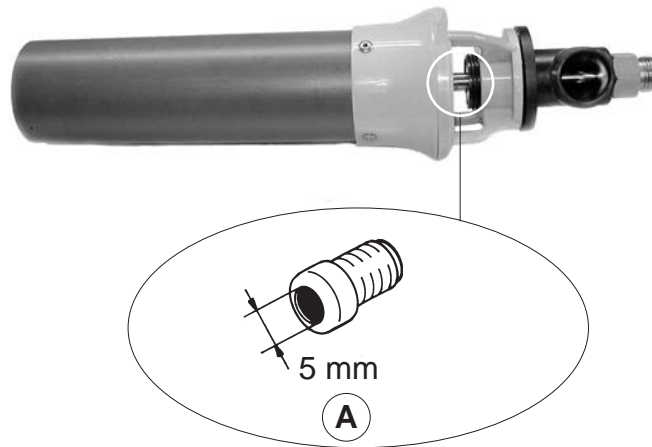

The restrictor should be replaced in the following way:

- 1 With the help of a spanner, undo the nut on the inside of the agitator.
- 2 Undo the restrictor screwed into the stainless steel tube.
- 3 Put teflon on the new restrictor and screw it in.
- 4 Replace this assembly in the agitator.



### Powder mixer

The sole function of the Powder mixer is to rinse the filter basket on the main tank's filling device when adding powdered products that do not dissolve properly and would otherwise form lumps on contact with the water in the tank.

After using the powder mixer it must be **turned off**, as it uses a large amount of the available flow.

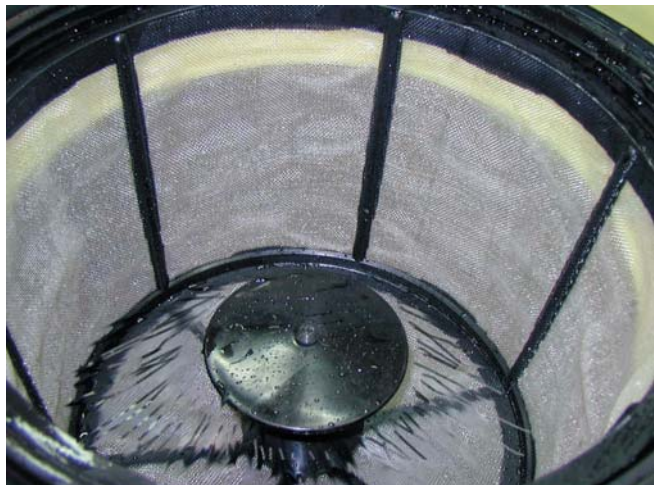

## Operating the sprayer



### Plumbing diagram

The HARDI® MERCURY sprayers use manually controlled operating units with hydraulically controlled section valves.

mercury 600 - HC/2

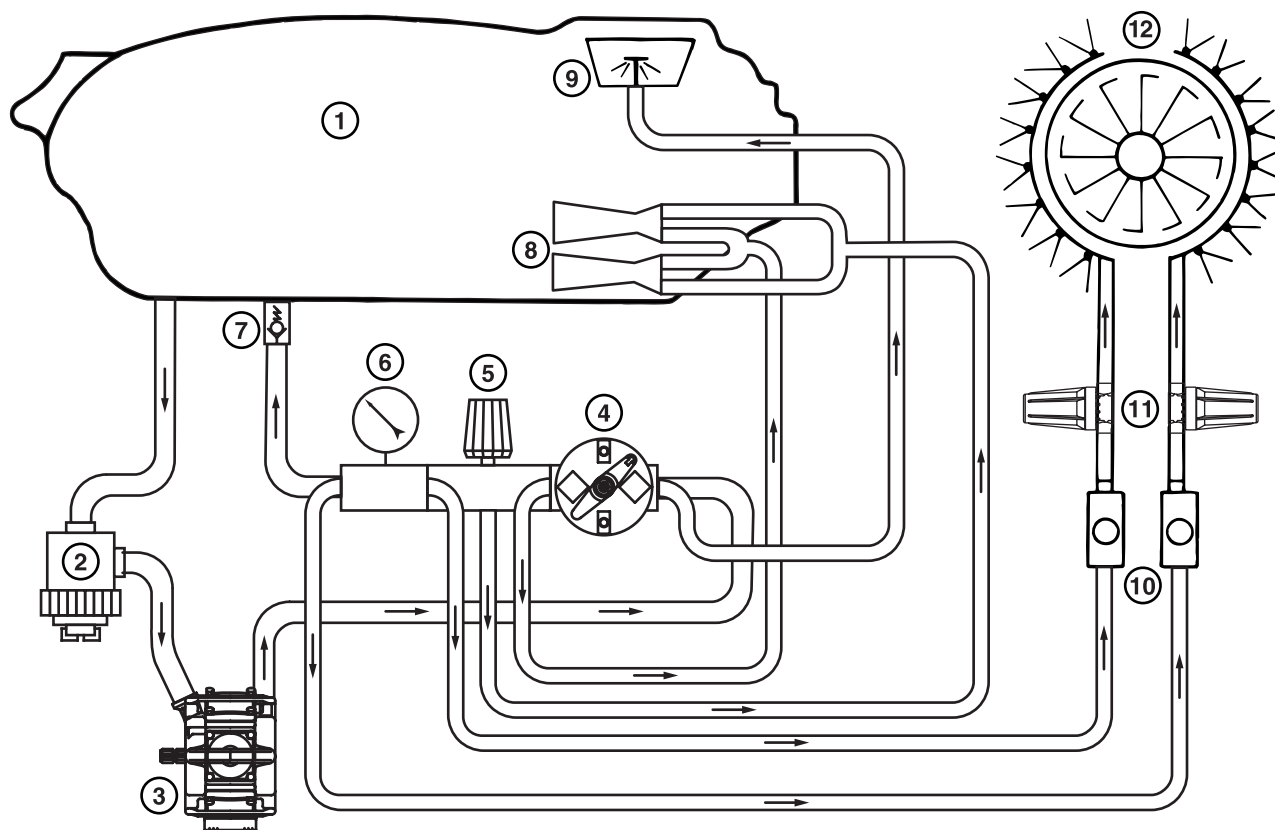

- |                                 |                                     |
|---------------------------------|-------------------------------------|
| 1. Main tank                    | 7. Safety valve                     |
| 2. Suction filter               | 8. Agitation                        |
| 3. Pump                         | 9. Powder mixer                     |
| 4. Agitation/Powder mixer valve | 10. Hydraulic remote section valves |
| 5. Pressure regulator           | 11. Pressure filters                |
| 6. Manifold pressure gauge      | 12. Blower nozzles                  |

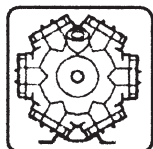

### Diaphragm pumps

The HARDI® diaphragm pumps are low pressure pumps of rugged construction. They are lubricated with grease through the grease nipples that are located on the crankshaft.

The 363/7 HD diaphragm pump has six diaphragms and a flow rate up to 37.0 gpm (140 l/min) at 540 rpm.

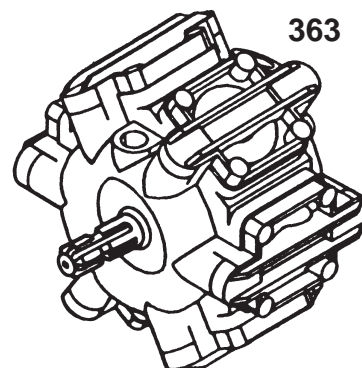

363



## Operating the sprayer



### Manifold Valve and Pressure Valve

The sprayer controls are located at the front of the sprayer. They consist of one manual pressure manifold valve and one pressure regulator valve.

#### Pressure Manifold Valve

The pressure manifold valve has three positions:

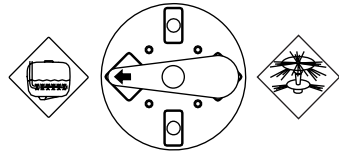

Pressure agitation

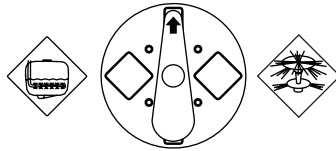

Off

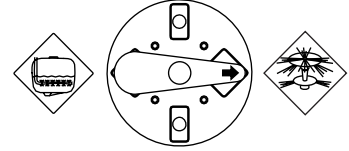

Powder mixer

Turn the valve to the left to send pressure to the agitator (fast agitation). Turn the valve to the right to operate the powder mixer, which will clean any product residues from the filter basket. Turn the valve straight up or down to turn both features off.

**Note:** When pressure agitation is not selected, there is still return (slow agitation) to the tank.

#### Graphic symbol descriptions

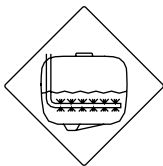

Pressure agitation

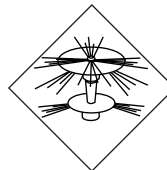

Powder mixer

#### Pressure Regulator Valve

The pressure regulator valve is centrally located for easy calibration and allows for simple change of application rates. The 4" pressure gauge located nearby is easy to read from the ground or tractor.

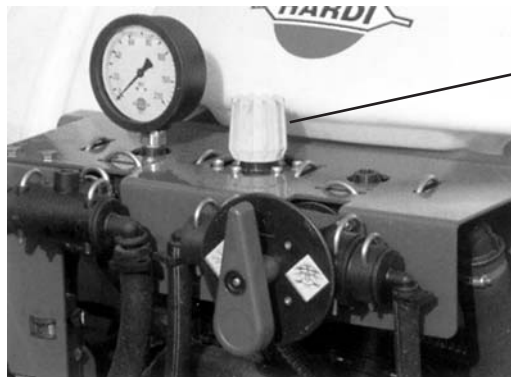

Pressure regulator valve



---

## Operating the sprayer

---



### Hydraulically controlled section valves

The left and right blower nozzles are turned on and off by the left and right hydraulic section valves.

Make sure each hydraulic hose is connected to a separate single-acting hydraulic outlet on the tractor. The nozzles for each section are turned "On" by pushing the hydraulic lever for that section in one direction, and turned "Off" by pushing the hydraulic lever for that section in the opposite direction. The hydraulic lever can be returned to the neutral position after switching a section "On" or "Off".

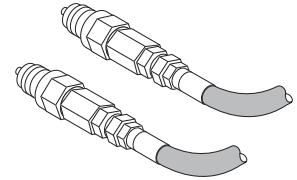

If you do not like the direction required to activate a nozzle section, switch positions of the hose in the single-acting outlet for that section.

## Axial blower units



### Optional deflectors

V-L De-  
flector

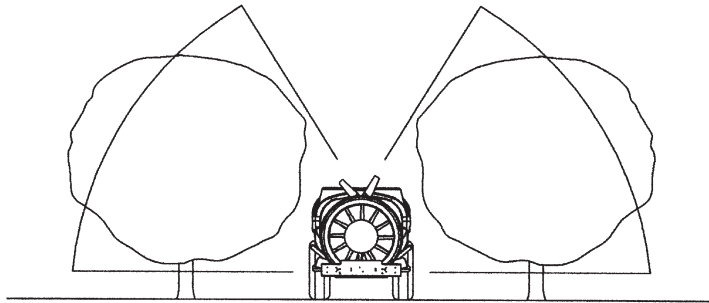
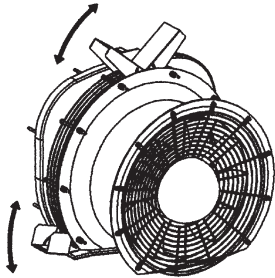

Orchards in general: fruit trees, citrus and unirrigated.

JET De-  
flector

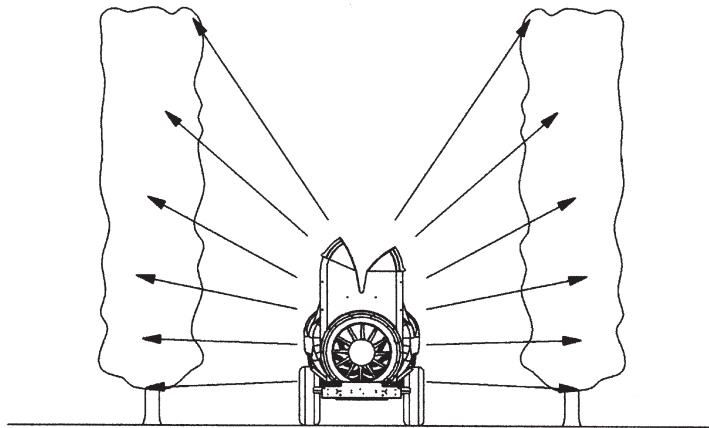
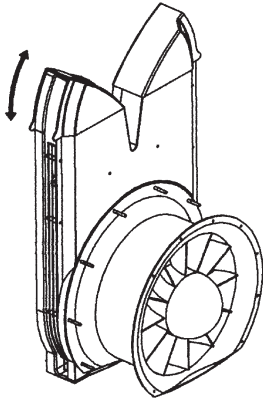

Orchards in palmeta.

Channel  
Kit

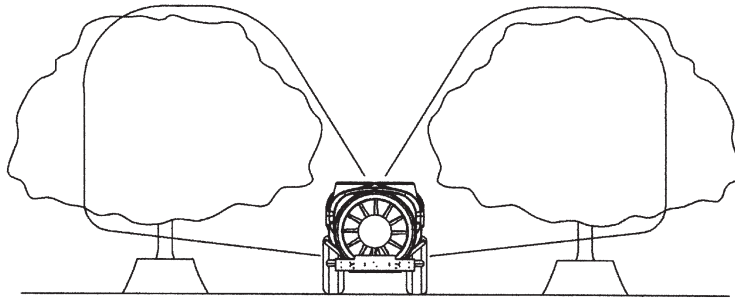
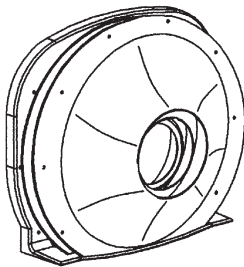

Intensive fruit tree and citrus orchards .

## Axial blower units

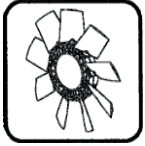

### Safety grills

All models of axial blower units are equipped with safety grills. These are essential for preventing accidents and the entrance of foreign objects into the blower.



#### WARNING.

The use of the blower unit without safety grills is absolutely **FORBIDDEN**.

Do not remove safety grills with the machine is in use.

Do not approach a blower in use wearing light or loose clothing.

Do not introduce foreign objects into the safety grills whether the blower is in use or not.

During the working day, wear proper hearing protection to protect your hearing from the noise produced by the blower.

In the case of vibrations or knocking, stop the blower immediately.

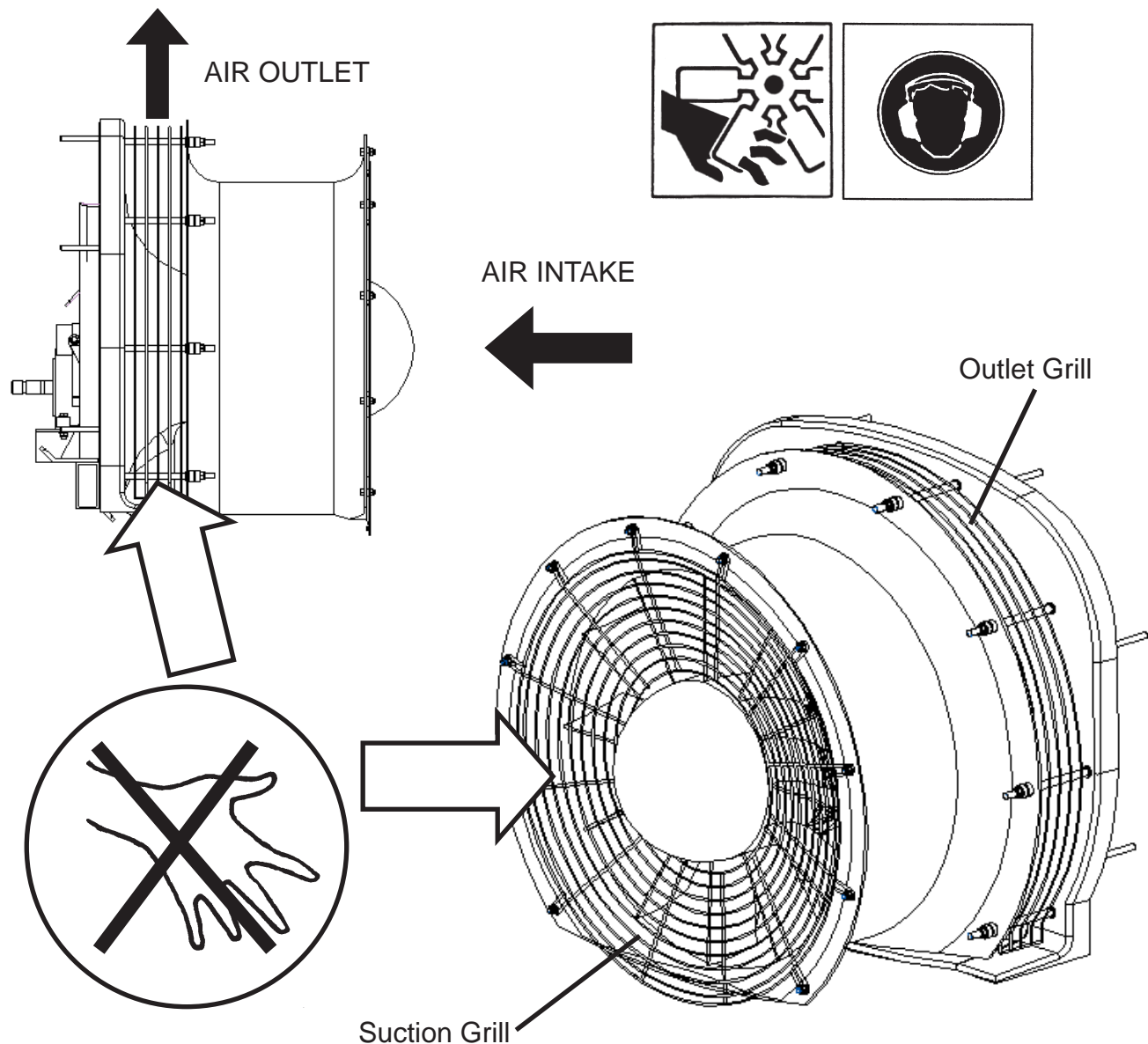

## Axial blower units

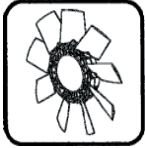

### Angling of the fan blades

The angle of the fan blades can be adjusted through three positions. The standard factory setting is the second, or middle, position.

To change the angle of the fan blades, take the following steps:

**A.** Remove the grill **①** and the fan housing **②**.

**B.** Remove the fan hub and clutch **③** to enable removal of the propeller from the gearbox's axle. We recommend that you place the propeller on a table top to work comfortably.

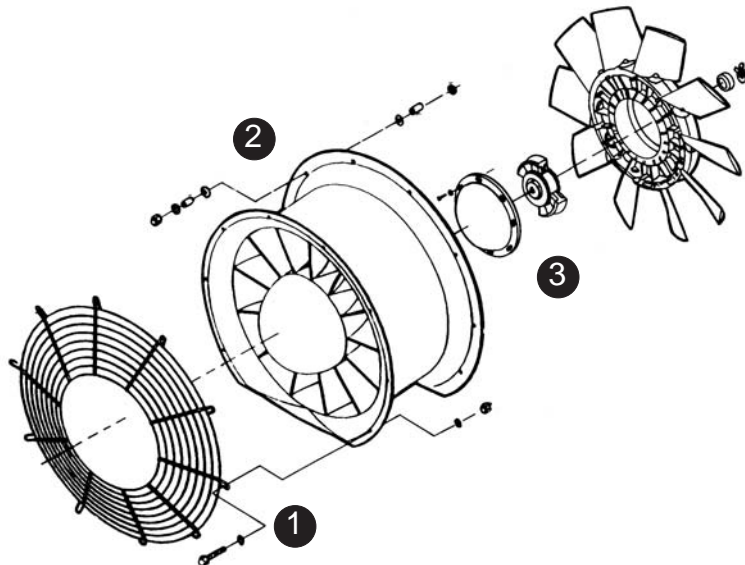

**C.** Unscrew the two screws that join the two support rims located between the blades **④**. In the SF85 blower units it will also be necessary to unscrew the central screws that fix the support rims to the hub casing **⑤**.

Remove the outer support rim and leave the inner one fixed to the hub casing **⑥**, which is held in place by various roll pins **⑦** located at its rear.

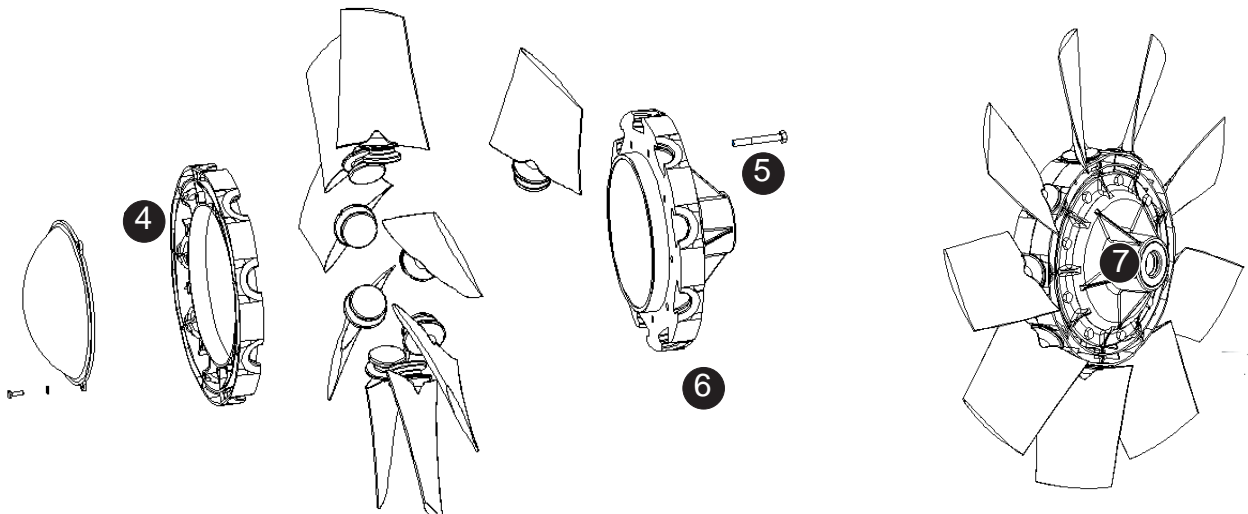

## Axial blower units

**D.** The inner part of the support rims and the fan blade neck have three grooves (8) with which the angle of the blades is adjusted.

The grooves on the fan blade are designated P1, P2 & P3,  
The grooves on the support rims are designated C1, C2 & C3.

For the correct alignment of the fan blade angles in the support rims of the fan, there is one round key that fits into the grooves.

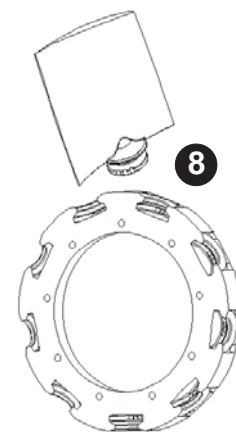

**E.** For the first position (35°) P1 must align with C1, in other words the first groove on the fan blade with the first groove on the support rim (9).

For the second position (40°, standard factory setting) P2 must align with C2, in other words the middle groove on the fan blade and the support rim (10).

For the third position (45°) P3 must align with C3, in other words the third groove on the fan blade and the third groove on the support rim (11).

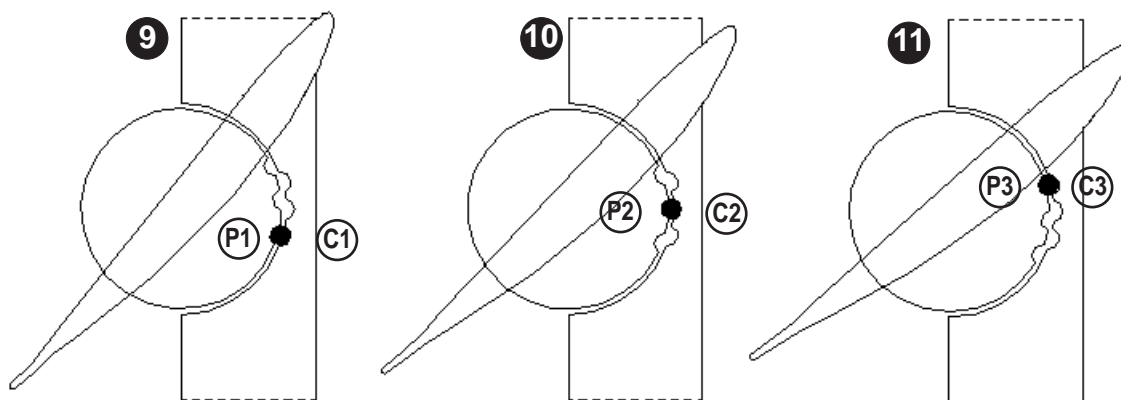

**Always align the grooves  
P1-C1, P2-C2, P3-C3**

IF P3-C2 or P2-C1 ARE ALIGNED BY MISTAKE  
THE FAN BLADE WILL HAVE TOO GREAT AN  
ANGLE WITH THE CONSEQUENT RISK OF  
BURNING THE FAN CLUTCH.

Consult your nearest dealer about modifications  
to the fan blade angles.

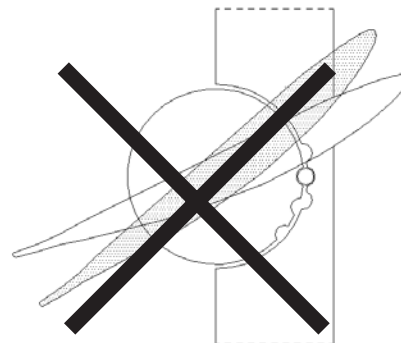



## Axial blower units



### Air outlet width adjustment

Depending on the wind conditions, crop growth stage, leaf size, forward speed of the tractor and the row spacing, it may be necessary to alter the width of the air spout. The width of the fan housing of every fan that leaves the factory is set in the middle position.

Field trials have shown that the best penetration and treatment efficiency is achieved when the droplets reach the outer leaves of the tree at a speed of between 18 and 27 mph (8 and 12 m/s).

As a guide, here are three different cases :

#### Minimum separation

- Windy conditions.
- Small trees.
- Low leaf density.
- Row spacing greater than 20 ft. (6 meters.)

#### Medium separation

- Calm or gentle breeze.
- Medium-sized trees.
- High leaf density.
- Row spacing equal to or less than 20 ft. (6 meters.)

#### Maximum separation

- Calm conditions.
- Large trees.
- Very high leaf density.
- Row spacing less than 20 ft. (6 meters.)

To alter the width of the fan housing carry out the following steps:

**A.** Undo the eight nuts (1) that fix the fan housing (2), remove the fan housing and the safety grill (3).

**B.** Place the 15 mm spacers on the inner or outer part of the fan housing. In the case of there being two spacers together, they should be placed on the side of the cone (4).

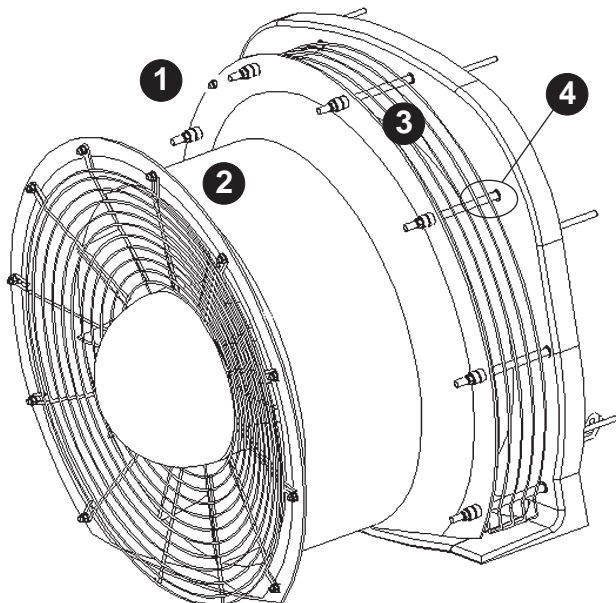

A (mm)	SF45	SF65	SF85
Minimum	160	160	175
Middle STANDARD	175	175	190
Maximum	190	190	205

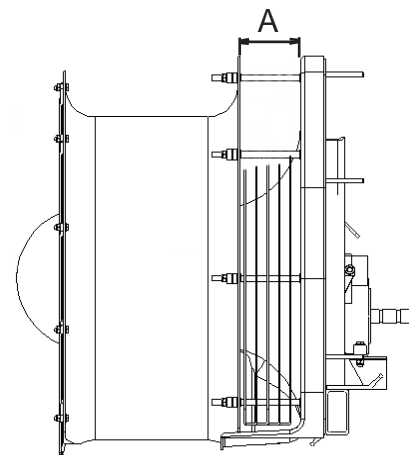

## Axial blower units



### Gearbox oil change



Please respect  
the environment.  
**RECYCLE THE OIL**

The blower unit's gearbox is one of the mechanical elements that is put under the greatest strain.

During the spraying season, the gearbox oil level should be checked regularly and changed at the recommended intervals (see maintenance section).

1. Level indicator
2. Oil fill
3. Oil drain

Unit: SF45 & SF65

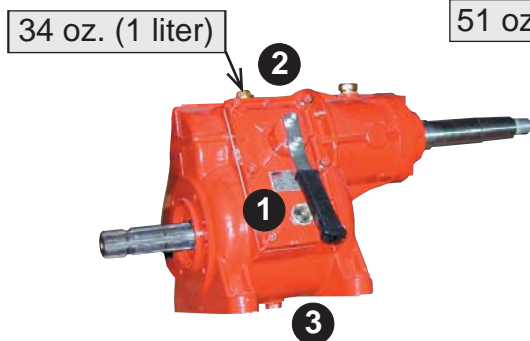

Unit: SF85

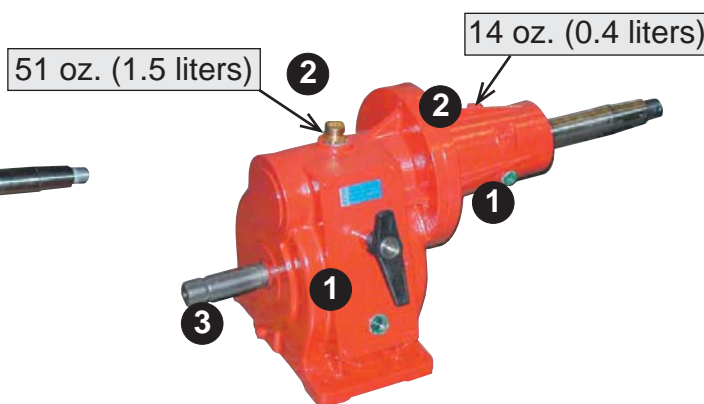

The oil fill is at the top of the mechanism, behind the tank.

**SAE-20/50 MULTIGRADE** or **SAE-90** oil should be used in areas with high temperatures.

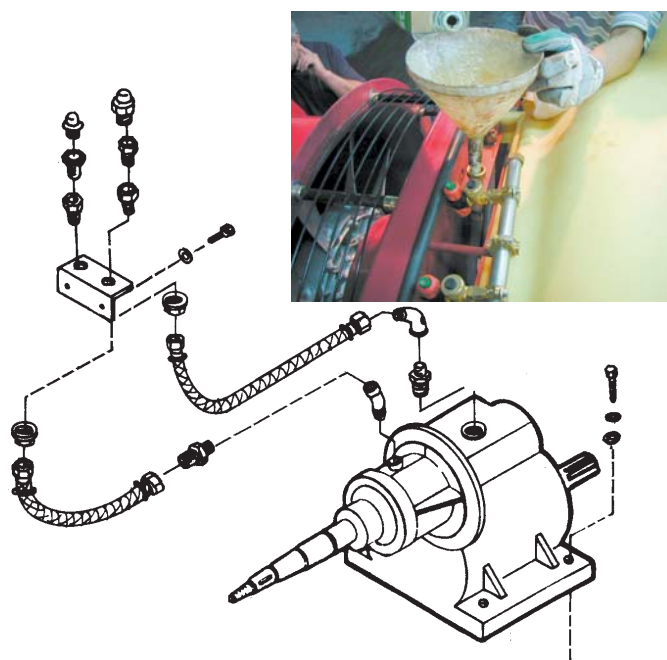
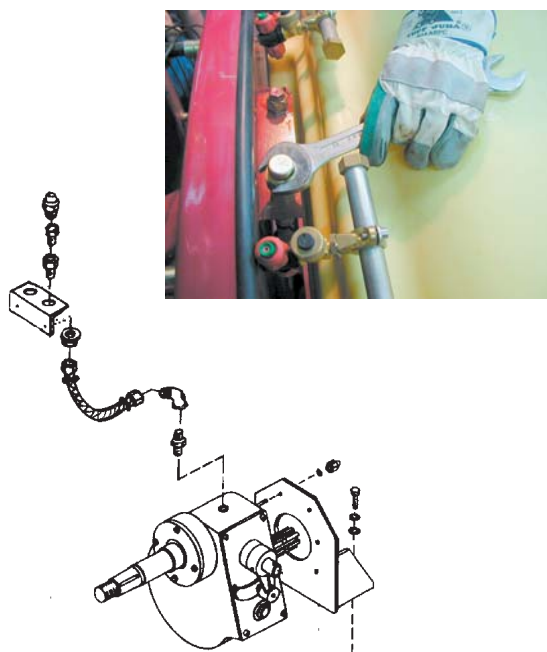



## Axial blower units

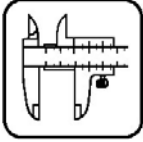

### UNIT SF45 : Air flow and power consumption



**40° (position 2)** For tractors of more than 50 hp (35 kW).

Standard factory assembly. This position gives the most efficient relationship between diesel consumption and air volume rate.

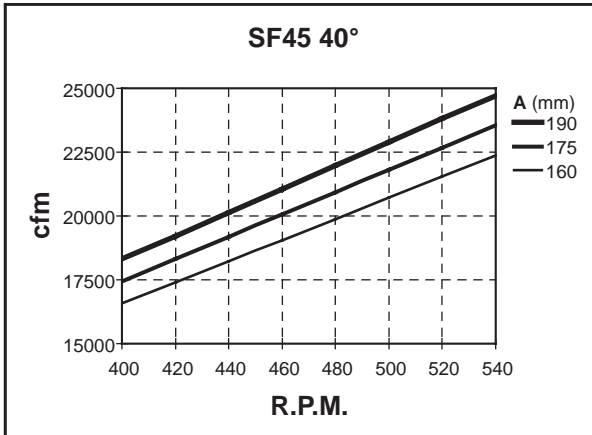

- In low gear reduce the volume rate values by 15%

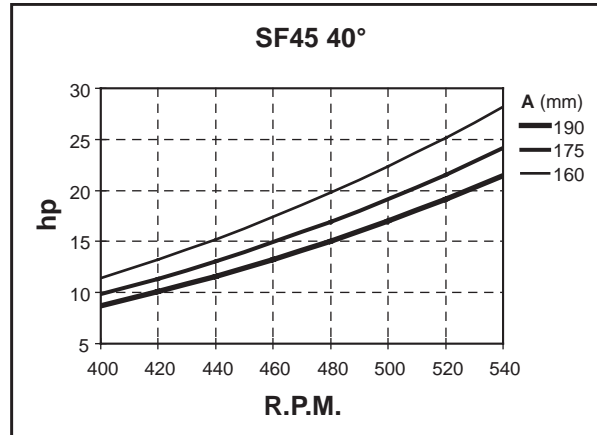

- In low gear reduce the power consumption values by 45%



**45° (position 3)** For tractors of more than 60 hp (45 kW).

Recommended for medium-sized trees or working speeds of more than 3 mph (5 km/h) on small trees or four-sided treatment of vineyards.

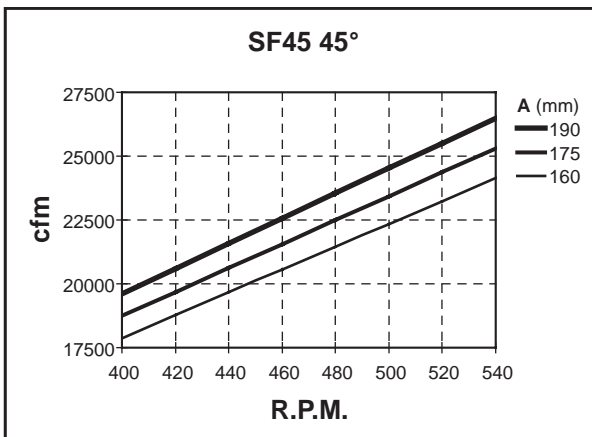

- In low gear reduce the volume rate values by 20%

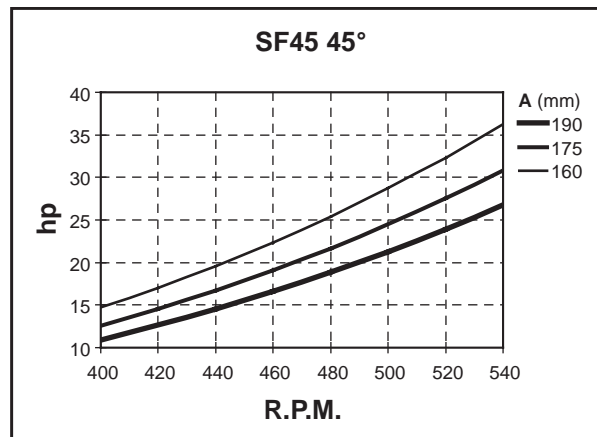

- In low gear reduce the power consumption values by 40%



## Axial blower units

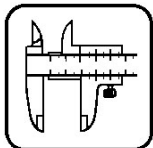

### UNIT SF65 : Air flow and power consumption



**40° (position 2)** For tractors of more than 70 hp (50 kW).  
Standard factory assembly. This position gives the most efficient relationship between diesel consumption and air volume rate.

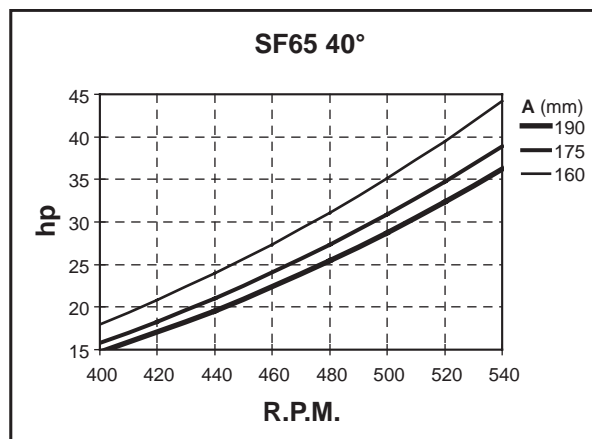
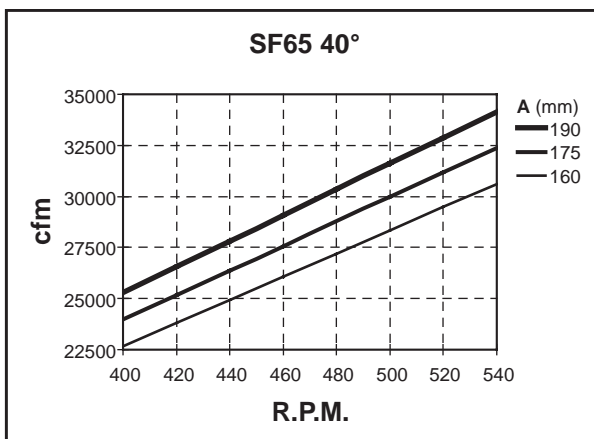

- In low gear reduce the volume rate values by 15%

- In low gear reduce the power consumption values by 45%



**45° (position 3)** For tractors of more than 75 hp (55 kW).  
Recommended for large trees or for working speeds of more than 3 mph (5 Km/h) on medium-sized trees.

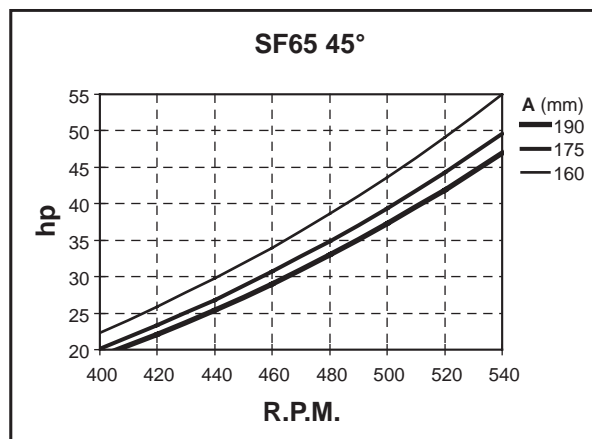
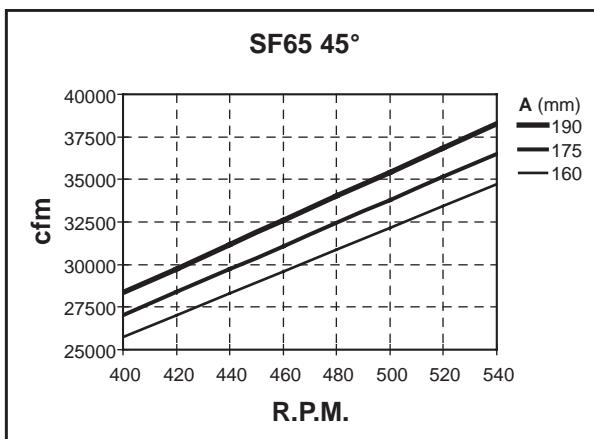

- In low gear reduce the volume rate values by 20%

- In low gear reduce the power consumption values by 40%



## Axial blower units

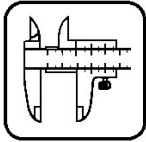

### UNIT SF85 : Air flow and power consumption



#### 40° (position 2) For tractors of more than 80 hp (60 kW).

Standard factory assembly. This position gives the most efficient relationship between diesel consumption and air volume rate.

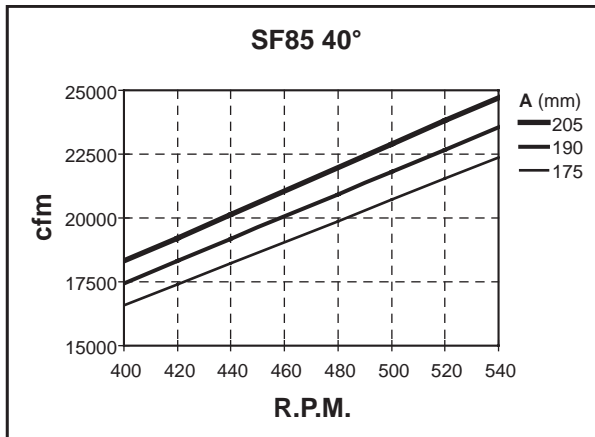

- In low gear reduce the volume rate values by 15%

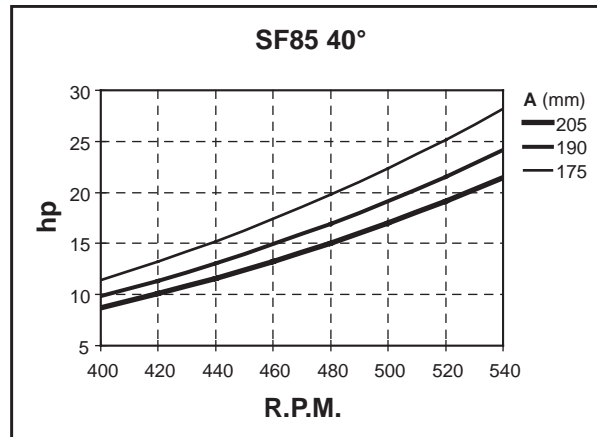

- In low gear reduce the power consumption values by 45%



#### 45° (position 3) For tractors of more than 90 hp (65 kW).

Recommended for very large trees or working speeds of more than 3 mph (6 km/h) on medium-sized to large trees.

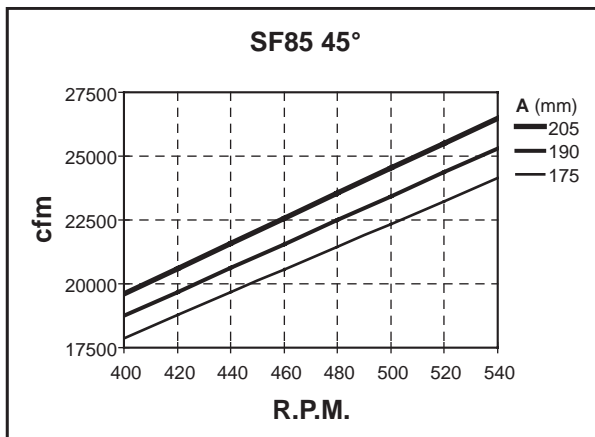

- In low gear reduce the volume rate values by 20%

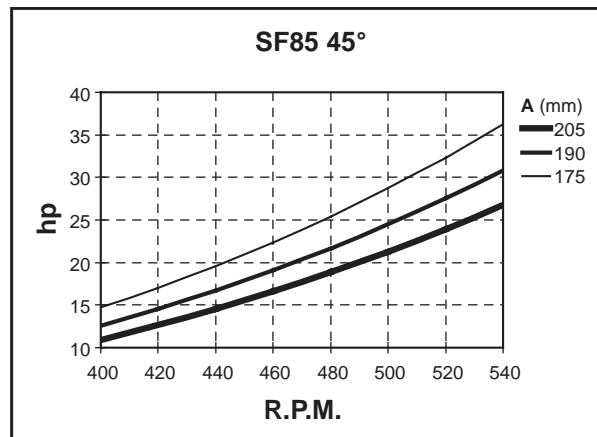

- In low gear reduce the power consumption values by 40%

## Maintenance



### Lubrication

#### P.T.O. shaft

The universal joints and bearings must be lubricated with grease. At points **(A)** this should be done after every **8 working hours**, and the tubes and axles **(B)** every **20 hours**.

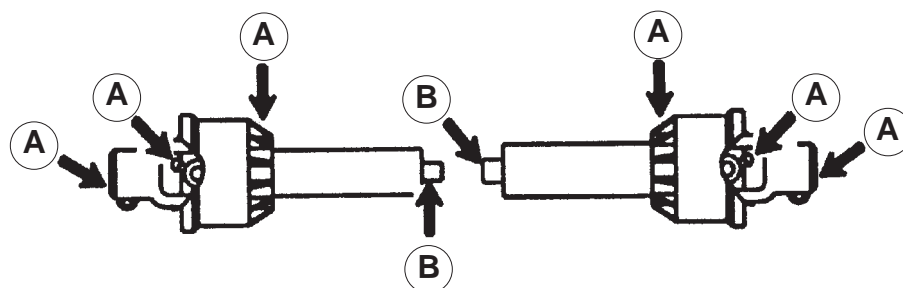

**NOTE.** In all the HARDI® MERCURY models, the P.T.O. shaft that connects the pump to the fan must also be greased.

#### Diaphragm pump

Grease the pump every **50 working hours** or once a month, through the grease nipple situated on the crankshaft axle. The **grease** goes along the grooves in the crankshaft to reach the crankcase where it is distributed around bearings, etc.

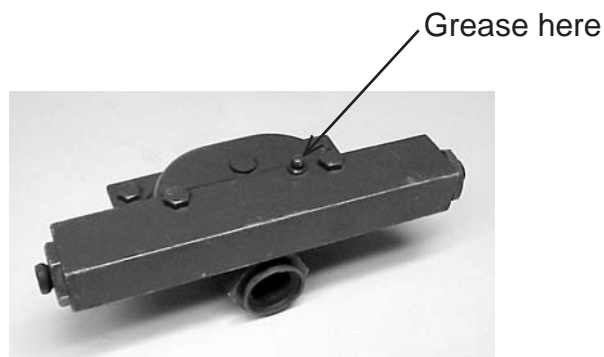
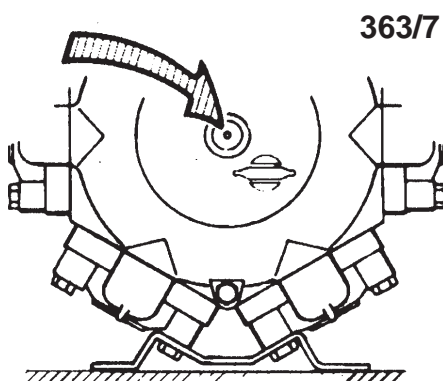

#### Hydraulically controlled section valves

Each hydraulically controlled section valve should be greased every **250 working hours** or once a year, or after cleaning the sprayer.

## Maintenance

### Drawbar

The **swivel drawbar** ① has a grease nipple **E** on its upper surface.

To avoid the wear and seizing up of the drawbar's rotating parts keep them greased at all times.

On the underside of the drawbar, the nut that holds the swivel head in place must also be greased.

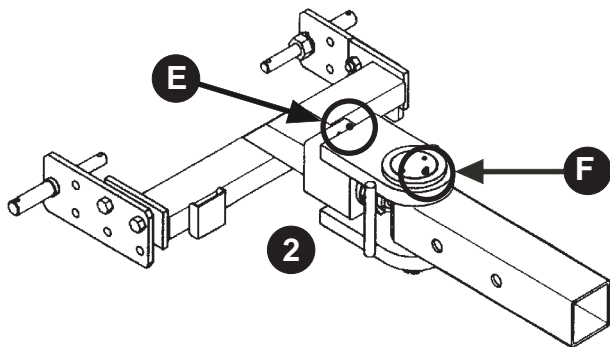
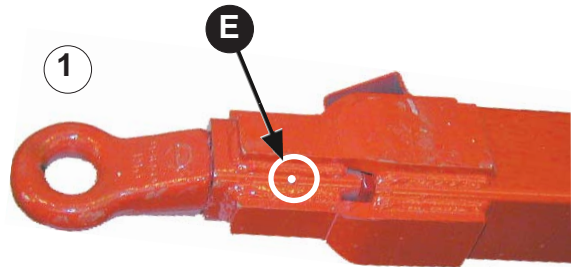

The **turnable hitch drawbar** ② has two grease nipples, **E** and **F**.

These parts must be greased at least **once a year**.

### Axles

The hub is the part of the axle that must be greased. Remove hub cap ③ and grease the inside of the rotating head. Grease at least **once a year**.

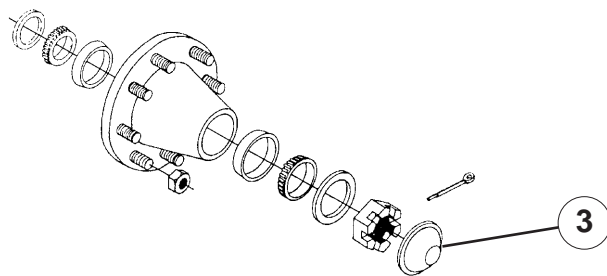

### Filters and fittings

Whenever dismantling any **filter** or hose pipe take care not to pinch the o-rings fitted to them. When replacing the pipe fitting, smear the **o-ring** with **oil** or **grease** so that it falls easily into place in its groove.

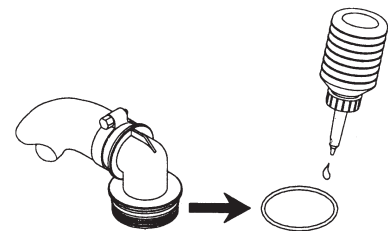

## Maintenance



### Diaphragm pumps

The method of replacing the diaphragms is very simple:

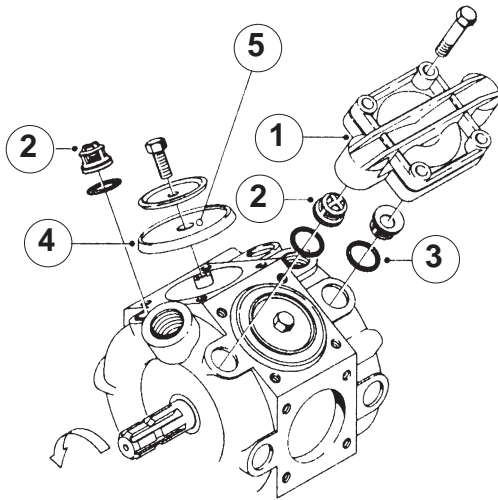

#### Pump 363

- 1 Dismantle the crankcases (1).
- 2 Remove the valves (2) and o-rings (3).
- 3 Remove the diaphragms.
- 4 Remember to place the diaphragms (4) with piece number (5) upwards.
- 5 Reassemble the pump placing the valves in the correct position.



**WARNING.** Bear in mind that there are two different types of valves on the upper crankcases which must be replaced in the same position.



### Nozzles

For cleaning or replacement of the nozzles a spanner should be used to undo the nut (2). Remove the nozzle and clean it with air, water or a toothbrush.

Never use a piece of wire or a needle as this could cause irreparable damage to the nozzle.

If any of the nozzles leak on closing the sector the non-drip diaphragm should be replaced (1).

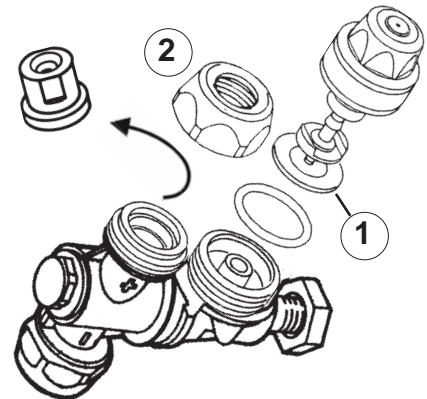



## Maintenance



### Maintenance intervals

#### Every **10 working hours.**

- 1 Clean the suction filter.
- 2 Clean the pressure filters.
- 3 Check the nozzles.
- 4 Check for leaks in the fluid circuit.
- 5 Check for air intake into the suction.
- 6 Check the nuts and tighten if necessary.

#### Every **50 working hours.**

- 1 Carry out the aforementioned tasks.
- 2 Check the wheel nuts and tighten if necessary.
- 3 Check the P.T.O. shaft.
- 4 Check the tire pressure.
- 5 Grease the diaphragm pump.

#### Every **100 working hours.**

- 1 Carry out the aforementioned tasks.
- 2 Check and grease the drawbar.

#### Every **250 working hours.**

- 1 Carry out the aforementioned tasks.
- 2 Check the wheel hubs.
- 3 Check all the hoses.
- 4 Change the gearbox oil.
- 5 Grease hydraulic section valves.

#### Every **1000 working hours.**

- 1 Carry out the aforementioned tasks.
- 2 Service all the hubs.
- 3 Service the transmission.
- 4 Service the pump.
- 5 Service the gearbox.
- 6 Check the pressure gauge.
- 7 Service the clutch and fan.
- 8 Change the wheels.



---

## CLEANING - Basic concepts

---



### Cleaning procedures

#### The chemical product

Read the chemical product's label and those of the detergents and deactivating agents. Take note of any special instructions regarding protective clothing, deactivating agents, etc.

#### Legislation

Be familiar with local legislation regarding disposal of residues, mandatory decontamination methods, etc. If in doubt, consult the appropriate agricultural department in your area.

#### Cleaning and the soakaway

The residues can be disposed of on a special soakaway, not used for crop cultivation. Seepage or runoff of residue into watercourses, wells, springs, pools, etc must be avoided. The washings must not be disposed of in sewers.

#### The sprayer

Cleaning starts with calibration, as a well calibrated sprayer will ensure the minimum amount of remaining spray liquid.

The sprayer should be cleaned immediately after use, thereby leaving it ready for the next application while avoiding contact with mixed chemical products. This also prolongs the life of the components.

If it is necessary to leave spray liquid in the tank for a short period of time, unauthorized persons and animals must not have access to the sprayer.

If the product applied is corrosive, it is recommended to coat all metal parts of the machine before and after use with a suitable rust inhibitor.



#### REMEMBER.

1. Clean sprayers are safe sprayers.
2. A clean sprayer is always ready for action.
3. Clean sprayers are not damaged by pesticides and their solvents.



---

## CLEANING - Basic concepts

---



### Cleaning the sprayer

1. Dilute the remaining spray liquid in the tank with at least 10 parts of water and spray the liquid on trees that have already been treated. It is advisable to increase the forward speed (double it if possible) and reduce the pressure.
2. Select and use the appropriate protective clothing, such as rubber gloves, face mask, wellington boots, etc. Select an appropriate detergent for cleaning and a deactivating agent if necessary.
3. Wash the outside of the tractor and sprayer with detergent.
4. Clean the suction and pressure filters. Take care not to damage the mesh. Replace.
5. With the pump running, rinse the inside of the tank, remembering the tank roof too. Rinse and operate all the components that have been in contact with the chemical product. Before opening the nozzles make sure that the machine is on crops or the soakaway.
6. After all the liquid has been emptied out, stop the pump and fill at least 1/5 of the tank with clean water, and add detergent and/or deactivating agent, for example washing soda or triple ammonia.
7. Start the pump and operate all controls so that the liquid is distributed to all the components. Leave the nozzles until last.
8. Drain the tank and let the pump run dry. Stop the pump as soon as it becomes empty. Rinse the inside of the tank.
9. Fit the filters and nozzles and store the sprayer. The solvents used in the chemical products react very strongly. Store the sprayer with the tank lid removed.

Check periodically for corrosion and react accordingly.



### Unforeseen interruptions

If an application must be interrupted unexpectedly, for example because of bad weather, and there is still liquid remaining in the tank it is advisable to flush the pump, operating unit and tubes.

Close the nozzles and stop the PTO. Close the suction filter valve and open the filter. Start the pump and immediately run clean water through the suction hose that leads to the pump and open the nozzles. Continue until clean water is coming through the nozzles. Stop the pump and reassemble the suction filter.



---

## Off-season storage

---



### Off-season storage

When the spraying season is over, you should devote some extra time to the sprayer. If chemical residues are left over in the sprayer for long periods, it can reduce the life of the individual components. To preserve the sprayer and protect the components, carry out the following off-season storage program:

1. Clean the sprayer completely - inside and outside - as described under "Cleaning the sprayer". Make sure that all valves, hoses and auxiliary equipment have been cleaned with detergent and flushed with clean water afterwards, so no chemical residues are left in the sprayer.
2. Renew any damaged seals and repair any leaks.
3. Empty the sprayer completely and let the pump work for a few minutes. Operate all valves and handles to drain as much water out of the spraying circuit as possible. Let the pump run until air is coming out of all nozzles.
4. Pour appr. 13 gal. (50 liters) anti-freeze mixture consisting of 1/3 automotive anti-freeze and 2/3 water into the tank.
5. Engage the pump and operate all valves and functions on the MANIFOLD system, etc. allowing the anti-freeze mixture to be distributed around the entire circuit. Activate the hydraulically controlled blower section valves so the anti-freeze is sprayed through the nozzles as well. The anti-freeze will also prevent O-rings, seals, diaphragms, etc. from drying out.
6. When the sprayer is dry, remove rust from any scratches or damages in the paint and touch up the paint.
7. Lubricate all lubricating points according to the lubricating scheme - regardless of intervals stated.
8. Remove the glycerine-filled pressure gauges and store them in a vertical position in frost free conditions.
9. Apply a thin layer of anti-corrosive oil (e.g. SHELL ENSIS FLUID, CASTROL RUSTILLO or similar) on all metal parts. Avoid oil on rubber parts, hoses and tires.
10. Relieve pressure from all hydraulic functions.
12. Wipe hydraulic snap-couplers clean and fit the dust caps.
13. Jack up the axle and place wooden blocks under the wheels to prevent moisture damage and deformation of the tires. Tire black can be applied to the tire side walls to preserve the rubber.
14. To protect against dust, the sprayer can be covered by a tarpaulin. Ensure ventilation to prevent condensation.



---

## Off-season storage

---



### Preparation after off-season storage

After a storage period, the sprayer should be prepared for the next season the following way:

1. Remove the cover. (If fitted)
2. Remove the blocks from under the wheels and adjust the tire pressure.
3. Fit the pressure gauges again. Seal with Teflon tape.
4. Connect the sprayer to the tractor, including hydraulics.
5. Check all hydraulic functions.
6. Empty the tank of remaining anti-freeze.
7. Rinse the entire liquid circuit on the sprayer with clean water.
8. Fill with clean water and check all functions.

## Troubleshooting



### Operational problems

If all of the maintenance operations have been carried out, you should not have any problems with the sprayer. If there is a breakdown, it is nearly always due to the following factors:

- a. Small holes in the pump's suction tube reduce or completely nullify its capacity for suction.
- b. If the suction filter is clogged up, suction will be made more difficult or impossible and the pump will not work correctly.
- c. If the pressure filters are clogged up, pressure in the pressure gauge will rise but not so in the nozzles.
- d. Dirt in the valves may impede their complete closure. This will also worsen the pump's performance.
- e. If the pump has been badly assembled, especially the diaphragm lids (diaphragm pump) or the suction chamber (piston pump), air will be sucked in and the pump's capacity will be reduced or nullified.
- f. If some of the electrical components are dirty they will not make good contact.

Therefore always check that:

- 1 The suction, pressure and nozzle filters are clean.
- 2 The hoses are well-fitted and have no splits or cracks.
- 3 The joints and o-rings are in good condition.
- 4 The pressure gauge is in good condition. The correct dosage depends on its accuracy.
- 5 The operating unit is in good working order. Test it with clean water.
- 6 The electrical components are clean.



### Troubleshooting

To help solve any problems consult this table before taking the machine to a repair workshop. If the problem is not in this table consult your nearest dealer.

Fault	Cause	Solution
No liquid comes out of the nozzles.	Air entering suction.	Check that the suction O-ring seals properly.
		Check the main suction hose and its connections.
		Make sure that the valve bodies and suction chamber are not loose.



## Troubleshooting

Fault	Cause	Solution
No liquid comes out of the nozzles.	Air in the system.	Fill the suction hose with the water for initial filling.
	Suction or pressure filters obstructed.	Clean the filters.
		Check that the suction fitting is not obstructed or too near the bottom of the tank.
Lack of pressure.	Incorrect assembly.	The agitation restrictor is not fitted.
		The safety valve's spring does not close properly.
		The suction fitting inside the tank is obstructed.
	Pump valve blocked or worn.	Check for possible blockage or wear.
	Pressure gauge defective or dirty.	Check for obstruction of pressure gauge inlet.
Pressure drop.	Blocked filters.	Clean all filters. Fill with clean water and start up.
		If powdered product is being used, check that the agitation is on.
	Worn nozzles.	Check the flow through every one and replace those that exceed it by 10%.
	Air suction when emptying the tank.	Too much agitation. Disconnect the agitator to empty the tank.
Pressure raise.	The pressure filters are starting to block.	Clean all filters.
	Agitation restrictor.	Check for blockage by opening and closing agitation.
Foam production.	Air is entering the system.	Check for loose nuts/fittings/O-rings in the suction system.
	Excessive agitation	Close the agitation. Reduce the tractor's r.p.m.
		Use anti-foaming agent.

## Troubleshooting

Fault	Cause	Solution
Liquid is leaking from the bottom of the pump.	Damaged diaphragms or plungers.	See maintenance section.
Excessive noise or vibrations in the blower unit.	The fan has lost it's counter-weight.	Take the fan to be re-balanced. Consult your dealer.
	The blower unit's nuts are loose.	Tighten the nuts.
	The clutch plates are broken or worn.	Change the fan clutch.
Vibrations or noises in the gearbox.	The gear is not properly engaged.	Put the gear lever in the correct position.
	Worn tooth-wheels.	Replace the tooth-wheels.
	Oil level below minimum.	Fill to the indicated level.



## Technical data

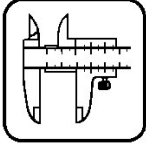

### Dimensions

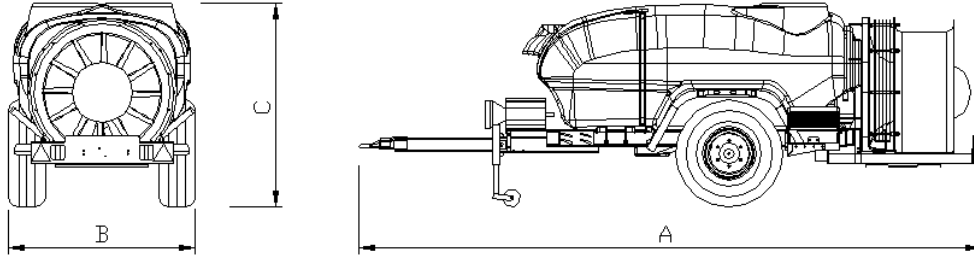

Dimensions	MERCURY 600
A	13ft. 6in. (4138mm)
B	4ft. 6in. (1400mm)
C	4ft. 9in. (1500mm)

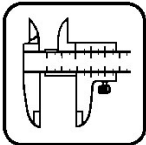

### Weights

MERCURY 600			
Load	Axle loading	Drawbar loading	Total weight
Empty	1865 lbs. (846 kg)	175 lbs. (80 kg)	2040 lbs. (926 kg)
Full	6990 lbs. (3171 kg)	890 lbs. (405 kg)	7885 lbs. (3576 kg)

All the weights are approximate.

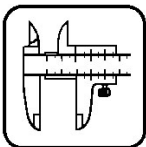

### Wheels

WHEELS (Tires & Rims)		
Model	Standard	Optional
Mercury 600	12.5L x15"	14Lx16.1" (12 ply)

## Technical data

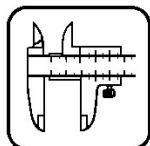

### Diaphragms pumps

Model 363/7

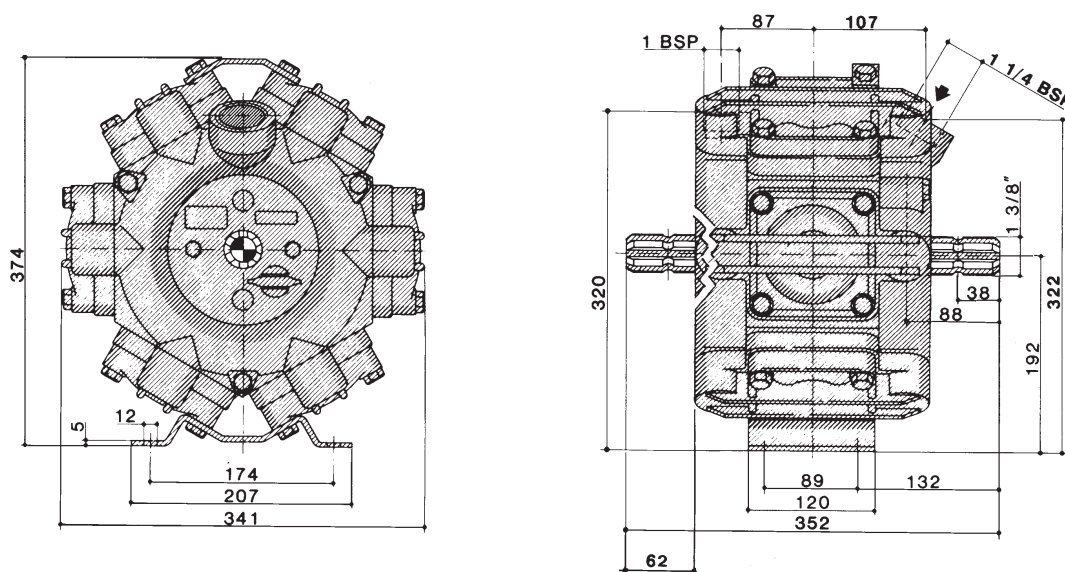

363/7	r/min											
	300		400		500		540		600		700	
PSI	gpm	Hp	gpm	Hp	gpm	Hp	gpm	Hp	gpm	Hp	gpm	Hp
0	20.6	1.2	27.5	1.6	34.6	2.1	37.0	2.1	41.2	2.5	48.3	3.0
29	20.1	1.3	26.9	1.7	33.8	2.3	35.9	2.4	40.1	2.7	46.7	3.1
58	19.5	1.7	25.9	2.0	33.0	2.5	35.1	2.8	38.8	3.2	44.9	3.8
88	19.3	1.9	25.6	2.4	31.9	3.1	34.3	3.4	38.0	3.9	44.1	4.7
147	18.7	2.4	25.1	3.2	30.9	4.2	33.5	4.6	37.2	5.1	43.3	6.2
220	18.5	3.2	24.3	4.3	30.4	5.2	32.7	5.9	36.2	6.7	42.5	7.9
294	18.0	3.9	23.8	5.2	29.8	6.4	32.2	7.2	35.6	7.9	41.7	9.4

Maximum pressure: 294 PSI (20 bar)

Weight: 116 lbs. (52.6 kg.)

Normal working revolutions: 540 r/min



## General specifications

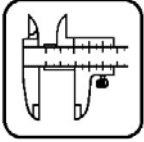

### General specifications

#### Filters

Suction filter: 50 mesh: 0.012" (0.3 mm)

Pressure filter: 50 mesh: 0.012" (0.3 mm)

#### Working temperature and pressure

Temperature: 36°F to 104°F (2°C to 40°C)

Maximum pressure inside the manifold:  
290 psi (20 bar)

Maximum pressure in the suction manifold:  
102 psi (7 bar)

#### Materials

Tanks: UV resistant polyethylene

Hoses: PVC or rubber

Valves: PA with carbon fiber

Fittings: PA

Fan: Aluminium

#### Recycling

When the sprayer has reached the end of its useful working life, it must be thoroughly cleaned.

Many parts can be recycled.

The tank is 100% recyclable at a plastic recycling plant.

The hoses and synthetic fittings can be incinerated at an authorized disposal plant.

The aluminium parts of the fan can be taken to an aluminium recycling plant.

The metal parts can be taken to a scrapyard.

Always follow local legislation regarding disposal.



## General specifications



### Pictograms



Description



Powder mixer

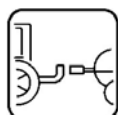

Connecting the sprayer



Clean water tank

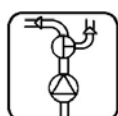

Fluid circuit

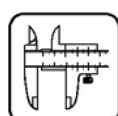

Specifications

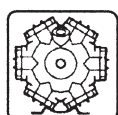

Diaphragm pumps



Off-season storage



Operating units



Operational problems



Filters



Maintenance

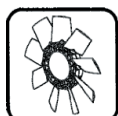

Blower unit



Cleaning



Main tank



Warning



Nozzles



Lubrication

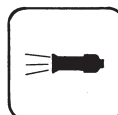

Agitation



---

## WARRANTY POLICY AND CONDITIONS

---

HARDI® INC. , 1500 West 76th Street, Davenport, Iowa, USA; 5646 W. Barstow, Fresno, California, USA; and 290 Sovereign Road, London, Ontario, Canada hereinafter called "HARDI®", offers the following limited warranty in accordance with the provisions below to each original retail purchaser of HARDI® new equipment of its own manufacturer, from an authorized HARDI® dealer, that such equipment is at the time of delivery to such purchaser, free from defects in material and workmanship and that such equipment will be warranted for a period of one year from the date of delivery to the end user providing the machine is used and serviced in accordance with the recommendations in the Operator's Manual and is operated under normal farm conditions.

1. This limited warranty is subject to the following exceptions:
  - a) Parts of the machine not manufactured by HARDI®, (i.e. engines, tires, tubes, electronic controls, and other components or trade accessories, etc.) are not covered by this warranty but are subject to the warranty of the original manufacturer. Any claim falling into this category will be taken up with the manufacturer concerned.
  - b) This warranty will be withdrawn if any equipment has been used for purposes other than for which it was intended or if it has been misused, neglected, or damaged by accident, let out on hire or furnished by a rental agency. Nor can claims be accepted if parts other than those manufactured by HARDI® have been incorporated in any of our equipment. Further, HARDI® shall not be responsible for damage in transit or handling by any common carrier and under no circumstances within or without the warranty period will HARDI® be liable for damages of loss of use, or damages resulting from delay or any consequential damage.
2. We cannot be held responsible for loss of livestock, loss of crops, loss because of delays in harvesting or any expense or loss incurred for labor, supplies, substitute machinery, rental for any other reason, or for injuries either to the owner or to a third party, nor can we be called upon to be responsible for labor charges, other than originally agreed, incurred in the removal or replacement of components.
3. The customer will be responsible for and bear the costs of:
  - a) Normal maintenance such as greasing, maintenance of oil levels, minor adjustments, etc.
  - b) Transportation of any HARDI® product to and from where the warranty work is performed.
  - c) Dealer travel time to and from the machine or to deliver and return the machine from the service workshop for repair.
  - d) Dealer traveling costs.
4. Parts defined as normal wearing items, (i.e. tires and V-belts) are not in any way covered under this warranty.
5. This warranty will not apply to any product which is altered or modified without the express written permission of HARDI® and/or repaired by anyone other than an Authorized Service Dealer.
6. Warranty is dependent upon the strict observance by the purchaser of the following provisions:
  - a) That this warranty may not be assigned or transferred to anyone.
  - b) That the Warranty Registration Certificate has been correctly completed by dealer and purchaser with their names and addresses, dated, signed and returned to the appropriate address as given on the Warranty Registration Certificate.
  - c) That all safety instructions in the operator's manual shall be followed and all safety guards regularly inspected and replaced where necessary.
7. No warranty is given on second-hand products and none is to be implied.

---

## WARRANTY POLICY AND CONDITIONS

---

8. Subject to the following terms and conditions, HARDI® extends the warranty on polyethylene tanks on mist-blower sprayers with axial or centrifugal fans (excluding fittings, lids and gaskets) to TEN YEARS. To qualify for this extended warranty, the tank must be drained and flushed with fresh water after each day of use. HARDI®'s liability is limited to replacement of the tank, FOB our plants in Davenport, IA, USA; Fresno, CA, USA, and London, Ontario, Canada at no cost to the purchaser during the first ten years. This ten year extended warranty is subject, in each instance, to the tank being inspected and approved for replacement or repair by HARDI® personnel before HARDI® will accept any liability hereunder.
9. Subject to the following terms, conditions, contributions, HARDI® extends the warranty on HARDI® diaphragm pumps (excluding wearing parts such as diaphragms, valves, etc.) to FIVE YEARS. To qualify for this extended warranty, the pump must be drained and flushed with fresh water after each day of use. HARDI®'s liability is limited to replacement of defective parts, FOB our plants in Davenport, IA, USA; Fresno, CA, USA, and London, Ontario, Canada at no cost to the purchaser during the first twelve months after date of purchase, at 20% of the then current retail price during the second year ; at 40% during the third year ; at 60% during the fourth year ; and at 80% during the fifth year. This five year extended warranty is subject, in each instance, to the pump being inspected and approved for replacement or repair by HARDI® personnel before HARDI® will accept any liability hereunder.
10. HARDI® reserves the right to incorporate any change in design in its products without obligation to make such changes on units previously manufactured.
11. The judgement of HARDI® in all cases of claims under this warranty shall be final and conclusive and the purchaser agrees to accept its decisions on all questions as to defect and to the exchange of any part or parts.
12. No employee or representative is authorized to change this warranty in any way or grant any other warranty unless such change is made in writing and signed by an officer of HARDI® at its head office.
13. Any warranty work performed which will exceed \$400.00 MUST be approved IN ADVANCE by the Service Manager.
14. Any pump replacement must be approved in advance by the Service Manager.
15. Claims under this policy must be filled with HARDI® within thirty (30) days of work performed or warranty shall be void.
16. Parts requested must be returned prepaid within thirty (30) days for warranty settlement.
17. Warranty claims must be COMPLETELY filled out properly or will be returned.

### DISCLAIMER OF FURTHER WARRANTY

THERE ARE NO WARRANTIES, EXPRESSED OR IMPLIED, EXCEPT AS SET FORTH ABOVE. THERE ARE NO WARRANTIES WHICH EXTEND BEYOND THE DESCRIPTION OF THE PRODUCT CONTAINED HEREIN. IN NO EVENT SHALL THE COMPANY BE LIABLE FOR INDIRECT, SPECIAL OR CONSEQUENTIAL DAMAGES (SUCH AS LOSS OF ANTICIPATED PROFITS) IN CONNECTION WITH THE RETAIL PURCHASER'S USE OF THE PRODUCT.

