

# COMMANDER *plus* TWIN FORCE

## Instruction book

670747-GB-2000/01

**We congratulate you for choosing a HARDI plant protection product. The reliability and efficiency of this product depend upon your care. The first step is to carefully read and pay attention to this instruction book. It contains essential information for the efficient use and long life of this quality product.**



**As the instruction book covers all COMMANDER *plus* models with HAY boom or HAZ boom, please pay attention to the paragraphs dealing with precisely your model.**

**This book is to be read in conjunction with the “Spray Technique” book.**

**More information about the COMMANDER *plus* can be found on the product’s own website at: <http://www.commander-plus.com>**

Illustrations, technical information and data in this book are to the best of our belief correct at the time of printing. As it is HARDI INTERNATIONAL A/S policy permanently to improve our products, we reserve the right to make changes in design, features, accessories, specifications and maintenance instructions at any time and without notice. HARDI INTERNATIONAL A/S is without any obligation in relation to implements purchased before or after such changes.

HARDI INTERNATIONAL A/S cannot undertake any responsibility for possible omissions or inaccuracies in this publication, although everything possible has been done to make it complete and correct.

As this instruction book covers more models and features or equipment, which are available in certain countries only, please pay attention to paragraphs dealing with precisely your model.

Published and printed by HARDI INTERNATIONAL A/S



# Table of Contents

Declaration of Conformity .....	4
Operator safety .....	5
COMMANDER plus .....	6
Sprayer use .....	8
Unloading the sprayer from the truck .....	8
Before putting the sprayer into operation .....	8
Connecting the sprayer .....	9
Drawbars .....	9
Fixed drawbar .....	10
STEERING drawbar .....	10
SELF TRACK for COMMANDER 2200/2800 .....	10
TRAIL CONTROL .....	10
Transmission shaft .....	11
Operator safety .....	11
Installation of transmission shaft .....	11
Track gauge .....	13
Altering the track gauge .....	13
Adjustment ranges - track width .....	14
Permitted rim positions .....	15
Hydraulic systems .....	16
Tractor Operated Hydraulics .....	16
Direct Acting Hydraulic system .....	16
Load Sensing .....	16
Control boxes and power supply .....	17
Brakes .....	18
Emergency and parking brake (if fitted) .....	18
Hydraulic activated brakes (if fitted) .....	18
Air activated brakes (if fitted) .....	18
Single-line brakes (if fitted) .....	19
Dual-line brakes (if fitted) .....	19
Counter weight (TRACKER models only) .....	20
Transport .....	21
Roadworthiness .....	21
Rear lights (if fitted) .....	21
Transport brackets, height setting .....	21
Transport lock .....	22
Driving Technique .....	23
STEER TRACK and SELF TRACK .....	23
STEER TRACK .....	23
SELF TRACK .....	24
TRAIL CONTROL .....	24
Equipment - Standard and Additional .....	25
Ladder .....	25
Platform .....	25
Tank level indicator .....	25
Large storage Locker (if fitted) .....	25
Small storage Locker (if fitted) .....	25
Front Locker (if fitted) .....	25
Boom and Work lights (if fitted) .....	26
Crop protection Kit (if fitted) .....	27
Mudguards (if fitted) .....	28
Disconnecting the sprayer .....	29
Operating the boom .....	30
The HAY boom .....	30
The HAZ boom .....	30
Air slot angling .....	30
Electrical fan speed adjustment (if fitted) .....	31
Boom suspension sensitivity .....	31
Operating the liquid system .....	32
MANIFOLD SYSTEM .....	32
Use of MANIFOLD valve system .....	32
Electrical operated MANIFOLD valves (if fitted) .....	33
Quick reference .....	33
Filling of water .....	33
Filling of rinsing tank (if fitted) .....	35
Filling of clean water tank .....	36
Adjustment of EVC operating unit .....	36
Adjustment of pressure equalisation .....	36
Operating the control unit while spraying .....	37
Remote pressure gauge (if fitted) .....	37

Filters .....	37
Self-cleaning filter .....	37
Choice of correct restrictor .....	37
Filling of chemicals .....	38
Filling of Liquid chemicals .....	38
Filling of Powder chemicals .....	39
Use of rinsing tank and rinsing nozzles (if fitted) .....	40
Technical Residue .....	41
Draining a residue .....	41
Using the drain valve .....	41
Using the suction quick coupler .....	41
Operation of the drain valves .....	41
Safety precautions .....	42
Personal protection .....	42
Air technique .....	43
Air speed / Air volume .....	43
Blower adjustment .....	43
Angling of air and liquid .....	43
Adjusting the air assistance .....	43
Setting of air speed, rules of thumb .....	44
Angling of air and liquid, rules of thumb .....	44
Water sensitive paper .....	45
Maintenance - rules of thumb .....	49
Cleaning the sprayer .....	49
Cleaning the tank .....	49
Cleaning and maintenance of filters .....	50
Lubrication .....	51
Lubricating points .....	51
Service and Maintenance intervals .....	56
10 hours service .....	56
50 hours service .....	56
100 hours service .....	56
250 hours service .....	56
500 hours service .....	56
1000 hours service or yearly, whichever comes first .....	57
Occasional maintenance .....	57
Off-season storage .....	76
Off-season storage program .....	76
Preparing the sprayer for use after storage .....	76
Fault-finding .....	77
Operational problems .....	77
TRACKER damping system .....	77
Liquid system .....	78
EVC Operating unit .....	79
Hydraulic system (Tractor Operated Hydraulics) .....	79
Hydraulic system (Direct Acting Hydraulic System) .....	80
Hydraulic fan transmission .....	81
Emergency operation of the sprayer .....	82
The boom .....	82
Steering drawbar (if fitted) .....	82
Technical specifications .....	83
Overall dimensions .....	83
Weight .....	83
Pump capacity .....	85
Filters and nozzles .....	86
Temperature and pressure ranges .....	86
Brakes .....	86
Materials and recycling .....	86
Disposal of the sprayer .....	86
Conversion factors, SI to Imperial units .....	86
Electrical connections .....	86
Rear lights .....	86
Electrical connections for EVC operating unit .....	87
Electrical chart (EVC) .....	87
Installation instruction for boom and work light .....	88
Electrical specifications for Boom and Work light .....	89
Boom hydraulic charts .....	90
Subject index .....	xx

# EC Declaration



## Declaration of Conformity

**Manufacturer,**

HARDI INTERNATIONAL A/S  
Helgeshøj Allé 38  
DK 2630 Taastrup  
DENMARK

**Importer,**

declare that the following product;

---

**A.** was manufactured in conformity with the provisions in the COUNCIL DIRECTIVE of 14 June 1989 on mutual approximation of the laws of the Member States on the safety of machines (89/392/EEC as amended by directives 91/368/EEC and 93/368/EEC) with special reference to Annex 1 of the Directive on essential safety and health requirements in relation to the construction and manufacture of machines.

**B.** was manufactured in conformity with the current standards implementing harmonised standards in accordance with Article 5 (2) and other relevant standards.

Taastrup, January 2000

---

Erik Holst  
Managing Director  
HARDI INTERNATIONAL A/S

Adhere extra shipping package labels in the  *Product Identification Certificate.*

# Safety notes

## Operator safety



Watch for this symbol .  
It means **WARNING, CAUTION,**  
**NOTE.** Your safety is involved so be  
alert!

Note the following recommended precautions and safe operating practices.



**Read and understand this instruction book before using the equipment. It is equally important that other operators of this equipment read and understand this book.**



**Local law may demand that the operator be certified to use spray equipment. Adhere to the law.**



**Pressure test with clean water prior to filling with chemicals.**



**Wear protective clothing.**



**Rinse and wash equipment after use and before servicing.**



**Depressurize equipment after use and before servicing.**



**Never service or repair the equipment whilst it is operating.**



**Disconnect electrical power before servicing.**



**Always replace all safety devices or shields immediately after servicing.**



**If an arc welder is used on the equipment or anything connected to the equipment, disconnect power leads before welding. Remove all inflammable or explosive material from the area.**



**Do not eat, drink or smoke whilst spraying or working with contaminated equipment.**



**Wash and change clothes after spraying.**



**Wash tools if they have become contaminated.**



**In case of poisoning, immediately seek medical advice. Remember to identify chemicals used.**



**Keep children away from the equipment.**



**Do not attempt to enter the tank.**



**Do not go under any part of the sprayer unless it is secured. The boom is secure when placed in the transport brackets.**

If any portion of this instruction book remains unclear after reading it, contact your HARDI dealer for further explanation before using the equipment.

# Description

## COMMANDER plus

The COMMANDER plus is divided into three zones: a Clean zone, a Working zone and an Application zone, referring to the level of possible pesticide contamination.

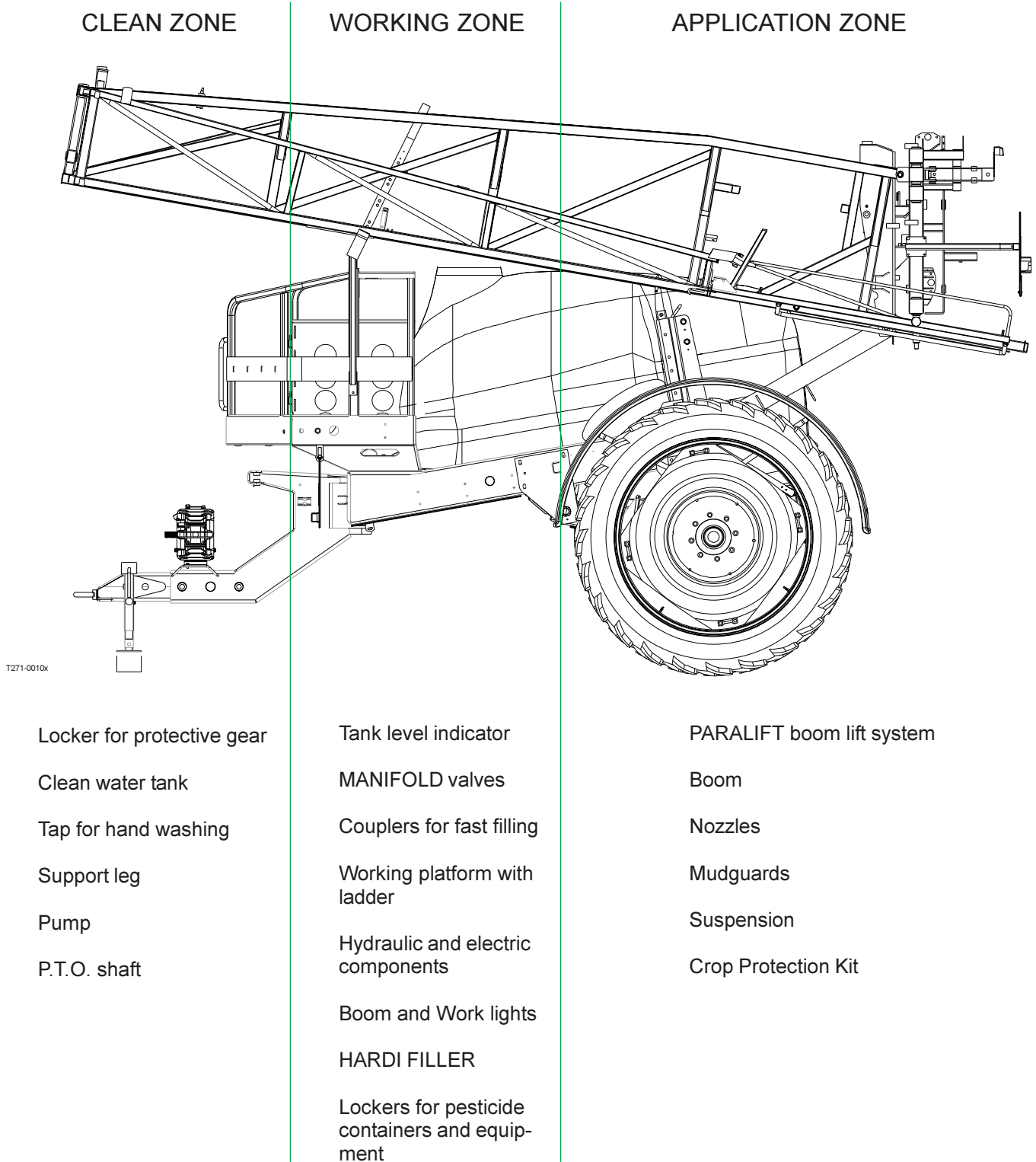

Please note that some of the features are optional equipment

# Description

## Description

### Frame

Strong and compact frame with several options of drawbars and wheel sizes. The frame has a strong chemical and weather resistant electrostatic lacquer coat. Screws, nuts, etc. have been DELTA-MAGNI treated to be resistant to corrosion.

### Tank

UV-resistant Polyethylene in a suitable design with no sharp corners for easy agitation, emptying and cleaning. Nominal contents 2200, 2800, 3200 or 4200 l.

### Pump

Diaphragm pump with 6 diaphragms, model 363 or 463, depending on boom width, with easily accessible valves and diaphragms. Standard = 540 r.p.m. (6 splines)  
Optional = 1000 r.p.m. (21 splines).

### MANIFOLD SYSTEM

All functions of the spray circuits are operated via the centrally situated MANIFOLD valves with colour coded plates and pictorial symbols for easy operation.

### Operating unit

The system is based on EVC - Electrical Valve Control. The on/off is linked to the section valves, which is resulting in a very quick response to on/off.

The operating unit is constructed of modules and is electrically controlled via a remote control box.

The built-in HARDI-MATIC ensures a constant volume per hectare of the liquid (l/ha) at varying forward speed within the same gear when the number of P.T.O. revolutions are between 300-600 r.p.m. (pump 540 r.p.m.) or 650-1100 r.p.m. (pump 1000 r.p.m.).

### Filters

With the self-cleaning filter the impurities that exist in the spray liquid will bypass the filter and be recirculated back to the tank via the return flow. Also suction filter and nozzle filters are standard. In-line pressure filters can be fitted as option.

### Boom

All booms are suspended in a strong, stable parallelogram boom lift.

The HAY/HAZ booms are trapeze/pendulum suspended and fully hydraulically operated, including boom slanting control and air slot angling. HAZ models have Direct Acting Hydraulics (D.A.H.) and individual boom tilt function as well.

The TWIN blowers are driven by a built-in hydrostatic transmission powered via the tractor P.T.O. Blower speed can be adjusted stepwise from the tractor cabin. The HAY/HAZ booms are available in 18, 20, 21, 24, 27

and 28 m working width.

### Identification plates

An identification plate fitted on the frame indicates producer name, model, own weight, max. weight, max. pressure of the hydraulic system, and max. pressure of the spray liquid system. Frame, boom centre frame, and inner/outer sections also have identification plates indicating boom type and part number of spare parts. If ordering spare parts, inform your dealer of these, so the right model and version are described.

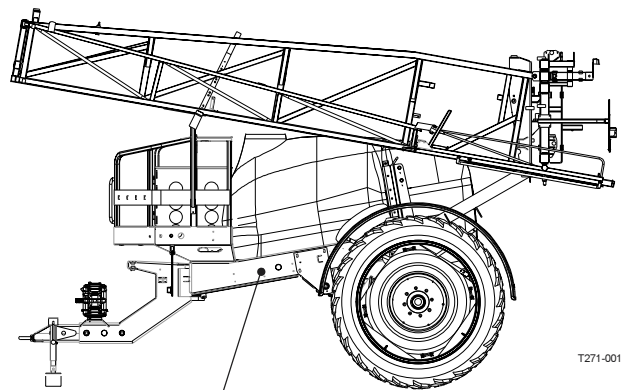

T271-0010x

HARDI INTERNATIONAL A/S			
HEJESHOJ ALLE 38, DK-2630 TASTRUP, DENMARK			
Fabr.-nat., Make, Marque, Marca: HARDI			
Type, Typ, Tipo: CH 2			
Serie nr., Serial No., Pz-identif.-No., Serien. Num., Serie:			
Fabr.-inst.-aar, Production Year, Baujahr, An. Fabricacion, Ano Fabr.-instacion:			
Kapacitet, Capacity, Kapacitet, Capacidad: L			
Imetriklouation:			
Statistisk. Orator, Local, Statist. Orator, Filiale, Pansion del Timor: ...ML ...			
Egenvekt, Unladen weight, Laegselvkt, P.V., Peso Propio: ...ML ...			
Spær-, type	Leet, meter	Max. dræbt., max. belt size	Max. dræbt., max. belt size
Dimension	Dræbt. No.	Dræbt. No.	Dræbt. No.
230/95 R48	134 AB	6500 kg	6070 kg
230/95 R48	135 AB	6700 kg	6140 kg
230/95 R48	140 AB	6900 kg	6500 kg
230/95 R48	142 AB	6950 kg	6550 kg
21,4816	145 AB	6980 kg	6500 kg

HARDI INTERNATIONAL A/S	
HEJESHOJ ALLE 38, DK-2630, DENMARK	
Model:	
Serial no.:	
Technical specifications: see the Users Instruction Manual I	

HARDI INTERNATIONAL A/S	
HEJESHOJ ALLE 38, 2630 TASTRUP, DENMARK	
Type:	637671
Zul. Gesamtgewicht:	6500 kg
Zul. Stützlast:	1350 kg
D-Wert: 24,9 kN	Max. Geschwindigkeit: 25 km/h

T279-0005  
T279-0002  
T279-0006

(Certain countries only)

# Description

## Sprayer use

The HARDI COMMANDER sprayer is for the application of crop protection chemicals and liquid fertilisers.

The equipment must only be used for this purpose. It is not allowable to use the sprayer for other purposes.

If no local law demands that the operator must be certified to use the spray equipment, it is strongly recommended to be trained in correct plant protection and in safe handling of plant protection chemicals to avoid unnecessary risk for persons and the environment when doing the spray job.

## Unloading the sprayer from the truck

For the unloading of the sprayer a crane or a fork lift is needed. When loading with a crane please observe the lifting points as shown on the illustration, and make sure that the straps or belts used for lifting are strong enough.

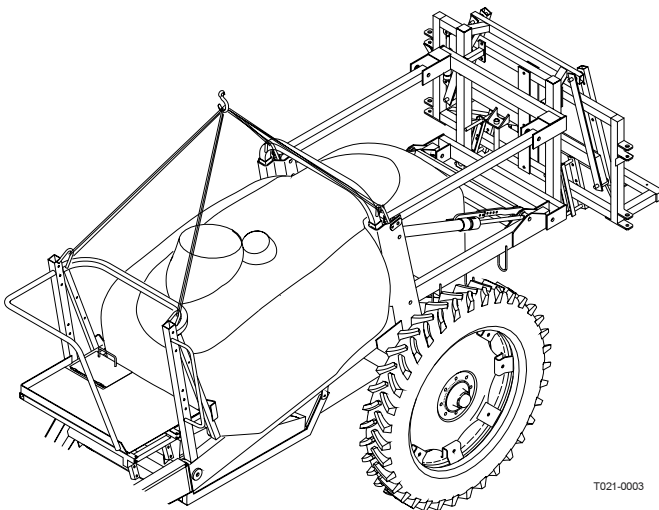

## Before putting the sprayer into operation

Although the sprayer has been applied with a strong and protective surface treatment on steel parts, bolts etc. in the factories, it is recommended to apply a film of anticorrosion oil (e.g. CASTROL RUSTILLO or SHELL ENSIS FLUID) on all metal parts in order to avoid chemicals and fertilisers discolouring the enamel.

If this is done before the sprayer is put into operation for the first time, it will always be easy to clean the sprayer and keep the enamel shiny for many years.

This treatment should be carried out every time the protection film is washed off.



# Sprayer setup

## Connecting the sprayer

### Drawbars

Mounted on the chassis in a centre pivot, the drawbar can be either standard fixed or optionally steered. Steering can be hydraulically operated or it can be automatically controlled (TRAIL CONTROL).

### Overview - Drawbar systems

COMMANDER LPY/LPZ	FIXED DRAWBAR	STEERING DRAWBAR	TRAIL CONTROL	SELF TRACK
2200/2800	Yes	Yes	Yes	Yes
3200/4200	Yes	Yes	Yes	No

035

Following drawbar extensions are available. The drawbar extensions are available - steering or fixed - for both high and low tractor hitch points. Each drawbar is available in a long or a short version.

### Overview - Drawbar extensions

Drawbar extensions	COMMANDER 2200/2800	COMMANDER 3200/4200
	HIGH and LOW hitch	HIGH and LOW hitch
Swivel type Ø33	No	Yes
Swivel type Ø36	Yes	No
Zugmaul Ø40	Yes	Yes
Hitch Ø50 (ISO 5692)	Yes	Yes

All drawbars are available in a long and a short version

034

Swivel type

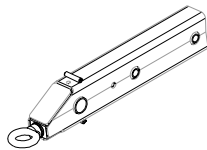

Zugmaul

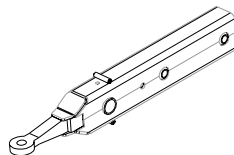

Hitch (ISO 5692)

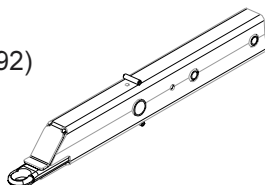

T251-0014x

### Mounting the drawbar extension

The extension piece is inserted into the opening of the drawbar, fastened by two main bolts through the two holes A and secured by two linch pins.

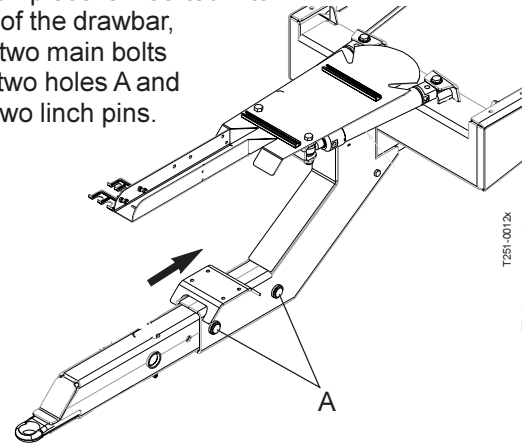

T251-0012x

### Support leg

The support leg is stored in the bracket on the sprayer's right side when the sprayer is attached to the tractor.

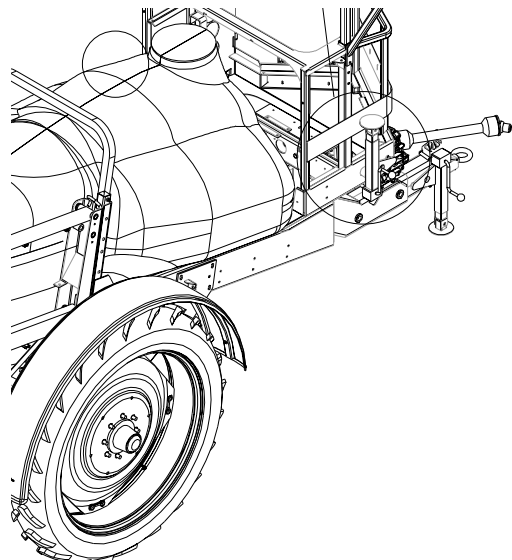

T142-0028x

To remove the support leg: Lift the leg, remove the linch pin and pull out the support leg.

The support leg can then be mounted to the drawbar extension and secured by linch pin.

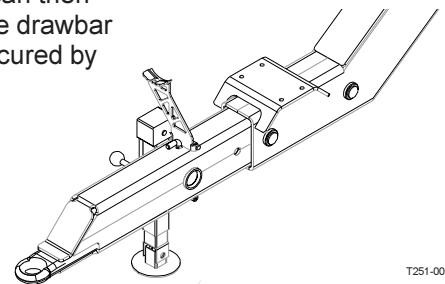

T251-0012x

# Sprayer setup

## Fixed drawbar

Make sure the drawbar points straight ahead from its position on the trailer. If not, the two turn buckles **A** can be adjusted till the drawbar is centred.

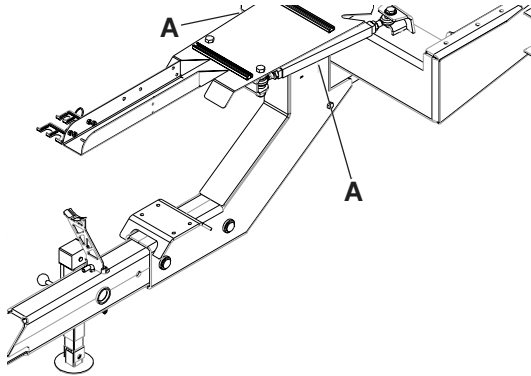

T251-0012x

## STEERING drawbar

### Transport lock (if fitted)

The transport lock is a safeguard that will keep the drawbar in a centred position in case of hydraulic leakage during transport on public roads.

The transport lock is fixed by linch pins.

If necessary, the transport lock can be adjusted by turning the turnbuckle.

## SELF TRACK for COMMANDER 2200/2800

SELF TRACK is connected as follows:

1. Attach the tractor lower links in the two mountings of the SELF TRACK. Adjust the length of the drawbar if necessary - to obtain the best tracking, choose the setting where the distance  $X$  is equal to distance  $Y$ . Secure with linch pins.

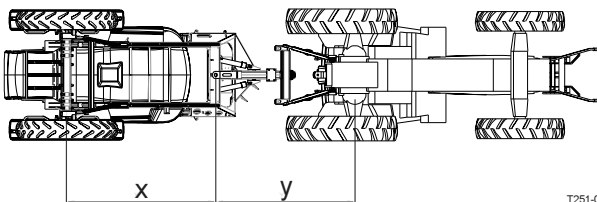

T251-0015x

2. Attach safety chains to top link clevis. The chain will prevent the transmission shaft from being damaged if the lift arms are lowered too far. Adjust the chain length so the chains are tight when the tractor P.T.O. and pump shaft are in a horizontal line.

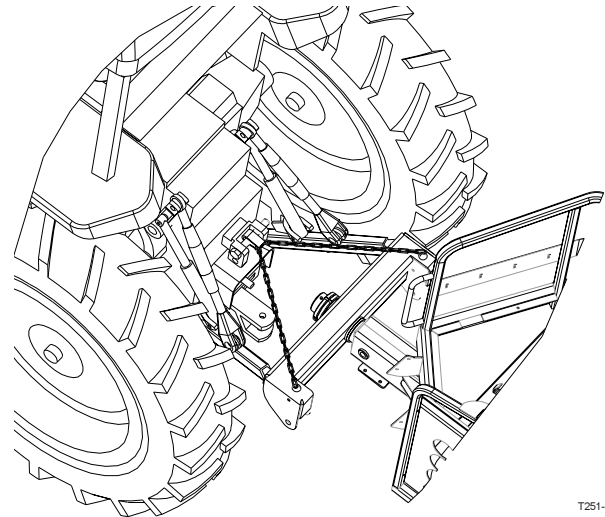

T251-0016x

**NOTE!** If possible, lock the tractor hydraulic lever when the lift arms are in the correct position to avoid the sprayer weight resting on the stabiliser chains.

3. Tighten the lift arm stabiliser chains.



**WARNING!** Do not stand in the area around the drawbar during manoeuvring.

## TRAIL CONTROL

Please refer to separate instruction book.

## Hose package support

To prevent hoses and wiring from being damaged by the tractor wheels, all hoses, cables and wires are held by the hose bracket **A** fitted to the drawbar.

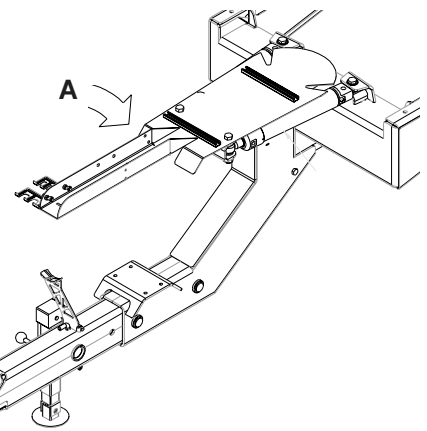

T251-0012x

Check that the length of the hoses and cables are sufficient by tight turns.

# Sprayer setup

## Transmission shaft

### Operator safety

To avoid accidents and personal injuries, note the following recommended precautions and safe operation practices.

1. Always STOP ENGINE before attaching the transmission shaft to tractor P.T.O. - most tractor P.T.O. shafts can be rotated by hand to facilitate spline alignment, when engine is stopped.
2. When attaching the shaft, make sure that the snap lock is FULLY ENGAGED - push and pull shaft until it locks.



**WARNING!** ROTATING TRANSMISSION SHAFTS WITHOUT PROTECTION GUARDS ARE FATAL.

3. Always keep protection guards and chains intact and make sure that it covers all rotating parts, including CV-joints at each end of the shaft. Do not use without protection guard.
4. Do not touch or stand on the transmission shaft when it is rotating - safety distance: 1.5 meter.
5. Prevent protection guards from rotating by attaching the chains allowing sufficient slack for turns.
6. Make sure that protection guards around tractor P.T.O. and implement shaft are intact.
7. Always STOP ENGINE and remove the ignition key before carrying out maintenance or repairs to the transmission shaft or implement.

### Installation of transmission shaft

First installation of the transmission shaft is done in the following way:

1. Attach sprayer to tractor and set sprayer height in the position with shortest distance between the tractor and sprayer pump P.T.O. shafts.
2. Stop engine and remove ignition key.
3. If transmission shaft must be shortened, the shaft is pulled apart.

Fit the two shaft parts at tractor and sprayer pump and measure how much it is necessary to shorten the shaft.

Mark the protection guards.

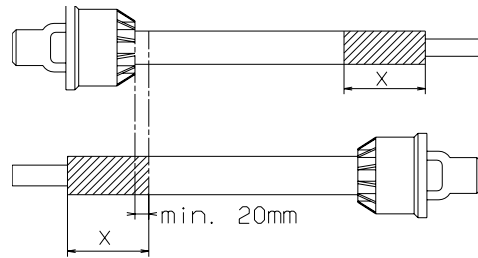

T259-0004

**NOTE!** The shaft must always have a minimum overlap. The size of this overlap depends on the pump model:

#### Pump with 6 splines/540 r.p.m.

The shaft must always have an overlap of minimum  $\frac{1}{3}$  of the length.

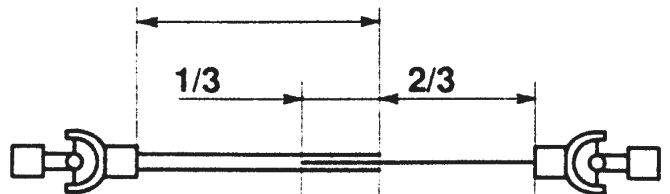

T259-0011

#### Pump with 21 splines/1000 r.p.m.

The shaft must always have an overlap of minimum  $\frac{2}{3}$  of the length.

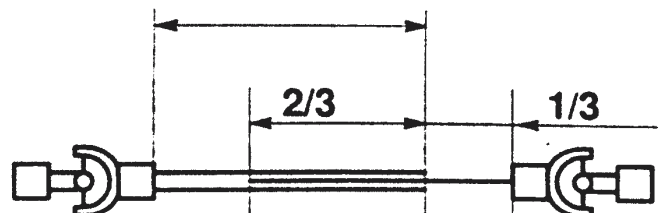

T259-0011

4. The two parts are shortened equally. Use a saw, and file the profiles afterwards to remove burrs.

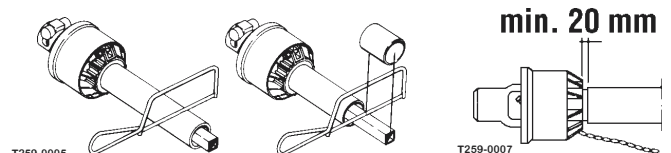

T259-0005

T259-0007

5. Grease the tractor P.T.O. and pump shafts.
6. Fit the shaft to tractor P.T.O. and sprayer pump shaft.

**NOTE:** Female part marked with a tractor towards tractor!

# Sprayer setup

- Twist the collar and slide the yoke onto the P.T.O. shaft.

Make sure that the lock engages by pushing and pulling the shaft forwards and backwards.

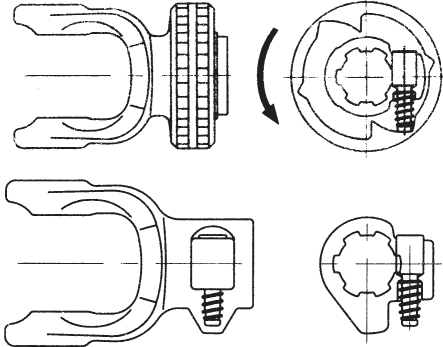

- Fit the chains to prevent the protection guards from rotating with the shaft.

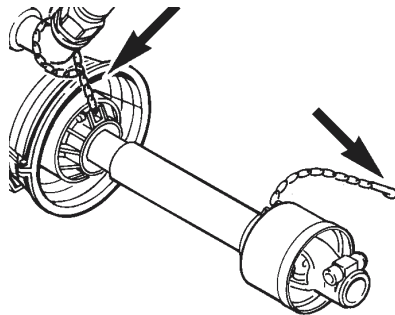

**NOTE!** To ensure long life of the transmission shaft try to avoid working- angles greater than  $35^\circ$ . The wide angle shaft with Constant Velocity Joint works in angles up to  $70^\circ - 80^\circ$  for short periods (during turning etc.).

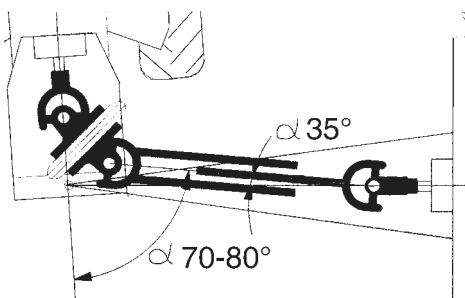

# Sprayer setup

## Track gauge

### Altering the track gauge

The track gauge of the COMMANDER can be altered stepless as follows,

1. Measure the current track gauge (centre RH tyre to centre LH tyre). Each side must be extended or retracted half the desired alteration.
2. Attach the sprayer to tractor and engage tractor parking brake.

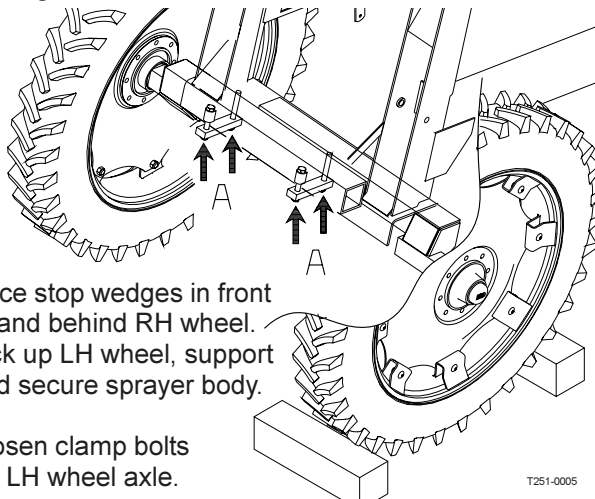

3. Place stop wedges in front of and behind RH wheel. Jack up LH wheel, support and secure sprayer body.
4. Loosen clamp bolts for LH wheel axle.
5. Loosen the nut **B** on the brake operating arm. Extend/retract this arm according to the adjustment of the axle.

COMMANDER  
without suspension

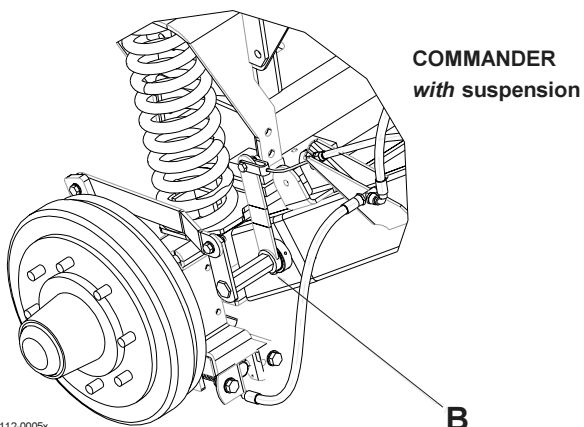
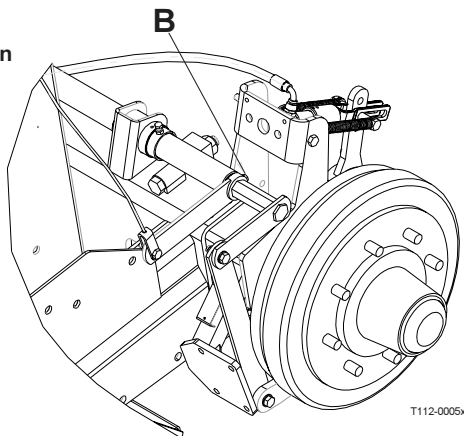

T112-0005x

6. Extend or retract the axle. A sack barrow and a rod will facilitate the operation.

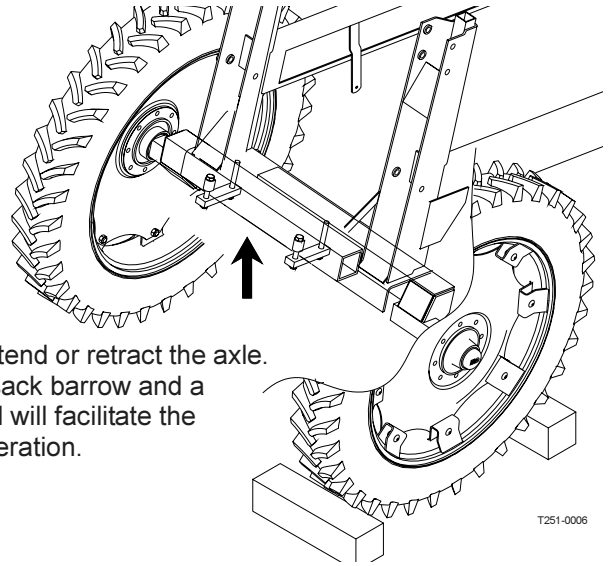

T251-0006

7. If the rim position must be changed, do this first and fine adjust by extending or retracting the axles. Remember to tighten the wheel nuts to the specified torque:

Rim plate to rim:	280 + 30 Nm (207 + 22 lbf)
Rim plate to hub:	490 Nm (288 lbf)

8. Tighten the clamp bolts to a torque of:

280 Nm (207 lb.ft)	for 2200/2800
390 Nm (289 lbf)	for 3200/4200.

9. Tighten nut **B** again.

**IMPORTANT!** Place the jack under the axle and lift the wheel to remove load from the clamps before tightening the clamp bolts to the specified torque.

10. Repeat the procedure on RH wheel.
11. Check the distance from centre tyre to centre of tank frame is equal at RH and LH.
12. Retighten clamp bolts and wheel bolts to specified torque after 8 hours of work.

# Sprayer setup

## Adjustment ranges - track width

The maximum track width for all models is **2250 mm**.

The minimum track width depends on the parameters in the charts beneath and whether the sprayer is equipped with suspended axle or not. Please refer to the following charts (all figures are in mm).

### Min. track width - Sprayers without suspension

<b>CM plus 2200</b>	<b>Tyre size</b>						
Sprayer with:	9.5 x 44"	9.5 x 48"	11.2 x 44"	11.2 x 48"	12.4 x 46"	18.4 x 38"	20.8 x 38"
Flange hub							
Brake hub							
Mudguards							

<b>CM plus 2800</b>	<b>Tyre size</b>						
Sprayer with:	9.5 x 44"	9.5 x 48"	11.2 x 44"	11.2 x 48"	12.4 x 46"	18.4 x 38"	20.8 x 38"
Flange hub							
Brake hub							
Mudguards							

<b>CM plus 3200</b>	<b>Tyre size</b>						
Sprayer with:	9.5 x 44"	9.5 x 48"	11.2 x 44"	11.2 x 48"	12.4 x 46"	18.4 x 38"	20.8 x 38"
Flange hub							
Brake hub							
Mudguards							

<b>CM plus 4200</b>	<b>Tyre size</b>						
Sprayer with:	9.5 x 44"	9.5 x 48"	11.2 x 44"	11.2 x 48"	12.4 x 46"	18.4 x 38"	20.8 x 38"
Flange hub							
Brake hub							
Mudguards							

### Min. track width - Sprayers with suspension

<b>CM plus 2200</b>	<b>Tyre size</b>						
Sprayer with:	9.5 x 44"	9.5 x 48"	11.2 x 44"	11.2 x 48"	12.4 x 46"	18.4 x 38"	20.8 x 38"
Flange hub							
Brake hub							
Mudguards							

# Sprayer setup

CM plus 2800	Tyre size						
Sprayer with:	9.5 x 44"	9.5 x 48"	11.2 x 44"	11.2 x 48"	12.4 x 46"	18.4 x 38"	20.8 x 38"
Flange hub							
Brake hub							
Mudguards							

CM plus 3200	Tyre size						
Sprayer with:	9.5 x 44"	9.5 x 48"	11.2 x 44"	11.2 x 48"	12.4 x 46"	18.4 x 38"	20.8 x 38"
Flange hub							
Brake hub							
Mudguards							

CM plus 4200	Tyre size						
Sprayer with:	9.5 x 44"	9.5 x 48"	11.2 x 44"	11.2 x 48"	12.4 x 46"	18.4 x 38"	20.8 x 38"
Flange hub							
Brake hub							
Mudguards							

It is not permitted to fit dual wheels!

**IMPORTANT!** On TRACKER models a minimum track gauge of 1800 mm is strongly recommended to ensure stability and to avoid the sprayer tipping over.

**NOTE!** The wider the track gauge, the better the stability of the sprayer and boom.

## Permitted rim positions

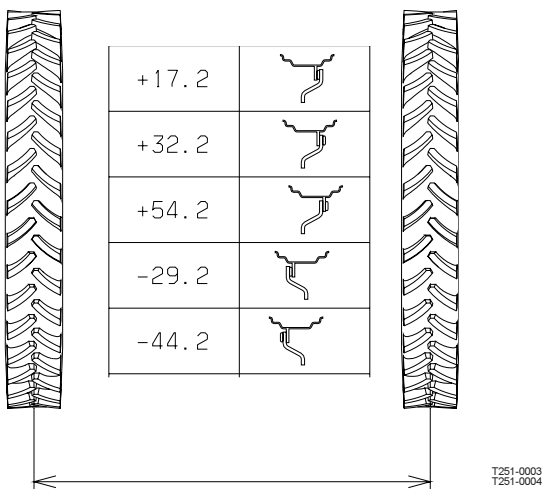

**WARNING!** When altering track gauge by turning rims and rim plates the maximum permitted offset between centre wheel and hub flange must be observed:

Max offset, hub flange and centre rim:

CM	Min. rim offset	Max. rim offset
2200/2800	-45	+55
3200/4200	-33	+33

**IMPORTANT!** Tyre sizes **18.4 x 38"** and **20.8 x 38"** are not permitted in any "+ position", only use the "- positions".



# Sprayer setup

## Hydraulic systems

### Hydraulics COMMANDER-HAY

#### Tractor Operated Hydraulics

Connection requirements for COMMANDER-HAY are one double acting and one single acting spool valve.

*Single acting valve:* Boom lift, up/down

*Double acting valve:* Boom folding and unfolding

Ensure the snap couplers are clean before connection!

If hydraulic slanting control is fitted another double acting spool valve on the tractor is required.

**NOTE!** The hydraulic system requires a minimum oil pressure of 130 bar, max. oil pressure of 210 bar and an oil capacity of approx. 5 litres. After having operated the boom and the system has been filled with oil, check tractor's hydraulic oil level and top up if necessary.

### Hydraulics COMMANDER-HAZ

#### Direct Acting Hydraulic system

The D.A.H. system requires a double acting hydraulic outlet. The hydraulic hoses are marked with arrows to indicate direction of oil flow.

The D.A.H. system requires an oil flow between 10 and 90 l/min (19.8 Imp. gal/min.) and a min. pressure of 130 bar (1886 p.s.i.) The system has a built-in flow regulator that maintains constant speed on hydraulic movements.

The hydraulic distribution block is situated underneath the platform floor.

The valves on the block are operated by means of manual override and each valve can be regulated to be open or closed.

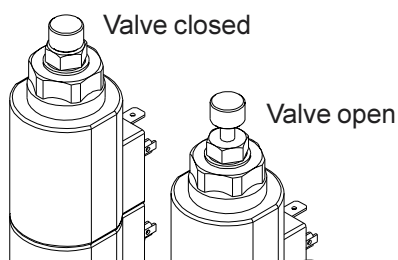

Before operating the hydraulics, the valves on the sprayer's hydraulic distribution block should be adjusted according to the specific tractor model (please refer to scheme later in this part).

If you have doubt about which type of hydraulic system your tractor is equipped with, please ask your tractor dealer.

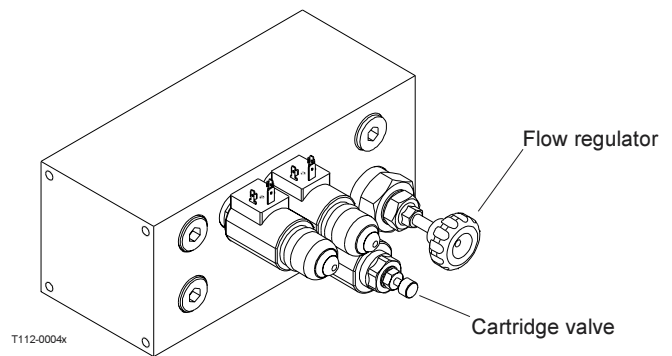

Tractor/hydraulic system	Cartridge valve	Flow regulator
<b>Standard</b> (constant flow tractor)	<b>Open</b>	<b>Open</b>
<b>Closed centre</b> (certain JD tractors)	<b>Closed</b>	<b>Closed</b>
<b>Load sensing</b> 1. <i>Without</i> external sensing line	<b>Open</b>	<b>Open</b>
<b>Load sensing</b> 2. <i>With</i> external sensing line	<b>Closed</b>	<b>Open</b>

029

### Load Sensing

Please consult your tractor dealer for correct setup and correct connection.

Certain tractor models are able to use Load Sensing *without* connecting an external sensing line (setting 1 in scheme). But if optimal sensing control pressure *cannot* be obtained, an external sensing line needs to be mounted (setting 2 in scheme).

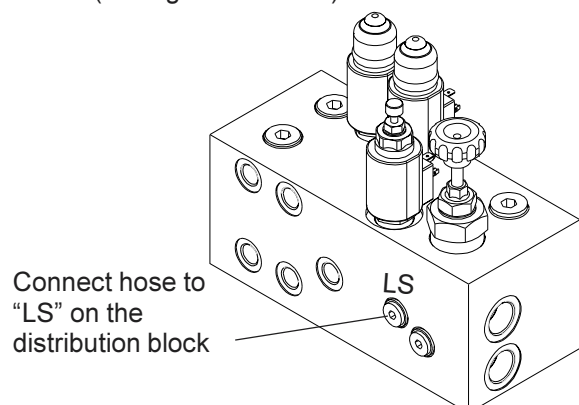

### Requirements - Load Sensing hose:

1/4" Standard hose

Max. rated working pressure = 200 bar.

**IMPORTANT!** It is of essential importance that connectors on sensing line are kept totally clean. Failure to do so will cause impurities entering the pump and thereby cause damages to vital pump parts.



# Sprayer setup

## Control boxes and power supply

Power requirement is 12V DC.

Note Polarity!

For EVC: Brown pos. (+), Blue neg. (-).

For D.A.H.: White pos. (+), Black neg. (-).

The control boxes for EVC-operating unit and D.A.H. are fitted in the tractor cabin at a convenient place. Tapping screws can be used for mounting.

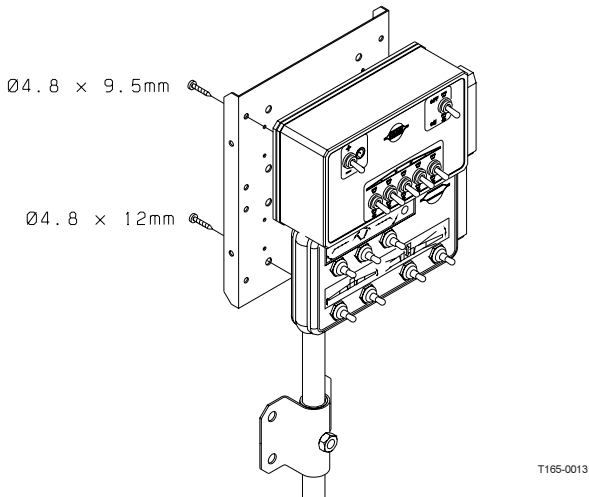

The wires must have a cross sectional area of at least 4.0 mm to ensure sufficient power supply. For the EVC-operating unit the tractor circuit should have an 8 Amp fuse and for the D.A.H. an 16 Amp fuse.

Control box for	Polarity (wire colour)		Required Fuse, Amp
	Positive +	Negative -	
EVC operating unit	Brown	Blue	8
D.A.H. Hydraulic	White	Black	16
MANIFOLD valve	Brown	Blue	8

Use the HARDI Electric distribution box (No. 817925) if the tractor has a doubtful power supply.

# Sprayer setup

## Brakes

### Emergency and parking brake (if fitted)

The parking brake lever has two function modes, which are determined by the small pawl control clip (A).

To change between the two modes, turn the clip.

Pos. 1: The pawl control clip must point away from the pawl.

Pos. 2: The pawl control clip must rest against the pawl.

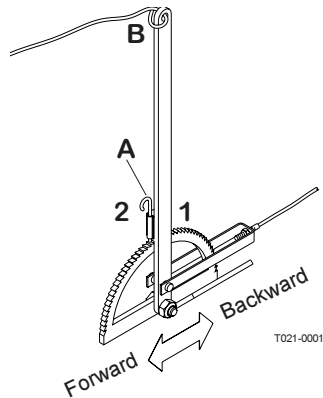

### To disengage the parking brake:

1. Set pawl control clip in pos. 1.
2. Pull the lever a little forward to release the pawl from the ratchet and then push the lever fully backwards.

### To engage the parking brake:

1. Set pawl control clip in pos. 2.
2. Pull the lever firmly forwards until parking brake is fully engaged.

### Emergency brake

1. Set pawl clip in pos. 2.
2. Attach the rope from the hole in top of the handbrake lever (B) to e.g. the tractor top link attaching point. If the sprayer is accidentally unhooked during transport the rope will apply the parking brake before the rope breaks.

**IMPORTANT!** To ensure safe engagement and to avoid damages to the parking brake use rope with an ultimate stress between 690 N (155 lb.) and 785 N (176 lb.).

### Hydraulic activated brakes (if fitted)

This requires a special trailer brake valve attached to the tractor hydraulic and brake system. Connect the snap coupler to the tractor brake outlet. When the tractor brakes are applied, the trailer brakes will work proportionally to the tractor brakes, and ensure safe and effective braking.

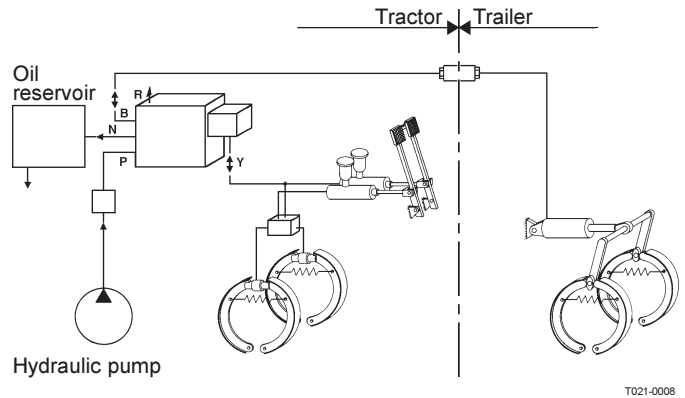

**WARNING!** Do not connect the brakes directly to the tractor hydraulics without the brake valve. The trailer brake power cannot be controlled, and braking will therefore be hazardous.

**IMPORTANT!** Max. oil pressure is 150 bar (2175 p.s.i.) in the brake line.

Relieve parking brake before driving.

### Air activated brakes (if fitted)

This system requires a tractor with compressor and air brake system with out-let(s) for trailer brakes.

**IMPORTANT!** The load apportioning valve must be set at the position corresponding to the load on the trailer, for obtaining optimal air pressure to the trailer brakes.

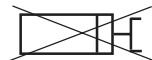
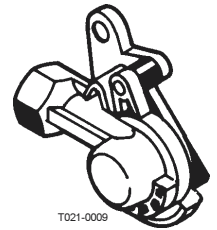

= Relieved



= Half full tank



= Empty tank



= Full tank



**WARNING!** Driving with wrong load apportioning valve setting, will make the brakes under- or over-apply, which can cause hazardous situations.

**NOTE!** If the air hose(s) are disconnected with air in the brake air tank, control pressure will be dumped and the brakes will engage fully. If the sprayer must be moved with air in the tank and without the air hose(s) connected to the tractor, the load apportioning valve must be set at "relieved" to disengage the brakes. Remember to reset the handle to brake position again afterwards. When parking the sprayer, always engage the parking brake, as the air brakes will only be engaged as long as there is air in the tank! Cover the couplings with the dust flaps when hoses are disconnected.

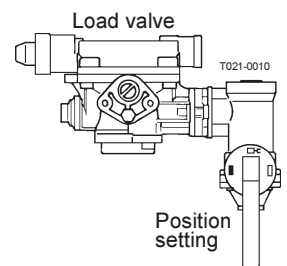

# Sprayer setup

---

## **Single-line brakes (if fitted)**

Flip the snap coupler protection flap away and connect the brake system snap coupler to the tractor outlet (black) and let the compressor fill the sprayer's air reservoir.

Check brake circuit for leaks.

## **Dual-line brakes (if fitted)**

Flip the snap coupler protection flaps away and connect the two snap couplers for supply and control to the tractor outlets, and check brake circuits for leaks.

The couplers are colour coded and secured against incorrect attachment:

Red = Supply line (RH)

Yellow= Control line (LH)

Relieve parking brake before driving

# Sprayer setup

## Counter weight (TRACKER models only)

To improve stability on TRACKER models, extra weight can be added by means of liquid-filled tyres.

The standard tyre valve is an universal air-water valve.

The tyres can be filled with liquid to max. 75% of their total volume. The table below indicates the 75% volume.

Tyre size	Max. litres of liquid per tyre
9.5 x 44"	101
9.5 x 48"	108
11.2 x 44"	133
11.2 x 48"	144
12.4 x 46"	178
16.9 x 38"	285
18.4 x 38"	390
20.8 x 38"	466

1 litre = 0.264 US Gal. 1 litre = 0.22 Imp. Gal.

001

Use a mixture of water and  $\text{CaCl}_2$  to avoid frost damage as described in table below:

$\text{CaCl}_2$ per litre water	Protection to
200 g (7.1 oz)	-15°C (30.6°F)
300 g (10.6 oz)	-25°C (12.6°F)
435 g (15.4 oz)	-35°C (-5.4°F)



**WARNING!** It is very important that the  $\text{CaCl}_2$  is added to the water and agitated until it is fully dissolved. Never pour water on to  $\text{CaCl}_2$ ! If you get  $\text{CaCl}_2$  in the eyes, flush instantly with cold water for at least 5 minutes and seek medical advice afterwards.

**IMPORTANT!** The tyres must be liquid filled to max. 75% of total tyre volume. Fill only the qty. of liquid necessary to obtain sufficient stability of the sprayer. Do not fill liquid and  $\text{CaCl}_2$  mixture in tyres without tubes!

To fill the tyres:

- Jack up the wheel and rotate wheel till the valve is positioned at "12 o'clock".
- Remove the valve body and fill liquid until it reaches the valve.
- When surplus liquid is drained through the valve stem fit the valve body again.
- Adjust tyre pressure and lower the wheel. (Please refer to table for correct tyre pressure).

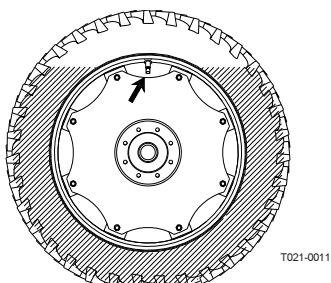

T021-0011

Recommended tyre pressure:

Tyre size RC 95	Recommended inflation pressure in bar (p.s.i.)	Minimum Load Index A8/A2
230/95 R44 (9.5 x 44)	3.6 (52)	134/145
230/95 R48 (9.5 x 48)	3.6 (52)	136/147
270/95 R44 (11.2 x 44)	3.6 (52)	140/151
270/95 R48 (11.2 x 48)	3.6 (52)	142/153
12.4 x 46	3.6 (52)	147/158
16.9 x 38	1.6 (23)	141/152
18.4 x 38	1.6 (23)	147/144
20.8 x 38	1.2 (18)	154/151

002

**NOTE!** When filling the tyres the valve should be positioned at 12 o'clock and when adjusting the tyre pressure, the valve should be positioned at 6 o'clock.

To empty the tyres:

- Rotate wheel till the valve is positioned at "6 o'clock."
- Remove the valve body and let out the liquid. Retain liquid in an appropriate container.
- To empty the tyre completely the tyre is inflated and a thin drain tube is lead to the bottom of the tyre. The air pressure will now empty the remaining liquid.
- Remove the drain tube, fit the valve and inflate the tyre to specified pressure. See the table "Tyre pressure".

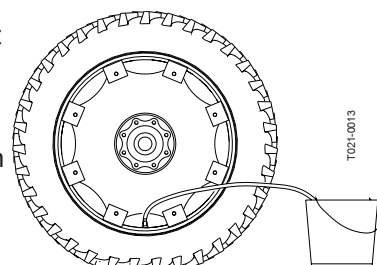

T021-0013

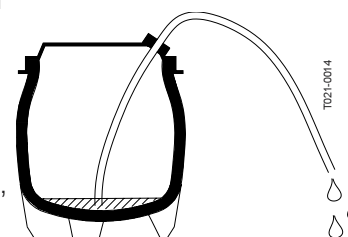

T021-0014

**NOTE!** Disposal of  $\text{CaCl}_2$  has to take place according to local legislation.

# Sprayer setup

## Transport

### Roadworthiness

When driving on public roads and other areas where the highway code applies, or areas where there are special rules and regulations for marking and lights on implements, observe these and equip implements accordingly.

**NOTE!** Max. driving speed is 25 km/h for models *without* brakes and 40 km/h for models equipped *with* brakes.

### Rear lights (if fitted)

Connect plug for rear lights to the tractor's 7-pin socket, and check function of rear lights, stop lights and direction indicators on both sides before driving.

The wiring is in accordance with ISO 1724. See section on Technical specifications.

Before transport on public roads the front warning boards with position lamps must be folded out (fitted in certain countries only).

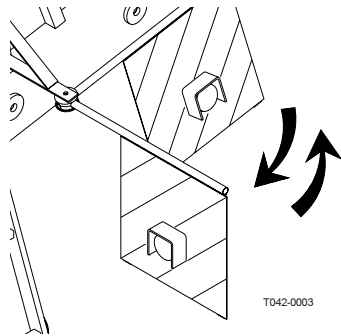

### Boom transport safety chain (if fitted)

Fit the safety chains as shown below before transport on public road.

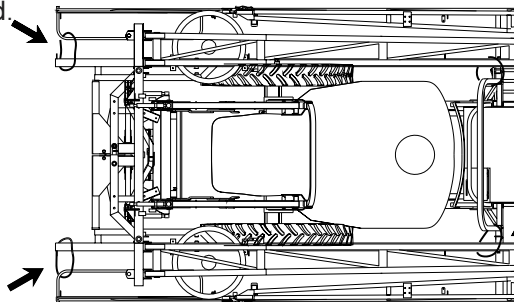

### Stop wedges (if fitted)

Before driving, remove the stop wedges and place them in the storage brackets.

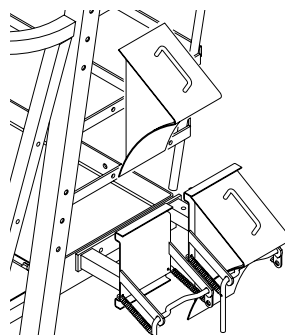

## Transport brackets, height setting

The transport brackets can be set in different positions. Thereby it is possible to obtain different transport heights and suitable clearance above various tractor cabins.

When changing the setting of the transport brackets it is done as a combination of adjusting the transport brackets themselves (1) and adjusting the transport locks (2). Always choose a transport height as low as possible.

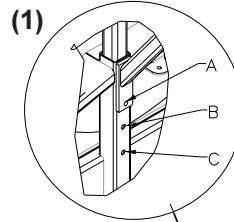

### 1. Transport brackets

The transport bracket can be set at three different positions A, B or C.

Loosen the bolt to change position and replace it according to new setting. The setting must be identical on both sides.

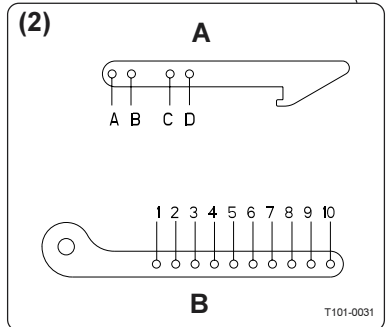
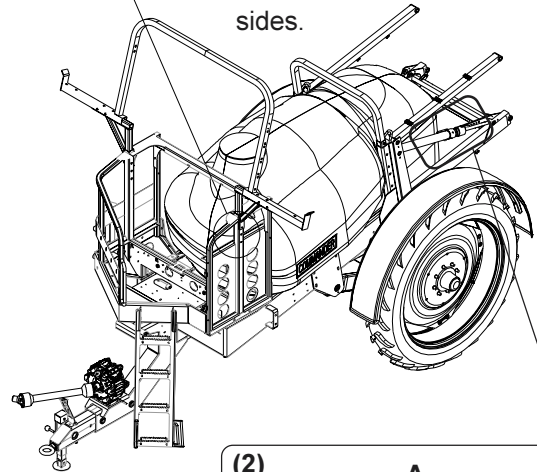

### 2. Transport lock

To change position:

1. Lift and unfold inner sections till lock is disengaged.
2. Loosen and remove the two bolts, which keep the parts **A** and **B** assembled.
3. Reassemble **A** and **B** according to desired hole combination.

**NOTE!** Always use both bolts to assemble the lock. The setting must be identical on both sides.

**NOTE!** The rear settings must correspond to the front settings so the boom is resting on the front as well as rear brackets.



**WARNING!** The max. transport height must never exceed 4.0 m (13.1 ft.). Always measure the actual total height and choose settings not exceeding 4.0 m.

# Sprayer setup

## Transport lock

When the boom is unfolded: Inspect the gap between the bolt A and the frame. Correct position = 1 mm gap.

If necessary, adjust the position of bolt A.

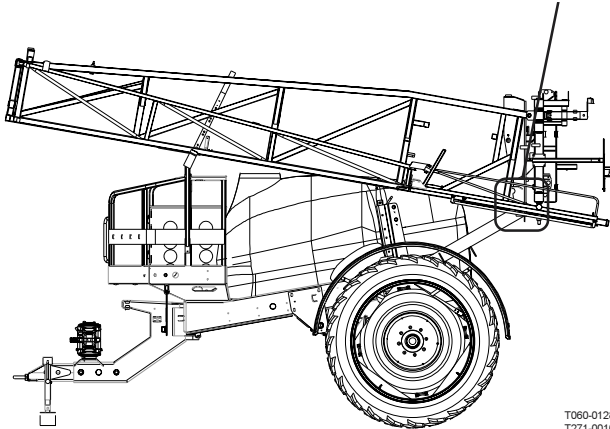
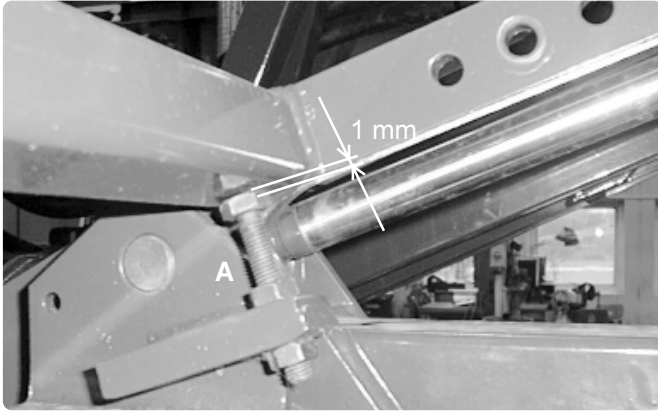

T060-0128  
T271-0010x

# Sprayer setup

## Driving Technique

### STEER TRACK and SELF TRACK

A trailer with articulating drawbar (TRACKER) behaves differently than a normal trailer.

In tracking position the vehicle centre of gravity is displaced further more compared to the vehicle centre line of a normal trailer.

Compared to a conventional trailer a TRACKER has decreased stability when turning, especially when turning on hillsides.

To avoid overbalancing, pay attention to these guidelines:

1. Avoid sudden, tight turns
2. Slow down before entering a curve or turning, and drive with a constant, low speed during the turn.
3. Never slow down too fast, never brake heavily and never stop suddenly in a curve, or when turning on a hillside, when the sprayer is articulated.
4. Be careful when turning on uneven ground
5. Set the track gauge as wide as possible
6. The proper function of the hydraulic damping is essential to obtain good stability
7. Keep stabiliser chains on the tractor's liftarms tight
8. For safety reasons, the following limitations are set for TRACKERS (with unfolded booms):

Speed by turning, max.	4 km/h (2.5 m.p.h.)
Ground inclination by turning, max.	8°
Track gauge, min.	Please see the part "Track gauge"

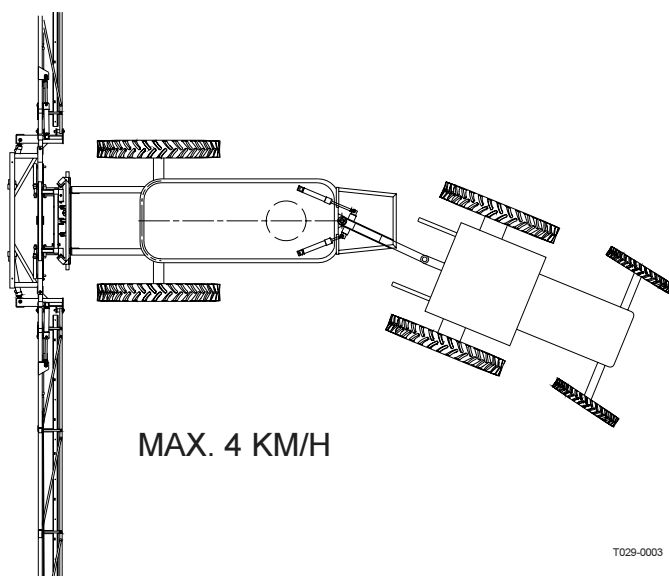

**NOTE!** HARDI cannot undertake any responsibility for any damages caused by the sprayer tipping over.

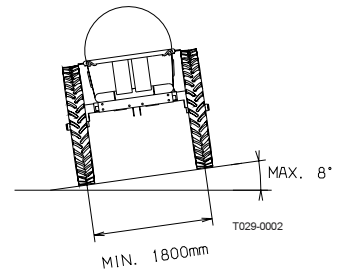

### STEER TRACK

(If the sprayer is equipped with HARDI NOVA, please see separate instruction book).

The articulating drawbar on STEER TRACK is to be operated manually via the D.A.H.

The switch on the D.A.H. control box is pushed side-wards to articulate the drawbar.

This is used when turning or as track correction when driving on slopes.

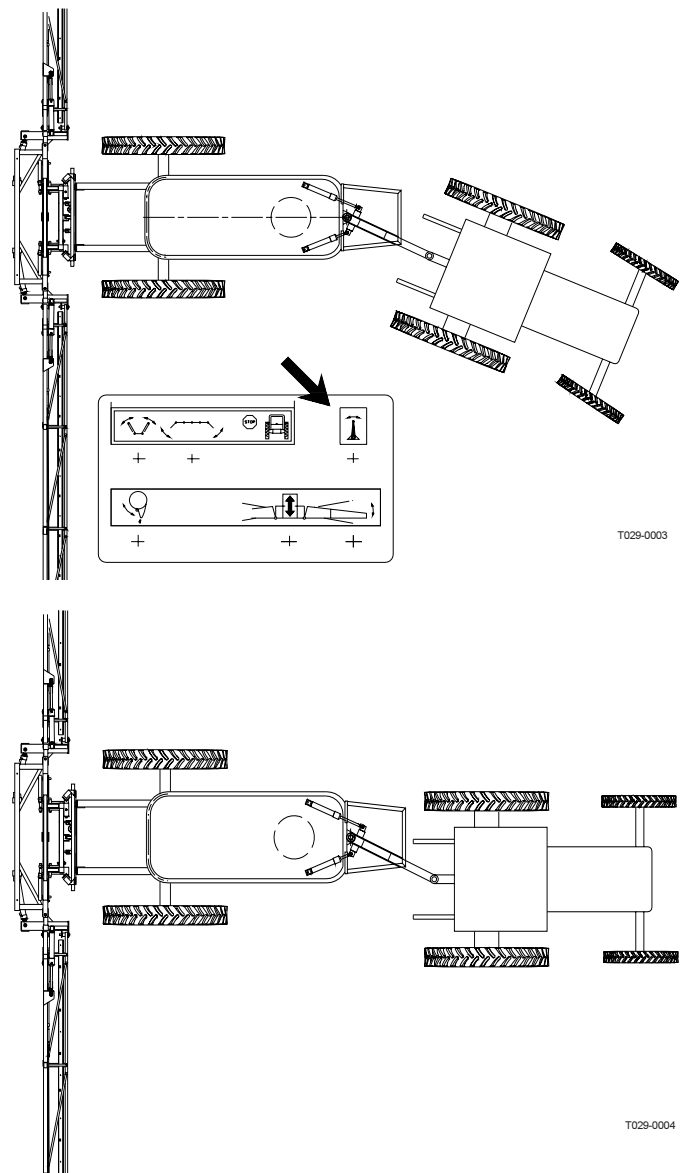



# Sprayer setup

---

## **SELF TRACK**

The SELF TRACK is always in tracking mode.

The SELF TRACK drawbar will always articulate when the tractor is turning and follow the tractor rear wheels.

The SELF TRACK drawbar is hydraulically damped to obtain stable trailing.



**WARNING!** Always drive the SELF TRACK very carefully on public roads, and be aware of the sprayer's behaviour. Slow down before turning, to avoid the vehicle from tipping over.

## **TRAIL CONTROL**

Please see separate instruction book.



# Sprayer setup

## Equipment - Standard and Additional Ladder

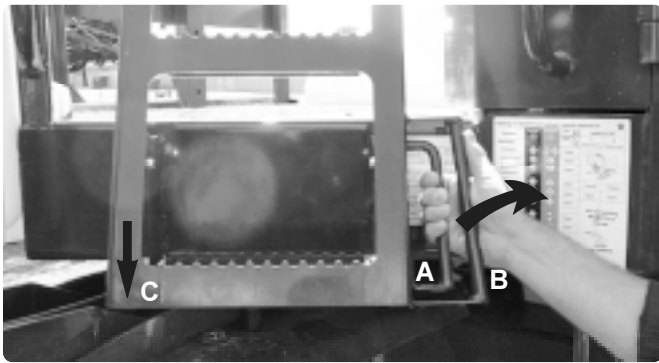

T060-0121

**Down:** Pull the handle **A** to disengage the locking device and drag down the ladder while supporting it by both handles (**B + C**)

**Up:** The ladder will lock automatically when it is fully retracted.

**NOTE!** Always retract the ladder before driving.

If necessary, grease the slide bars to make the ladder slide smoother.

## Platform

Access to the platform is possible via the ladder.

Hydraulic and electric components are situated underneath the platform floor. By lifting the platform floor, these components are accessible. Also the clean water tank is integrated in the platform.

The platform gives access to the clean water tank lid, the main tank lid, the top mounted suction filter and the self-cleaning filter, which is situated behind the wicket **A** on the backside of the MANIFOLD system.



T060-0114

## Tank level indicator

The actual tank level in the main tank can be observed on the tank level indicator **B**. The scale is displayed in litres or Imp. gal/US gal. (certain countries).

## Large storage Locker (if fitted)

The locker **A** can be mounted on the sprayer's right side acting as a storage for sealed pesticide containers. The locker is fitted to a mounting **B**, which is bolted to the frame of the trailer.

A drain in the bottom makes it possible to clean and drain the locker in case of leak by pesticide containers.

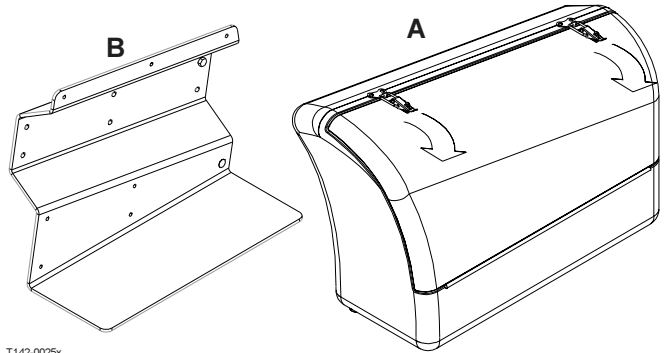

T142-0025x

## Small storage Locker (if fitted)

The locker **A** can be mounted next to the HARDI FILLER. It is for the purpose of storing pesticide containers in use, nozzles, calibration- and compound equipment. The locker is fitted to a mounting **B**, which is bolted to the frame of the trailer.

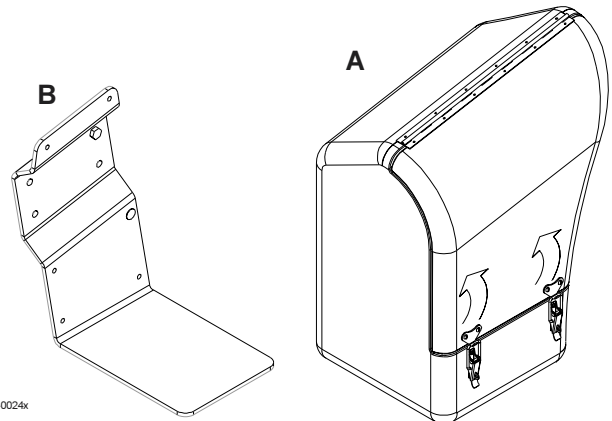

T142-0024x

A drain in the bottom makes it possible to clean and drain the locker in case of leak by pesticide containers.

## Front Locker (if fitted)

The locker is mounted to the front of the platform. It is for the purpose of storing non-contaminated protective gear, soap for hand washing etc.

The locker is split in two compartments for the separation of clean clothes from gloves with risk of contamination.

# Sprayer setup



T060-0110

A soap dispenser can be fitted in a device on the inside of the locker door.

**IMPORTANT!** Although this locker is situated in the non-contaminated zone of the sprayer and is meant for storing nontoxic items, it must **never** be used for storing food, beverage or other things meant for consumption.

## Boom and Work lights (if fitted)

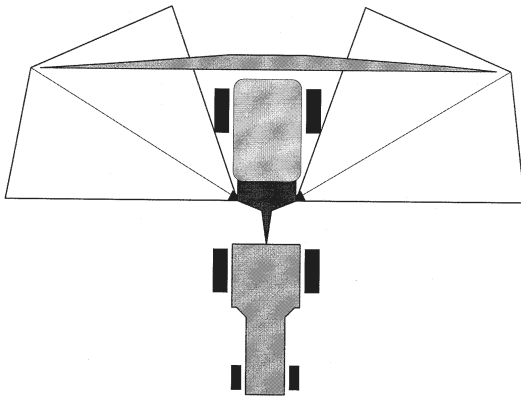

T271-0009

The 2 boom light lamps **A** are mounted to the railing of the platform (one at each side) and are positioned to lighten both boom wings.

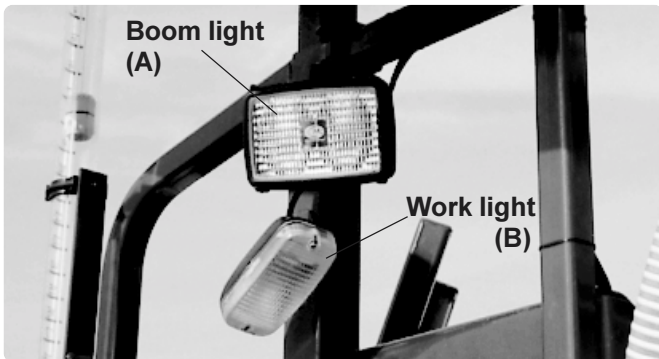

T060-0111

The work light lamp **B** is also mounted to the railing of the platform above the MANIFOLD valves. This lamp is positioned to lighten the HARDI FILLER + the MANIFOLD system.

It is recommended to switch of the rear lights of the tractor in order to save power consumption and to avoid reflection.

Power supply is via the 7-pin socket. Please see the *Installation Instruction* in the part *Technical specifications*.

## Selector switch

When mounting the selector switch **A** it is simply "clicked" into the cutout in the frame below the MANIFOLD valves and is thereby fastened to the frame.

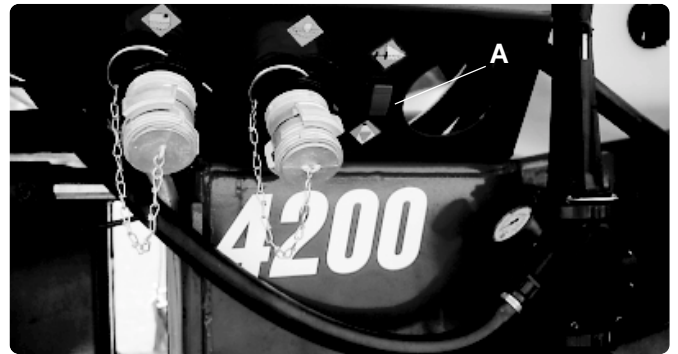

T060-0112

The switch has three positions:

1. Boom lights ON



2. Lights OFF (neutral)

3. Work light ON



T040-0000

T040-0001

## Connection box

The connection box is to be mounted underneath the platform floor.

1. Lift the platform floor
2. Open the connection box and mount the flat part of the box (**A**) by 4 screw to the 4 predrilled holes in the platform floor.

# Sprayer setup

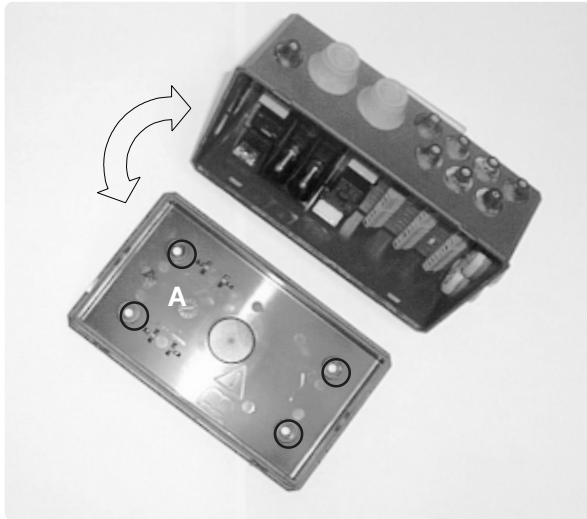

T060-0123

## Crop protection Kit (if fitted)

The kit consists of sheet, straw dividers and wheel brake covers.

### Sheet

The PVC sheet is fitted underneath the trailer and covers the undercarriage of the chassis



T060-0113

The sheet is lead through guiding rails fastened on both sides of the trailer.

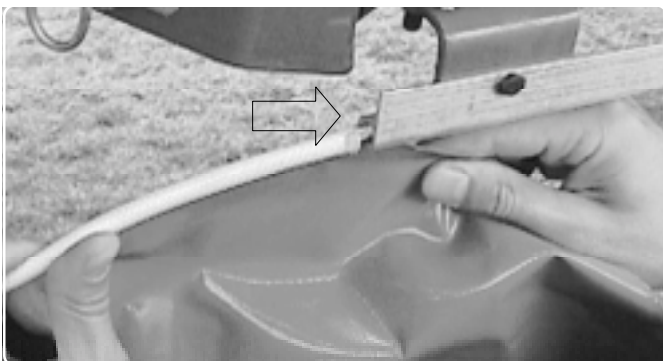

T066-0073

Each cutout in the shield is then fastened with a matching locking device, which are mounted along the lower part of the sprayer.



Drag the split, twist it 90° and drop the split again to lock it

T066-0074

### Strawdividers

A strawdivider can be fitted on each trailer wheel.

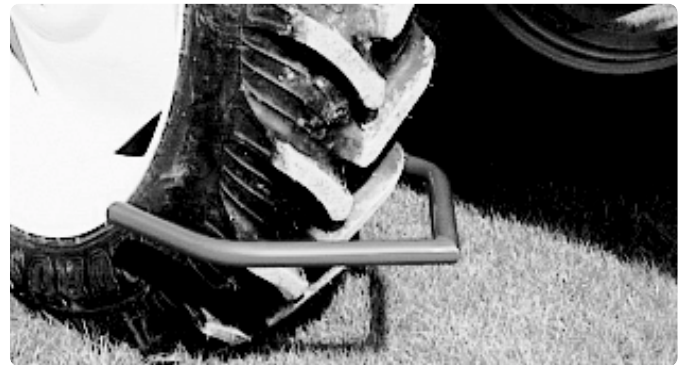

T060-0125

### Wheel brake covers

A wheel brake cover **A** can be mounted in order to cover the brake

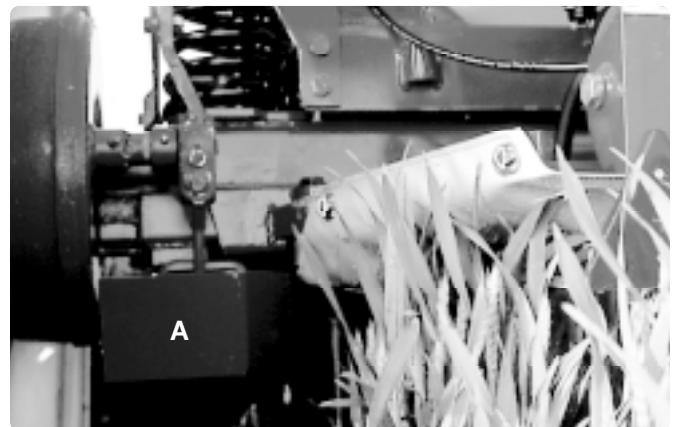

T060-0126

# Sprayer setup

## Mudguards (if fitted)



T060-0127

Mudguards can be fitted on the trailer wheels by means of a supporting frame which is bolted to a mounting on the wheel axle.

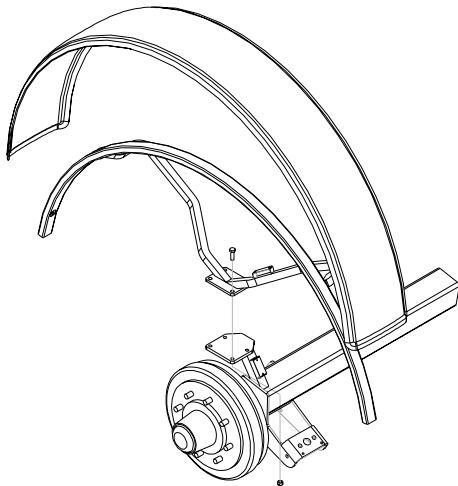

T162-0109x

Mudguards are available for all wheel configurations.



# Sprayer setup

## Disconnecting the sprayer

Always clean the sprayer - inside and outside - before disconnecting and parking it.

### Support leg

Before disconnecting from the tractor, make sure the support leg is properly fitted and secured by linch pin.

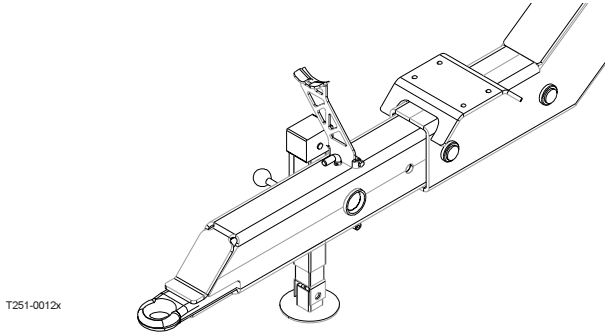

The support leg is stored in the bracket on the right side of the trailer when the sprayer is attached to the tractor. To remove the support leg: Lift the leg, remove the linch pin and pull out the support leg.



**WARNING!** To prevent the sprayer from tipping over, do not disconnect the sprayer from the tractor with the booms unfolded unless the boom is supported!

Always engage the parking brake (if fitted).

If no parking brake is fitted, or if local regulations requires so, place stop wedges in front of and behind the wheels.

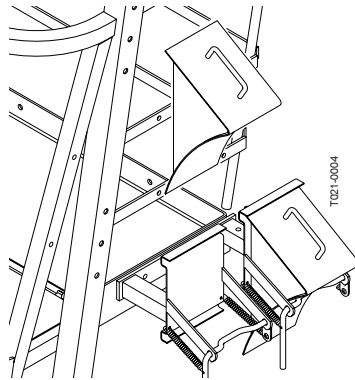

Remember to disconnect all hoses and cables from the tractor.



**WARNING!** If the sprayer is parked unattended avoid unauthorised persons, children and animals from having access to the sprayer.

## Transmission shaft support

The transmission shaft rests on the bracket **A** when not in use (Low hitch models).

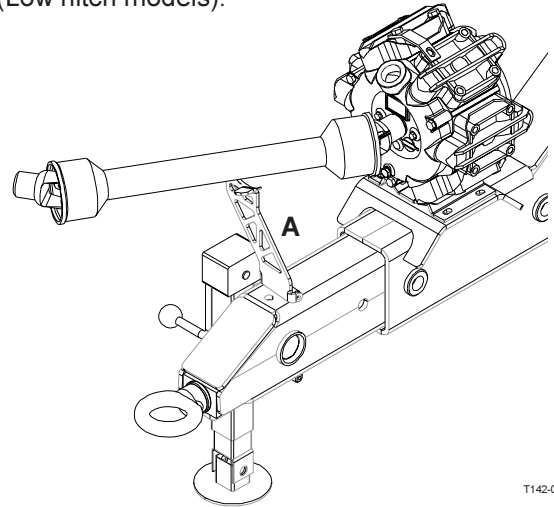

At High hitch models the transmission shaft is placed in the hook underneath the drawbar when not in use

# Operation

## Operating the boom



**WARNING:** Be cautious with initial use of the hydraulic system. If there is air in the system this may cause violent movements of the boom.

Therefore, take care that no persons or objects are hurt or damaged in the process of testing.

**DANGER!** When folding and unfolding the boom, be sure that no persons or objects are in the operating area of the boom, and that the boom cannot touch any electrical conductors!

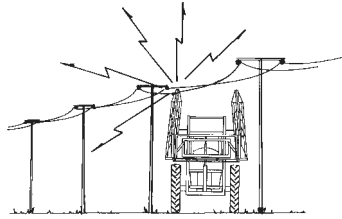

T029-0010

## The HAY boom

The boom unfolding/folding can be done according to instructions below.

1. Lift up the boom lift until the boom is clear of the transport brackets using the single acting spool valve
2. Unfold the boom completely using the double acting spool valve
3. Lower the boom to correct working height above the ground/crop 50 cm/20 in

Folding is to be done in reverse order.

## The HAZ boom

(If the sprayer is equipped with HARDI NOVA, please see separate instruction book for operating instructions).

Functions of the control box:

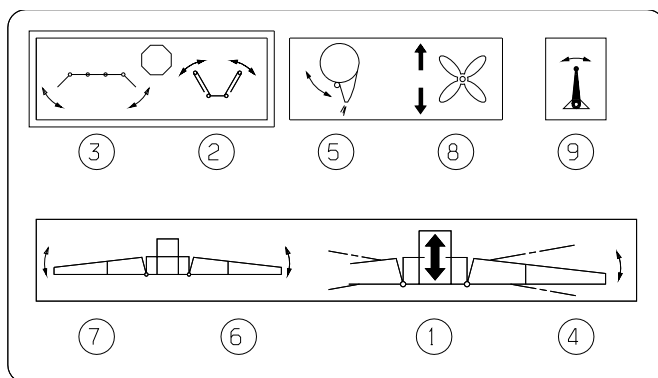

T030-0004

1. Raising and lowering of boom
2. Unfolding/folding of inner sections
3. Unfolding/folding of outer sections
4. Slanting of boom
5. Angling of air slot/nozzle assembly
6. Boom tilt, RH
7. Boom tilt, LH
8. Fan speed adjustment
9. Drawbar mode (STEER TRACK only)

The boom unfolding/folding can be done according to instructions below:

## Unfolding the boom

**NOTE!** Ensure that the transport safety chains are removed and the boom is clear from the transport brackets before unfolding.

1. Push switch **1** upwards to lift the boom clear of the transport brackets.
2. Push switch **2** upwards to unfold the inner sections. Rear transport hooks disengage automatically.
3. Push switches **6** and **7** downwards to lower individual tilt rams.
4. Push switch **3** upwards to unfold outer sections.
5. Push switch **4** to correct slant angle.
6. Push switch **1** downwards to lower the boom to correct height above crop or ground level.
7. In order to reduce wind drift and/or increase penetration of spray liquid in the crop, the slot angle can be changed backwards and forwards with switch **5**.

**IMPORTANT!** The two upper functions in the red rectangle with STOP signs must only be operated when the sprayer is stationary! Failure to do so will damage the boom.

## Folding the boom

1. Check that the slanting function is midway **4**.
2. Set slot angle at midway **5**.
3. Raise boom **1** to upper position.
4. Fold outer sections **3**
5. Lift individual boom tilt **6** and **7**
6. Fold inner sections **2**. Rear transport hooks engage automatically.
7. Lower boom **1** until boom rests on transport brackets.

## Hydraulic slanting control

The hydraulic slanting control **4** enables slanting of the entire boom hydraulically. This is advantageous when spraying across hillsides.

Reset position to neutral (midway) before folding the boom.

## Boom tilt function

The boom tilt function control **6** and **7** enables you to adjust the boom height individually in right and left-hand side.

## Air slot angling

The air slot and nozzle assembly can be angled approx. 40° forwards and 30° backwards compared to vertical position. Regarding adjustments - see section on "Air technique".

# Operation

## Electrical fan speed adjustment (if fitted)

Increasing of fan speed

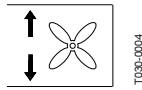

Decreasing of fan speed

8

The max. Revolutions for the fan is 3100 r.p.m., which will give full air speed of approx. 40 m/sec (90 mph).

The fan speed is indicated by the transmission working pressure by means of a pressure gauge.

Conversion table between pressure and fan speed - see section "Air Technique"

**IMPORTANT!** To avoid shock starting the fans always set fan speed to 0 before engaging the P.T.O.

## Boom support wheels

The boom is equipped with two support wheels. When spraying with low boom heights on bare ground or plants in the first growth stage it is recommended to fold down the support wheels. In later growth stages the wheels should remain folded up.

**IMPORTANT!** When driving on public roads the support wheels should be folded up and secured in order to keep the machine overall width according to the regulations!

## Boom suspension sensitivity

The boom suspension will normally suit most conditions and do not require any adjustment. The suspension will keep the boom parallel to the ground and compensate for uneven ground.

However, special conditions or situations can require the suspension to react less or more slowly.

When the RH and LH guide rods are parallel to each other (factory setting) the boom suspension will react immediately, and the boom will move independently of the trailer or tractor.

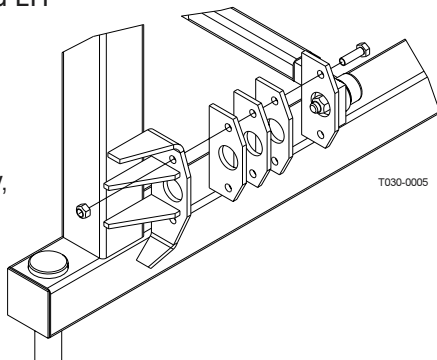

If the boom should follow the movements or inclinations of the trailer the guide rods should be inclined towards each other at the rear.

Add 1-4 pcs. of 10 mm spacers as shown at each rod until the desired function is reached.

# Operation

## Operating the liquid system MANIFOLD SYSTEM

The MANIFOLD SYSTEM is located at the left side of the sprayer and permits operation of the liquid system from one position. The modular MANIFOLD system facilitates the addition of up to two optional extras on the pressure side and one extra on the suction side.

### Function diagram - EVC (Standard)

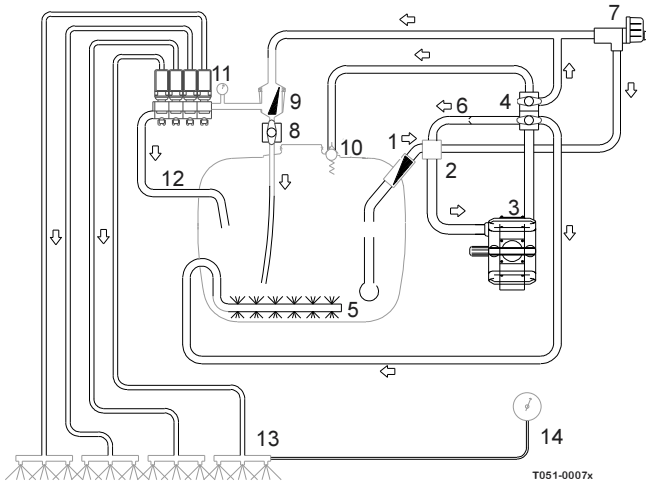

1. Suction filter
2. Suction manifold (black)
3. Pump
4. Pressure manifold (green)
5. Agitation
6. Without agitation (pressure equalisation)
7. HARDI MATIC
8. Return line (Self-cleaning filter)
9. Self-Cleaning Filter
10. Safety valve
11. Distribution valves
12. Return from Pressure Equalisation
13. Sprayer boom
14. Pressure gauge

## Use of MANIFOLD valve system

The following pictograms and colours are used for visualizing the functions of the MANIFOLD valves:

- Green disc = Pressure valve
- Black disc = Suction valve
- Yellow disc = Self-cleaning filter

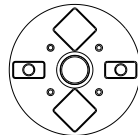

A function is activated/opened by turning the handle towards the desired function

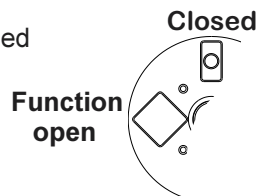

Pictograms - Green disc (pressure)	
Self-cleaning filter / Operating unit	
Fast filling device	
HARDI FILLER	
Agitation *	
Without agitation	
Tank flushing nozzle	
To main tank	
Spray gun	

026

### \*Agitation

Normally, Agitation should be on but please refer to the following rules of thumb:

1. Choose "Without Agitation" if a high level of effervescence occurs in order to reduce the amount of foam.
2. Choose "Agitation" when using powder chemicals in order to avoid sedimentation.
3. Close the valve if spraying with a high volume and it is impossible to achieve sufficient pressure.

Pictograms - Black disc (suction)	
Suction from main tank	
Rinsing tank	
Filling device	

025



# Operation

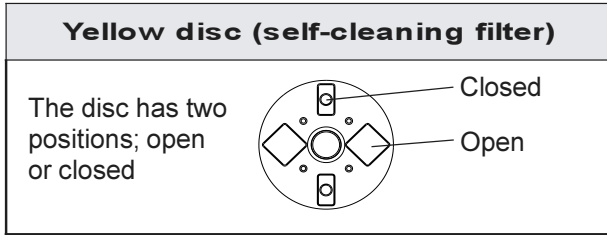

027

The valves and functions may vary from machine to machine depending on optional equipment fitted. Only the functions to be used must be open - Always close remaining valves.

## To operate the spraying functions:

- Turn the handle on a green pressure valve towards the function desired
- Turn the handle on a black suction valve towards the desired function
- Open or close yellow disc (self-cleaning filter)
- Close all remaining valves by setting the handle(s) on "O"

**NOTE!** If a MANIFOLD valve is too tight to operate - or if it is too loose (= liquid leakage), the 3-way-valve needs to be serviced. Please see the part *Occasional maintenance - Adjustment of 3-way-valve* for further information.

### Electrical operated MANIFOLD valves (if fitted)

One or more MANIFOLD valve(s) can be electrically operated via a control box in the tractor cab. These can only be operated manually when the power to the valve motor is disconnected first.

### Quick reference

A quick reference - consisting of two labels - is accompanying this book.

The labels are meant to be fitted to the frame near to the MANIFOLD SYSTEM for easy "in field" operation of the valves.

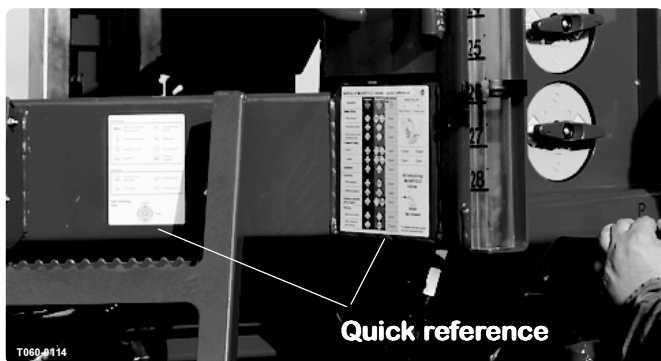

## Filling of water

Water can be filled into the main tank in five ways:

1. Filled through tank lid.
2. Filled by diaphragm pump through a suction side fitted filling device (optional extra) using normal pump capacity directly to the tank.
3. Filled by diaphragm pump through a pressure side fitted injector/venturi type Fast Filling Device (optional extra) providing up to 3 times normal pump capacity.
4. Combination of 2 and 3.
5. Quick coupler for external filling

The tank should normally be filled 1/3 with water, before adding the chemicals - always read instruction on chemical container!

**NOTE!** Max. permitted tank contents:

Model	Volume, water			Volume, liquid fertilisers*		
	Litre	Imp. gal	US gal	Litre	Imp. gal	US gal
2200 I	2200	484	580.8	2154	473.8	568.6
2800 I	2800	616	739.2	2154	473.8	568.6
3200 I	3200	704	844.8	3200	704	844.8
4200 I	4200	924	1108.8	3231	710.8	852.9

\* Based on liquid fertilisers with specific gravity 1.3 chart 022

### 1. Filling through tank lid

Remove tank lid and fill water through strainer to prevent rust or other particles to enter the tank.

An overhead tank can be used in order to obtain high filling capacity.

It is recommended to use as clean water as possible for spraying purposes.



**WARNING!** DO NOT LET FILLING HOSE ETC. ENTER THE TANK. KEEP IT OUTSIDE THE TANK, POINTING TOWARDS THE FILLING HOLE.

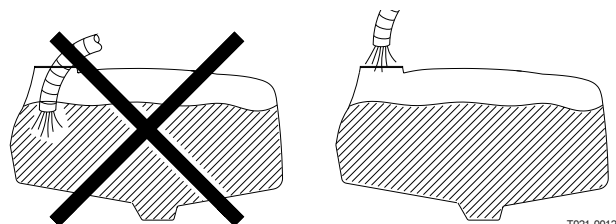

IF THE HOSE IS LEAD TO THE BOTTOM OF THE TANK, AND THE WATER PUMP AT THE WATER SUPPLY PLANT STOPS, CHEMICALS CAN BE SIPHONED BACK AND CONTAMINATE THE WATER SUPPLY LINES.

# Operation

## 2. Suction Filling Device (if fitted)



**WARNING! Avoid contamination or personal injury. Do not open suction valve towards Suction Filling Device unless pump is running and filling hose is connected. If this valve is opened without pump running, liquid will stream out of the MANIFOLD.**

The Suction Filling Device is operated as follows:

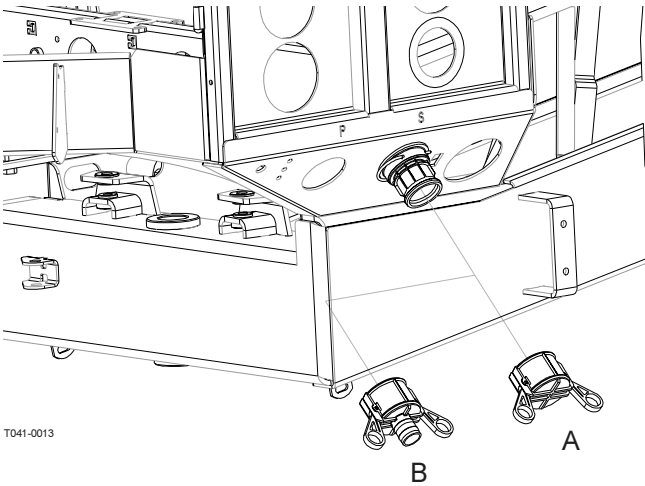

T041-0013

1. Remove cover **A**, and connect suction hose **B** to Suction Manifold.
2. Engage diaphragm pump and set P.T.O. revolutions at 540 r/min or 1000 r/min (depending on pump model)
3. Turn handle on Suction Manifold towards Filling Device.

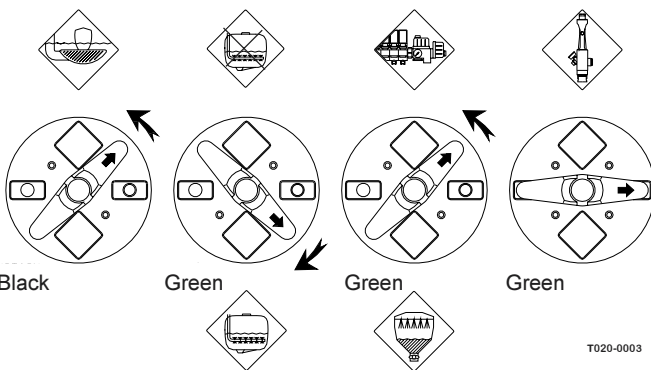

T020-0003

4. The tank is now filled with water. Keep an eye on the liquid level indicator.
5. Turn handle on Suction Manifold away from Filling Device to discontinue filling process. Then disengage pump.
6. Disconnect suction tube **B** and replace cover.

**NOTE!** Observe local legislation regarding use of Filling Device. In some areas it is prohibited to fill from open water reservoirs (lakes, rivers etc.). It is recommended

only to fill from closed reservoirs (mobile water tanks etc.) to avoid contamination.



**WARNING!** If suction hose/filter is carried on the sprayer during spraying, it can be contaminated by spray drift which will be transferred to lake/river when filling!

## 3. Fast Filling Device (if fitted)

The Fast Filling Device is operated as follows:

1. Ensure spray liquid tank contains at least 50 litres of water.
2. Remove cover (**A**) and connect suction hose (**B**).
3. Turn handle on Pressure Manifold towards Fast Filler. With the P.T.O. at 540 r/min or 1000 r/min (depending on pump model), the pressure gauge should indicate about 10 bar.
4. If water is not seen in the transfer tube, prime by turning valve (**C**).
5. Keep an eye on the liquid level indicator.
6. Turn handle on Pressure Manifold away from Fast Filler to discontinue filling process.

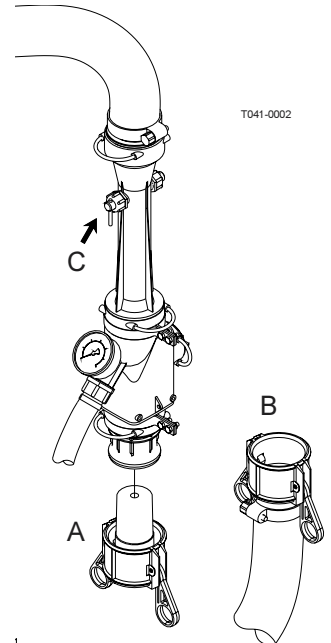

T041-0002

**NOTE:** Turn handle towards -operating unit **before** turning away from Fast Filler in order to avoid peak pressure blowing the safety valve!

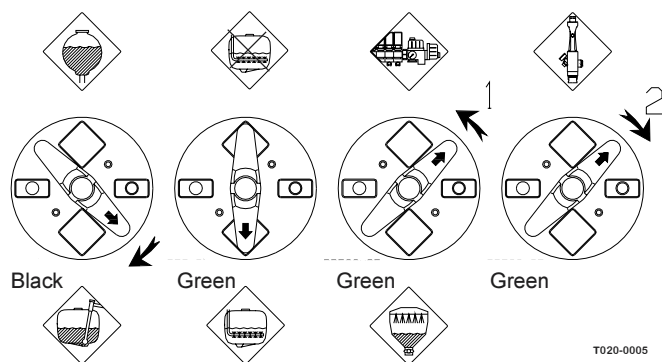

T020-0005

7. Disconnect suction tube (**B**) and replace cover.

# Operation

## 4. Filling device and Fast filling device used simultaneously

The Filling Device and the Fast Filling Device can be used simultaneously - this gives even bigger filling capacity.

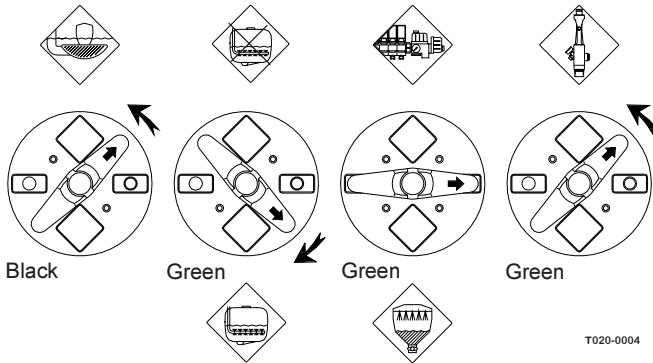

T020-0004



**WARNING:** Do not leave the sprayer whilst refilling the tank, and keep an eye on the level gauge in order **NOT** to overfill the tank!

**NOTE!** Observe local legislation regarding use of Filling Device. In some areas it is prohibited to fill from open water reservoirs (lakes, rivers etc.). It is recommended only to fill from closed reservoirs (mobile water tanks etc.) to avoid contamination.



**WARNING!** If suction hose/filter is carried on the sprayer during spraying, it can be contaminated by spray drift, which will be transferred to lake/river when filling!

## 5. Quick coupler for external filling

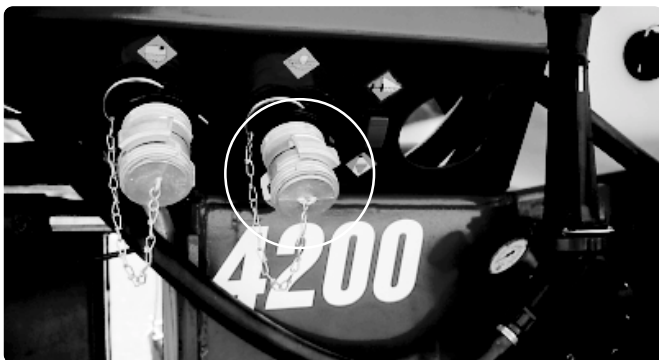

T060-0112

The quick coupler is operated as follows

1. Fit the external water hose to the quick coupler on the trailer.
2. Close self-cleaning filter.
3. Turn handle on Pressure Manifold towards Main tank.
4. Turn handle on Suction Manifold towards Filling device.

5. Depending on the chemical in question, the Pressure Manifold can be set on "Agitation". If no agitation is needed, this valve must be closed.
6. Engage the P.T.O. and start the pump.



**WARNING:** Do not leave the sprayer whilst refilling the tank, and keep an eye on the level gauge in order **NOT** to overfill the tank!

## Filling of rinsing tank (if fitted)

The rinsing tank is situated under the main tank. Only fill this tank with clean water.

The rinsing tank is filled through the inlet, situated beneath the Suction Manifold valves. Water can be filled directly through the inlet - or through a socket piece **A** (optional equipment) connected to a water hose.

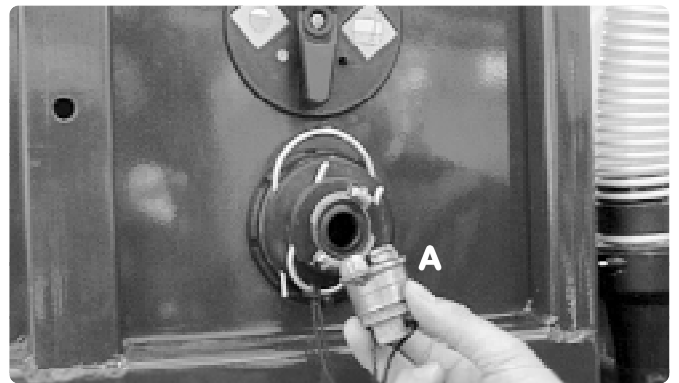

T060-0115

## Rinsing tank capacity

Model	Litre	Imp. Gal.	US Gal.
2200/2800	260	57	70
3200/4200	460	101	120

028

A water level indicator (limpid hose with floating ball) is situated beneath the platform.

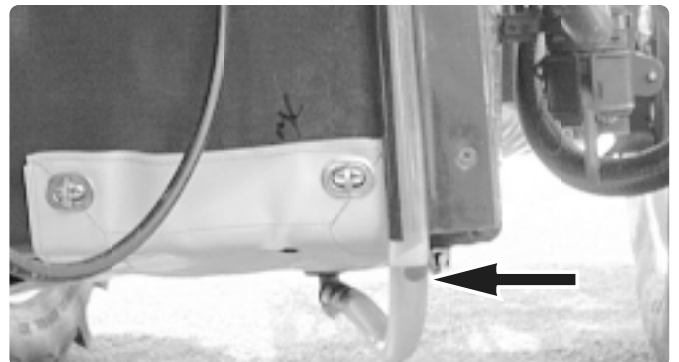

T060-0116

# Operation

## Filling of clean water tank

The clean water tank is integrated in the platform and has a capacity of 30 l. Access to the tank lid is possible from the platform. Only fill this tank with clean water from the well.

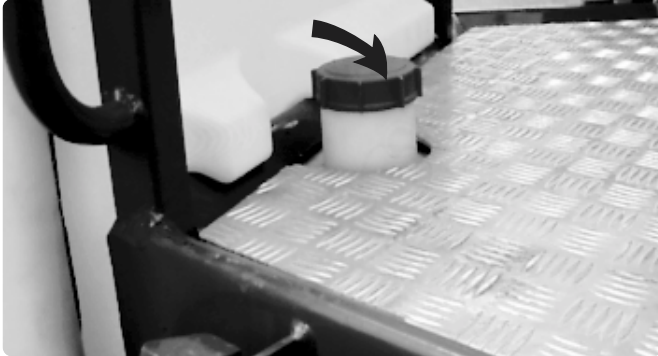

T060-0117

The water from this tank is for hand washing, cleaning of clogged nozzles etc. The tap is centrally situated in near reach from the MANIFOLD valves and is opened/closed by a handle.



**WARNING!** Although the clean water tank is only filled with clean, it must never be used for drinking.

## Adjustment of EVC operating unit

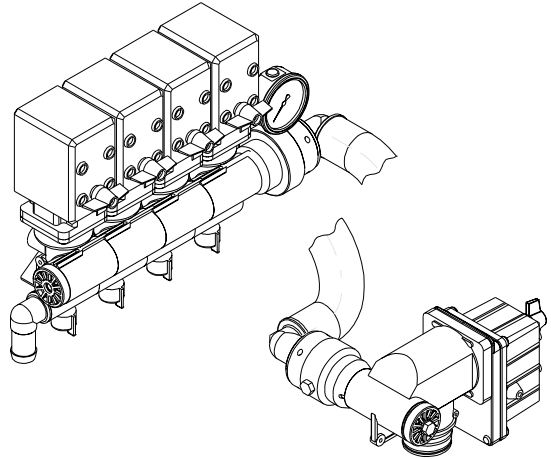

T020-0034x  
T020-0018

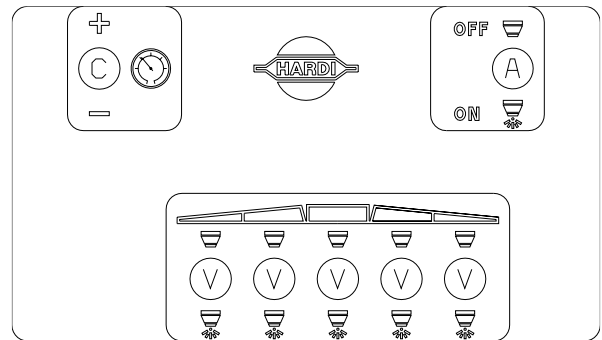

**Before spraying, the EVC operating unit is adjusted using clean water (without chemicals).**

1. Choose the correct nozzle for the spray job by turning the TRIPLET nozzle bodies. Make sure that all nozzles are the same type and capacity. See the "Spray Technique" book.
2. On-off switch **A** is activated against green.
3. All distribution valve switches **V** are activated against green.
4. Pressure regulation switch **C** is activated until emergency handle stops rotating (minimum pressure).
5. Put the tractor in neutral and adjust the P.T.O. and thereby the number of revolutions of the pump corresponding to the intended travelling speed. Remember the number of revolutions on the P.T.O. must be kept between 300-600 rpm (pump 540 r/min) or 650-1100 rpm (pump 1000 r/min).
6. Pressure regulation switch **C** is activated until the required pressure is shown on the pressure gauge.

## Adjustment of pressure equalisation

1. Close the first distribution valve switch **V**.
2. Turn the adjusting screw(s) until the pressure gauge again shows the same pressure.
3. Adjust the other sections of the distribution valve in the same way.

# Operation

**NOTE!** HEREAFTER ADJUSTMENT OF PRESSURE EQUALISATION WILL ONLY BE NEEDED WHEN:

1. YOU CHANGE TO NOZZLES WITH OTHER CAPACITIES
2. THE NOZZLE OUTPUT INCREASES AS THE NOZZLES WEAR

## Operating the control unit while spraying

In order to close the entire boom, switch ON/OFF **A** to off position. This returns the pump output to the tank through the return system.

The diaphragm Non-drip valves ensure instantaneous closing of all nozzles.

In order to close one or more sections of the boom, switch the relevant distribution valve **V** to off position. The pressure equalisation ensures that the pressure does not rise in the sections which are to remain open.

When the sprayer is put aside, the control box and the multi plug must be protected against moisture and dirt. A plastic bag may be used to protect the multi plug.

## Remote pressure gauge (if fitted)

The remote pressure gauge is integrated in the front locker. This gauge measures the working pressure in the boom tubes as close to the nozzles as possible. This pressure reading will always be slightly lower than the reading at the operating unit pressure gauge.

The outputs stated in the nozzle charts are always based on the pressure measured at the nozzle.

Always adjust pressure when calibrating and spraying according to readings at the Remote pressure gauge.



T060-0118

## Filters

All filters should always be used, and their function checked regularly. The mesh size of the filter in use should always be smaller than the flow average of the nozzles used. Therefore, pay attention to the correct combination of filters, mesh size.

## Self-cleaning filter

Operating diagram

1. From pump
2. Double filter screen
3. Guide cone
4. To operating unit
5. Replaceable restrictor
6. Return to tank
7. Screw-joint

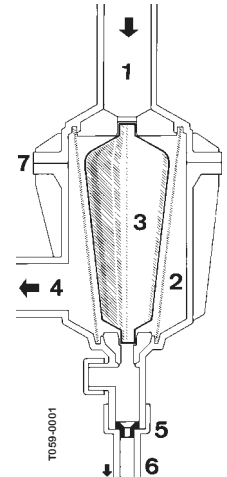

The self-cleaning filter is operated via the yellow MANIFOLD valve.

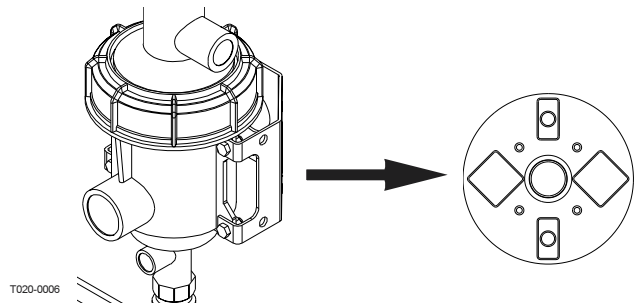

T020-0006

**IMPORTANT!** The yellow MANIFOLD valve should normally be open, but must be closed in the following cases:

1. If rinsing with water from the rinsing tank and a quantity of spray liquid still remains in the main tank (otherwise the spray liquid will be diluted).
2. If opening the self-cleaning filter and a quantity of spray liquid still remains in the main tank (otherwise there is a risk that spray liquid will flow out).

## Choice of correct restrictor

It is important to have a large flow through the filter. This is achieved by choosing the restrictor size in relation to the liquid consumption of the spray boom.

4 restrictors are supplied. Use the green one (largest orifice) first.



# Operation

The hose **N** is demounted at the self-cleaning filter, the restrictor is put in the hose and the hose is mounted again. If the required working pressure cannot be obtained, the restrictor is too large. Choose a smaller restrictor. Start with a black one, then a white and finally a red one.

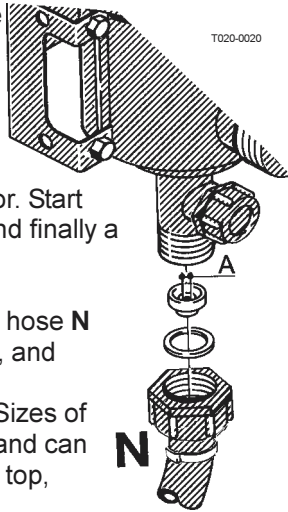

When cleaning the filter remove hose **N** and the hose at the safety valve, and check there are no residue. Standard filter size is 80 mesh. Sizes of 50 and 100 mesh are available and can be changed by opening the filter top, and replace the strainer.

Check the O-rings before reassembling the filter and replace if damaged.

## Filling of chemicals

Chemicals can be filled in the tank in two ways:

1. Through tank lid.
2. By means of HARDI FILLER chemical filling device.

### 1. Filling through tank lid

The chemicals are filled through the tank lid - Note instructions on the chemical container!



**WARNING!** Be careful not to slip or splash chemicals when carrying chemicals up to the tank lid!

1. Make sure the EVC is switched off.
2. Set the MANIFOLD valves to correct position. Black valve "Suction from main tank", green valve towards "Agitation"

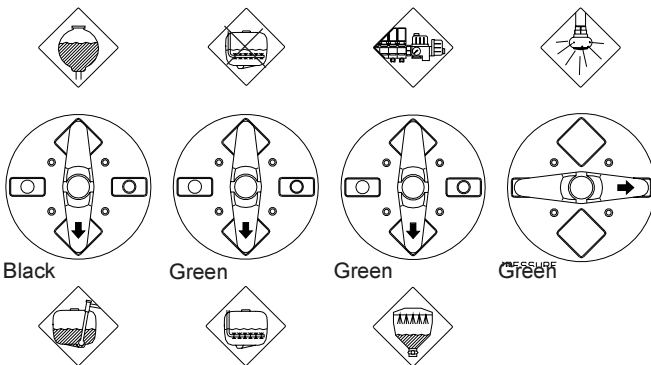

3. Engage the pump and set P.T.O. revolutions to 540 r/min or 1000 r/min (depending on pump model).

4. Add the chemicals through the main tank hole.
5. When the spray liquid is well mixed, turn handle on the Pressure Manifold towards "Spraying" position. Keep P.T.O. engaged so the spray liquid is continuously agitated until it has been sprayed on the crop.

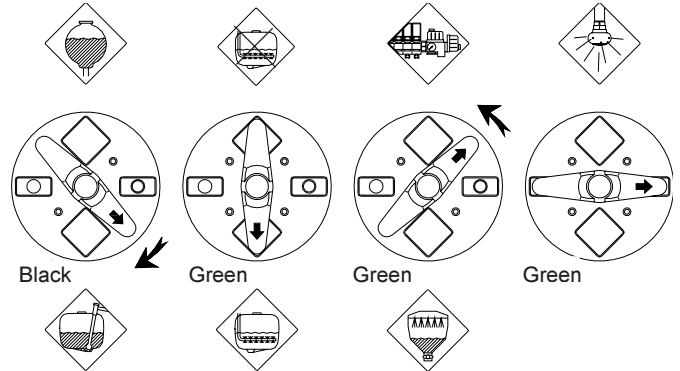

### 2. Filling by HARDI FILLER chemical inductor

To get access to the HARDI FILLER, grab the handle and drag the HARDI FILLER the whole way down. Due to the spring loaded suspension, it will stay in this position. After use, it is pushed the whole way up again.



### Filling of Liquid chemicals

1. Fill the main tank at least  $\frac{1}{3}$  with water (unless something else is stated on the chemical container label). See section "Filling of water".
2. Turn the handle at the Suction Manifold towards "Main tank". Turn green valve

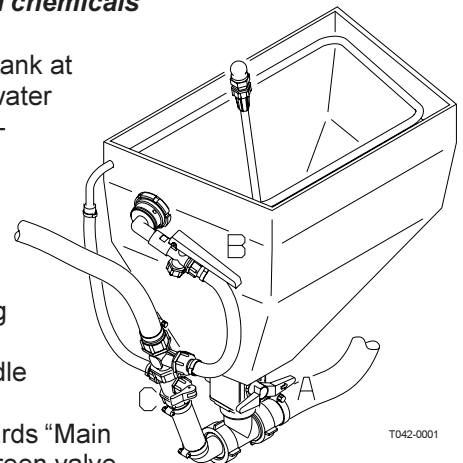

# Operation

towards "HARDI FILLER and the other green valve towards agitation. Close remaining valves.  
3. Check that bottom valve **A** at the FILLER is closed.

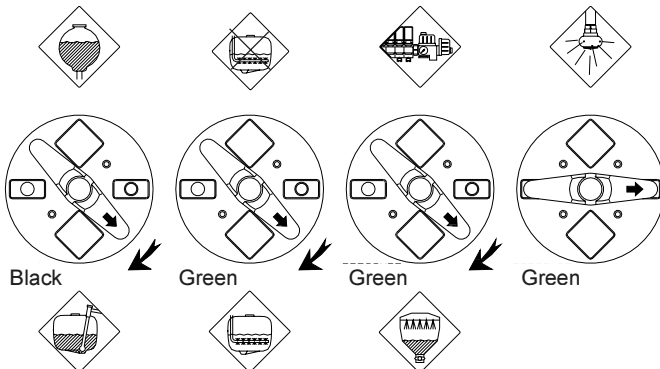

- Engage the pump and set P.T.O. speed at 540 r/min or 1000 r/min (depending on pump model).
- Open FILLER lid.
- Measure the correct quantity of chemical and fill it into the hopper.

**NOTE!** The scale in the hopper can only be used if the sprayer is parked at level ground! It is recommended to use a measuring jug for best accuracy.

- Open the bottom valve **A** and the chemical is transferred to the main tank.
- If the chemical container is empty it can be rinsed by the container rinsing device (if fitted). Place the container over the multi-hole nozzle and press the lever **B**.



**WARNING!** Do not press lever **B** unless the multi-hole nozzle is covered by a container to avoid spray liquid hitting the operator.

**IMPORTANT!** Rinsing device uses spray liquid to rinse containers for concentrated chemicals. Always rinse the chemical containers with clean water several times until they are clean before disposal.

- Engage the hopper rinsing device by opening valve **C**.
- Close valve **C** again when the hopper is rinsed.

**IMPORTANT!** The hopper rinsing device is using spray liquid for rinsing the hopper for concentrated chemical! The FILLER must always be cleaned together with the rest of the sprayer when the spray job is done.

- Close valve **A** and the FILLER lid again.
- When the spray liquid is well mixed, turn handle on the Pressure Manifold towards "Spraying" position. Keep P.T.O. engaged so the spray liquid is continuously agitated until it has been sprayed on the crop.

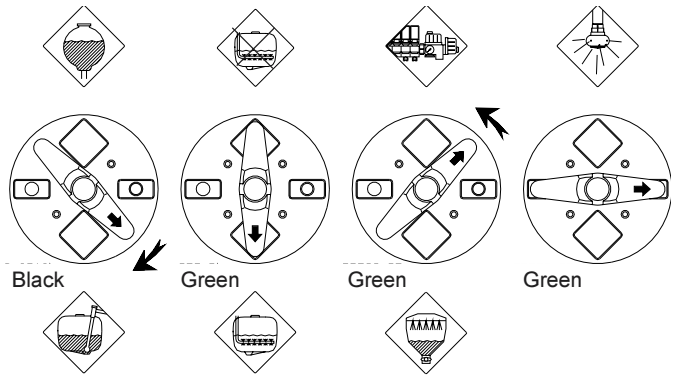

## Filling of Powder chemicals

- Fill the main tank at least  $\frac{1}{2}$  with water (unless something else is stated on the chemical container label). See section "Filling of water".
- Turn the handle at the Suction Manifold towards "Main tank" and green valve towards "Agitation". Turn the handle at the Pressure Manifold towards "HARDI FILLER". Close remaining valves.
- Engage the pump and increase P.T.O. speed to 540 r/min or 1000 r/min (depending on pump model).
- Open the bottom valve **A** at the FILLER. Open FILLER lid.
- Engage the hopper rinsing device by opening valve **C**.
- Measure the correct quantity of chemical and sprinkle it into the hopper as fast as the rinsing device can flush it down.
- If the chemical container is empty it can be rinsed by the container rinsing device (if fitted). Fit the bag bracket and place the powder bag over the multi-hole nozzle and press the lever **B**.

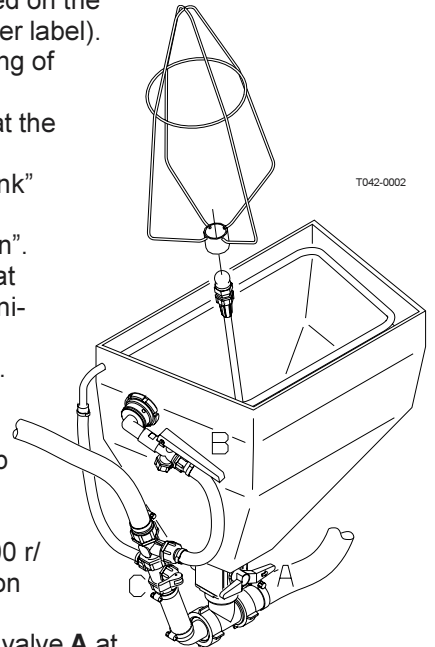

**WARNING!** Do not press lever **B** unless the multi-hole nozzle is covered by a container to avoid spray liquid hitting the operator.

**IMPORTANT!** Rinsing device uses spray liquid to rinse containers for concentrated chemicals. Always rinse the chemical containers with clean water several times until they are clean before disposal.

- Close valve **C** again when the hopper is rinsed.

# Operation

**IMPORTANT!** The hopper rinsing device is using spray liquid to rinse the hopper for concentrated chemical. The FILLER must always be cleaned together with the rest of the sprayer when the spray job is done.

10. Close valve **A** and the FILLER lid again.

11. When the spray liquid is well mixed, turn handle on the Pressure Manifold towards "Spraying" position. Keep P.T.O. engaged so the spray liquid is continuously agitated until it has been sprayed on the crop.

## Use of rinsing tank and rinsing nozzles (if fitted)

The incorporated rinsing tank can be used for two different purposes.

**A.** In-field diluting of remaining spray liquid residue in the spraying circuit for spraying the liquid in the field, before cleaning the sprayer.

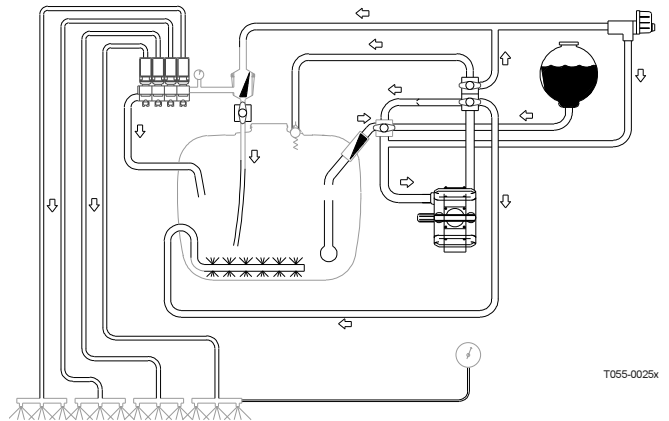

1. Empty the sprayer as much as possible. Turn the green pressure valve towards "No Agitation" and spray till air comes out of all nozzles.



2. Remove the tank filter basket.

3. Turn black suction valve towards "Rinsing tank".



4. Turn green pressure valves towards "Rinsing nozzle" (if fitted).



5. Engage and set the pump at approx. 300 r.p.m.

6. When rinsing water corresponding to approx. 10 times the spray liquid residue (see paragraph "Technical Residue") is used, turn black suction valve towards "Suction from main tank" and operate all valves, so all hoses and components are rinsed.



7. Turn green pressure valve back to "Operating unit" and spray liquid in the field you have just sprayed.



8. Repeat point 3-7 until the rinsing tank is empty.

**B.** Rinsing the pump, operating unit, spray lines, etc. in case of stop in spraying before main tank is empty (e.g. beginning rain etc.).

1. Close Self-cleaning filter (yellow valve).

2. Turn black suction valve towards "Rinsing tank".



3. Turn green pressure valve towards "No Agitation".



4. Engage the pump and spray water from rinsing tank in the field until all nozzle tubes/nozzles are flushed with



# Operation

clean water.

5. Disengage pump again.

6. Open Self-cleaning filter again.



**WARNING!** The rinsing nozzles cannot always guarantee a 100% cleaning of the tank. Always clean manually with a brush afterwards, especially if crops sensitive to the chemical just sprayed are going to be sprayed afterwards!

## Technical Residue

Inevitably a quantity of spray liquid will remain in the system. It cannot be sprayed properly on the crop, as the pump takes in air when the tank is about to be empty.

This Technical Residue is defined as the remaining liquid qty. in the system as the first clear pressure drop on the pressure gauge is read.

	Residue, litre			
	2200/2800	3200/4200	2200/2800	3200/4200
Dilutable residue <sup>1</sup>	-	-	-	-
Total residue <sup>2</sup>	-	-	-	-

024

1) Residue in main tank, possible to dilute with water from rinsing tank

2) Total residue in tank and spraying circuit on standard sprayer. Variations due to different ground inclinations etc.

The dilutable residue must be diluted 10 times with clean water and sprayed to the crop just sprayed before cleaning the sprayer - See paragraph "Cleaning".

## Draining a residue Using the drain valve

If draining a residue, e.g. liquid fertilisers into a reservoir, a snap coupler with hose can rapidly be connected to the drain valve, and the liquid can be let safely out.

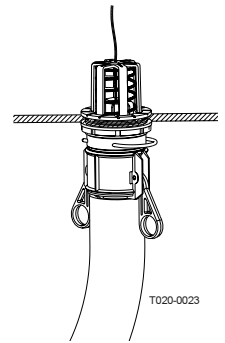

## Using the suction quick coupler

1. Connect the hose to the suction quick coupler on the trailer (pressure).
2. Turn the green valve towards "External tank".
3. Turn the black valve towards "Suction from main tank" and close Self-cleaning filter (yellow valve).
4. Engage the P.T.O to start the pump.



## Operation of the drain valves Main tank

Pull the string at left hand side of the tank to open the drain valve. The valve is spring-loaded but can be kept open by pulling the string out and upwards in the V-shaped slit.

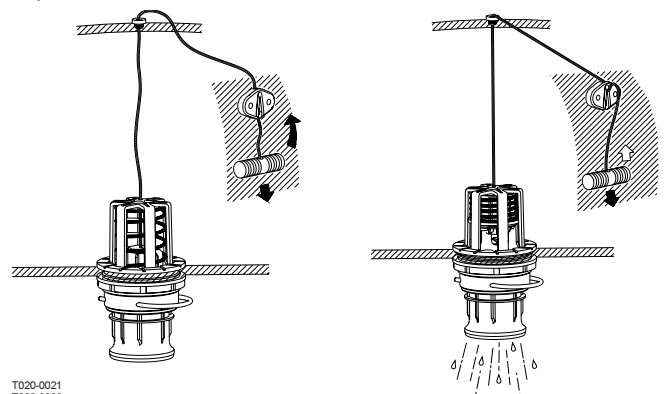

To release and close the drain valve again pull the string downwards and the valve will close automatically.

# Operation

## Rinsing tank

To avoid algae developing in the rinsing tank always drain the rinsing tank when the sprayer is not in use for a long period.

## Spray Technique - see separate book

## Safety precautions



**Always be careful when working with crop protection chemicals!**

### Personal protection

Dependant on which type of chemical used, the following protective clothing/equipment should be used:

- Gloves
- Waterproof boots
- Headgear
- Respirator
- Safety goggles
- Chemical resistant overall

This equipment should be worn to avoid contact with the chemicals.



Protective clothing/equipment should be used when preparing the spray liquid, during the spraying work and when cleaning the sprayer. Also follow the recommendations on the chemical label.



It is always advisable to have clean water available, especially when filling the sprayer with the chemical.



Always clean the sprayer carefully and immediately after use.



Do not mix different chemicals in the tank.



Always clean the sprayer before changing to another chemical.

# Air Technique

## Air technique

With TWIN air assistance energy is added to the spray droplets to improve control with the spray liquid. This way TWIN makes it possible to:

- carry the spray droplets safely to the target and increase plant deposit
- minimize off-target deposit due to wind drift or loss on the ground
- open the crop and obtain good penetration even with a low volume rate
- ensure a high coverage.

## Air speed / Air volume

The fan speed is infinitely variable and can produce from 0 to 35 m/s (78 mph) air speed at the air outlet. This equals from 0 to 2000 m<sup>3</sup> air/m boom/hour (3.872 CFM/A boom/hour). The air speed must be adjusted to the spray job

## Blower adjustment

The oil flow determines the air speed from the blowers. The oil flow can be observed on the pressure gauge (0-250 bar).

The colour codes of the gauge refer to air speed produced at certain pressure ranges.

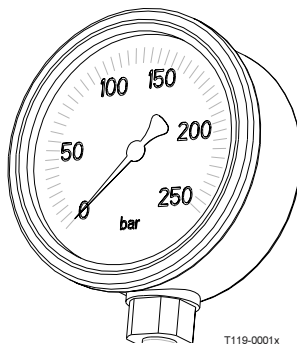

Air assistance level	Low (L)	Medium (M)	High (H)	Very high (VH)
Air speed (m/s)	5-10	10-20	20-30	30-35
Fan r.p.m.	400-1000	1000-1900	1900-2700	2700-3100
Colour code	Blue	Green	Orange	Red
Boom 18 m	20-40	40-75	75-125	125-180
Boom 20-21 m	25-50	50-90	90-150	150-200
Boom 24-28 m	30-70	70-140	140-190	190-240

Pressure in bar

018

When booms are half-folded, reduce r.p.m. or pressure with 25% to obtain the same performance.

The following table gives a rough guideline of the air assistance needed for different crop conditions.

Spray job	Air assistance
Bare ground/low vegetation/early stage row crop	Low/Medium
Spraying only the top of a crop e.g. ear spraying in wheat*	Low
Penetration in open crop*	Medium/High
Penetration in dense crop*	High/Very high

\* Can be checked with water sensitive paper

019

## Angling of air and liquid.

The main purpose of the TWIN angling system is to counteract for the negative influence which wind direction and driving speed have on the quality of the spray job. Further the "co-angling" of air and liquid can help "opening" dense crops for better penetration. The TWIN FORCE air system can be set at any angle from 40° forward to 30° back (defined by the air stream).

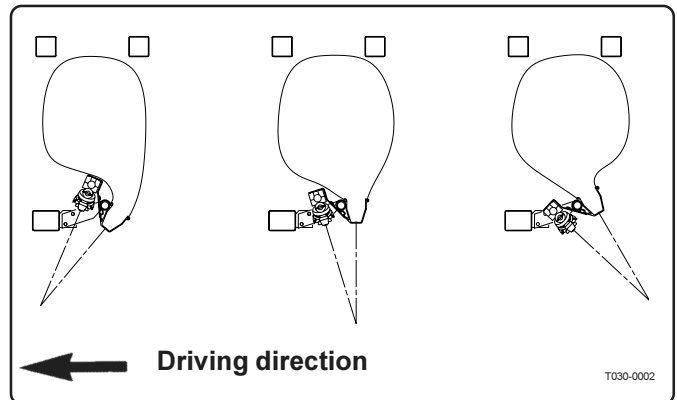

## Adjusting the air assistance

The air speed and angling must always be adjusted individually for each spray job and the given weather conditions.

It is always a good idea to get used to a new sprayer out in a field with only water in the tank, on this occasion the following routine for air adjustment should be practised:

1. Start with the air vertical
2. Set the air speed ..... **A**
3. Find the best angling ..... **B**
4. Readjust the air ..... **A**

**IMPORTANT!** Fine turning of air speed and angling will often be necessary all through the spraying job.

It is easiest to find the best air setting to reduce drift when the sun is low and behind the boom (backlight). These conditions make the drift more visible.

# Air Technique

## A Setting of air speed, rules of thumb

**Step 1:** Find the range of air speeds that can control drift:

1. Start with the air setting at zero and keep increasing the air speed just to the point where you can see that the drift cloud is minimised - note minimum setting.
2. Then increase the air speed until you see drift again - note maximum setting.
3. Now you know the range of air speeds that can be used with minimum drift.

### Bare ground / low crop

The range of air speeds is usually very small.

### Taller crop

The taller the crop the wider the range of air speeds that can reduce drift.

### At higher wind speeds

More air is needed on the sprayer and it is advisable to drive more slowly and use minimum boom height (40 cm)/(16 in).

**NOTE!** Too high air speed over bare ground/low crop can cause reflection of the spray liquid and leave dust on the leaves, which can again reduce the effect of the plant protection product.

**Step 2:** Set the optimal air speed within possible the range mentions above.

<u>Conditions</u>	<u>Air speed recommendations</u>
-------------------	----------------------------------

**Bare ground / low crop:** Use maximum air within the possible range

**Taller crop:** Deeper crop penetration requires more air on the sprayer (if you are in doubt check with water sensitive paper).

**Forward speed:** Higher forward speeds require more air on the sprayer.

**Volume rate:** Lower volume rates require more air assistance to avoid drift.

## B Angling of air and liquid, rules of thumb

To control wind drift the influence of wind speed and wind direction as well as the horizontal air current around the boom due to forward speed must be minimised. Because it is a sum of two forces with variable direction and size that we have to counteract for, the following can only be very rough guidelines.

**NOTE!** Often it will be necessary to drive with two different anglings, so the angling is changed when changing driving direction after turning at the headland.

<u>Wind direction</u>	<u>Angle / air speed</u>
-----------------------	--------------------------

**Head wind:** Angle forward

**Down wind:** Angle back (if the forward speed is higher than the wind speed: angle forward)

**Side wind / No wind:** Angle vertical or back. Only high forward speeds may require forward angling.

<u>Crop condition</u>	<u>Angle / air speed</u>
-----------------------	--------------------------

**Bare ground/ low vegetation:** Low air speed and angling back will often be the best setting to avoid reflection of spray liquid.

**Dense crop:** The angling feature is ideal to help opening the canopy and improve penetration. If you follow the crop movement as you are varying the angling you will find that at certain settings the crop will open more for penetration.

If wind speed, wind direction or for some reason forward speed changes during spraying the optimum angling is likely to change too. Be aware that with certain combinations of air speed and angling you can "close" or flatten the crop and make penetration impossible - follow the crop movement intensively especially when setting the air assistance and keep an eye on the crop all through the application.

### NOTE!

- It is most important that the sprayer operator is familiar with the above rules of thumb before using the TWIN sprayer

- All volume rates, pressures and air adjustments stated in the following tables are, of course, guiding. Special conditions regarding climate, crop quality, spraying time and applied chemical can change the procedure. The tables are showing practice in northern Europe, and conditions may be very different in other countries. If you want some local advice you are very welcome to contact the TWIN application expert at the HARDI importer or daughter company in your country

- The volume rate can generally be reduced to half of what is applied with a conventional sprayer, but with a minimum of 50-60 l/ha at 7-8 km/h (5.5-6.5 GPA at 4.5-5

# Air Technique

mph. Exceptions are of course liquid fertiliser and herbicides whose selectivity is based large droplets that will only stick to the weeds

- Low drift nozzles can also be fitted on a TWIN sprayer and help reduce drift even further
- If there is a detailed spraying instruction on the chemical label regarding drop size, spray pressure, spray volume rate etc. this should be followed. Enclose 1 bag of water sensitive paper and instruction of how to use with all TWIN sprayers.

## Water sensitive paper

USE WATER SENSITIVE PAPER TO HELP FIND THE BEST AIR SETTING.

Some time spent in different types of crops with clean water in the tank and some water sensitive paper will be valuable experience for the future work with your TWIN sprayer. The paper can be cut into smaller pieces (to simulate the target) and fixed with double sided tape at relevant places in the crop. Then spray with pure water and check the blue spots (droplets) on the paper. This way you can test different spraying techniques. Water sensitive paper is available at your local HARDI dealer, part No. 893211

Spring Barley - Tractor speed 8 km/h					
Spray task	Growth stage Feekes scale	Volume rate l/ha	Nozzle ISO	Pressure bar	Air setting
Herb. spraying	2-4	75	F-015-110	2.1	L/M
Wild oat spraying	3-5	100	F-015-110	3.6	M
1. Fungicide spraying	5-7	50	F-01-110	2.1	M
Aphids spraying	7-10.1	100	F015-110	3.6	H
Growth regulation	8-10.1	50	F-01-110	2.1	H
2. Fungicide spraying	9-10.1	100	F-015-110	3.6	H
Herb. spraying Couch grass	Latest 10 days before harvest	50	F-01-110	2.1	M/H

009

Potatoes - Tractor speed 6 km/h					
Spray task	Growth stage	Volume rate l/ha	Nozzle ISO	Pressure bar	Air setting
Herb. spraying	Pre-emergence	75	F-01-110	2.7	L
Herb. spraying	Post-emergence	75	F-01-110	2.7	L/M*
Herb. spraying	Haulm 15 cm high	75	F-01-110	2.7	M
Diseases (potatoe blight)	1. spraying latest July 1	150	F-02-110	2.6	H(VH)
Same treatment to be repeated with 10 days interval until 2 weeks before harvest					
Desiccation	When the tubers have the size required	200	F-03-110	2.1	H(VH)

011

NOTE! All volume rates, pressures and air suggestions indicated in these tables are only guiding. Special conditions regarding climate, quality of the crop, spraying time and chemicals applied (burning) may partially change the procedure.

\* NOTE! If dust is deposited on leaves the air speed must be reduced.

# Air Technique

<b>Winter Wheat - Tractor speed 8 km/h</b>					
Spray task	Growth Feekes scale	Volume rate l/ha	Nozzle ISO	Pressure bar	Air setting
Herb. spraying pre-emergence	0	75	F-015-110	2.1	L
Herb. spraying post-emergence	1-2	100	F-015-110	3.6	L/M*
Fungicide autumn	2-3	75	F-015-110	2.1	M
Herb. spraying spring	4	75	F-015-110	2.1	M
Growth regulation	4	75	F-015-110	2.1	M
Eyespot	5-6	75	F-015-110	2.1	M
1. fungicide, leaf disease	7	75	F-015-110	2.1	M
Growth regulation	8-9	75	F-015-110	2.1	M/H
1. aphids spraying	8-9	75	F-015-110	2.1	M/H
2. fungicide, leaf disease	9-10	75	F-015-110	2.1	M/H
2. aphids spraying	10-10.5	50	F-01-110	2.1	L
Fungicide, ear diseases	10-11	50	F-01-110	2.1	L
Herb. spraying Couch grass	Latest 10 days before harvest	50	F-01-110	2.1	M/H

010

<b>Rye - Tractor speed 8 km/h</b>					
Spray task	Growth stage Feekes scale	Volume rate l/ha	Nozzle ISO	Pressure bar	Air setting
Herb. spraying, residual type	0	75	F-015-110	2.1	L
Herb. spraying, post-emergence	1-2	100	F-015-110	3.6	L/M*
Autumn fungicide	2-3	75	F-015-110	2.1	M
Herb. spraying, spring	4	75	F-015-110	2.1	M
Growth regulation	5-6	100	F-015-110	3.6	M
Fungicide, eyespot	5-6	100	F-015-110	3.6	M/H
Fungicide, leaf disease	7-8	100	F-015-110	3.6	M/H
Growth regulation	8-9	75	F-015-110	2.1	M
Insecticide spraying	10-10.5	75	F-015-110	2.1	M
Herb. spraying					
Couch grass	10 days before harvest	75	F-015-110	2.1	M/H

012

NOTE! All volume rates, pressures and air suggestions indicated in these tables are only guiding. Special conditions regarding climate, quality of the crop, spraying time and chemicals applied (burning) may partially change the procedure.

\* NOTE! If dust is deposited on leaves the air speed must be reduced.

# Air Technique

Winter Rape - Tractor speed 8 km/h					
Spray task	Growth stage Feekes scale	Volume rate l/ha	Nozzle ISO	Pressure bar	Air setting
Herb. spraying	Pre-drilling	75	F-015-110	2.1	L
Herb. spraying	Post-drilling	100	F-015-110	3.6	L*
Volunteer cereal	Pre-emergence	100	F-015-110	3.6	L
Pests	At emergence	75	F-015-110	2.1	L/M*
Volunteer cereal	4 leaf stage	100	F-015-110	3.6	M
Pests	2-3 beetles/plant when in bud	75	F-015-110	2.1	M
Pests, brassica pod midge and cabbage seed weevil	Beginning of flowering	100	F-015-110	3.6	M/H
Pests	Full flowering	100	F-015-110	3.6	H
Fungicide	Full flowering and until ceasing	100	F-015-110	3.6	H/VH
Herb. spraying, couch grass + desiccation	2 weeks before harvest	100	F-02-110	2.1	H/VH

013

Peas (yellow) - Tractor speed 8 km/h					
Spray task	Growth stage Feekes scale	Volume rate l/ha	Nozzle ISO	Pressure bar	Air setting
Herb. spraying	Pre-emergence	75	F-015-110	2.1	L
Pests (pea and bean weevil + thrips)	Post-emergence	100	F-02-110	2.1	L
Herb. spraying	2-5 cm high	100	F-02-110	2.1	M
Fungicide spraying (grey mould + leaf and stem pod spot and pea weevil)	Prior to flowering	100	F-02-110	2.1	M/H
Fungicide spraying (grey mould + pea weevil)	14 days later	100	F-02-110	2.1	H
Aphids spraying	At flowering until ceasing	100	F-02-110	2.1	M
Herb. spraying, couch grass+ desiccation by systemic herbicide	2-4 weeks before harvest	100	F-015-110	3.6	H
Withering by contact herbicide	2-4 weeks before harvest	150	F-02-110	4.6	H

014

NOTE! All volume rates, pressures and air suggestions indicated in these tables are only guiding. Special conditions regarding climate, quality of the crop, spraying time and chemicals applied (burning) may partially change the procedure.

\* NOTE! If dust is deposited on leaves the air speed must be reduced.



# Air Technique

Spring Rape - Tractor speed 8 km/h					
Spray task	Growth stage Feekes scale	Volume rate l/ha	Nozzle ISO	Pressure bar	Air setting
Herb. spraying	Pre-drilling	75	F-015-110	2.1	L
Herb. spraying	Post-drilling	75	F-015-110	2.1	L
Pests	At emergence	75	F-015-110	2.1	L*
Herb. spraying broad-leaf-species	3-4 true leaves	100 <sup>1</sup>	F-02-110	2.1	L/M
Herb. spraying monocotyledonous species	4 true leaves	100	F-015-110	3.6	M
Pests, blossom beetle	1 beetle/plant when in bud	75	F-015-110	2.1	M
Pests, brassica pod midge and cabbage seed weevil	Beginning flowering	75	F-015-110	2.1	M/H
Pests, brassica pod midge and cabbage seed weevil	At full flowering	75	F-015-110	3.6	H
Fungicide	At end of flowering	100	F-015-110	3.6	H/VH
Herb. spraying, couch grass + desiccation	2 weeks before harvest	100	F-015-110	3.6	H/VH
<sup>1</sup> If applying full dose rate Benasalox (Benazolin - ethyl + Clopyralid) and Bladex (Cyanazin) in a tank mix, use water rate 150 l/ha					

014

NOTE! All volume rates, pressures and air suggestions indicated in these tables are only guiding. Special conditions regarding climate, quality of the crop, spraying time and chemicals applied (burning) may partially change the procedure.

\* NOTE! If dust is deposited on leaves the air speed must be reduced.

# Maintenance

## Maintenance - rules of thumb

In order to derive full benefit from the sprayer for many years the following service and maintenance program should be followed.

**IMPORTANT!** Always read the individual paragraphs. Read instructions for service/maintenance jobs carefully before starting on the job. If any portion remains unclear or requires facilities which are not available, then for safety reasons please leave the job to your HARDI dealer's workshop.

## Cleaning the sprayer

### Guidelines

1. Read the whole chemical label. Take note of any particular instructions regarding recommended protective clothing, deactivating agents, etc. Read the detergent and deactivating agent labels. If cleaning procedures are given, follow them closely.
2. Be familiar with local legislation regarding disposal of pesticides washings, mandatory decontamination methods, etc. Contact the appropriate department, e.g. Dept. of Agriculture.
3. Pesticide washings can usually be sprayed out on a soakaway. This is an area of ground that is not used for cropping. You must avoid seepage or runoff of residue into streams, water courses, ditches, wells, springs, etc. The washings from the cleaning area must not enter sewers. Drainage must lead to an approved soakaway.
4. Cleaning starts with the calibration, as a well calibrated sprayer will ensure the minimal amount of remaining spray liquid.
5. It is good practice to clean the sprayer immediately after use and thereby rendering the sprayer safe and ready for the next pesticide application. This also prolongs the life of the components.
6. It is sometimes necessary to leave spray liquid in the tank for short periods, e.g. overnight, or until the weather becomes suitable for spraying again. Unauthorised persons and animals must not have access to the sprayer under these circumstances.
7. If the product applied is corrosive, it is recommended to coat all metal parts of the sprayer before and after use with a suitable rust inhibitor.

### Remember:

**Clean sprayers are safe sprayers.  
Clean sprayers are ready for action.  
Clean sprayers cannot be damaged by pesticides and their solvents.**

## Cleaning the tank

1. Dilute remaining spray liquid in the tank with at least 10 parts of water and spray the liquid out in the field you have just sprayed - See paragraph "Use of rinsing tank and rinsing nozzles".

**NOTE:** It is advisable to increase the forward speed (double if possible) and reduce the pressure to 1.5 bar (20 psi).

2. Select and use the appropriate protective clothing. Select detergent suitable for cleaning and suitable deactivating agents if necessary.
3. Rinse and clean sprayer and tractor externally. Use detergent if necessary.
4. Remove tank and suction filters and clean. Be careful not to damage the mesh. Replace suction filter top. Replace filters when the sprayer is completely clean.
5. With the pump running, rinse the inside of the tank. Remember the tank roof. Rinse and operate all components and any equipment that has been in contact with the chemical.

Before opening the distribution valves and spraying the liquid out, decide whether this should be done in the field again or on the soakaway.

6. After spraying the liquid out, stop the pump and fill at least  $\frac{1}{5}$  of the tank with clean water. Note that some chemicals require the tank to be completely filled. Add appropriate detergent and/or deactivating agent, e.g. washing soda or Triple ammonia.

**NOTE!** If a cleaning procedure is given on the chemical label, follow it closely.

7. Start the pump and operate all controls enabling the liquid to come in contact with all the components. Leave the distribution valves until last. Some detergents and deactivating agents work best if left in the tank for a short period. Check the label. The Self-Cleaning Filter can be flushed by removing the by-pass hose from the bottom of the filter. Stop the pump and remove the hose. Start the pump for a few seconds to flush filter. Be careful not to lose the restrictor nozzle.
8. Drain the tank and let the pump run dry. Rinse inside of the tank, again letting the pump run dry.
9. Stop the pump. If the pesticides used have a tendency to block nozzles and filters, remove and clean them now. Also check for sediment on the pressure side of the safety valve for the Self-Cleaning Filter.

# Maintenance

---

10. Replace all the filters and nozzles and store the sprayer. If, from previous experiences, it is noted that the solvents in the pesticide are particularly aggressive, store the sprayer with the tank lid open.

**NOTE!** If the sprayer is cleaned with a high pressure cleaner lubrication of the entire machine is recommended.

## **Cleaning and maintenance of filters**

Clean filters ensure:



- Sprayer components such as valves, diaphragms and operating unit are not hindered or damaged during operation.
- Nozzle blockages do not occur whilst spraying.
- Long life of the pump. A blocked suction filter will result in pump cavitation.

The main filter protecting sprayer components is the suction filter at the top of the tank. Check it regularly.

# Maintenance

## Lubrication

Recommended lubrication is shown in this table.

Lubricating points		Lubricant	
Ball bearings		<b>A</b>	Universal Lithium grease, NLGI No. 2 SHELL RETINAX EP2 CASTROL LMX GREASE
Slide bearings		<b>B</b>	Lithium grease with Molybdenumdisulphide or graphite SHELL RETINAX HDM2 CASTROL MOLYMAX
Oil lub. points		<b>C</b>	TOTAL Transmission TM SAE 80W/90 CASTROL EPX 80W/90 SHELL SPIRAX 80W/90 MOBIL MOBILUBE 80W/90
Hydrostatic fan transmission			Hydraulic oil type ISO HV 68 SHELL TELLUST T 68 CASTROL HYPIN AWH 68 TEXACO RANDO OIL 68
Gear box			Engine or universal oil SAE 15W40

Always store lubricants clean, dry and cool - preferably at a constant temperature - to avoid contamination from dirt and condensed water.

Keep oil filling jugs, hoppers and grease guns clean, and clean the lubricating points thoroughly before lubricating.

Avoid skin contact with oil products for longer periods.

**NOTE!** If the sprayer is cleaned with a high pressure cleaner or fertiliser has been used, lubrication of all sections is recommended.

## Lubricating points

### Boom

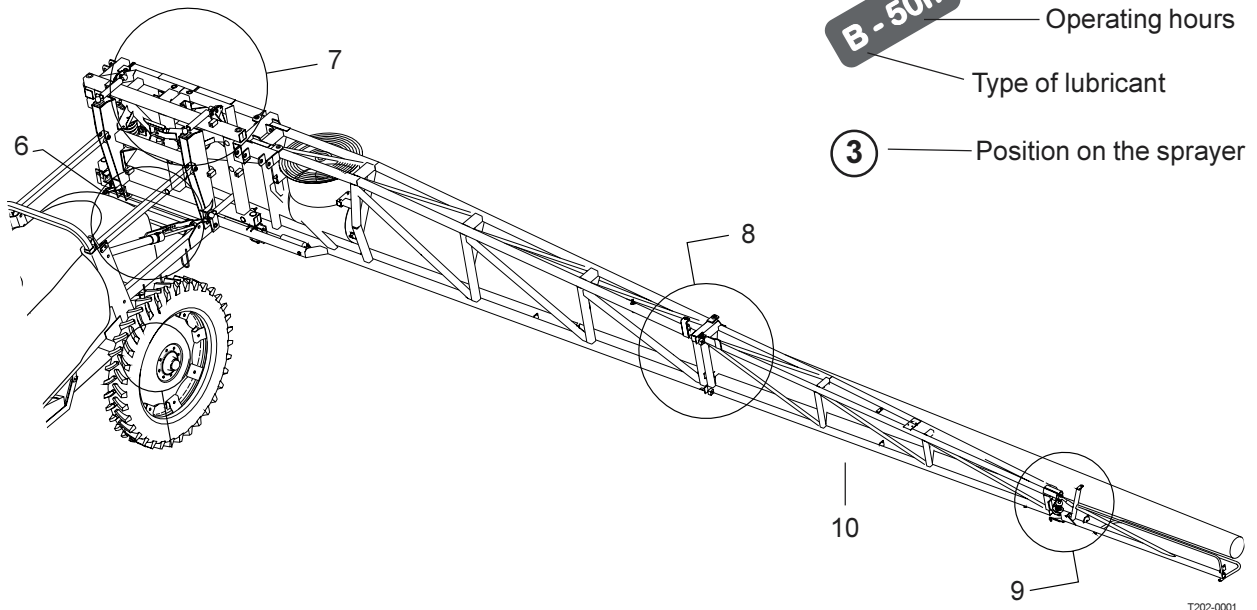

### Trailer

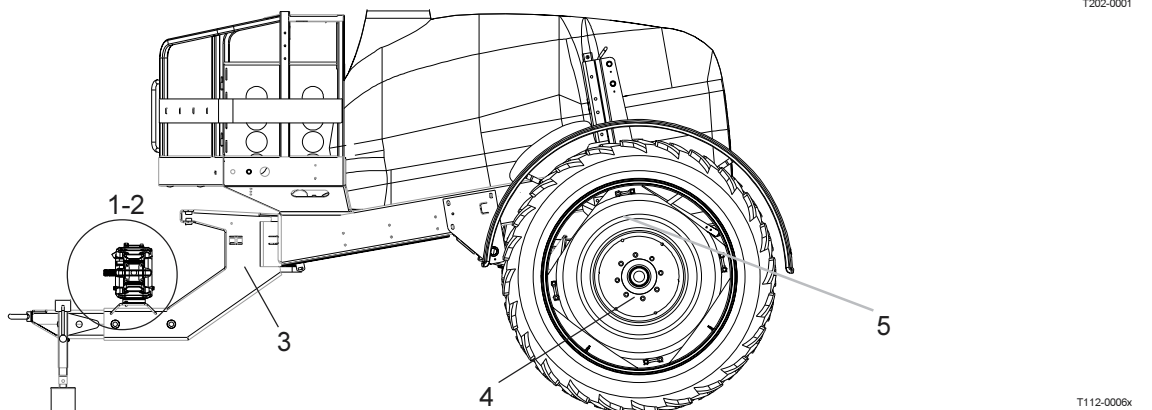

# Maintenance

1

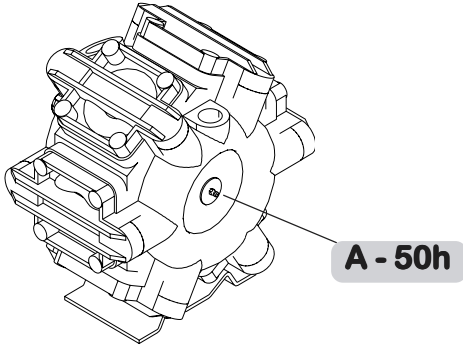

3 All models

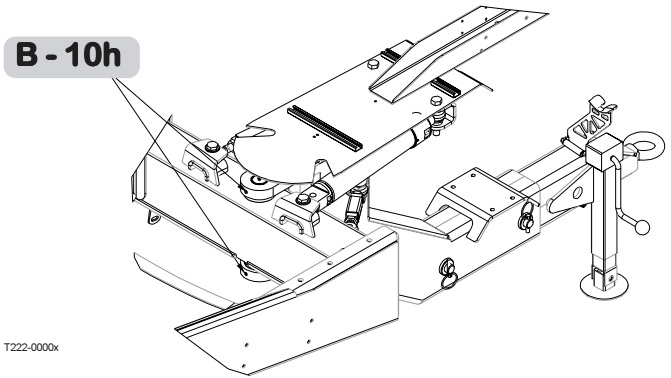

1 Double pump (HCFS only)

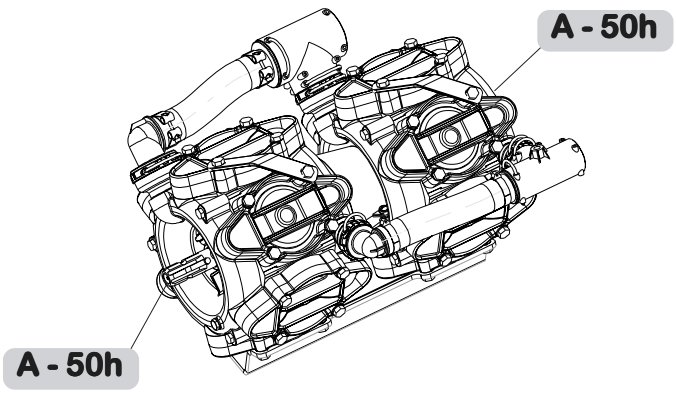

4

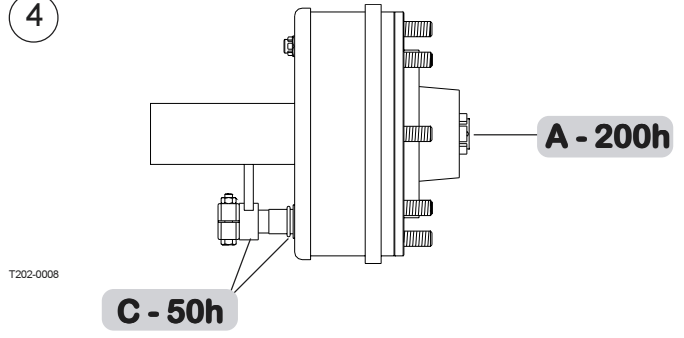

2

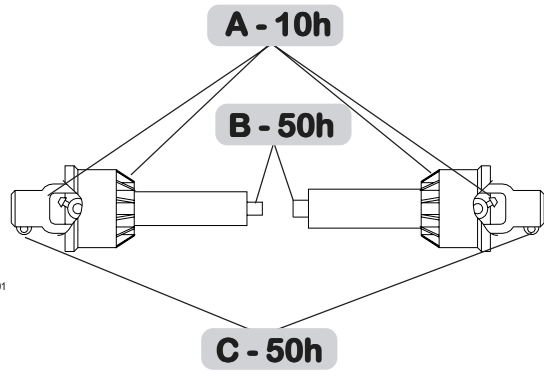

# Maintenance

## 5 Without suspension

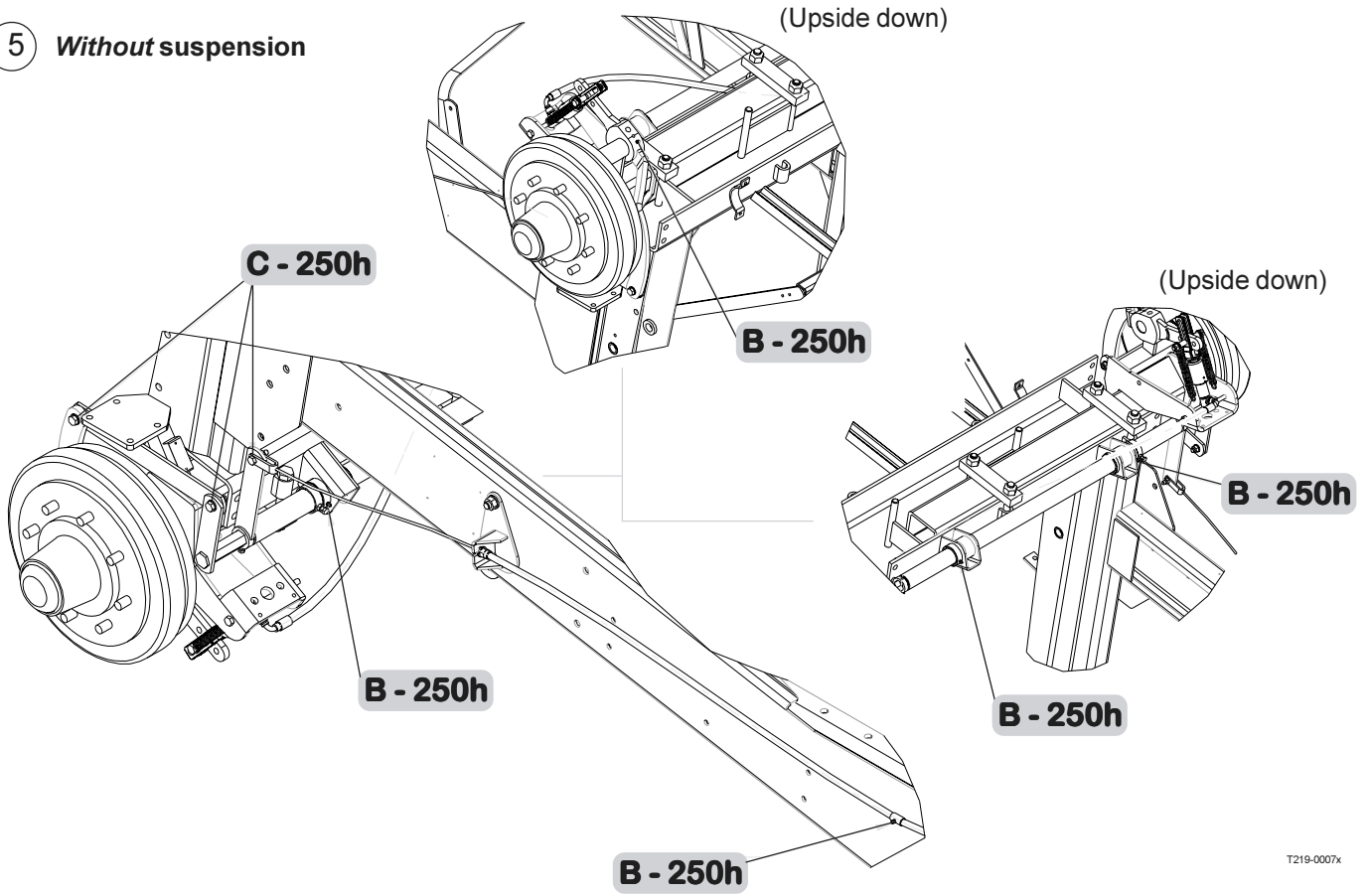

## 5 With suspension

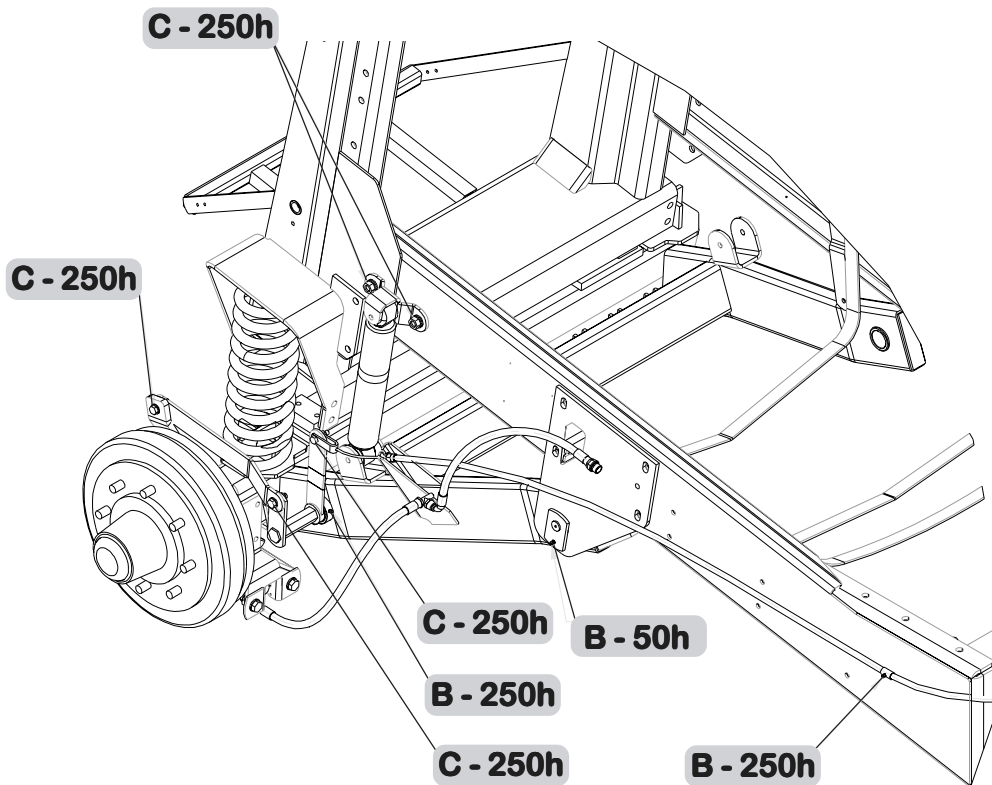



# Maintenance

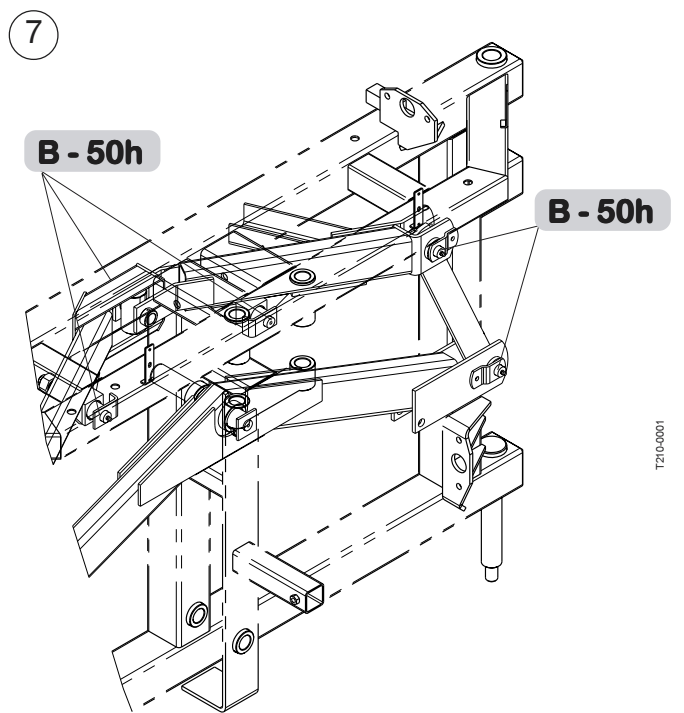
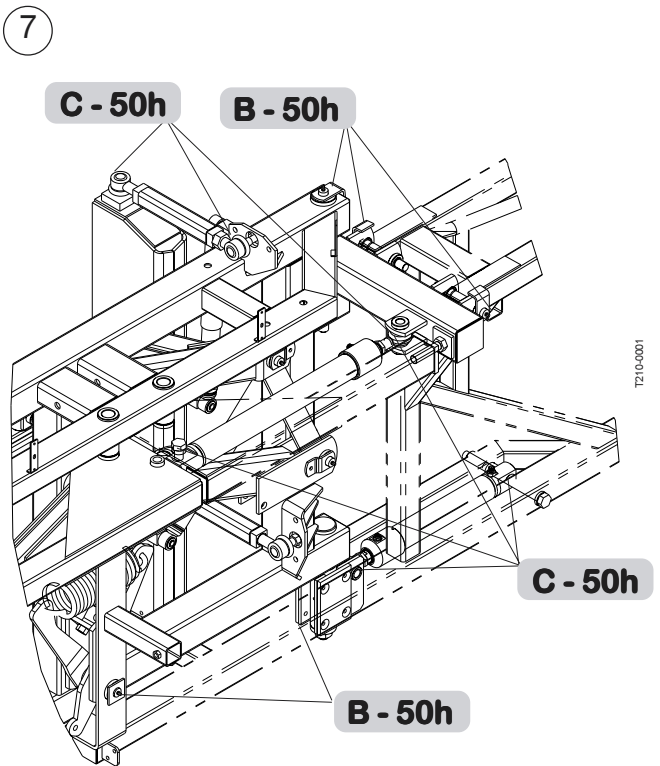
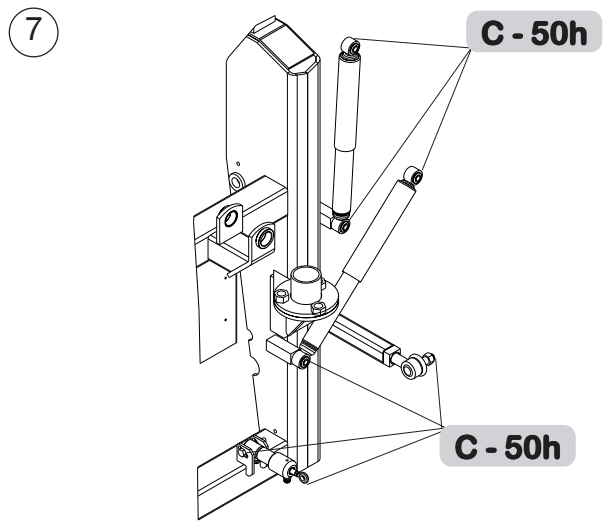
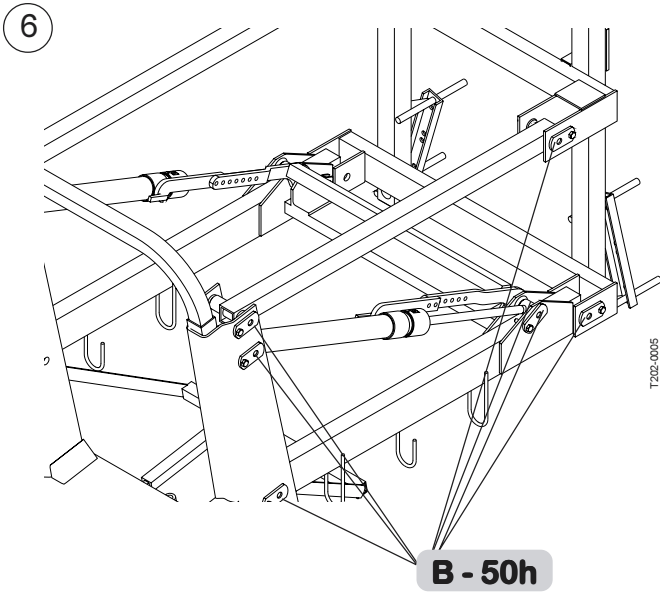

# Maintenance

8

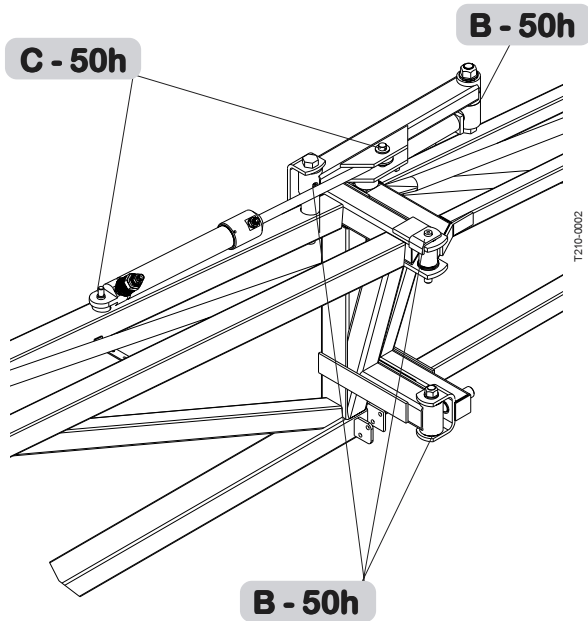

T210-0002

10

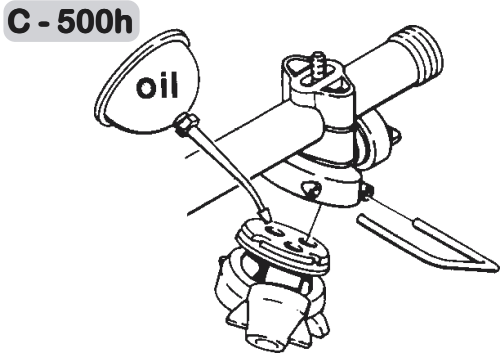

T219-0003

9

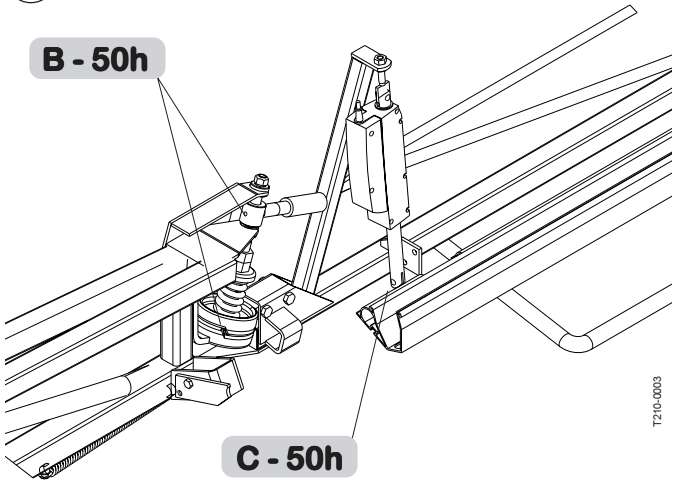

T210-0003

# Maintenance

---

## Service and Maintenance intervals

### 10 hours service

1. Suction filter, clean
2. Self-cleaning filter, check and clean
3. In-line filters, clean
4. Nozzle filters, clean
5. Spraying circuit, check for leaks
6. Brakes Air tank, drain
7. Brakes, check
8. Hydraulic oil level, check
9. Gear box oil level, check
10. Retighten bolts (suspension only)

### 50 hours service

Do all previous mentioned +

1. Wheel bolts and nuts, tighten
2. Air brakes, check
3. Expansion bottle (SELF TRACK only), check air pressure
4. Transmission shaft, check
5. Tyre pressure, check
6. Gear box bolts, check

### 100 hours service

Do all previous mentioned +

1. Fixed drawbar, check/adjust

### 250 hours service

Do all previous mentioned +

1. Wheel bearings, check
2. Parking brake, inspect
3. Wheel brake, adjust
4. Air brake filters, clean
5. Hydraulic brakes, inspect
6. Hydraulic circuit, check
7. Expansion bottle (SELF TRACK only), check oil level
8. Hoses and tubes, check
9. Readjustment of the boom

### 500 hours service

Do all previous mentioned +

1. Hydraulic oil filter, change

# Maintenance

## 1000 hours service or yearly, whichever comes first

Do all previous mentioned +

1. Wheel bearings and brakes, check
2. Transmission shaft, change parts
3. Hydraulic oil, change
4. Gear box oil, change
5. Hydraulic tank air filter, change

## Occasional maintenance

Pump valves and diaphragms renewal  
Cone check/renewal, EVC operating unit  
Cone check/renewal, EVC distribution valve  
Wear bush renewal, boom lift  
Wear bush renewal, drawbar  
Venting the hydraulic damping system (SELF TRACK)  
TRACKER damper pressure setting (SELF TRACK)  
Shock absorbers, inspect  
Level indicator adjustment  
Cord renewal, level indicator  
Seal renewal, drain valve  
Nozzle tubes and fittings  
Adjustment of 3-way-valve  
Change of bulbs  
Adjustment of slanting control indicator cable  
Transmission shaft, shield renewal  
Constant velocity joint shielding  
Change of tyres  
Fan speed adjustment  
Fan transmission priming  
Fan transmission pressure adjustment



**Always check that all lock nuts are tight after adjustment**

# Maintenance

## 10 hours service

### 1. Suction filter

To service the suction filter:

1. Pull the steel clip **A** out.
2. Lift the suction hose fitting **B** from housing.
3. Filter guide and filter **C** can now be removed.

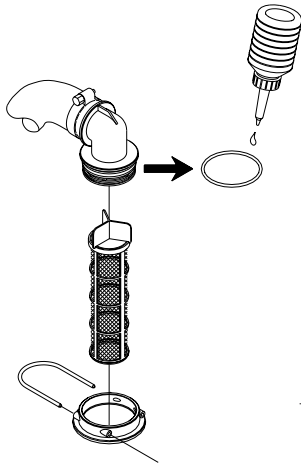

To reassemble:

4. Press the guide onto filter end.
5. Place the filter into housing with guide facing up.
6. Ensure the O-ring **D** on the hose fitting is in good condition and lubricated.
7. Refit the suction hose **B** and steel clip **A**.

T180-0003

### 2. Self-Cleaning Filter

1. Unscrew nut **A** and open filter.
2. Check filter gauze **B**, clean if necessary
3. Lubricate O-ring **C**
4. Assemble filter again.

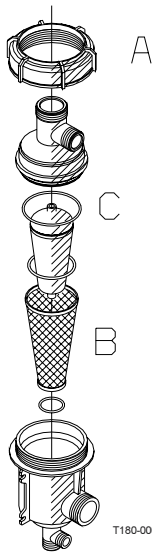

T180-0004

### 3. In-Line filter (if fitted)

If the boom is equipped with In-Line Filters unscrew the filter bowl to inspect and clean the filter.

Alternative filters are available. See section on Technical specifications - Filters and nozzles.

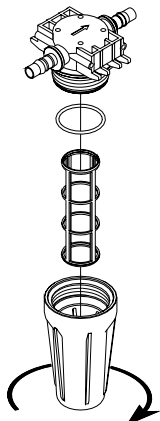

T180-0005

### 4. Nozzle filters

Check and clean.



T180-0006

### 5. Spraying circuit

Fill with clean water, operate all functions and check for leaks, use higher spray pressure than normal. Check nozzle spray patterns visually using clean water.

### 6. Brakes Air tank

Drain the air tank for condensed water at the drain valve.

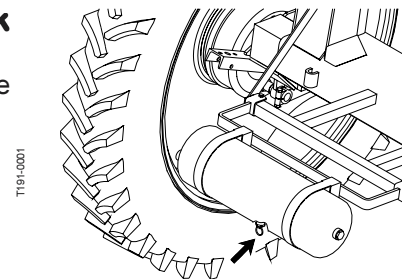

T181-0001

### 7. Brakes

Apply brake pedal and check function of trailer brakes.

### 8. Hydraulic oil level

Check that the oil level is between min. and max. on the sight glass. Clean the area around the filling cap carefully and add fresh, clean oil if the level is low. Regarding oil quality - see section the section "Lubricants".

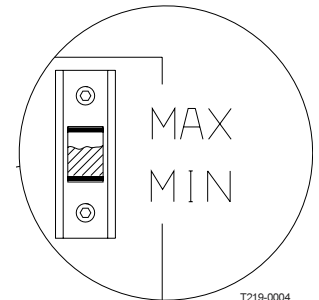

T219-0004

### 9. Gear box oil level

Check the gear box oil level is reaching the sight glass.

Clean the area around the filling plug and add fresh, clean oil if the level is low. Regarding oil quality - see the section "Lubricants"

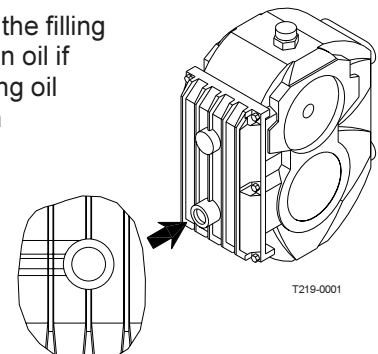

T219-0001

# Maintenance

## 10. Retighten bolts (suspension only)

Check that these 9 bolts - on each side of the COMMANDER - are tight. Retighten if necessary. Tightening torque: Bolt 1 = 24 Nm (retain nut on the backside of the mounting by a spanner while adjusting bolt 1).

Bolt 2-9: 280 Nm

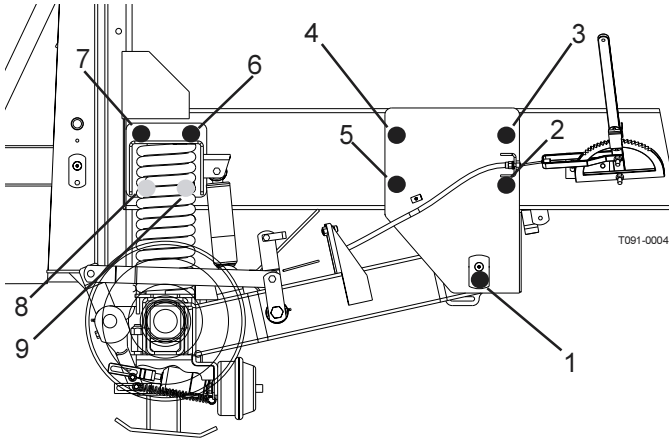

Bolt 8 and 9 are situated behind the spring.



# Maintenance

## 50 hours service

### 1. Wheel bolts and nuts

Tighten wheel bolts and nuts as follows with following torque wrench settings:

Wheel hub to rim plate:  
490 Nm (362 lbft)

Rim plate to rim:  
280 + 30 Nm  
(207 + 22 lbft)

Tightening sequence:  
See illustration.

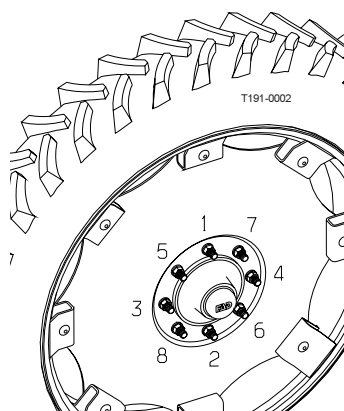

### 2. Air brakes

The air brakes are checked for leaks by following procedure:

1. Connect the snap-couplers to the tractor and fill the trailer air tanks.
2. Check for leaks with brakes released.
3. Apply the brake up to full pressure.
4. Check for leaks with brakes applied.

### 3. Expansion bottle (SELF TRACK only)

Check air pressure in the expansion tank for the hydraulic damping at the pressure gauge.

Fill through valve **A** if necessary.

Air pressure: 5 bar (73 p.s.i.)

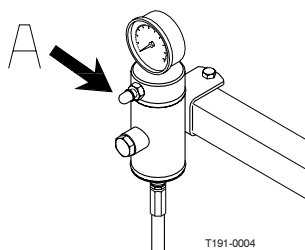

### 4. Transmission shaft

Check function and condition of the transmission shafts protection guards. Replace possible damaged parts

## 5. Tyre pressure

Check the tyre pressure according to the table below.

Tyre size RC 95	Recommended inflation pressure in bar (p.s.i.)	Minimum Load Index A8/A2
230/95 R44 (9.5 x 44)	3.6 (52)	134/145
230/95 R48 (9.5 x 48)	3.6 (52)	136/147
270/95 R44 (11.2 x 44)	3.6 (52)	140/151
270/95 R48 (11.2 x 48)	3.6 (52)	142/153
12.4 x 46	3.6 (52)	147/158
16.9 x 38	1.6 (23)	141/152
18.4 x 38	1.6 (23)	147/144
20.8 x 38	1.2 (18)	154/151

002

**IMPORTANT!** If renewing tyres always use tyres with min. load index as specified in the table.



**WARNING!** Never inflate tyres more than to the pressure specified in the table. Over-inflated tyres can explode and cause severe personal injuries! See paragraph "Tyre safety".

### 6. Gear box bolts

Check/retighten the gear box housing bolts to the specified torque.

70 Nm (51 lbft).

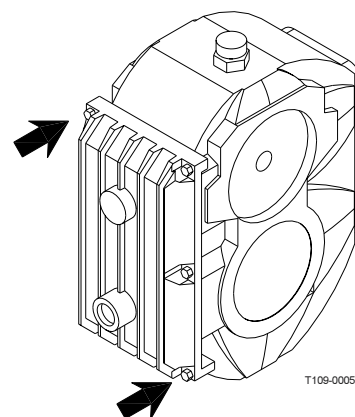

# Maintenance

## 100 hours service

### 1. Check/adjust drawbar (Fixed drawbar only)

If too much play is found in the lateral movements of the drawbar it must be adjusted.

Regulate on the turnbuckles **A** on each side in order to adjust and centre the drawbar.

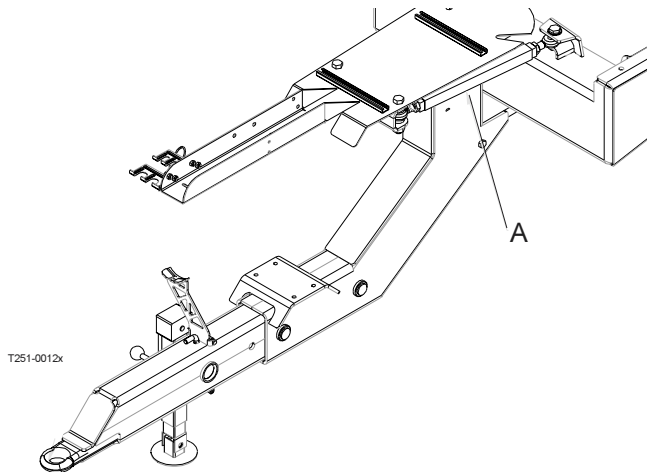

# Maintenance

## 250 hours service

### 1. Wheel bearings

Check for play in the wheel bearings:

1. Place stop wedges in front of and behind LH wheel and jack up RH wheel
2. Rock the RH wheel to discover possible play in the bearings.
3. If any play, support the wheel axle to prevent the trailer from falling down from the jack.
4. Remove hub cap **A** and cotter pin **B**. Turn the wheel and tighten the castellated nut **C** until a slight resistance in the wheel rotation is felt.
5. Loosen the castellated nut until the first notch - horizontal or vertical - is aligned with the cotter pin hole in the shaft.
6. Fit a new cotter pin and bend it.
7. Fill the hub cap with fresh grease and press it on to the hub again.
8. Repeat the procedure on LH wheel.

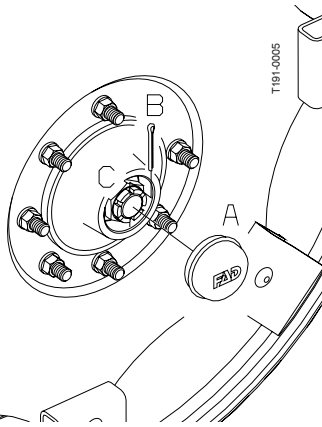

### 2. Inspect parking brake

Inspect the following:

#### The parking brake lever:

If it can be pulled further backwards than 90° (midway), using a traction of approximate 25 kg., the cable needs to be adjusted.

#### The parking brake cable:

When the parking brake is relieved, the cable must be limp; otherwise it needs to be adjusted.

Correct length: When the brake is relieved the cable must be tight and yet not stretched.

Lengthening/shortening of the parking brake cable is carried out by adjusting the nut **A**.

Inspect the parking brake cables for possible wear or damages. Replace worn or damaged parts.

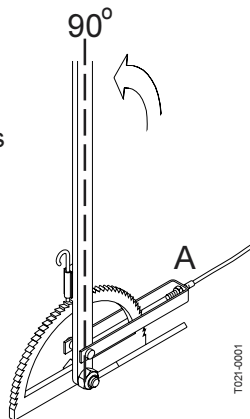

### 3. Brake adjustment

Lift the back of the COMMANDER from the ground. It is recommended to use two lifting jacks, placed underneath the axle. Make sure the COMMANDER is stable and secured before carrying out any adjustments.

1. Place the handbrake in the first jag. (Please refer to illustration).

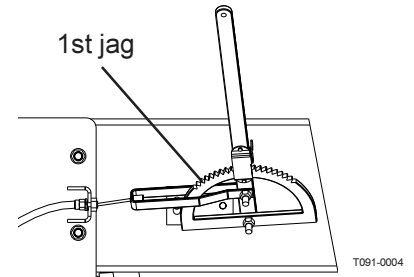

**NOTE!** The following adjustment must be carried out simultaneously on both brakes. Therefore, alternately adjust on both LH brake and RH brake.

2. Loosen nut **B**, lift and flip the small lock plate aside.
3. Adjust the nut **A** clockwise. Turn the nut 90° (1/4 turn) at a time - alternately on both LH and RH brake.

After each 1/4 turn:

Check the hub by rotating it. Continue adjustment till resistance occurs. This adjustment is completed, when each hub is strained.

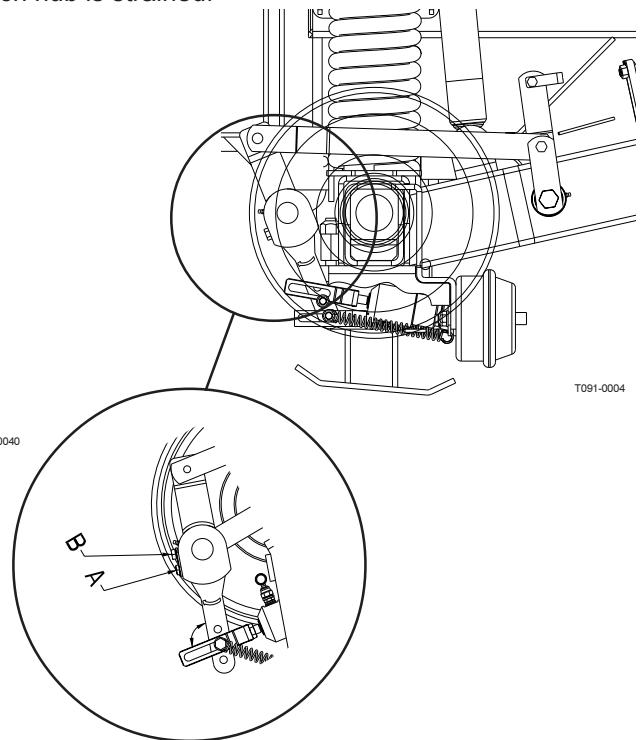

# Maintenance

## 4. Air brake filters (if fitted)

1. Clean the area around air filter(s) and disconnect air hose from the tractor.
2. Hold one hand under the filter housing, and pull out the retainer clip **A**. The filter cartridge assembly will be pushed out by the springs inside the filter housing.
3. Clean the filter cartridge. Use water and an appropriate detergent or compressed air.
4. Dry the parts and reinstall in the order shown. The O-ring should be lightly lubricated with silicone grease before installation.

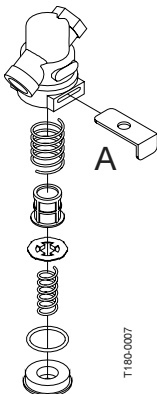

## 9. Readjustment of the boom

Please see next page.

## 5. Hydraulic brakes

Apply brakes to full pressure and inspect brake lines for damages or leaks. Replace damaged parts.

**IMPORTANT!** If the hydraulic brake lines have been dismantled the circuit must be primed afterwards:

1. Loosen brake hose at both brake cylinders.
2. Apply brake until oil without air bubbles come out.
3. Tighten brake hose before relieving the brake again.

## 6. Hydraulic circuit

Check the hydraulic circuit for leaks and repair if any.

## 7. Expansion bottle (SELF TRACK only)

Check the oil level:

1. Depressurize the expansion bottle through valve **A** first.
2. Remove the level plug **B** and check that the oil level is reaching the level hole. Add if the level is low.
3. Tighten the plug again and inflate the bottle to 5 bar air pressure.

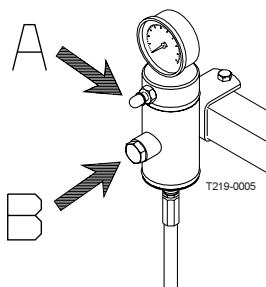

## 8. Hoses and tubes

Check all hoses and tubes for possible damages and proper attachment. Renew damaged hoses or tubes.

# Maintenance

## Boom readjustment

1. Park the sprayer on a level surface
2. Unfold the boom completely
3. Lower tilt rams completely
4. Set the slanting control midway (piston rod length is 60 mm)

Following adjustments can now be carried out:

### Suspension spring tension

1. Loosen the counter nuts **A** in either side and adjust the tension of the vertical springs on the bolts **B** to suit the boom weight. The adjustment is correct when the guide rods are approximately level.
2. Tighten the counter nuts again.

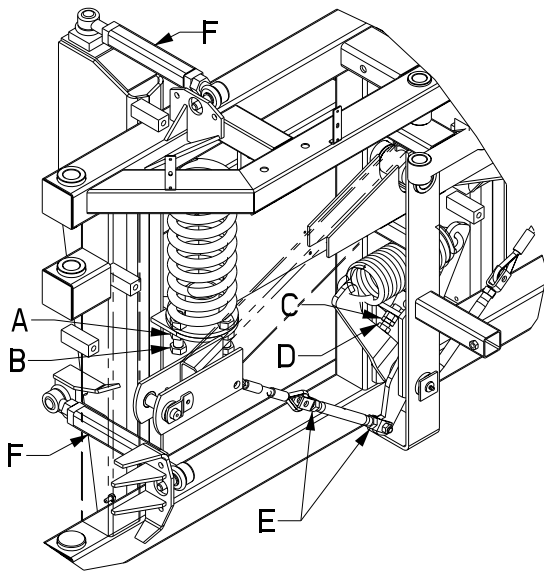

T100-0001

### Pendulum return spring and cables

1. Ensure that the slanting ram is set midway
2. Loosen the counter nuts **C** and adjust the stop screws **D** until the V-shaped mechanism is in symmetry.
3. Allow max. 1 mm play between stop screw and arm.
4. Loosen the counter nuts **E** on the rigging screws, and adjust the length of the rigging screws until the boom is level. The correct adjustment is reached when the spring opens 1 mm between the threads
5. Tighten the counter nuts again.

### Guide rods length adjustment

The guide rods length should normally not be necessary to adjust. If the suspension has been dismantled, the length must be checked or adjusted if necessary.

The trapeze and pendulum must hang freely. Adjust the length of the rods **F** accordingly.

Loosen the counter nuts and adjust the rods.

## Inner section folding adjustment

The boom tip must point slightly forward. If necessary adjust the inner section folding as follows:

1. Depressurize the folding rams
2. Loosen counter nut **A**
3. Adjust stop screw **B** until the correct setting is reached.
4. Tighten counter nuts again

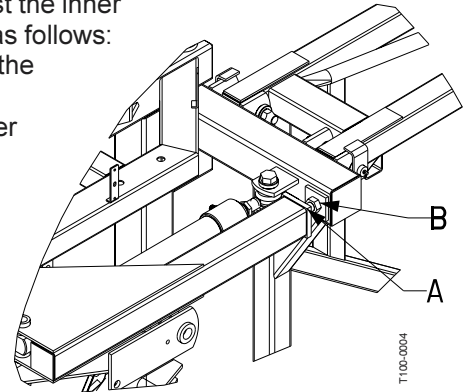

T100-0004

## Outer section folding adjustment

The outer sections must be aligned with the inner sections. If necessary adjust the outer sections as follows:

1. Depressurize the folding rams
2. Loosen counter nuts **A** and **C**.
3. Loosen the screws **B**.
4. Pressurize the folding ram until it is fully extended.
5. Adjust on the rigging screw **D** until the correct setting is reached.
6. Adjust the stop screws **B** up against the inner section.
7. Tighten counter nuts again

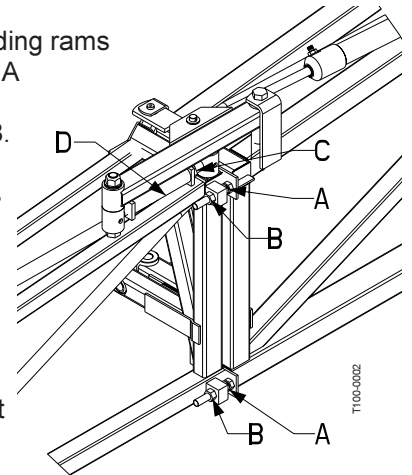

T100-0002

## Breakaway section adjustment

The breakaway section must release when a force of approximately 150 N (34 lb) is applied to the extremity of the breakaway section. If necessary the release force is adjusted as follows:

1. Make sure the claw coupling is correctly lubricated.
2. Loosen the counter nut **A**
3. Adjust the nut **B** until the breakaway will release at a force of 150 N (34 lb) applied at the extremity of the section.
4. Tighten the counter nut again.

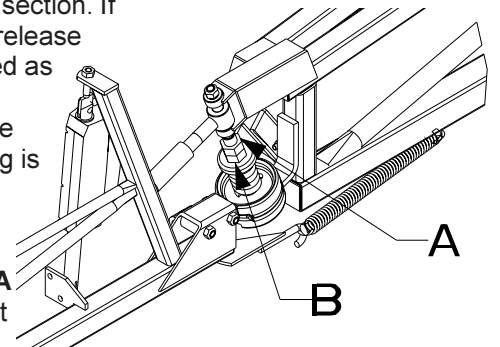

# Maintenance

## 500 hours service

### 1. Hydraulic oil filter

Change the hydraulic oil filter after the first 50 hours and then every 500 hours or once a year - whichever comes first.

Always change the oil filter if the vacuummeter indicator is in the red area. Check when the oil has reached working temperature.

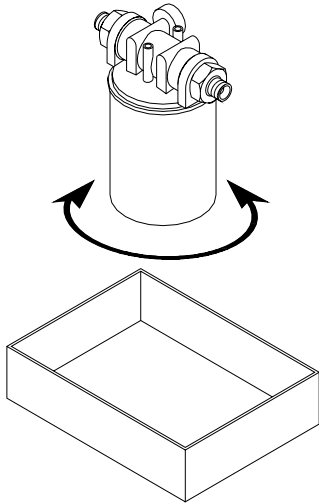

T192-0003

1. Place e.g. a drain pan or a cloth under the filter to retain waste oil and unscrew the filter cartridge.
2. The new filter cartridge is filled with fresh clean hydraulic oil. Apply a thin oil film to the cartridge seal.
3. Screw the filter cartridge on until the seal is lying against the flange.
4. Tighten the filter cartridge another 1/2 to 3/4 turn.
5. Check hydraulic oil level - top up with fresh clean hydraulic oil if necessary.
6. Set the blower in neutral, start the tractor P.T.O. and let it run idle for 5 min. to prime the system.
7. After 5 min. the blower r.p.m. can gradually be increased to full speed.

Disposal of used hydraulic filter cartridges must only take place in accordance with local legislation.



# Maintenance

## 1000 hours service

### 1. Wheel bearings and brakes

Check the condition of the bearings and brake wear parts in the following way:

1. Place stop wedges in front of and behind LH wheel and jack up RH wheel.
2. Support the trailer with axle stands.
3. Remove the wheel.
4. Remove the hub cap **A**, cotter pin **B** and castle nut **C**.
5. Pull off the wheel hub and brake drum assembly. Use a wheel puller if necessary.
6. Vacuum clean the brake drum **D** for brake dust or rinse with water.

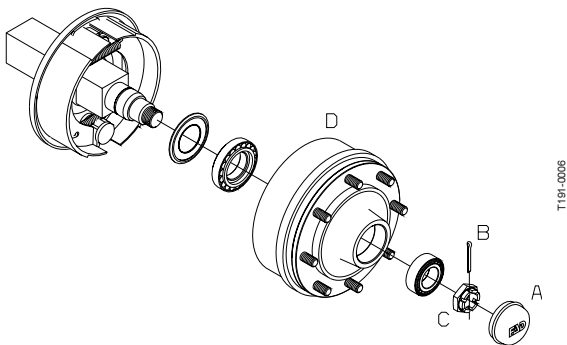

**WARNING!** Brake dust can cause severe health injuries! Avoid inhalation of brake dust! Use respirator when servicing the brakes. Do not clean brakes with compressed air! Use vacuum cleaner or rinse with water to avoid brake dust being blown around.

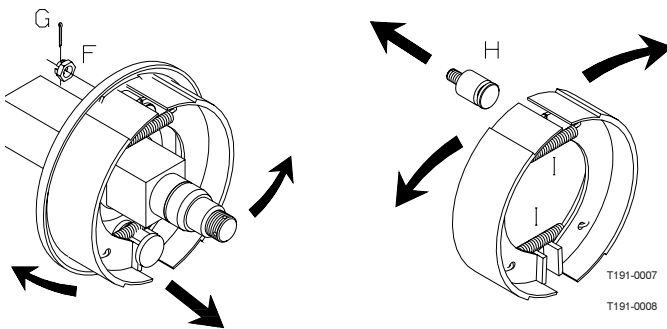

7. Rinse the remaining parts on the brake carrier plate with water and dry them.
8. Remove roller bearings **E**, clean all parts in degreasing detergent and dry them.
9. Check the brake drum diameter and lining thickness - renew if worn.

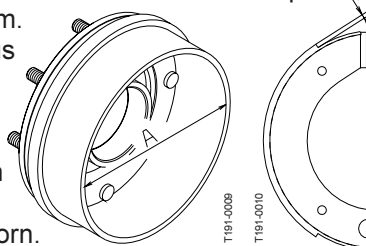

Max. wear rates on brake components, mm (in)		
Model	2200/2800	3200/4200
Max. drum diameter	A 302 (11.8897)	402 (15.8388)
Min. lining thickness	B 2.0 (0.07874)	4.0 (0.15748)

**IMPORTANT!** The specified min. thickness is the absolute minimum which must never be exceeded. Renew the parts if they would reach the above dimensions before next service inspection.

**IMPORTANT!** Renewal of brake linings or brake drums must be done both sides at the same time.

**NOTE!** If the brake drum must be removed from the hub, a hydraulic press is required to press the wheel studs out.

10. Remove the clevis pin between the air diaphragm cylinder and brake cam lever.
11. Remove the cotterpin **G** and nut **F**, the brake shoe anchor bolt **H** and slide the brake shoes over the cam. Twist the pair of brake shoes to remove the shoe return springs **I**. Replace brake shoes if the linings are worn.
12. Apply a small qty. of copper paste on moving parts and assemble the brake shoes and shoe return springs again.

**WARNING!** Do not get oil, grease or copper paste in contact with the brake linings and drums.

13. Fit the shoe assembly with the anchor bolt first. Then pull the shoes away from each other and slide them over the cam afterwards. Tighten the anchor bolt castellated nut again and fit a new cotter pin.
14. Check roller bearings for discoloration and wear - renew if worn or damaged.
15. Assemble the hub and bearings using a new sealing ring **J**.
16. Fill the hub and bearings with fresh grease before fitting it to the shaft.
17. Fit the castellated nut. Rotate the hub and tighten the castellated nut until a slight rotation resistance is felt.
18. Loosen the castellated nut again until the first notch is aligned with the cotter pin hole in the shaft.

**NOTE!** The shaft has a vertical and an horizontal cotter pin hole. Use the one first aligned with the notch when loosening the castellated nut.

19. Fit a new cotter pin and bend it.
20. Fill the hub cap with fresh grease and carefully press it on to the hub.
21. Adjust the brakes as described in "200 hours service".
22. Fit the wheel again and tighten the wheel nuts. See section "50 hours service" regarding torque wrench setting. Tighten all bolts to half the specified torque first, then to the full specified torque.
23. Tighten again after 10 hours of work. Check the torque every day until it is stabilised.

**WARNING!** If you do not feel totally confident changing wheel bearings or brake shoes contact your HARDI dealers workshop.

# Maintenance

## 2. Transmission shaft

Change the protection tube nylon bearings as described under "Replacement of transmission shaft protection tubes" in the part *Occasional Maintenance*.

## 3. Hydraulic oil change

The hydraulic oil is changed every 1000 hours or once a year - whichever comes first. The hydraulic oil change is best done when the fan has been working for at least one hour and the oil has reached working temperature.

Firstly, the used oil must be drained from the tank; this is done by the tap **A**.

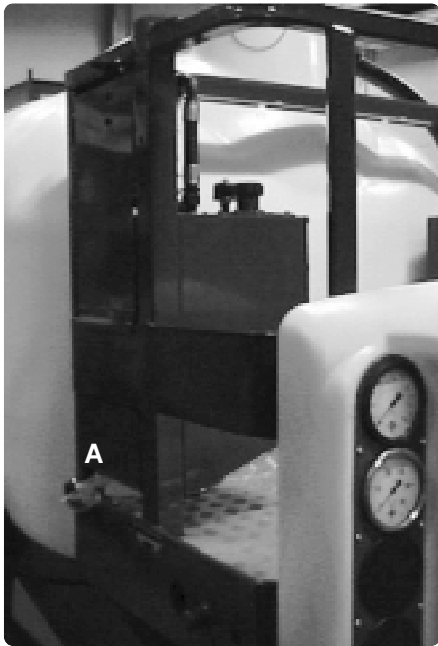

T067-0008

1. Remove the cap from the tap **A** and fit a hose connection + tube ( $\frac{1}{2}$ " ) to the tap **A**.
2. Open the ball-valve on the tap and lead the waste oil, via the tube, into an appropriate container.
3. Close the ball-valve and fit and tighten the cap to the tap **A** again when all the waste oil has been drained.

Additionally, new oil is filled into the tank.

1. Clean the area around the oil filling cap **B**.
2. Unscrew the filling cap and fill the tank with fresh, **clean** hydraulic oil until the level is between min. and max. on the level glass. The tank contains approx. 45 l. Regarding oil specification - see section on "Lubricants"
3. Fit the filling cap again.

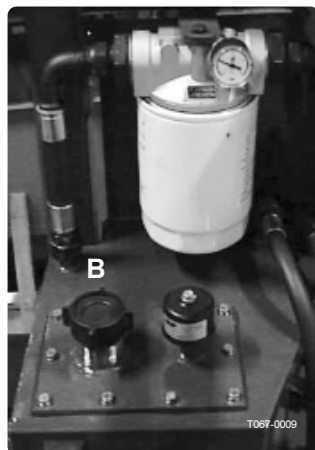

T067-0009

Note local legislation regarding disposal of waste oil.

## 4. Gear box oil change

The first gear box oil change must be done after 50 hours, then every 1000 hours or once a year - whichever comes first. The gear box oil change is best done when the machine has been working for at least one hour and the oil has reached working temperature.

1. Clean the area around filling plug/breather **A**, dip stick **B** and drain plug **C** thoroughly.
2. Place a tray under the drain plug to retain the waste oil.
3. Unscrew the filling and drain plugs and drain the gear box oil.
4. Refit the drain plug using a new seal - retighten.
5. Fill with fresh, clean oil until the level reaches the sight glass.  
Approx. oil quantity: 1.0 l (35.2 fl.oz.)  
Regarding oil quality, see section on "Lubricants"
6. Refit the dip stick and filling plug - retighten.

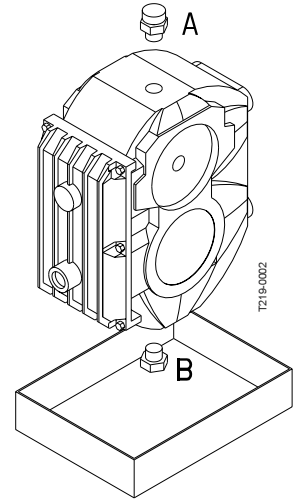

Disposal of waste oil must only be carried out in accordance with local legislation.

## 5. Hydraulic tank air filter

Change the hydraulic tank breathing filter.

1. Clean the area around the air filter thoroughly.
2. Remove screw **A**, washer **B** and cap **C**.
3. Renew the filter cartridge **D**.
4. Reassemble in reverse order.

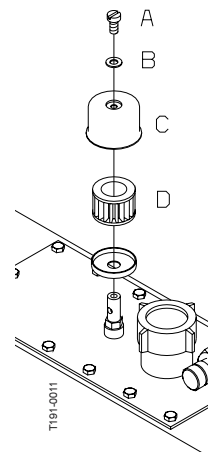

# Maintenance

## Occasional maintenance

The maintenance and renewal intervals for the following will depend very much on the conditions under which the sprayer will be operated and are therefore impossible to specify.

### Pump valves and diaphragms renewal

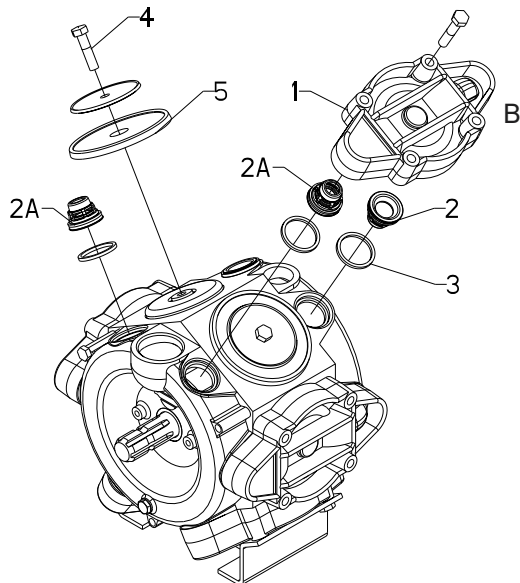

T261-0001

Diaphragm pump overhaul kit (valves, seals, diaphragms etc.)

Pump model	HARDI part No.
363	750342
463	750343

#### Valves

Remove valve cover **1** before changing the valves **2** - note their orientation so they are replaced correctly!

**NOTE:** One special valve with white flap **2A** is used. It has to be placed in the valve opening shown.

It is recommended to use new gaskets **3** when changing or checking the valves.

#### Diaphragms

Remove the diaphragm cover **4**. The diaphragm **5** may then be changed. If fluids have reached the crankcase, re-grease the pump thoroughly. Also check that the drain hole at the bottom of the pump is not blocked. Reassemble with the following torque setting.

Pump model	Diaphragm cover Nm	Diaphragm bolt Nm
463	90	90
463	90	90

1 Nm = 0.74 lbf

**IMPORTANT!** Before tightening the 4 bolts for the diaphragm cover **B** the diaphragm must be positioned between centre and top to ensure correct sealing between diaphragm pumphousing and diaphragm cover. Turn crank shaft if necessary.

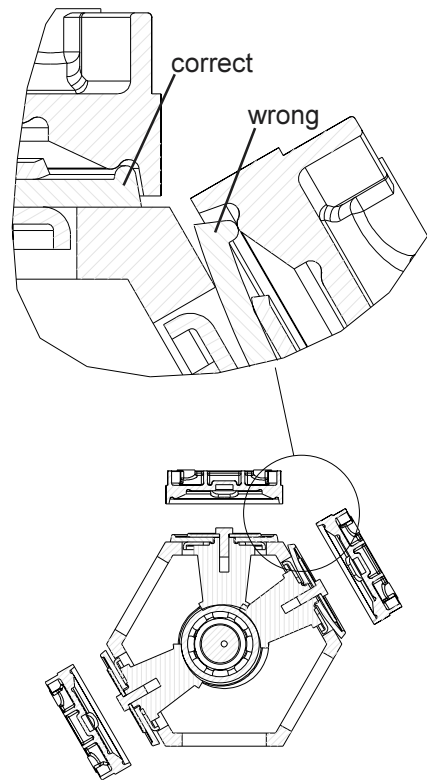

T192-0005x

### Cone check/renewal EVC operating unit

If it becomes difficult to build up sufficient pressure or if pressure fluctuations occur, it may be necessary to renew cone and cylinder. A HARDI kit is available for this purpose. Ref. no. 741293.

1. Remove 4 x screws **A** and remove the housing.
2. Remove 4 x screws **B**.

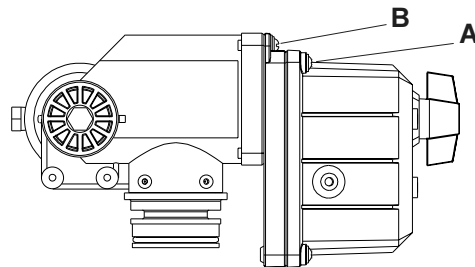

T192-0007x

3. Replace cylinder **C** and O-ring **D**.
4. Loosen the nut **E**, remove and replace the cone **F**.
5. Reassemble in reverse order.

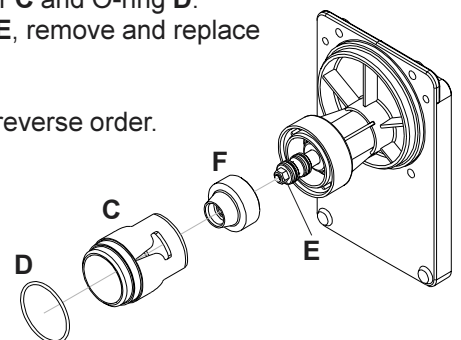

# Maintenance

## Cone check/renewal, EVC distribution valve

Periodically check the distribution valves for proper sealing. Do this by running the sprayer with clean water and open all distribution valves.

Cautiously remove the clip **A** and pull out the hose **B** for the pressure equalisation device. When the housing is drained, there should be no liquid flow through the pressure equalisation device. If there is any leakage, the valve cone **E** must be changed.

Remove the clip **C** and lift the motor housing off the valve housing. Then unscrew the screw **D** and replace the valve cone **E**. Reassemble in reverse order.

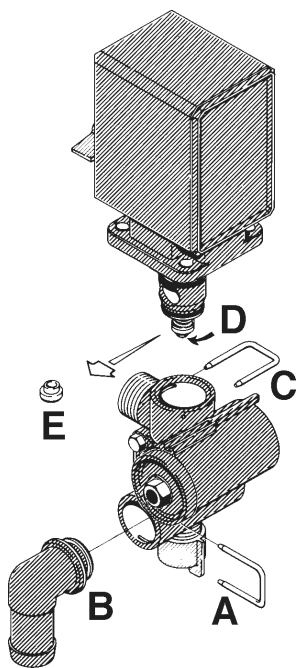

## Wear bush renewal, boom lift

The wear bushes are inspected and renewed before they are worn through.

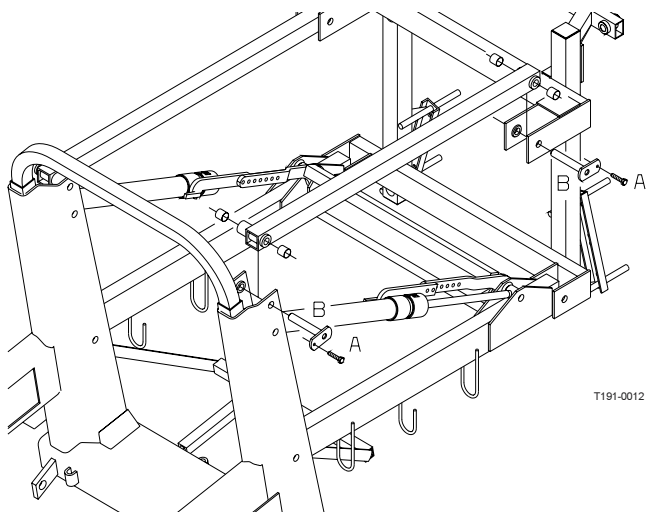

1. Connect the trailer to a tractor and unfold the booms to working position.
2. Lift the boom centre frame with a lifting device and support it until the load is taken off the parallelogram arms.
3. Remove the screws **A**, and pull out the pins **B** at one of the upper parallelogram arms and renew the wear bushes.
4. Refit the arm.
5. Repeat this on the other upper arm.

6. The lower arms must be disconnected simultaneously.

Grease all grease nipples.

7. Remove the lifting gear again.

## Wear bush renewal, drawbar (all TRACKER models)

If too much play is found in the drawbar the wear bushes must be renewed.

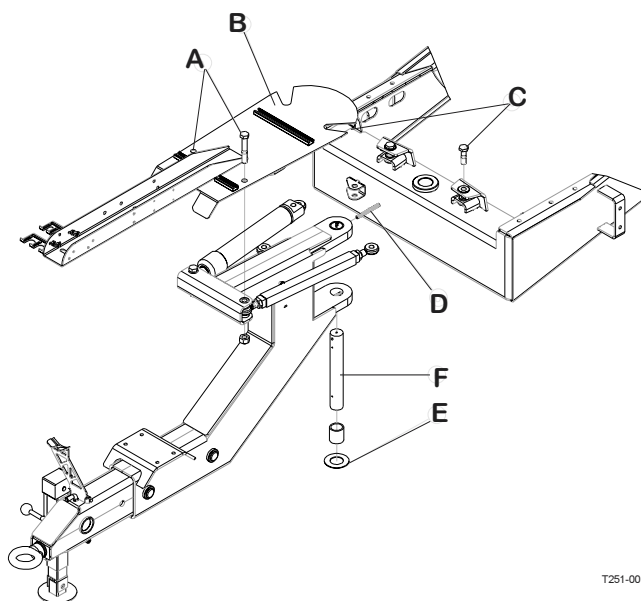

T251-0017

1. Place stop wedges in front of and behind both wheels.
2. Jack up the frame and support it properly.
3. If *not* a SELF TRACK model: Remove the drawbar extension to reduce the weight of the drawbar.
4. Loosen the two bolts **A** and support the bracket **B** in order to keep it in a level position (e.g. by a rope fastened to the platform railing).
5. Without dismantling the hydraulic system the hydraulic rams are removed from the drawbar by loosening the nuts **C**.
6. Support the drawbar and remove the two pin bolts **D**, the washer **E** and the pin **F**.
7. Move the drawbar to the side and support it.
8. Press out the worn bushes and fit new ones.
9. Assemble again in reverse order.
10. Grease through grease nipples and remove jack and wedges.
11. Fit the extension piece in the drawbar again and place the sprayer on the support leg



# Maintenance

## Venting the hydraulic damping system (SELF TRACK only)

The following venting procedure requires a special venting kit, HARDI ref. no. 720725.

1. Place the trailer on the support leg so that the yoke goes free from the tractor and the rams can work freely.
2. Relieve the pressure in the expansion tank and remove the hydraulic hose.

NOTE! Plug the hose. If this is neglected, the pressure gauge may be damaged.

3. Fit the two test hoses in the pressure gauge outlets on the rams (at the rear of the track system).
4. Move the track system from one side to the other approx. 10 times (full swing).
5. Loosen the plug very carefully in order to leak the air out of the system.
6. Fit the hydraulic hose on the expansion tank.
7. Remove the level plug and using the tractor hydraulics, cautiously fill oil in the expansion tank until it reaches the level plug.
8. Fit the level plug and fill the expansion tank to an air pressure of 5 bar.
9. Fit the 0-400 bar pressure gauge on the pressure gauge outlet at the ram. Adjust the excess-pressure valve to approx. 40 bar.

On flat ground it is possible to work with a lower opening pressure. This gives a more sensible reaction but it also results in the fact that the trailer can swing when driving on hilly ground and when swinging at high speed.

## TRACKER damping pressure setting (SELF TRACK only)

The hydraulic pressure relief valves in the TRACKER's damping system is factory set to open at approx. 40 bar (580 p.s.i.) which is adequate for most conditions.

If the damping seems too "soft" or too "hard", the settings can be adjusted on the screws shown.

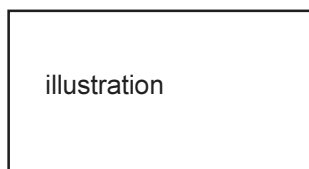

## Shock absorbers

If the shock absorbers loose their efficiency or start leaking oil, they should be replaced.

## Level indicator adjustment

The level indicator reading should be checked regularly.

When the tank is empty, the float should lie on the stop pin, of the rod, and the O-ring on the indicator should be positioned at the top position line **A**.

If any deviation is found, pull out the plug **B**, loosen screws **C**, and adjust the length of the cord.

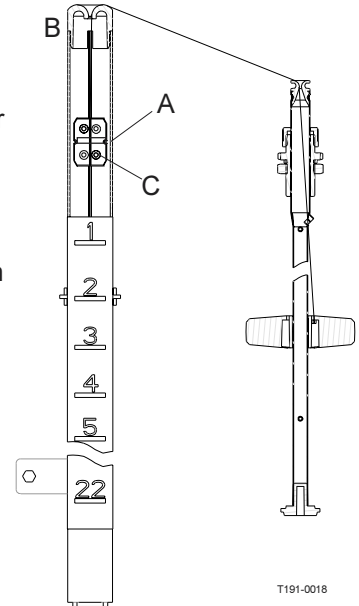

## Cord renewal, level indicator

If the cord on the level indicator has to be changed, the float guide pole is removed:

1. Remove the tank drain valve (see paragraph "Main tank drain valve") and loosen the fitting holding the pole in position.
2. Pull the pole down through the drain valve hole till it is free in the top of the tank.
3. The pole can now be taken out of the tank through the filling hole.



**DANGER!** Do not attempt to enter the tank - the float pole can be removed from outside the tank!

## Seal renewal, drain valve

If the main tank drain valve leaks, the seal and seat can be changed the following way.



**DANGER!** Do not enter the inside of the tank - the parts can be changed from underneath the tank!



**WARNING!** Use eye / face protection mask when dismantling the tank drain valve!

1. Make sure the tank is empty and clean.
2. The valve must be closed and the string loose.

# Maintenance

- Pull out the clip **A** and pull down connecting piece **B**. The entire valve assembly can now be pulled out.
- Check cord and valve flap assembly **C** for wear, replace seal **D** and assemble again.
- Assemble the valve assembly again using a new valve seat **E**. Lubricate O-rings **F** before assembly.
- Fit clip **A** again.

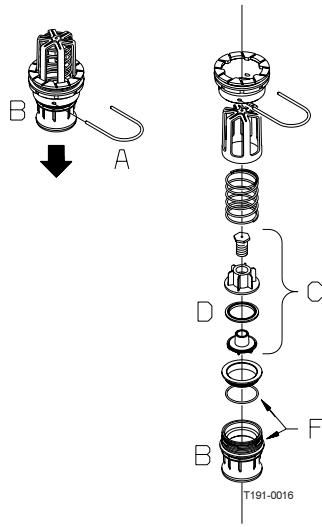

NOTE! Check function of valve with clean water before filling chemicals into the tank.

## Nozzle tubes and fittings

Poor seals are usually caused by:

- missing O-rings or gaskets
- damaged or incorrectly seated O-rings
- dry or deformed O-rings or gaskets
- foreign bodies

In case of leaks:

**DO NOT overtighten.** Disassemble, check condition and position of O-ring or gasket. Clean, lubricate and reassemble.

The O-ring must be lubricated **ALL THE WAY ROUND** before fitting on to the nozzle tube. Use non-mineral lubricant.

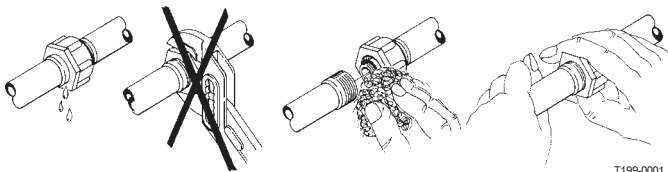
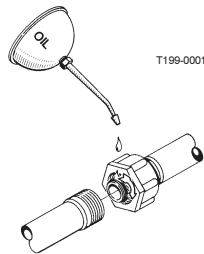

For **RADIAL** connections only hand-tighten them.

For **AXIAL** connections, a little mechanical leverage may be used.

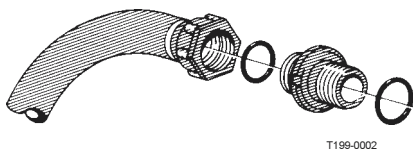

## Adjustment of 3-way-valve

The MANIFOLD valve can be adjusted if it is too tight to operate - or if it is too loose (= liquid leakage).

Use a suitable tool and adjust the toothed ring inside the valve as shown on the drawing.

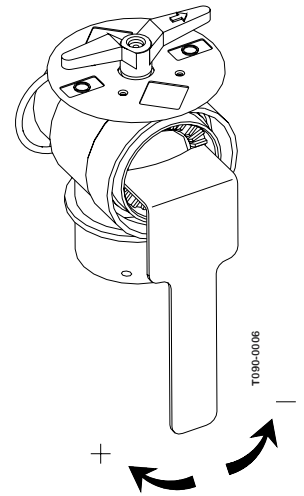

## Change of bulbs

Overview of bulbs used.

Rear combi lamp, HELLA		
Function	Bulb type (DIN)	Volt / Watt
Rear lamp	R5W	12V / 5W
Stop lamp	P21W	12V / 21W
Direction indicator	P21W	12V / 21W
Rear combi lamp, GEKA (with warning boards)		
Function	Bulb type (DIN)	Volt / Watt
Rear lamp	R5W	12V / 5W
Stop lamp	P21W	12V / 21W
Direction indicator	P21W	12V / 21W
Position lamp, front	(GEKA)	12V / 5W
Boom and work lamps		
Function	Bulb type (DIN)	Volt / Watt
Boom lamp	H3	12V / 55W
Working lamp	124 98	12V / 21W
Number plate lamp, HELLA		
Function	Bulb type (DIN)	Volt / Watt
Number plate lamp	R10W	12V / 10W
Side marking combi lamp		
Prise out the lens carefully from the rubber housing to remove the bulb.		
Function	Bulb type (DIN)	Volt / Watt
Side marking combi lamp white, red yellow	R5W	12V / 5W



# Maintenance

## To change a bulb

1. Switch off the light
2. Loosen the screws on the lamp and remove the cover or lens.
3. Remove the bulb
4. Fit a new bulb, refit the cover and tighten the screws.

**NOTE!** If halogen bulbs are used, never touch the bulb with the fingers. Natural moisture in the skin will cause the bulb to burn out when the light is switched on. Always use a clean cloth or tissue when handling halogen bulbs.

## Adjustment of slanting indicator

If the position of the pointer on the indicator does not correspond to the actual boom position, the pointer **A** can be adjusted.

1. Loosen the small bolt **B** sufficiently to allow the wire **C** to be adjusted.
2. Place the pointer **A** in correct position and fasten bolt **B** against the wire **C** again.

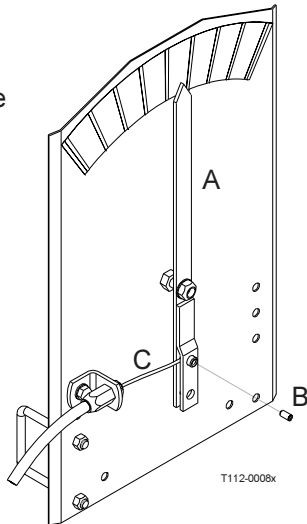

3. Grease protection tube bearing groove on the inner yoke.

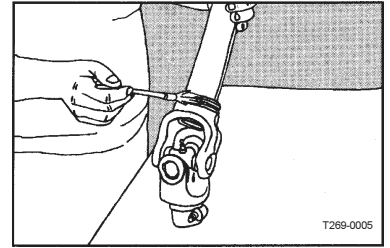

4. Slide on the shield tube and fit the bearings tabs into the slots.

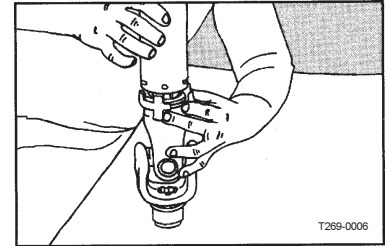

5. Slide the universal cross cover over the protection tube and align the grease nipple with the grease channel on the bearing. Press the universal cross cover onto the tabs until they lock.

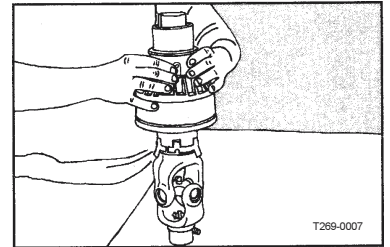

6. Check alignment and locking of the tabs by tapping the universal cross cover lightly.

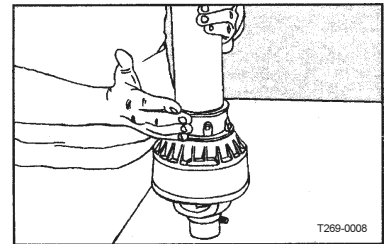

## Transmission shaft, shield renewal

The replacement of defective shields is done as follows:

1. Push down on the universal cross cover and press in the tabs with a screwdriver. Maintain pressure until all three tabs are released.

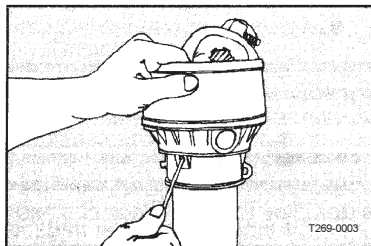

2. Remove the nylon bearing and pull off the protection tube.

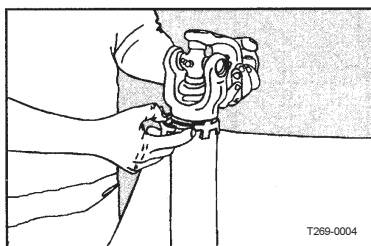

## Constant Velocity joint shielding

1. Remove the screws holding the two halves of the shield together.

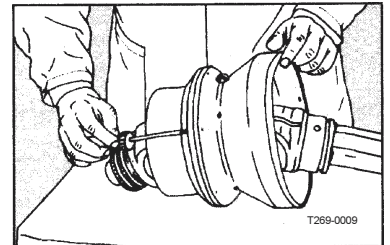

2. Separate the shield and remove it from the joint. Check and replace any worn or damaged parts.

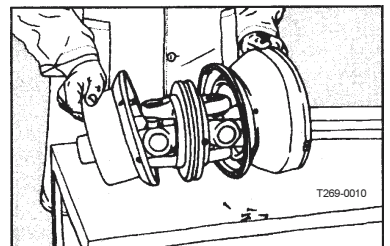

# Maintenance

3. Lubricate the bearing surfaces on the central body of the joint. Align the two halves of the shield and secure with screws.

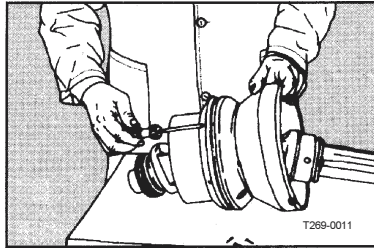

**NOTE!** Use only genuine spare parts to service the transmission shaft. For any other service or repair jobs on the transmission shaft contact your HARDI dealer.

## Change of tyre

Should it be necessary to replace tyres, it is recommended to leave this to a specialist and follow the mentioned rules.

1. Always clean and inspect the rim before mounting.
2. Always check that the rim diameter corresponds exactly to the rim diameter moulded on the tyre.
3. Always inspect inside of the tyre for cuts, penetrating objects or other damages. Repairable damages should be repaired before installing the tube. Tyres with unrepairable damages must never be used.
4. Also inspect inside of the tyre for dirt or foreign bodies and remove it before installing the tube.
5. Always use tubes of recommended size and in good condition. When fitting new tyres always fit new tubes.
6. Before mounting, always lubricate both tyre beads and rim flange with approved lubricating agent or equivalent anti-corrosion lubricant. Never use petroleum based greases and oils because they may damage the tyre. Using the appropriate lubricant the tyre will never slip on the rim.
7. Always use specialised tools as recommended by the tyre supplier for mounting the tyres.
8. Make sure that the tyre is centred and the beads are perfectly seated on the rim. Otherwise danger of bead wire tear can occur.
9. Inflate the tyre to 100-130 kPa (14.5-19 p.s.i.) then check weather both beds are seated perfectly on the rim. If any of the beads do not seat correctly, deflate the assembly and re-centre the beads before starting inflation of the tyre. If the beads are seated correctly on the rim at 100-130 kPa inflate the tyre to a maximum of 250 kPa (36 p.s.i.) until they seat perfectly on the rim.
10. Never exceed the maximum mounting pressure moulded on the tyre!
11. After mounting tyres adjust inflation pressure to operation pressure recommended by the tyre manufacturer.
12. Do not use tubes in tubeless tyres.



**WARNING!** Non observance of mounting instructions will result in the bad seating of the tyre on the rim and could cause the tyre to burst leading to serious injury or death!

Never mount or use damaged tyres or rims!

Use of damaged, ruptured, distorted, welded or brazed rim is not allowed!

# Maintenance

## Fan speed adjustment

(Bowden cable adjusted pumps only). The boom fan speed base adjustments are carried out as follows.

A tachometer is required for this job.

1. Fit a piece of light-reflecting tape to the fan wing and to the tractor P.T.O.
2. Unfold the boom to working position.
3. Set tractor P.T.O. at 540/1000 r.p.m. - check with the tachometer.
4. Set the fan speed control lever to max. speed.
5. Measure the fan speed with the tachometer. The fan speed must be 3100 r.p.m.



**WARNING!** Do not wear loose hanging clothes! Hold the tachometer firmly in your hands in order not to be sucked into the fan. **DO NOT REMOVE THE PROTECTION GRID!**

6. Turn the swash plate adjustment screw **E** CW to decrease or CCW to increase the blower r.p.m. Remember to tighten the counter nut. Repeat 3. and 4. until the correct setting is obtained.

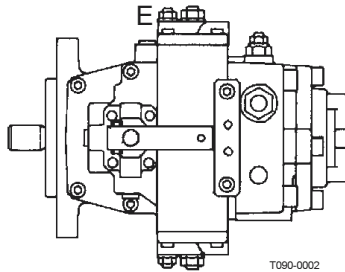

7. If the correct fan r.p.m. cannot be reached, the hydraulic transmission pressure settings must be checked - see section on "Fan transmission pressure adjustment".

## Fan transmission priming

If the hydraulic fan transmission has been dismantled, or pump or motor has been changed, the following priming procedure must be carried out before starting up the transmission:

1. Fill the oil reservoir with fresh, clean oil to the top of the sight glass.
2. Fill the pump housing with oil through the drain pipe **D** which is dismantled at the tank connection. Reconnect and tighten.
3. Check the oil level in the gear box.
4. Remove the drain hose **D** from the motor outside the blower housing.
5. Set the fan r.p.m. at 0, engage the tractor P.T.O. with the engine running idling - wait a few minutes.
6. Set the fan speed at 200 r.p.m.
7. After a while the oil will start dripping constantly. Refit

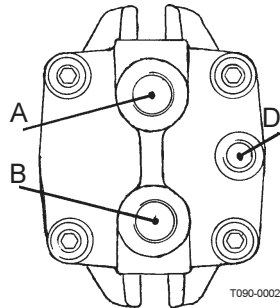

the drain hose and tighten.

8. With the tractor P.T.O. at 540/1000 r.p.m. the fan should rotate at max. revolutions/min.
9. Recheck oil level at tank sight glass.
10. Check vacuummeter at the suction filter.
11. Retighten hose connections and check for leaks.
12. Check fan speed and feed pressure adjustments - see sections on "Fan speed adjustment" and "Fan transmission pressure adjustment".

## Fan transmission pressure adjustment

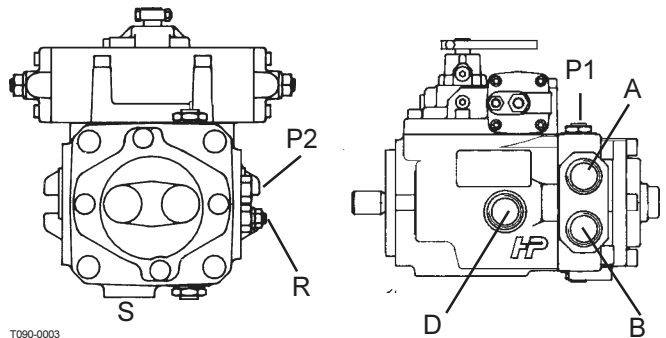

- A = Pressure port
- B = Return port
- D = Drain port
- P1 = Connector for working pressure measurement
- P2 = Connector for feed pressure
- R = Adjustment Screw for feed pressure
- S = Suction port

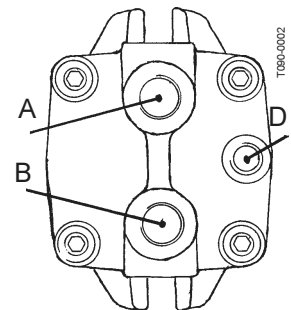

The transmission feed and working pressure are checked as follows:

1. Connect a 40 bar (580 p.s.i.) pressure gauge to the feed pressure connector **P2**, and a 400 bar (5800 p.s.i.) pressure gauge at the working pressure connector **P1**.
2. Set the tractor P.T.O. at 540/1000 r.p.m. - check with tachometer.
3. Set the blower at max. speed.
4. Check the feed and working pressure:

# Maintenance

---

**Feed pressure, P2 15-20 bar (218-290 p.s.i.)**  
**Working pressure, P1, approx.**

15 m	160 bar (2321 p.s.i.)
16 m	170 bar (2466 p.s.i.)
18 m	180 bar (2610 p.s.i.)
20 m	190 bar (2755 p.s.i.)
21 m	200 bar (2900 p.s.i.)
24 m	240 bar (3721 p.s.i.)
27 m	240 bar (3721 p.s.i.)
28 m	240 bar (3721 p.s.i.)

Adjust feed pressure if necessary.

Failure to reach feed and working pressure indicates that the transmission needs overhauling.

# Maintenance

## Off-season storage

When the spraying season is over, you should devote some extra time to the sprayer.

If chemical residue is left over in the sprayer for longer periods, it can reduce the life of the individual components.

## Off-season storage program

To preserve the sprayer intact and to protect the components, carry out following off-season storage program.

1. Clean the sprayer completely - inside and outside - as described under "Cleaning of the sprayer". Make sure that all valves, hoses and auxiliary equipment have been cleaned with detergent and flushed with clean water afterwards, so no chemical residue is left in the sprayer.
2. Renew possible damaged seals and repair possible leaks.
3. Empty the sprayer completely and let the pump work for a few minutes. Operate all valves and handles to drain as much water off the spraying circuit as possible. Let the pump run until air is coming out of all nozzles. Remember to drain the rinsing tank also.
4. Pour appr. 50 litre anti-freeze mixture consisting of 1/3 automotive anti-freeze and 2/3 water into the tank.
5. Engage the pump and operate all valves and functions on the MANIFOLD, operating unit, FILLER etc. allowing the anti-freeze mixture to be distributed around the entire circuit. Open the operating unit main on/off valve and distribution valves so the anti-freeze is sprayed through the nozzles as well. The anti-freeze will also prevent O-rings, seals, diaphragms etc. from drying out.
6. Lubricate all lubricating points according to the lubricating scheme - regardless of intervals stated.
7. When the sprayer is dry, remove rust from possible scratches or damages in the paint and touch up the paint.
8. Remove the glycerine-filled pressure gauges and store them frost free in vertical position.
9. Apply a thin layer of anti-corrosion oil (e.g. SHELL ENSIS FLUID, CASTROL RUSTILLO or similar) on all metal parts. Avoid oil on rubber parts, hoses and tyres.
10. Fold the boom in transport position and relieve pressure from all hydraulic functions.

11. All electric plugs and sockets are to be stored in a dry plastic bag to protect them against damp, dirt and corrosion.
12. Remove the control boxes and the HARDI PILOT or HARDI NOVA control box + display from the tractor, and store them dry and clean (in-house).
13. Wipe hydraulic snap-couplers clean and fit the dust caps.
14. Apply grease on all hydraulic ram piston rods which are not fully retracted in the barrel to protect against corrosion.
15. Chock up the wheels, to prevent moisture damage and deformation of the tyres. Tyre blacking can be applied to the tyre walls to preserve the rubber.
16. Drain air brake tank for condensed water.
17. Change hydraulic oil and hydraulic filter as described in section on "Maintenance".
18. To protect against dust the sprayer can be covered by a tarpaulin. Ensure ventilation to prevent condensation.

## Preparing the sprayer for use after storage

After a storage period the sprayer should be prepared for the next season the following way:

1. Remove the cover
2. Remove the support from the wheel axle and adjust the tyre pressure.
3. Wipe off the grease from hydraulic ram piston rods.
4. Fit the pressure gauges again. Seal with Teflon tape.
5. Connect the sprayer to the tractor including hydraulics and electric's.
6. Check all hydraulic and electric functions.
7. Empty the tank for remaining anti-freeze.
8. Rinse the entire liquid circuit on the sprayer with clean water.
9. Fill with clean water and check all functions.
10. Check function of brakes. Please note that brake power will be reduced until the rust are worn off the drums. Always brake lightly until the drums are clean.

# Fault-finding

## Fault-finding

### Operational problems

In cases where breakdowns have occurred, the same factors always seem to be the problem:

1. Minor leaks on the suction side of the pump will reduce the pump capacity or stop the suction completely.
2. A clogged suction filter will hinder or prevent suction so that the pump does not operate satisfactorily.
3. Clogged up pressure filters will result in increasing pressure at the pressure gauge but lower pressure at the nozzles.
4. Foreign bodies stuck in the pump valves with the result that these cannot close tightly against the valve seat. This reduces pump efficiency.
5. Poorly reassembled pumps, especially diaphragm covers, will allow the pump to suck air resulting in reduced or no capacity.
6. Hydraulic components that are contaminated with dirt result in rapid wear to the hydraulic system.

Therefore ALWAYS check:

1. Suction, pressure and nozzle filters are clean.
2. Hoses for leaks and cracks, paying particular attention to suction hoses.
3. Gaskets and O-rings are present and in good condition.
4. Pressure gauge is in good working order. Correct dosage depends on it.
5. Operating unit functions properly. Use clean water to check.
6. Hydraulic components are maintained clean.

### TRACKER damping system

FAULT	PROBABLE CAUSE	CONTROL/REMEDY
Sprayer trails unstable	Air pockets in the hydraulic circuit	Prime hydraulic circuit
	Hydraulic circuit leaking	Repair leak, prime
	Pressure relief valve(s) set too low	Adjust pressure relief valves
Front hydraulic rams will not allow the yoke to turn when rear rams are extended/retracted to the maximum	Safety valve incorrectly adjusted	Adjust safety valve
Rear hydraulic rams are too tight and vehicle continues straight ahead when trying to turn	Insufficient counter weight on front of tractor	Ad ballast on front of tractor
	Pressure relief valve set too high	Adjust pressure relief valves



# Fault-finding

## Liquid system

FAULT	PROBABLE CAUSE	CONTROL/REMEDY
No spray from boom when turned on.	Air leak on suction line.	Check if suction filter O-ring is sealing. Check suction tube and fittings. Check tightness of pump diaphragm and valve covers.
	Air in system.	Fill suction hose with water for initial prime.
	Suction/pressure filters clogged.	Clean filters. Check yellow suction pipe is not obstructed or placed too near the tank bottom.
Lack of pressure.	Incorrect assembly.	Restrictor nozzle in Self-Cleaning Filter not fitted. Safety valve spring for Self-Cleaning Filter not tight. Too little distance between yellow suction pipe and tank bottom.
		Pump valves blocked or worn.
	Defect pressure gauge.	Check for dirt at inlet of gauge.
Pressure dropping.	Filters clogging.	Clean all filters. Fill with cleaner water. If using powders, make sure agitation is on.
	Nozzles worn.	Check flow rate and replace nozzles if it exceeds 10%.
	Tank is air tight.	Check vent is clear.
	Sucking air towards end of tank load.	Lower pump r.p.m.
Pressure increasing	Pressure filters beginning to clog.	Clean all filters.
Formation of foam.	Air is being sucked into system.	Check tightness / gaskets / O-rings of all fittings on suction side.
	Excessive liquid agitation.	Reduce pump r/min. Check safety valve for Self-Cleaning Filter is tight. Ensure returns inside tank are present. Use foam damping additive.
Liquid leaks from bottom of pump.	Damaged diaphragm.	Replace. See Changing of valves and diaphragms.

# Fault-finding

## EVC Operating unit

FAULT	PROBABLE CAUSE	CONTROL/REMEDY
Operating unit not functioning	Blown fuse(s).	Check mechanical function of micro-switches. Use cleaning/lubricating agent if the switch does not operate freely.  Check motor. 450-500 milli-Amperes max. Change motor, if over.
	Wrong polarity.	Brown - pos. (+). Blue - neg. (-).
	Valves not closing properly.	Check valve seals for obstructions.  Check micro-switch plate position. Loosen screws holding plate a 1/2 turn.
	No power.	Wrong polarity. Check that brown is pos. (+), Blue is neg. (-).  Check print plate for dry solders or loose connections.  Check fuse holder are tight around fuse.

## Hydraulic system (Tractor Operated Hydraulics)

FAULT	PROBABLE CAUSE	CONTROL/REMEDY
Boom slow/eradic.	Air in system	Loosen ram connection and activate hydraulics until oil flow has no air in it (not whitish).
	Regulation valve incorrectly set	Open or close until desired speed is achieved (clockwise = less speed).  Remember oil must be at operating temperature.
	Insufficient hydraulic pressure	Check output pressure of tractor hydraulics. Minimum for sprayer is 130 bar.
	Insufficient amount of oil in tractor reservoir	Check and top up if needed.
Ram not functioning.	Restrictor or regulation valve blocked	Secure boom with "S" hook. Dismantle and clean.

# Fault-finding

## Hydraulic system (Direct Acting Hydraulic System)

FAULT	PROBABLE CAUSE	CONTROL/REMEDY
No boom movements when activated	Insufficient oil pressure	Check oil pressure - min. 130 bar, max. 160 bar.  Check tractor hydraulic oil level
	Insufficient oil supply.	Oil flow must be min. 10 l/min. and max. 90 l/min.  Check tractor hydraulic oil level.
	Blown fuse.	Check / replace fuse in junction box.
	Bad / corroded electrical connections	Check / clean connections, multi plugs etc.
	Insufficient power supply.	Voltage on activated solenoid valve must be more than 8 Volts. Use wires of at least 4 mm <sup>2</sup> for power supply.
	Defect relay / diodes in junction box.	Check relays, diodes and soldering at PCB in junction box
	Clogged restrictors <b>B</b> or <b>C</b> in by-pass block.	Remove and clean restrictors <b>B</b> and <b>C</b> in by-pass block (See hydraulic diagram) Change hydraulic oil + filter
	Wrong polarity.	Check polarity. White pos. (+) Blue neg. (-).
Boom lift raises to max. pos. when tractor hydraulics are engaged	Wrong oil inlet to by-pass block.	Connect hydraulic snap couplers opposite in tractor outlets, or engage spool valve lever in opposite direction
	Back pressure in return line exceeds 20 bar	Connect the return line with free flow to hydraulic oil reservoir.  Divide return line in two and lead return oil back to reservoir via two spool valves.
Oil heats up in Closed Centre systems	By-pass valve <b>0</b> does not close properly	Check / replace locking clip on by-pass valve <b>0</b> .
	Internal leaks in flow regulator	Replace flow regulator O-rings and back-up rings. Replace flow regulator.
Individual ram does not move	Clogged restrictor	Dismantle and clean restrictor

# Fault-finding

## Hydraulic fan transmission

FAULT	PROBABLE CAUSE	CONTROL/REMEDY
Max. revolutions cannot be obtained	Tractor P.T.O. speed is lower than 540 r.p.m. (reading failure on tractometer)	Check tractor's P.T.O. r.p.m. Check tractometer
	Feed pressure is too low	Adjust feed pressure to correct setting
	Max. fan r.p.m. is not adjusted correctly (models with bowden cable adjustment only)	Adjust the max. fan r.p.m.
	Pump/motor is worn	Get transmission checked by your HARDI dealer
Noisy fan transmission	Wrong oil quality (foam)	Change oil to correct quality
	Feed pressure too low	Adjust feed pressure
	Oil filter clogged (vacuummeter indicator in red area)	Change oil filter
Formation of foam in oil tank	Pump/motor is worn	Get the fan transmission checked by your HARDI dealer
	Wrong oil quality	Change the oil to correct quality
	Mixture of hydraulic oil and other quality (e.g. universal oil)	Change the oil to correct quality
	Oil change interval not kept	Change the oil to fresh, clean oil of correct quality
	Leak on the pump suction line	Check hydraulic pump suction line for leaks
Fan speed will not stay at adjusted level	No signal from speed sensor at the fan	Check the wire connection between sensor and actuator for damages
	Bad connections	Check the wire connection between sensor and actuator for damages
Fan r.p.m. control does not start up	Fuse blown	Check power supply and fuse
Oil leaks from pump/motor shaft seal (seal pressed out)	Drain hoses from motor/pump housing is blocked	Check the drain hose(s) for bendings, damages, and proper attachment
	Too much pressure in pump/motor housing (pump/motor worn)	Get the transmission checked by your HARDI dealer

# Fault-finding

## Emergency operation of the sprayer

### The boom

In case of power failure, the boom can be operated manually:

1. Put the tractor spool valve control lever in neutral position.
2. Close the cartridge valve **A** on the hydraulic distribution block.

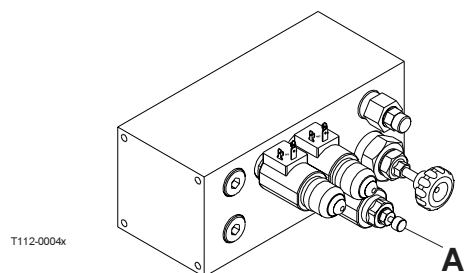

3. Activate the tractor spool valve control lever.
4. The boom can now be operated by pressing the individual buttons on the solenoid valves.

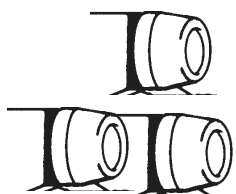

Remember to reset the system to original setting.

### Steering drawbar (if fitted)

1. Put the tractor spool valve control lever in neutral position.
2. Close the cartridge valves **A** and **B** on the hydraulic distribution block.
3. By means of the tractor spool valve control lever, the drawbar can now be centred.

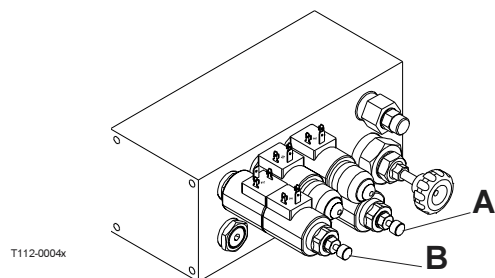

Remember to reset the system to original setting.

### Cause

The problem may be due to a blown fuse. One spare fuse is located inside the junction box.

## EC operating unit

In case of power failure it is possible to operate all functions of the operating unit manually. First disconnect the multi plug from the control box. Now manually turn the emergency control knobs.

The problem may be due to a blown fuse. An extra fuse is placed inside the box.

Fuse type: 6.3 A

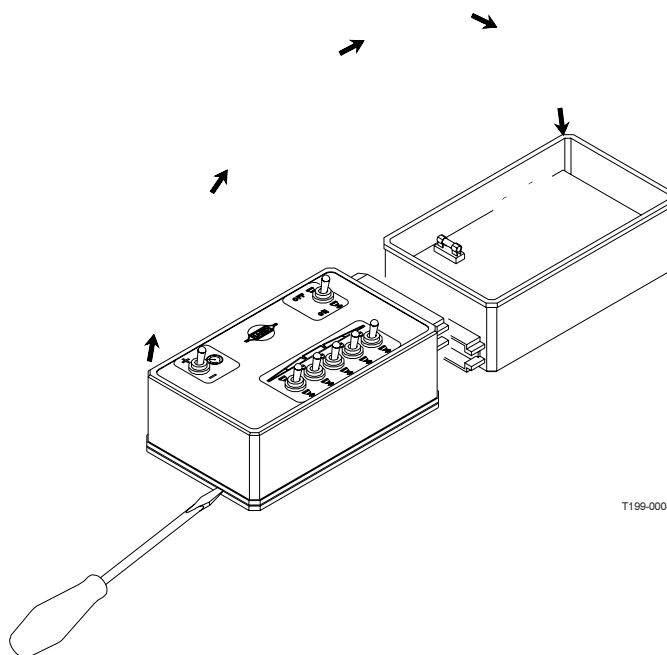

# Technical specifications

## Technical specifications

### Overall dimensions

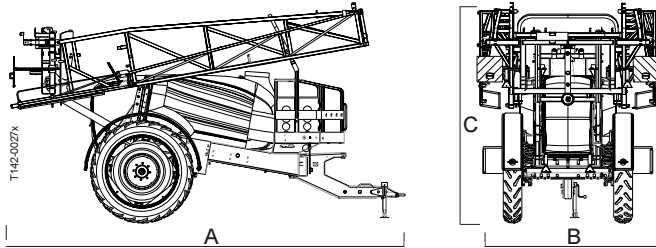

C0 plus 2200/2800 HAY/HAZ			
Boom width (m)	A (mm)	B (mm)	C (mm)
	High hitch/Low hitch		
18	6800/6800	2990	3860
20	6800/6800	2990	3860
21	6800/6800	2990	3860
24	6800/6800	2990	3860
27	6800/6800	2990	3860
28	6800/6800	2990	3860

C0 plus 3200/4200 HAY/HAZ			
Boom width (m)	A (mm)	B (mm)	C (mm)
	High hitch/Low hitch		
18	7100/6830	2990	3860
20	7100/6830	2990	3860
21	7100/6830	2990	3860
24	7100/6830	2990	3860
27	7100/6830	2990	3860
28	7100/6830	2990	3860

All measurements are in mm and are based on machines equipped with wheel size 12.4 x R46.

The length (A) is based on the short version of the drawbar extension. Additional length for long version:

CM 2200/2800: + 350 mm

CM 3200/4200: + 450 mm

### Weight

CM plus 2200 HAY/HAZ						
Boom width (m)	Empty			Full		
	Axle load (kg)	Drawbar load (kg)	Own weight (kg)	Axle load (kg)	Drawbar load (kg)	Total weight (kg)
18	3310	654	3964	5377	1209	6586
20	3320	659	3979	5387	1214	6601
21	3333	666	3999	5401	1220	6621
24	3360	679	4039	5427	1234	6661
27	3416	708	4124	5483	1263	6746
28	3425	714	4139	5492	1269	6761

CM plus 2800 HAY/HAZ						
Boom width (m)	Empty			Full		
	Axle load (kg)	Drawbar load (kg)	Own weight (kg)	Axle load (kg)	Drawbar load (kg)	Total weight (kg)
18	3329	660	3989	5754	1302	7056
20	3339	665	4004	5764	1307	7071
21	3353	671	4024	5777	1314	7091
24	3380	684	4064	5804	1327	7131
27	3435	714	4149	5860	1356	7216
28	3444	720	4164	5869	1362	7231

All weights are approximate values and are based on machines equipped with rinsing tank, clean water tank, HARDI FILLER and suspended axle.



# Technical specifications

## Weight

CM plus 3200 HAY/HAZ						
	Empty			Full		
Boom width (m)	Axle load (kg)	Drawbar load (kg)	Own weight (kg)	Axle load (kg)	Drawbar load (kg)	Total weight (kg)
18	3577	598	4175	6886	1535	8421
20	3588	602	4190	6897	1538	8435
21	3603	607	4210	6912	1543	8455
24	3633	617	4250	6942	1553	8495
27	3697	638	4335	7006	1575	8581
28	3707	643	4350	7016	1579	8595

CM plus 4200 HAY/HAZ						
	Empty			Full		
Boom width (m)	Axle load (kg)	Drawbar load (kg)	Own weight (kg)	Axle load (kg)	Drawbar load (kg)	Total weight (kg)
18	3609	606	4215	7730	1535	9265
20	3620	610	4230	7742	1538	9280
21	3636	614	4250	7757	1543	9300
24	3666	624	4290	7787	1553	9340
27	3729	646	4375	7850	1575	9425
28	3740	650	4390	7861	1579	9440

All weights are approximate values and are based on machines equipped with rinsing tank, clean water tank, HARDI FILLER and suspended axle.

**For SELF TRACK models the values in above tables must be increased:**

+ 100 kg on Drawbar and Total weights

**For COMMANDER models *without* suspended axle, subtract:**

COMMANDER 2200/2800 - 220 kg (own weight)

COMMANDER 3200/4200 - 250 kg (own weight)

**Ground clearance (under axle):**

COMMANDER 2200/2800 without suspension: appr. 700 mm with suspension: appr. 600 mm

COMMANDER 3200/4200: without suspension: appr. 700 mm with suspension: appr. 750 mm

P.T.O. Power consumption		
Boom size	kW	Hp
18 m	34	46
20 m	42	57
21 m	42	57
24 m	54	73
27 m	54	73
28 m	54	73

The power consumption is stated at a working pressure of 10 bar.

# Technical specifications

## Pump capacity

### mump 363/10.0 (540 r.p.m.)

Rotation per min.	200	300	400	500	540	600
bar	Capacity l/min					
0	73	107	141	178	194	211
2	72	105	140	175	189	207
4	71	103	139	172	186	205
6	70	102	138	169	184	203
10	68	100	135	166	182	200
15	66	98	132	164	178	197
Max. pressure: 15 bar		Weight: 52.5 kg		Suction height: 0.0 m		

### mump 363/5.5 (1000 r.p.m.)

Rotation per min.	200	300	400	500	600	700	800	900	1000
bar	Capacity l/min								
0	-	61	82	103	123	144	164	186	201
2	-	59	79	100	119	140	160	179	191
4	-	58	78	98	117	138	155	176	188
6	-	57	76	96	115	134	153	173	186
10	-	55	74	94	112	130	148	168	180
15	-	53	72	89	108	126	144	163	174
Max. pressure: 15 bar		Weight: 52.6 kg			Suction height: 0.0 m				

### mump 463/10.0 (540 r.p.m.)

Rotation per min.	200	300	400	500	540	600
bar	Capacity l/min					
0	109	156	207	257	276	305
2	103	152	202	252	270	299
4	101	149	198	246	265	295
6	99	146	195	242	263	289
10	94	142	192	236	256	282
15	91	136	184	230	248	276
Max. pressure: 15 bar		Weight: 66.5 kg		Suction height: 0.0 m		

### mump 463/5.5 (1000 r.p.m.)

Rotation per min.	200	300	400	500	600	700	800	900	1000
bar	Capacity l/min								
0	61	89	119	148	178	206	233	273	305
2	56	84	113	140	168	197	222	252	278
4	54	82	108	137	162	190	216	244	273
6	52	78	105	131	158	185	211	239	269
10	49	74	100	126	151	178	202	229	257
15	46	70	95	120	145	171	195	219	246
Max. pressure: 15 bar		Weight: 66.5 kg			Suction height: 0.0 m				

# Technical specifications

## Filters and nozzles

### Filter gauze width

30 mesh: 0.58 mm      50 mesh: 0.30 mm  
80 mesh: 0.18 mm      100 mesh: 0.15 mm

## Temperature and pressure ranges

Operating temperature range:  
2° to 40° C. (36°F to 104°F)

Operating pressure for safety valve:  
15 bar (220 psi)

Max. pressure on the pressure manifold:  
20 bar (290 psi)

Max. pressure on the suction manifold:  
7 bar (100 psi)

## Brakes

Max. wear rates on brake components, mm (in):

	2200/2800	3200/4200
Max. drum diameter A	302 (11.8897)	402 (15.8388)
Min. lining thickness B	2.0 (0.07874)	4.0 (0.15748)

### Hydraulic brakes

Max. hydraulic pressure: 150 bar (2176 p.s.i.)

### Air brakes, single line:

Air pressure, relieved brakes: 5.3 - 5.6 bar  
Air pressure drop to activate: 0.8 - 1.3 bar

### Air brakes, dual line

Load apportioning valve pressure settings:

Relieved: 0 bar  
Empty: 1.6 bar (23.2 p.s.i.)  
Half: 3.4 bar (49.3 p.s.i.)  
Full: Air tank pressure

## Materials and recycling

Tank: HDPE  
Hoses: PVC  
Valves: mainly glass-filled PA.  
Fittings: PA

### Disposal of the sprayer

When the equipment has completed its working life, it must be thoroughly cleaned. The tank, hose and synthetic fittings can be incinerated at an authorised disposal plant. The metallic parts can be scrapped. Always follow local legislation regarding disposal.

## Conversion factors, SI to Imperial units

All units used in this manual are SI units. In some occasions Imperial units are used. Use following factors to convert SI units to Imperial units:

	SI unit	Imperial unit	Factor
Weight	kg	lb.	x 2.205
Surface area	ha	acres	x 2.471
Length	cm	in	x 0.394
	m	ft	x 3.281
	m	yd	x 1.094
	km	mile	x 0.621
Velocity	km/h	mile/h	x 0.621
	km/h	m/s	x 0.277
Quantities/area	l/ha	gal (Imp.) /acre	x 0.089
Volume	ml	fl. oz (Imp.)	x 0.0352
	l	Imp. pt.	x 0.568
	l	gal (Imp.)	x 0.22
Pressure	bar	lb./in <sup>2</sup> (p.s.i.)	x 14.504
Temperature	°C	°F	(°C x 1.8) + 32
Power	kW	hp	x 1.341
Torque	Nm	lbft	x 0.74

## Electrical connections

### Rear lights

Position	Wire colour
1. LH direction indicator	Yellow
2. Free	Blue
3. Frame	White
4. RH direction indicator	Green
5. RH rear position lamp	Brown
6. Stop lamps	Red
7. LH rear position lamp	Black

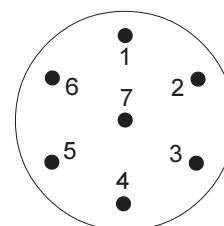

The wiring is in accordance with ISO 1724.

# Technical specifications

## Electrical connections for EVC operating unit

20 poled plug with cable

Number of distribution valve										
8	7	6 & 5	4	3 & 2		2 & 3	4	5 & 6	7	8
Wire number or colour code										
8										G/Y
9	9	13	9	9		10	10	14	10	10
	8	G/Y	G/Y	G/Y		11	11	15	G/Y	
7	7								17	17
6	6	1	1				2	2	16	16
5	5	3	3	1		2	4	4	15	15
4	4	5		3		4		6	14	14
3	3	7	5	5		6	6	8	13	13
2	2	9	7				8	10	12	12
1	1	11						12	11	11

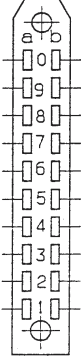

G/Y = green/yellow

## EVC

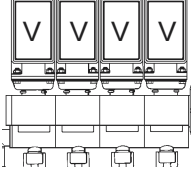
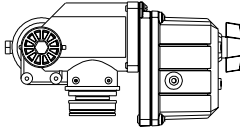
armatur EC 2B(L) T192-0037.dxf

Number of distribution valves				
	2/3/4	5/6	7	8
Valve	Wire number or color code			
V1	1-2	1-2	1-11	1-11
V2	3-4	3-4	2-12	2-12
V3	5-6	5-6	3-13	3-13
V4	7-8	7-8	4-14	4-14
V5		9-10	5-15	5-15
V6		11-12	6-16	6-16
V7			7-17	7-17
REG	9-10	13-14	9-10	9-10
V8	?	?	?	8-G/Y

G/Y = Green/Yellow

The EVC operating unit fulfils the EC noise reduction standards.

## Electrical chart (EVC)

# Technical specifications

## Installation instruction for boom and work light

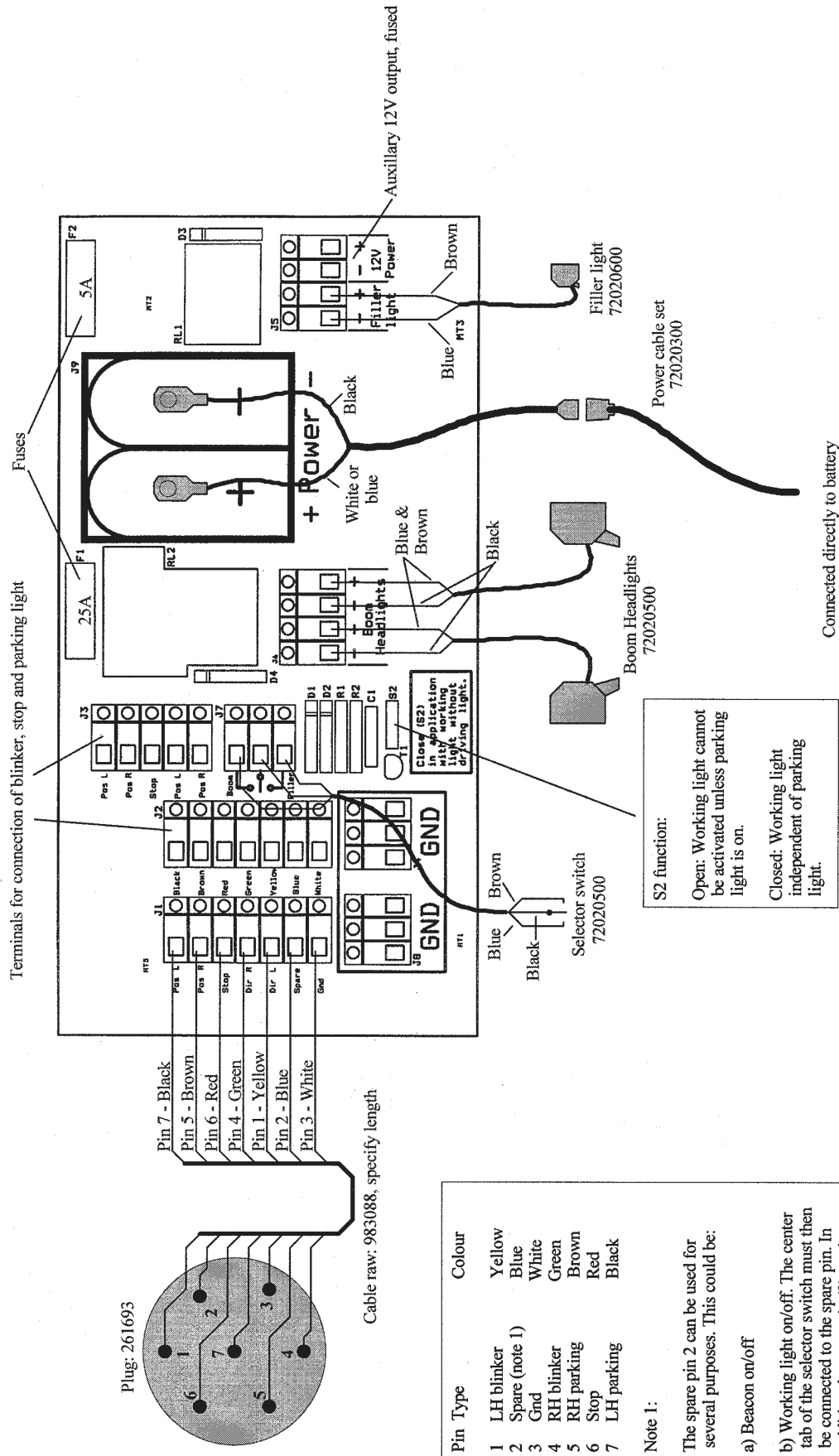

# Technical specifications

## Electrical specifications for Boom and Work light

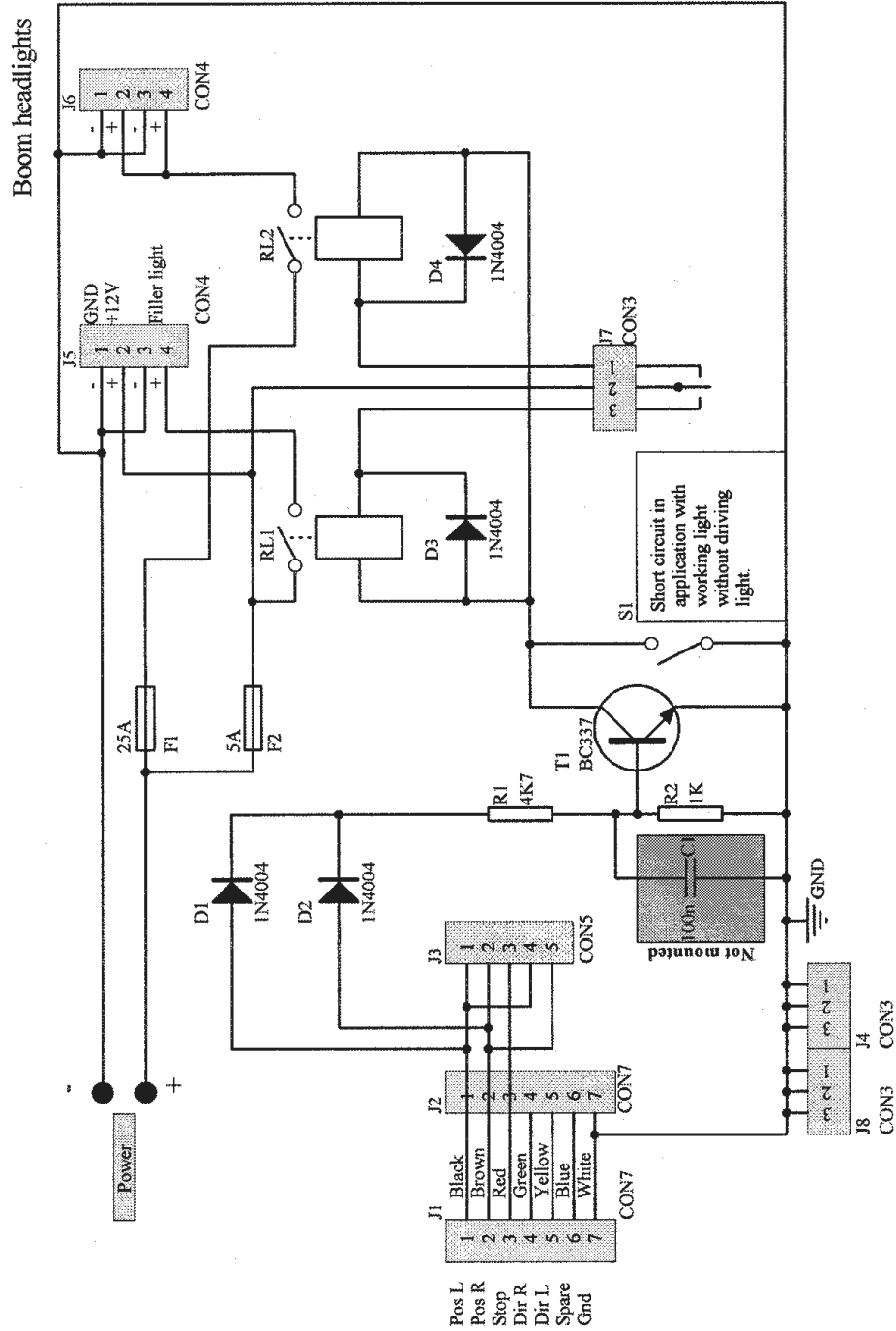

T058-0016



# Technical specifications

---

## Boom hydraulic charts

Illustrations still missing

## Subject Index

### A

Air activated brakes 18  
Air assistance 43  
Air brake filters 63  
Air in system 78  
Air speed 43  
Air technique 43  
Air volume 43  
Altering track gauge 15  
Angling of air and liquid 43  
Anti-freeze 76  
Application zone 6  
AXIAL connection 71

### B

Ball valve 37  
Ballast 77  
Black disc 32  
Blower adjustment 43  
Blown fuse 82  
Boom light 26  
Boom slow/eradic 79  
Brakes 18  
Break-away 64

### C

CaCl<sub>2</sub> 20  
Centre rim 15  
Chemicals 38, 42  
Circuit leak 77  
Clean water tank 36  
Clean zone 6  
Cleaning the sprayer 49  
Colour codes 43  
Cone 68  
Connection box 26  
Conversion factors 86  
Counter weight 20  
Crop protection Kit 27

### D

D.A.H. system 16  
Damping pressure setting 70  
Diaphragm 68  
Disconnecting 29  
Disposal of pesticides 49  
Distribution block 16  
Drawbar 9  
Drawbar extension 9  
Driving Technique 23  
Dual-line brakes 19

### E

EC Declaration 4  
EVC operating unit 34, 36, 87  
Emergency brake 18  
Emergency operation of the sprayer 82  
Expansion bottle 60, 63

### F

Fan speed 43  
Fast Filling Device 34  
Filling 33  
Filling of chemicals 38  
Filling of water 33  
Filter gauze 58  
Filters 7, 37  
Fittings 71  
Fixed drawbar 10  
Formation of foam 78  
Frame 7  
Front Locker 25  
Function diagram 32  
Fuse 82  
Fuse type 82

### d

Green disc 32  
Guide rods 64

### H

HARDI FILLER 38  
HARDI-MATIC 7  
Hitch (ISO 5692) 9  
Hub flange 15  
Hydraulic activated brakes 18  
Hydraulic brakes 63  
Hydraulic circuit 63  
Hydraulic systems 16

### I

Identification plates 7  
Imperial units 86  
In-Line filter 58  
Inner section 64

### J

Junction box 82

### i

Lack of pressure. 78  
Ladder 25

Large storage Locker 25  
Level indicator 71  
Lifting points 8  
Liquid chemicals 38  
Liquid leaks 78  
Liquid-filled tyres 20  
Load Sensing 16

## **M**

Maintenance 49  
MANIFOLD SYSTEM 32  
Max. pressure 86  
Maximum track width 14  
Minimum track width 14  
Mudguard 28  
Multi plug 82

## **N**

No spray from boom 78  
Nominal contents 7  
Nozzle filters 58  
Nozzle tube 71  
Nozzles 86

## **I**

O-ring 71  
Off-season storage 76  
Oil heats up 80  
Operating pressure 86  
Operating temperature 86  
Operating unit 7  
Operational problems 77  
Operator safety 5  
Outer section 64

## **m**

P.T.O. shaft 7, 11  
Parking brake 18, 29, 62  
Pendulum return spring and cables 64  
Personal protection 42  
Pesticide washings 49  
Powder chemicals 39  
Power failure 82  
Power supply 17  
Pressure gauge 37, 43  
Pressure increasing 78  
Pressure range 86  
Pressure valve 32  
Product Identification Certificate 4  
Protection film 8  
Protective clothing 49  
Pump 7  
Pump capacity 85

Pump valves 68  
PVC sheet 27

## **Q**

Quick coupler 35

## **o**

RADIAL connection 71  
Ram not functioning 79  
Rear lights 25, 86  
Recycling 86  
Remote pressure gauge 37  
Replace tyres 73  
Restrictor 37  
Rinsing nozzles 40  
Rinsing tank 35, 40  
Rinsing tank drain valve 42

## **p**

Safe sprayers 49  
Safety valve 77  
Selector switch 26  
SELF TRACK 10, 23  
Self-cleaning filter 37  
Shipping package label 4  
Shock absorbers 70  
SI 86  
Single-line brakes 19  
Small storage Locker 25  
Soap dispenser 26  
Sprayer trails unstable 77  
Spraying circuit 58  
Stability 15  
STEER TRACK 23  
STEERING drawbar 10  
Stop wedges 29  
Strawdivider 27  
Suction Filling Device 34  
Suction filter 58  
Suction quick coupler 41  
Suction valve 32  
Support leg 29  
Swivel type 9

## **T**

Tank 7  
Tank drain valve 41  
Tank lid 33  
Technical Residue 41  
Temperature 86  
The work light 26  
TRAIL CONTROL 10  
Transmission shaft 11

Transmission shaft support 10, 29  
Transport lock 22  
Tyre 73  
Tyre pressure 60  
Tyre safety 82

## **U**

Unloading 8

## **t**

Water sensitive paper 45  
Wear bush 69  
Wear rates 86  
Wheel bearings 62  
Wheel bolts 60  
Wheel brake cover 27  
Wiring 21  
Working zone 6

## **Y**

Yellow MANIFOLD valve 37

## **w**

Zugmaul 9

