

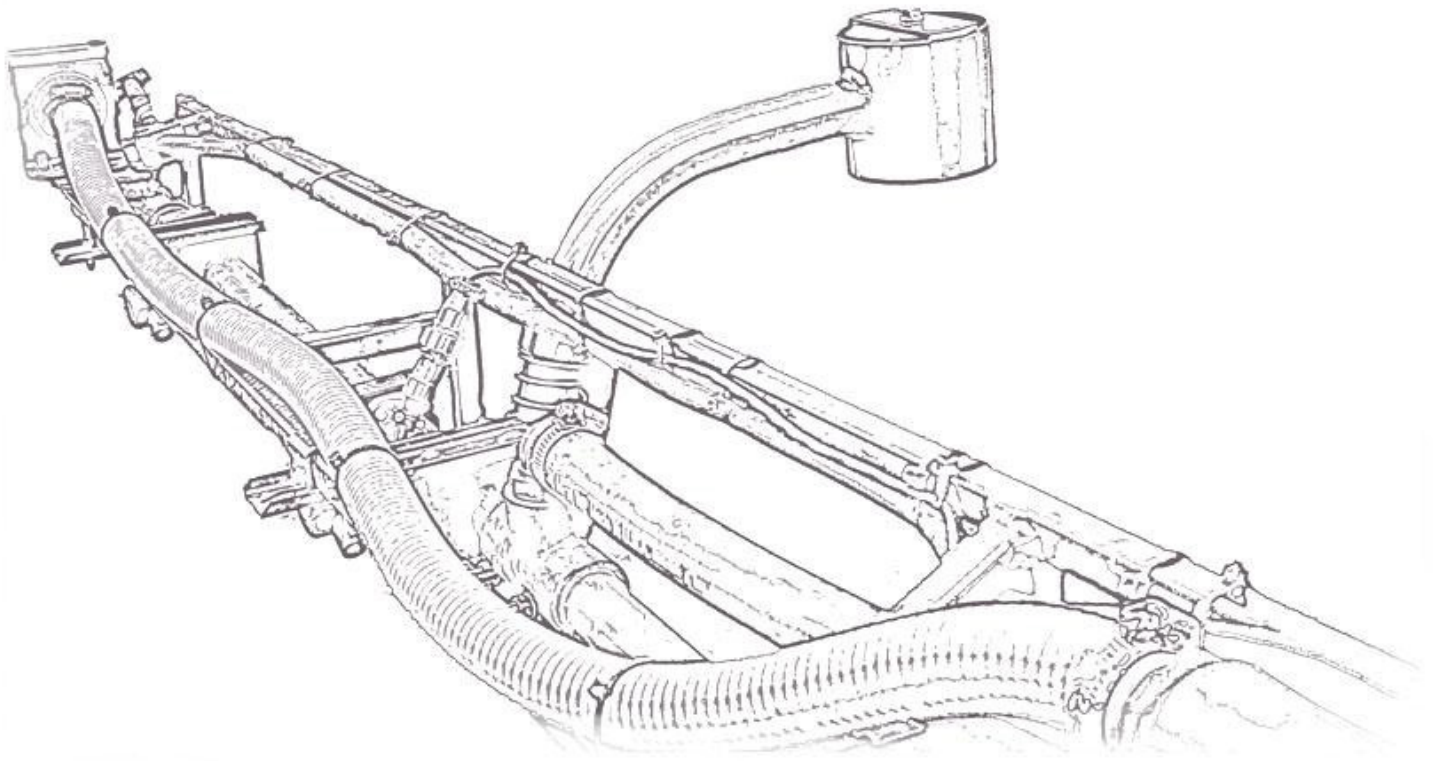

UC4+[™] Spray Height Controller
ROLL CONTROL
Patented



Hardi OEM

Installation Manual

Improving the competitiveness of Industry and
Agriculture through Precision Measurement

Printed in Canada

Copyright © 2005-08 by NORAC Systems International Inc.

Reorder P/N: UC4+BC+HD3-INST Rev C (Hardi OEM)

NOTICE

NORAC Systems International Inc. reserves the right to improve products and their specifications without notice and without the requirement to update products sold previously. Every effort has been made to ensure the accuracy of the information contained in this manual. The technical information in this manual was reviewed at the time of approval for publication.

TABLE OF CONTENTS

1	INTRODUCTION	1
2	GENERAL SYSTEM DESCRIPTION	2
3	PARTS LISTS	3
4	INSTALLATION PROCEDURE	7
4.1	EXISTING SYSTEM CHECK	7
4.2	BOOM SPEED TEST.....	7
4.3	ULTRASONIC SENSOR INSTALLATION.....	9
4.4	ROLL SENSOR INSTALLATION.....	12
4.4.1	<i>Boom Frame Roll Sensor Mounting.....</i>	<i>13</i>
4.4.2	<i>Chassis Roll Sensor Mounting.....</i>	<i>14</i>
4.5	HYDRAULIC INSTALLATION	15
4.5.1	<i>Valve Assembly.....</i>	<i>15</i>
4.5.2	<i>Valve Mounting.....</i>	<i>16</i>
4.5.3	<i>Hydraulic Plumbing</i>	<i>17</i>
4.6	ELECTRICAL INSTALLATION.....	18
4.7	COMPLETING THE FACTORY INSTALLATION	22
5	ELECTRICAL REFERENCE – CABLE DRAWINGS.....	23
5.1	ITEM C02: 44668 – SENSOR BRANCH CABLE.....	23
5.2	ITEM C02B: 44664 – CABLE UC4 CAN NODE DUAL.....	24
5.3	ITEM C03: 44656 – VALVE CABLE (VARIABLE RATE)	24
5.4	ITEM C10: 44650-35 – POWER GENERIC CABLE PULL-TYPE	25
5.5	ITEM C11: 44651-03 – VALVE EXTENSION GENERIC CABLE	26
5.6	ITEM C12: 44658-42 – INTERFACE CABLE AMP ML ONLY	27
5.7	ITEM C13: 44658-49 – VALVE CABLE ROLL PIGTAIL	28

1 INTRODUCTION

Congratulations on your purchase of the NORAC UC4+ Spray Height Controller. This system is manufactured with top quality components and is engineered using the latest technology to provide operating features and reliability unmatched for years to come.

When properly used the system can provide protection from sprayer boom damage, improve sprayer efficiency, and ensure chemicals are applied correctly.

Please take the time to read this manual completely before attempting to install the system. A thorough understanding of this manual will ensure that you receive the maximum benefit from the system.

YOUR INPUT CAN HELP MAKE US BETTER! If you find issues or have suggestions regarding the parts list or the installation procedure, please don't hesitate to contact us via the information given below:

Phone:	1-800-667-3921	Canada (Toll Free)
	1-866-306-6722	United States (Toll Free)
	0-800-404-8389	United Kingdom (Toll Free)
	1-306-664-6711	all other regions

E-mail: service@norac.ca

Website: www.norac.ca

2 GENERAL SYSTEM DESCRIPTION

Figure 1 depicts the general system layout of the UC4+ Spray Height Control system.

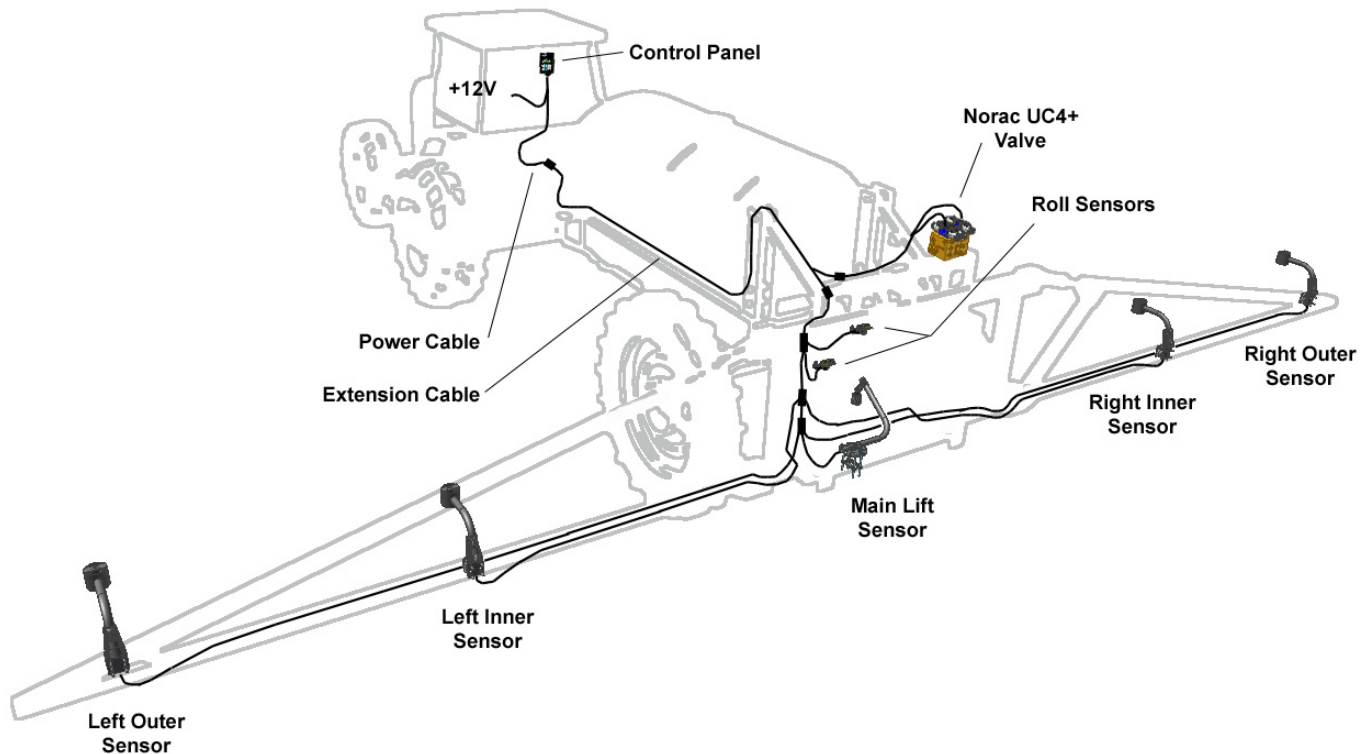

Figure 1 – System Components and General Location

⚠ NOTICE:

Every effort has been made to ensure the accuracy of the information contained in this manual. All parts supplied are selected specially to fit the sprayer to facilitate a complete installation. However, NORAC cannot guarantee all parts fit as intended due to the variations of the sprayer by the manufacturer. **Please read this manual in its entirety before attempting installation.**

⚠ ATTENTION:

When installing the UC4+ Spray Height Control system please be aware that at a point in the installation your sprayer booms will be inoperative until the installation is complete. **Any installation procedure requiring boom movement will need to be done first.** Once the hydraulics have been disconnected you must complete the electrical installation before the booms become operative.

3 PARTS LISTS



The parts that come with your UC4+ Sprayer Boom System are listed in **Table 1**. The item number on the left side of this table references each part.

Please ensure that all parts in your kit are present before proceeding with your installation.

Table 1 – Hardi OEM Spray Height Control System Parts (Rev C)

Item	Part Number	Name	Quantity
B10	44700-06	BRACKET VALVE MOUNTING STD	1
B13	44728	MOUNTING BRACKET COMPLETE UC4 BREAKAWAY EXTENDED	2
C02	44668	CABLE UC3 SENSOR BRANCH 1 AMP RECEPT 3 AMP PLUG BC	1
C02B	44664	CABLE UC4 CAN NODE DUAL	1
C03	44656	CABLE VALVE VARIABLE RATE	1
C10	44650-35	CABLE POWER GENERIC PULL-TYPE	1
C11	44651-03	CABLE EXTENSION VALVE GENERIC	1
C12	44658-42	CABLE INTERFACE UC4 BC C12 AMP ML ONLY	1
C13	44658-49	CABLE VALVE UC4 BC C5 ROLL PIGTAIL	1
E01	4461BC+HD	UC4 PLUS BOOM CONTROL PANEL HARDI	1
E02	44631	UC4 ULTRASOUND SENSOR	3
E03	44641	UC4 PLUS ROLL SENSOR W TEMPERATURE PROBE	1
E04	44642	UC4 PLUS ROLL SENSOR	1
H20	44865-12	HYDRAULICS FITTING KIT - HD3	1
M01A	446BC+MAN6-1	MANUAL UC4+ BOOM CONTROL 2008 OPERATORS SMALL BOOKLET	1
M01B	446BC+MAN6-2	MANUAL UC4+ BOOM CONTROL 2008 QUICK REFERENCE SMALL BOOKLET	1
M10	UC4+BC+HD3-INST	MANUAL INSTALLATION UC4+ HARDI	1
M13	UC4-BC-HD3-INSTE	MANUAL INSTALLATION END-USER HARDI	1
V01	44933S	VALVE BLOCK ASSEM UC4-BC 2-STATION CC/LS VARIABLE RATE	1

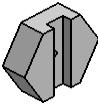
Table 2 - 44865-12 (Rev C) - Hydraulics Fittings Kit Details

Item	Part Number	Name	Quantity	Picture
F01	44928	ORIFICE INSERT .047 IN ONE WAY	4	
F02	501301	MALE ADAPTER - 6MB 6MBSPP	4	
F03	104369	PLUG - 6MBP	2	

Fitting Name
Example:

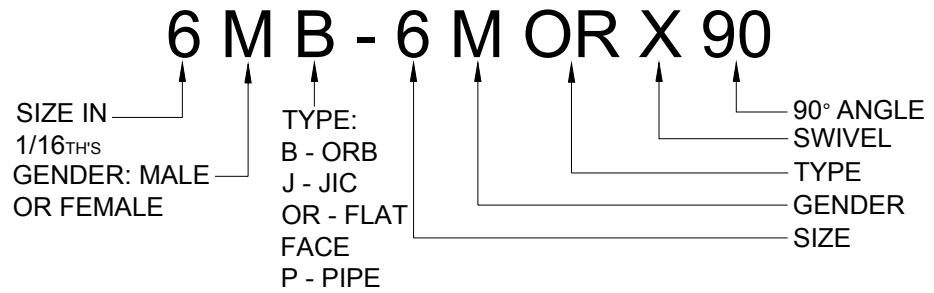

The parts that come with your UC4+ Spray Height Control system are shown below in their general installation configuration.

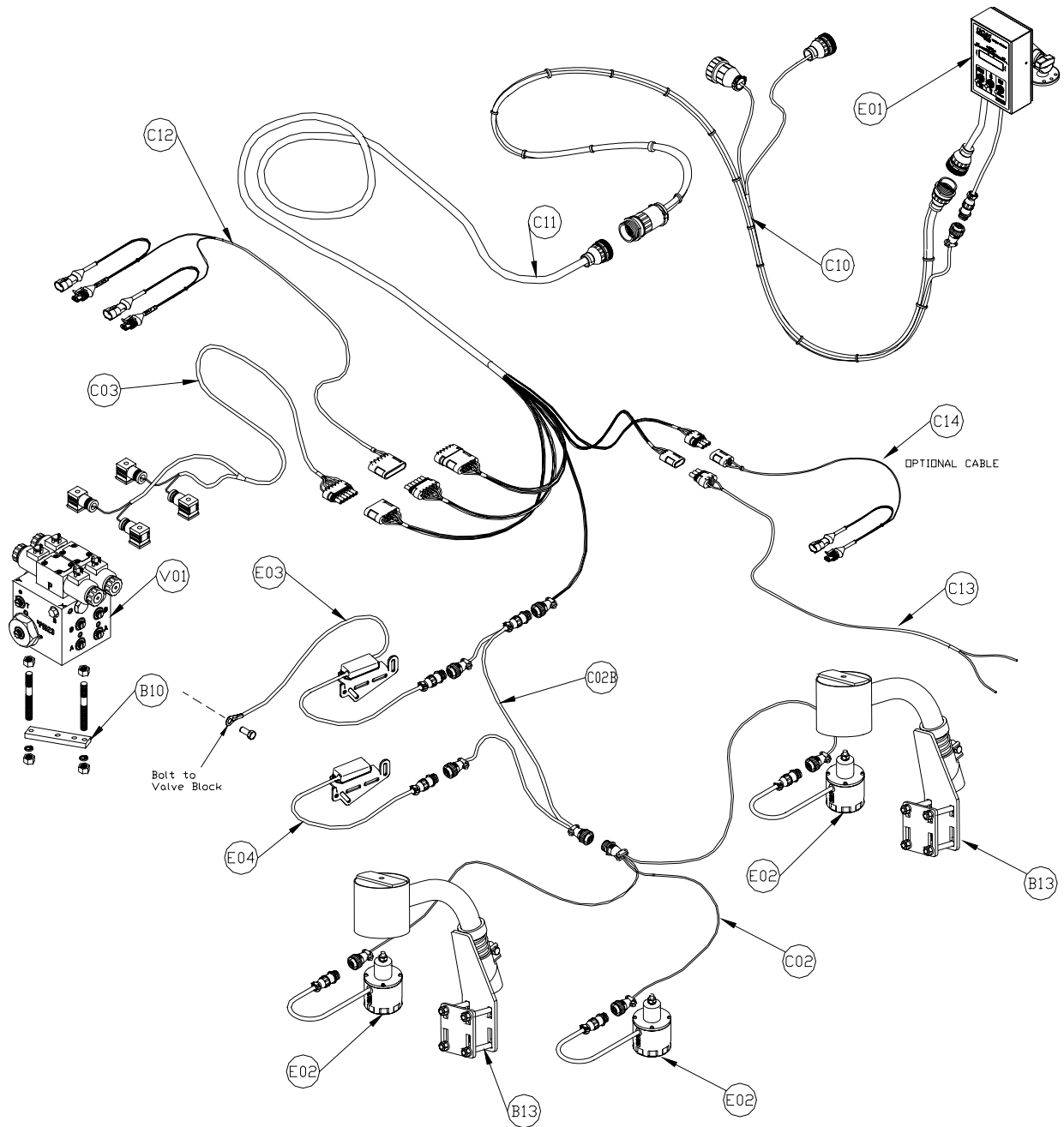

Figure 2 – UC4+ Spray Height Control Components

⚠ If your sprayer comes equipped with a bypass valve, you will need to order cable C14 (optional bypass interface cable PN 44658-60). See section 5.8 for cable information.

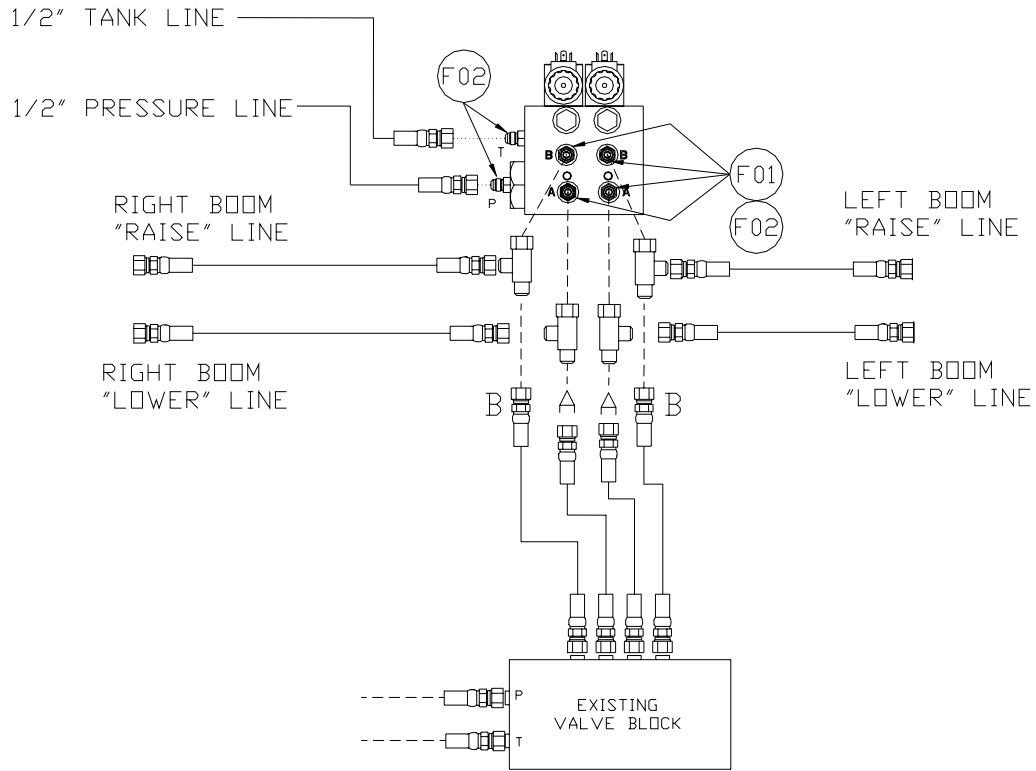

Figure 3 – Hydraulic Components – Double Acting

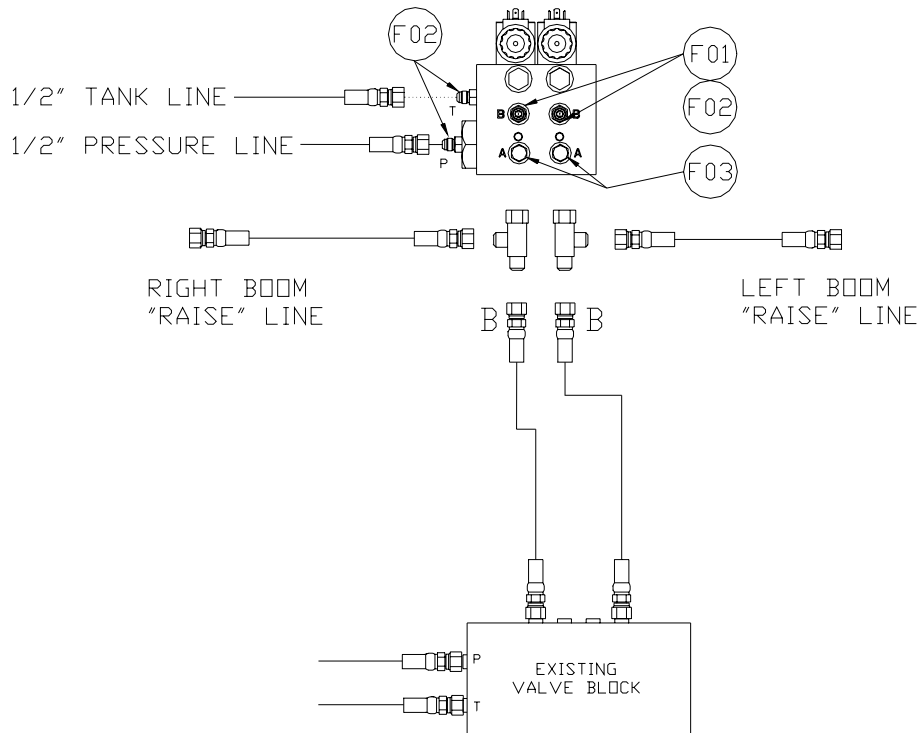

Figure 4 – Hydraulic Components – Single Acting

4 INSTALLATION PROCEDURE

4.1 EXISTING SYSTEM CHECK

It is necessary to check the existing system’s functionality before installing the UC4+ Spray Height Control system.

1. Drive your sprayer onto a flat piece of land, with unobstructed boom movement (e.g. no power lines).
2. Test that all boom functions operate correctly. As you test each function check it off in **Table 3**.

 **It is necessary to test the boom functions in all directions**

Table 3 – Hydraulic System Function Check Sheet

BOOM	FOLD IN	FOLD OUT	UP	DOWN
LEFT				
MAIN				
RIGHT				
ROLL*	N/A	N/A		

* Some sprayers may not have this function.

4.2 BOOM SPEED TEST

 **IMPORTANT:**

Raise/lower all boom sections several times to warm up the hydraulic system. Grease all moving parts for consistent results.

3. Lower each boom and main section as close to the ground as possible.
4. Set your sprayer at field working RPM on the throttle and mark this value in **Table 4**.

 **You will need a stopwatch or a watch that displays “seconds” for the next step.**

5. Raise the LEFT boom from its extreme LOW position to the very TOP of its travel. Record the time this takes in **Table 4**, “Trial #1” for “Left UP”.
6. Lower the LEFT boom from its extreme HIGH position to the BOTTOM of its travel. Record this time in **Table 4**, Trial #1, for “Left DOWN”.

 **Be careful when lowering the booms so they don’t hit the ground.**

7. Similarly, record two more time trials (Trial #2 & #3) for the LEFT boom and record in **Table 4**
8. Repeat **Steps 3** through **7** for the RIGHT, MAIN and ROLL functions.

 **Your sprayer may not have a roll feature.**

9. Average the three trials recorded for each boom movement and record this calculation in the “Average Time” slot in **Table 4**.
10. These “Average Times” now represent how quickly your system can react to manual control. In **Section 1.1**, this procedure is repeated with the UC4+ Spray Height Control system installed for comparison and troubleshooting purposes.

Table 4 – Boom Test Record (WITHOUT UC4+ Spray Height Control system)

Working RPM:				
<u>Boom</u>	<u>Trial #1</u> [Sec]	<u>Trial #2</u> [Sec]	<u>Trial #3</u> [Sec]	<u>Avg Time</u> [Sec]
Left UP				
Left DOWN				
Right UP				
Right Down				
Main UP				
Main DOWN				
Roll CW				
Roll CCW				

Table 5 – Boom Test Record (WITH UC4+ Spray Height Control system)

Working RPM:				
<u>Boom</u>	<u>Trial #1</u> [Sec]	<u>Trial #2</u> [Sec]	<u>Trial #3</u> [Sec]	<u>Avg Time</u> [Sec]
Left UP				
Left DOWN				
Right UP				
Right Down				
Main UP				
Main DOWN				
Roll CW				
Roll CCW				

 **Some sprayers may not have the Roll functions.**

4.3 ULTRASONIC SENSOR INSTALLATION

1. Assemble the Breakaway Sensor Mounting Brackets (B11) as show in **Figure 5** and **Figure 6**.

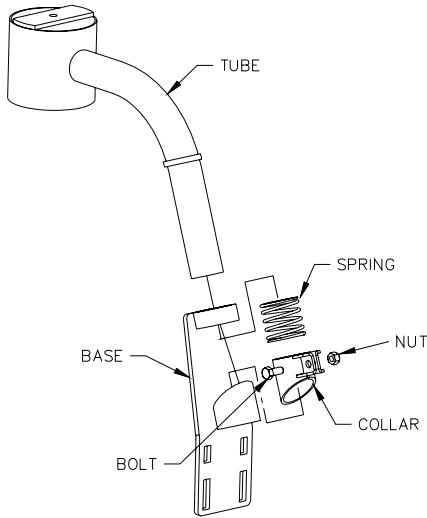

Figure 5 – Breakaway Sensor Bracket Exploded View

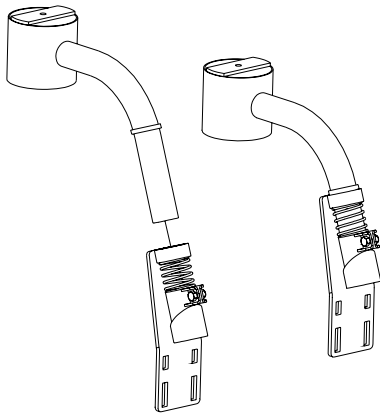

Figure 6 – Breakaway Sensor Mounting Bracket Assembly

To assemble the breakaway sensor bracket:

- a) Assemble the bolt and nut into the collar.
- b) Grease the bottom edge of the collar and the angled tube of the base.
- c) Place the collar onto the angled tube of the mounting base.

- d) Install the spring between the collar and the upper ring of the base.
- e) Insert tube through assembly and tighten the collar

2. Mount the sensor bracket onto the boom.

! If possible, mount the sensor brackets while the booms are in their folded position to ensure that they will not interfere with anything when the boom is folded for transport.

3. The sensor mounting brackets can be installed with the base behind (**Figure 9**) or in front of the tube (**Figure 7**).

! It is advised to avoid mounting the sensor bracket to a breakaway portion of the boom because a breakaway action can cause the UC4+ Spray Height Control system to force a boom close to the ground. Please refer to the UC4+ Spray Height Control system warranty at the end of the UC4+ Spray Height Control Operator's Manual (M01) for implications.

4. Mount the NORAC UC4+ ultrasonic sensor (E02) into the sensor brackets. The sensors should be oriented forward (ahead) of the boom (**Figure 7** and **Figure 9**).

! When installing the UC4+ sensors (E02), start with the smallest serial number on the left hand side proceeding to the largest serial number on the right hand side (**Figure 10**).

5. Sensor cables should run through the mounting bracket tube and then behind the member the bracket is mounted onto. Cable-tie the connector in place. The cable must not be allowed to hang below the boom (Figure 7).

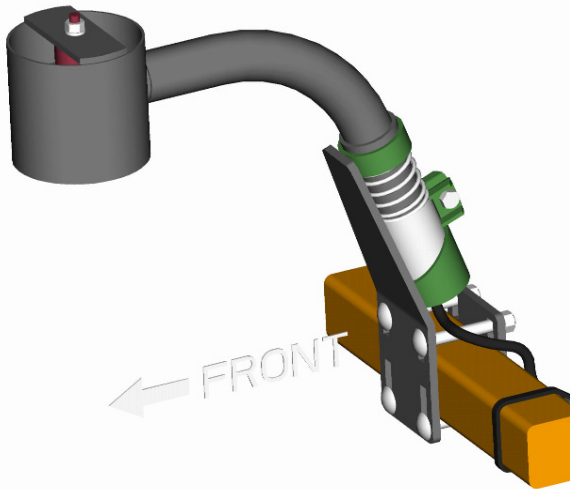

Figure 7 – Another Acceptable Mounting

⚠ Avoid mounting sensors in locations where they may read from parts of the boom as shown in Figure 8.

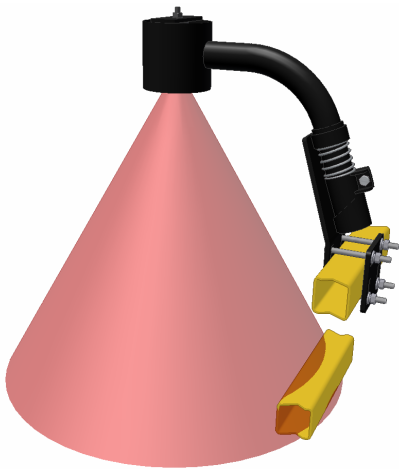

Figure 8 – Poor Mounting (Sensor reading off boom)

General mounting rules for UC4+ ultrasonic wing sensors:

- a) In its lowest position, the sensor mouth must be 9 inches or more from the ground.
- b) The bottom of the sensor must be at least 9 inches in front of the spray nozzles.
- c) The bottom of the sensor must be at least 9 inches above the spray nozzles.
- d) Ensure that there are no obstructions within a 12-inch diameter circle projected directly below the center of the sensor.
- e) The sensor should be approximately vertical at normal operating heights.

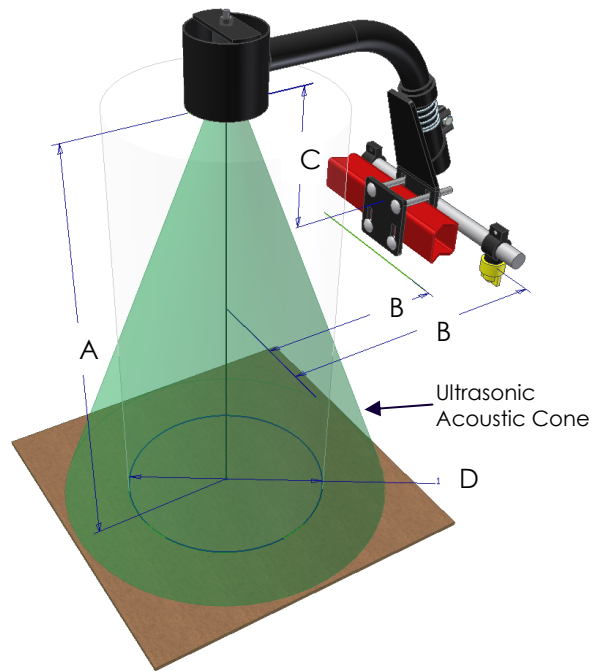
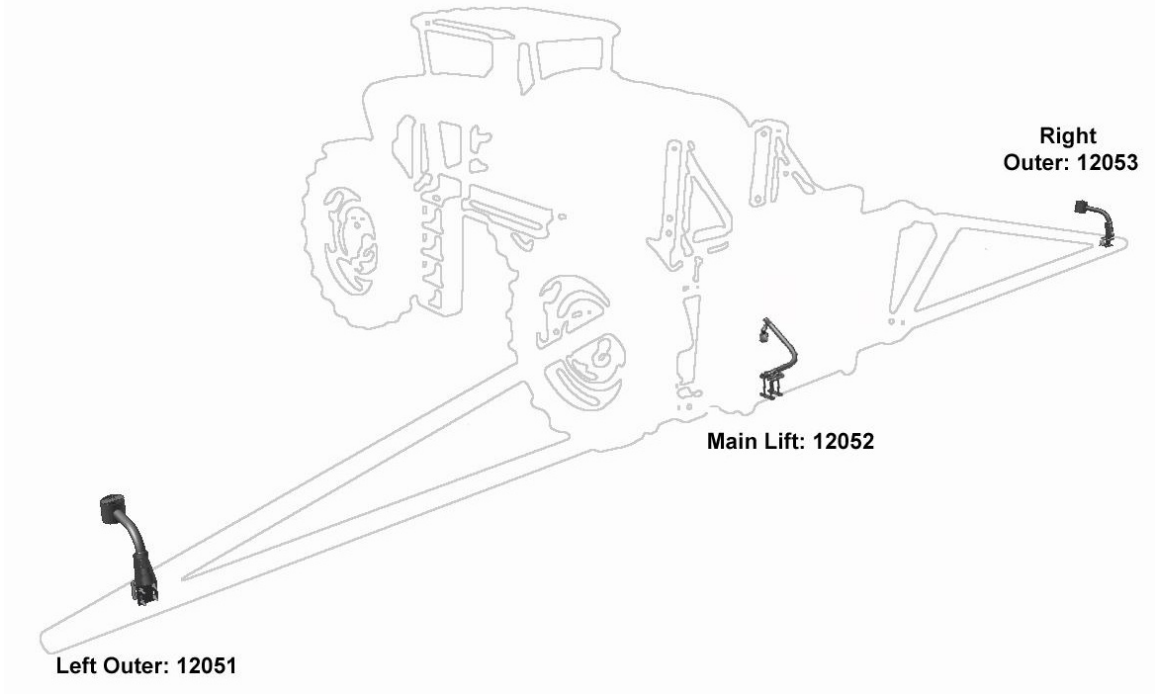

Figure 9 – Sensor mounting guidelines

3 SENSOR SYSTEM



5 SENSOR SYSTEM

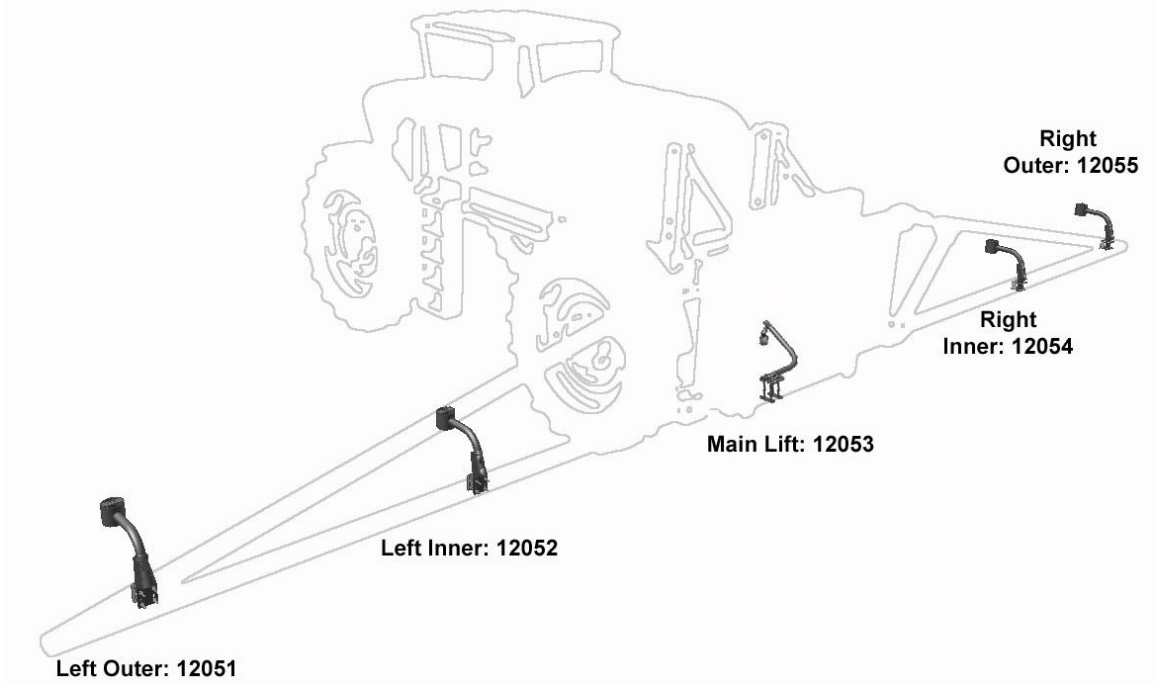

Figure 10 – Sensor Serial Number Installation Location

4.4 ROLL SENSOR INSTALLATION

Mount the roll sensors to the included roll sensor brackets using the machine screws and nylon lock nuts, as illustrated in **Figure 11**.

⚠ The roll sensors must be mounted tightly to the brackets.

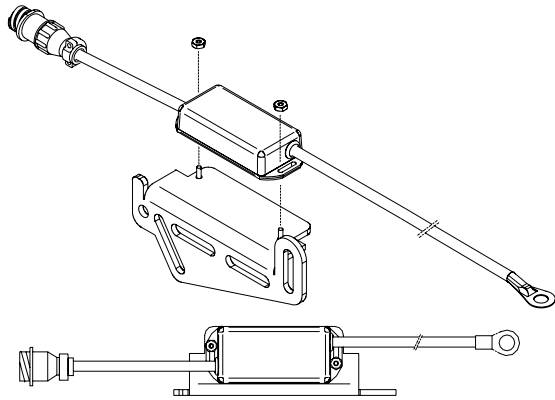

Figure 11 – Mounting the roll sensor to the roll sensor mounting bracket

When mounting the roll sensors, use the following guidelines and refer to **Figure 12**.

- The smaller the distance between **A** and **B** in **Figure 12**, the better the performance will be.
- Ensure the roll sensors are sitting relatively level when the sprayer chassis and boom are level.
- Both roll sensors must be mounted with the circular AMP connector facing towards the Right-Hand Wing (when looking from the rear of the sprayer).

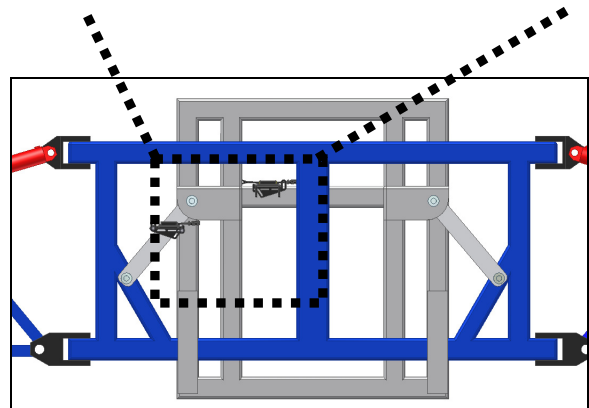
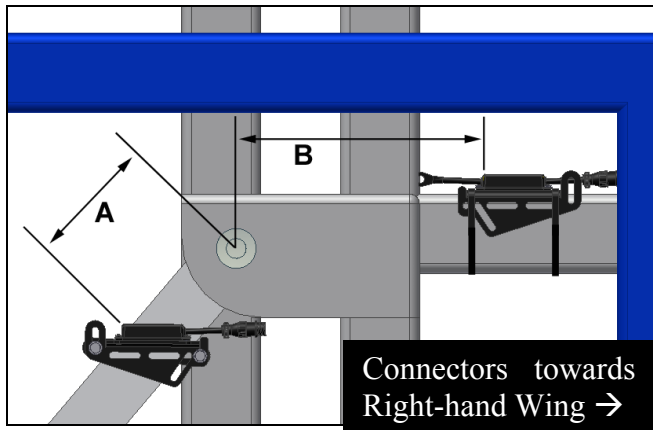
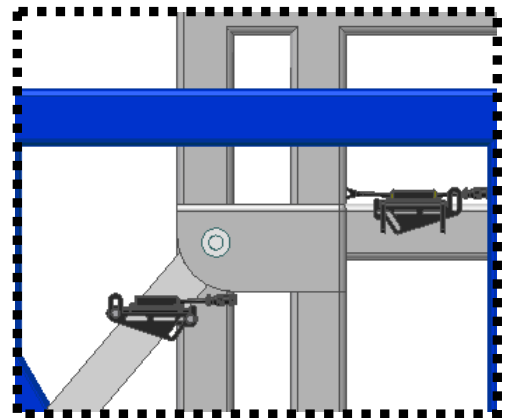

Figure 12 – General Roll Sensor mounting location on a Trapeze style boom

4.4.1 Boom Frame Roll Sensor Mounting

1. Use the supplied hardware to mount the boom frame roll sensor (E04) as shown in **Figure 13**.

When mounting the boom frame roll sensor follow these guidelines:

- a) To prevent bending the bracket, ensure bolts are placed as close together as possible (minimize C in **Figure 13**).
 - b) Be sure to use the roll sensor without the temperature probe (E04).
 - c) When the boom is centered (not rolled over) the roll sensor should be level with respect to the sprayer chassis.
 - d) It is best to mount the roll sensor to the left hand trapeze link (when looking from the rear of the sprayer).
 - e) The roll sensor AMP (circular) connector **MUST exit towards the right hand wing** (when looking from the rear of the sprayer).
2. Cable-tie the sensor connector to the frame with enough slack to allow the link to rotate.

⚠ Make sure the bracket does not collide with any parts of the sprayer when the boom rotates. Also ensure there is enough slack to allow the roll sensor to rotate.

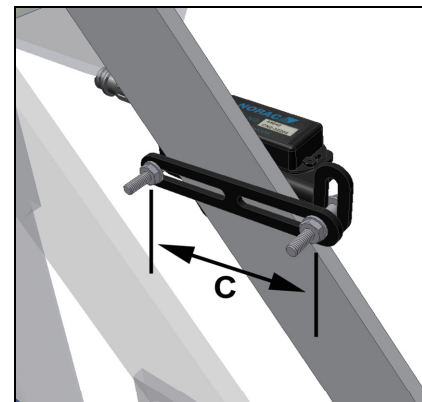
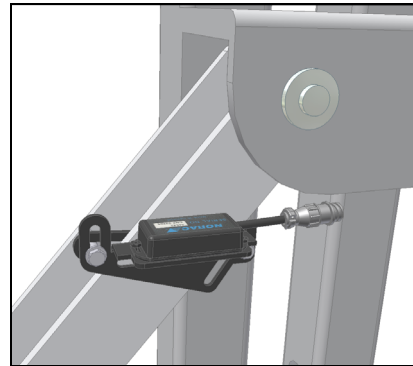

Figure 13 – Boom frame roll sensor mounted to a trapeze link

4.4.2 Chassis Roll Sensor Mounting

1. It is often best to cable tie the chassis roll sensor in place. When mounting the chassis roll sensor follow the guidelines and refer to **Figure 14**.

! The chassis roll sensor must be mounted on a portion of the sprayer that does not pivot and is as close to the boom frame roll sensor as possible (**Figure 12**).

- a) Make sure you are using the roll sensor with the temperature probe (**E03**).
- b) Ensure the roll sensor is level with respect to the chassis.
- c) The AMP (circular) connector **MUST exit towards the right hand wing**.
- d) Make sure the temperature probe is able to reach the side of the valve block.

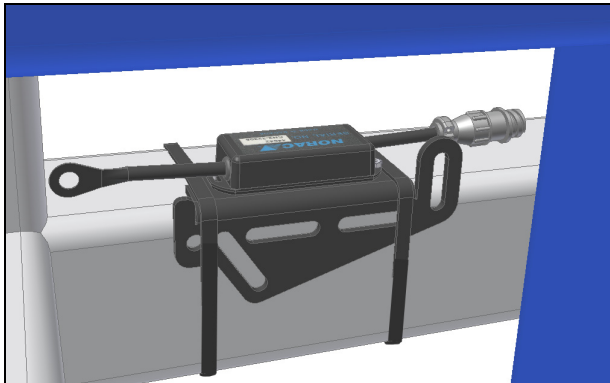

Figure 14 – chassis roll sensor mounting

2. Fasten the temperature probe to the UC4+ valve block, using the supplied 3/8"x1/2" bolt as shown in **Figure 15**.
3. Cable-tie the temperature probe cable and AMP (circular) connector securely to a frame member.

! Check that the roll sensors and cables will not interfere with, or come into contact with any parts of the sprayer.

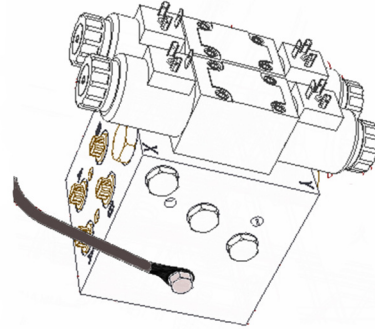

Figure 15 – Temperature probe attached to the UC4+ valve block

4.5 HYDRAULIC INSTALLATION

WARNING!

The hydraulic system creates very high pressure. Before disconnecting any hydraulic lines ensure all pressure has been bled from the system. When changing the boom hydraulic hoses leave the booms in TRANSPORT POSITION.

IMPORTANT:

Component failure due to oil contamination is not covered under the UC4+ Spray Height Control system warranty. It is recommended that a qualified technician does the hydraulic installation.

4.5.1 Valve Assembly

1. On a clean surface remove all plastic plugs from the NORAC hydraulic Valve (V01) (Figure 16).

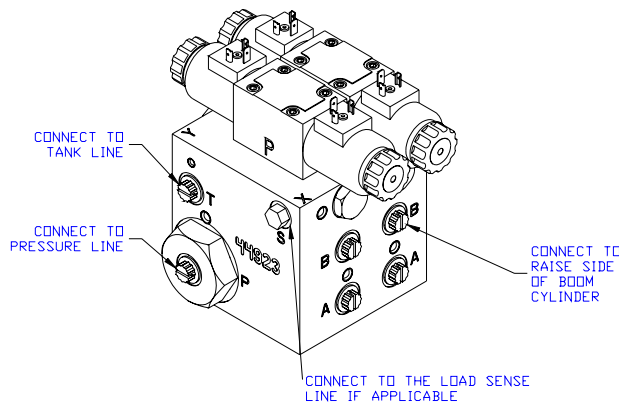

Figure 16 – NORAC Valve Block

2. Install the male adapters (F02) on the "P" and "T" ports and tighten to 18 ft-lbs.
3. At this point the sprayer hydraulic system must be identified as being single acting or double acting.

4.5.1.1 Double Acting Assembly

- 1) Install the orifices (F01) into the "B" ports with the notch facing outward as shown in Figure 17.
- 2) Install the orifices (F01) into the "A" ports with the notch facing inward as shown in Figure 17.
- 3) Install the male adapters (F02) into the ports and tighten to 18 ft-lbs.

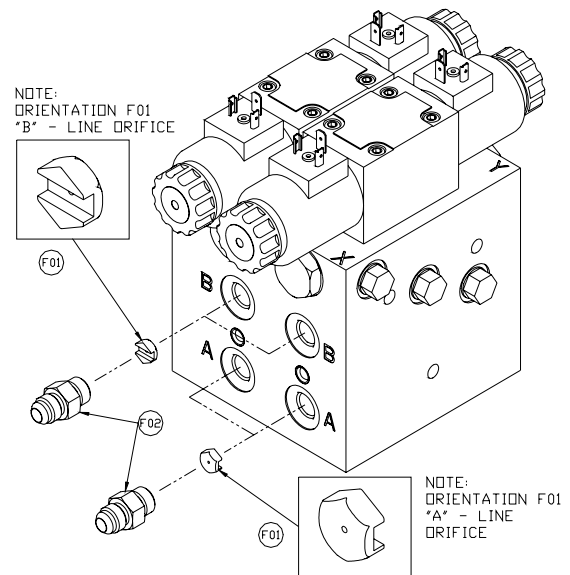

Figure 17 – Double Acting Valve Block Assembly

4.5.1.2 Single Acting Assembly

- 1) Install the orifices (F01) into the "B" ports with the notch facing outward as shown in Figure 18.
- 2) Install the male adapters (F02) into the "B" ports and tighten to 18 ft-lbs.
- 3) Install the plugs (F03) into the "A" ports and tighten to 18 ft-lbs.

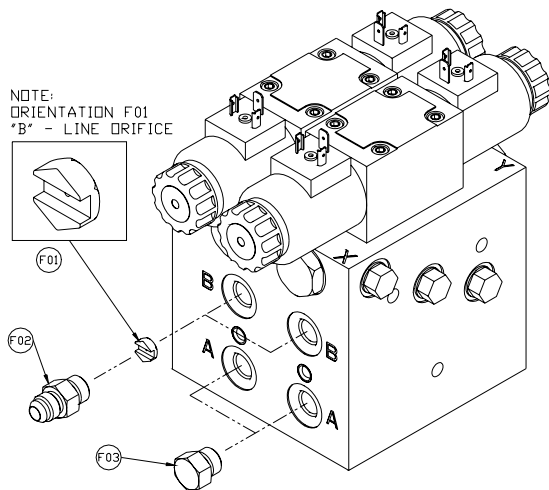

Figure 18 – Single Acting Valve Block

4.5.2 Valve Mounting

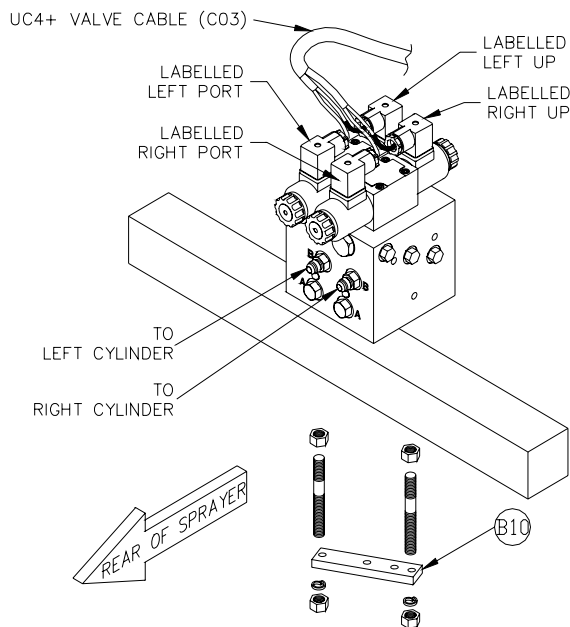

Figure 19 – Valve Mounting Location

1. Mount the NORAC valve (**V01**) on the sprayer using the valve mounting bracket (**B10**).
2. As shown in **Figure 19**, screw short side of the threaded rods into the bottom of the valve block at least 3/8". The valve

mounting holes are drilled and tapped 3/8 NC-1" deep.

3. Tighten the Hex nuts to hold the rods.
4. Put the mounting bracket on the other side of the tube and tighten with the spring washers and the Hex nuts.
5. Cut excess off of the rods, if necessary.

! If using bolts, the bolts should thread into the valve block at least 3/8". The valve mounting holes are drilled and tapped 3/8 NC-1" deep. The rule of thumb for bolt length is 1-1/2" longer than the tube size.

! The recommended mounting location is on the rear of the boom main section and on the vertical member centered below the Hardi valve block. Orient the valve block such that the "A" and "B" ports face downward.

! You must ensure no hydraulic components will interfere with any sprayer parts or be pulled tight at any time.

4.5.3 Hydraulic Plumbing



From this point in the installation the booms will be inoperative until the electronics are fully installed.

After the NORAC valves are mounted, the hydraulic hoses and fittings can be plumbed. The kit is designed to work with either single acting or double acting hydraulic circuits. The plumbing for the typical hydraulic circuit is shown in **Figure 3** and **Figure 4**.

4.5.3.1 Double Acting Plumbing

1. Attach 1/2 inch pressure ("P") and tank ("T") lines to the NORAC valve block.
2. The existing hoses that run to the boom tilt cylinders should be disconnected from the sprayer valve block and teed in to the NORAC valve block.
 - a) The "raise" lines from the side of the cylinders, which raise the booms, must be connected (in parallel) to the "B" ports of the NORAC block.
 - b) The "lower" lines from the side of the cylinders, which lower the booms, must be connected (in parallel) to the "A" ports of the NORAC block.

4.5.3.2 Single Acting Plumbing

1. Attach 1/2 inch pressure ("P") and tank ("T") lines to the NORAC valve block.
2. The existing hoses that run to the boom tilt cylinders should be disconnected from the sprayer valve block and teed in to the NORAC valve block.
 - c) The "raise" lines from the side of the cylinders, which raise the booms, must be connected (in parallel) to the "B" ports of the NORAC block.
 - d) The "A" ports on the NORAC block are plugged. The "lower" lines of the cylinders can remain attached to the sprayer valve block.

4.6 ELECTRICAL INSTALLATION

1. Install the UC4+ Control Panel (E01) in the cab of the sprayer. Mount the panel where it will be clearly visible and within easy reach of the operator.

A good spot to mount the UC4+ control panel is on the right hand side of the cab to the Roll Over Protection Bar (ROP). Four pilot holes for the screws provided need to be drilled to facilitate the control panel mounting.

Another option is to purchase an adapter for the flexible panel mount that has a 3/8" NC threaded stud on the end to bolt through an existing mount. You can find these at your local outdoor store as a RAM mount part number RAM-B-236. (See <http://www.ram-mount.com/>)

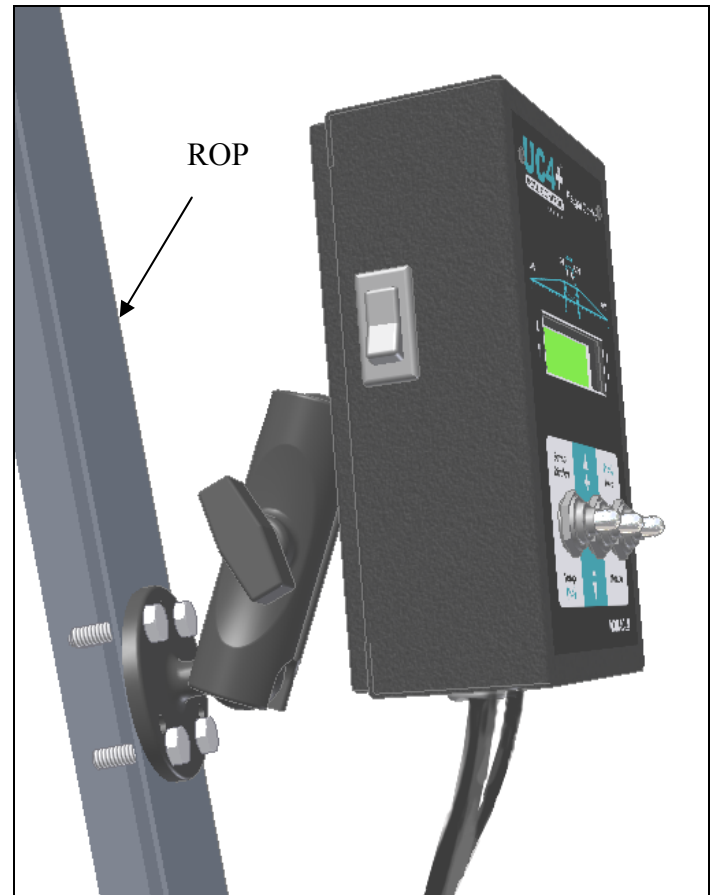

Figure 20 – Control Panel Mounting

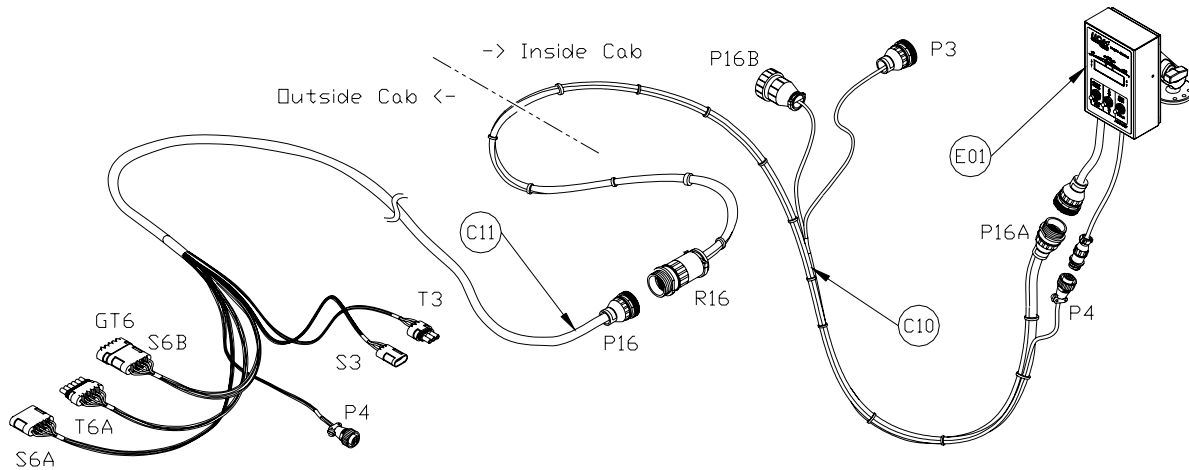

Figure 21 – Cable Configurations: C10 and C11

- ⚠ Read all the following installation instruction before connecting the NORAC Power Cable (C10).**
 - ⚠ Ensure the UC4 Control Panel’s power is OFF for the remaining installation (Bottom of switch pressed IN). Use caution when handling the 12 V power line of the sprayer wiring.**
2. Connect the UC4+ power cable (C10) to the UC4+ Control Panel in the sprayer cab. Ensure that both plugs (P16A and P4) are connected to the receptacles of the panel (Figure 21).
 3. The 3-pin AMP plug (P3) on C10 is connected to an auxiliary 12 V power connection in the cab.
 4. Route the receptacle end (R16) of C10 out of the cab.
 5. Connect the 16-pin AMP plug (P16) of the valve extension cable (C11) to the free end (R16) of C10 on the outside of the cab (Figure 21).
 6. Route C11 to the rear of the sprayer, in the vicinity of the valve block.

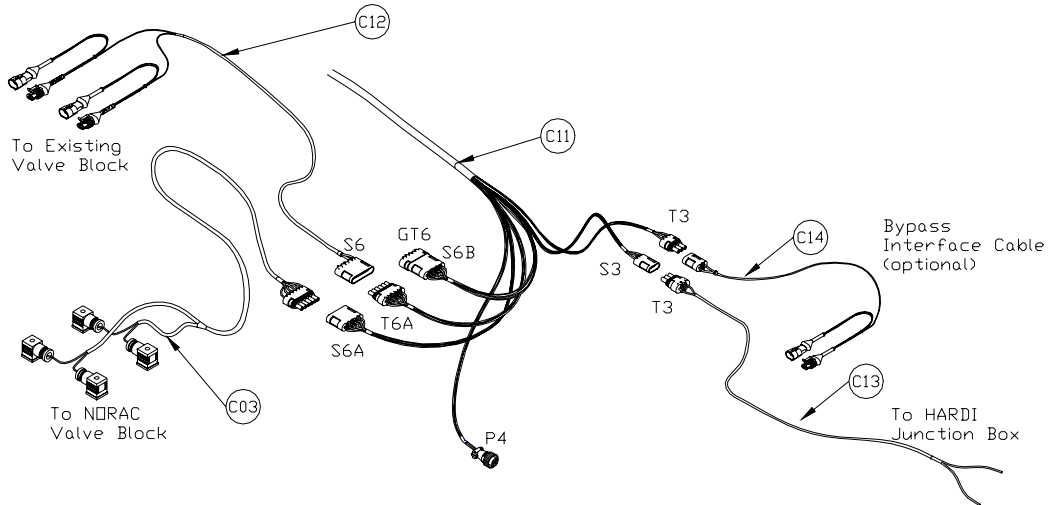

Figure 22 – Cable Configurations: C11, C12, C13 and C03

7. Connect the 6-pin shroud (S6) on the interface cable (C12) to the mating connector (T6A) on C11 (Figure 22).
8. Route C12 to the Hardi main lift valve block.
9. Insert 2 sets of tees between the matching Hardi main lift valve connections in accordance to the labels on wires.
10. Connect the 3-pin tower (T3) on the roll pigtail cable (C13) to the mating connector (S3) on C11.
11. Connect the wires labeled “CW” and “CCW” on C13 to the Hardi left and right tilt cartridge valve, respectively.
12. If your sprayer is equipped with a bypass valve, connect the 3-pin shroud on C14 to the mating connector (T3) on C11. Insert the tee on C14 between the connector on the bypass valve.
13. Connect the 6-pin tower on the valve cable (C03) onto the mating connector (S6A) on C11.

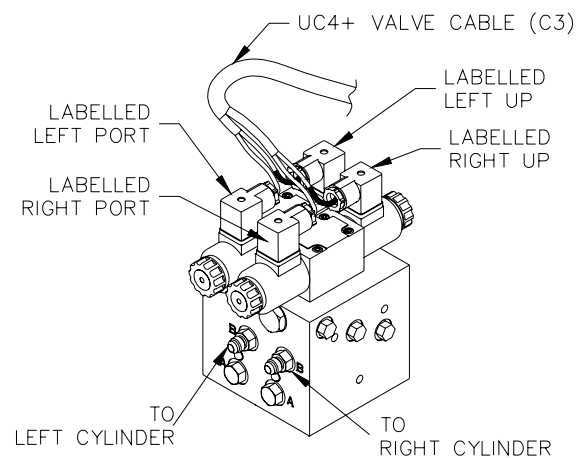

Figure 23 – Valve Cable Connections

14. As shown in Figure 23, the connectors on C03 are marked **RIGHT UP**, **LEFT UP**, **RIGHT PORT** and **LEFT PORT**. Cables labeled with **PORT** go on the side as the hydraulic hoses. Fasten with the included rubber seals and screws.

! Cable C14 is an optional cable ordered separately for sprayers with a bypass valve.

15. Connect the CAN Node cable (**C02B**) to the 4-pin AMP plug on **C11** (**Figure 24**).
16. Route the CAN Node cable (**C02B**) to the roll sensors which are installed in **Section 4.4**. Follow existing cables and/or hydraulic lines.
17. Connect the 4-pin AMP connectors to the roll sensors.
18. Connect the sensor branch cable (**C02**) to the 4-pin AMP plug on **C02B** (**Figure 24**).
19. Route the sensor branch cable (**C02**) to the wing and main sensors and connect to the sensors. Follow existing cables and/or hydraulic lines along the boom.
20. Cable-tie the installed cables every 12 inches.

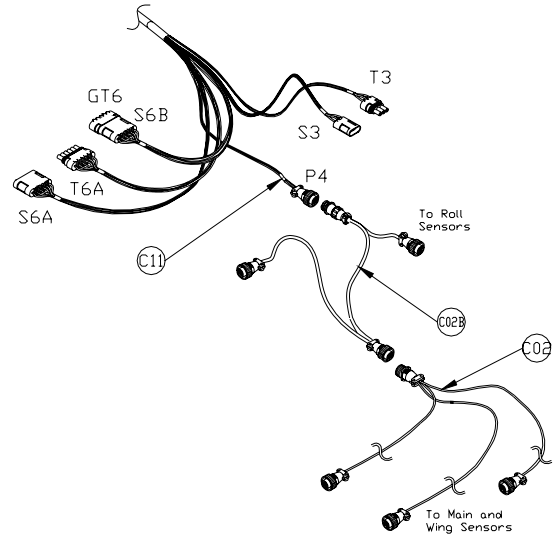

Figure 24 – Cable Configurations: C11, C02 and C02B

! IMPORTANT:

Provide enough slack in all cables to account for the movement of the main section, parallel lift, and FOLDING boom movement.

4.7 COMPLETING THE FACTORY INSTALLATION

1. Test the functionality of the original manufacturer's boom controls. The UC4+ control panel does not need to be powered up for the original switches to function.
2. Unfold the booms and raise/lower each boom and main section. Confirm that the cabling/hoses are agreeable to the entire range of motion. If one or more of these functions do not work, review the hydraulic and electrical portions of this manual to check for proper installation.
3. Connect the UC4+ control panel to the sprayer via the Generic power cable. This will require a power source (+12V).
4. Unfold the booms and level to 35 inches (nozzle height). At this point ensure the UC4+ sensors are reading from an adequate and uniform target, such as gravel or dirt, or concrete.
5. By using the “**Quick Install**” feature of the UC4+ control panel, the system may be configured in preparation for the End-User. However, a hydraulic “**RETUNE**” procedure will be required for optimal performance. This is required to tune the UC4+ hydraulic parameters to those of the End-User tractor hydraulic system.
6. To perform the “**Quick Install**” procedure, select the **HD3** sprayer type. However, rather than toggling “**YES**” to select the HD3 type, hold the toggle switch towards “**YES**” (for several seconds) until the word “**SENSOR**” appears on the UC4+ control panel screen.

7. The UC4+ control panel will then prompt the installer to “**EXIT CAB AND PUSH BOOM TIP DOWN TO GROUND**”. When exiting the cab and approaching the boom, avoid walking near the UC4+ sensors as this may result in measurement error.
8. At this point the UC4+ control panel should display the Main Operating Screen:

 (example)

indicating the system is ready for the second stage of installation. This will be carried by the end user (for the reasons as described above in **Step 5**).

5 ELECTRICAL REFERENCE – CABLE DRAWINGS

5.1 ITEM C02: 44668 – SENSOR BRANCH CABLE

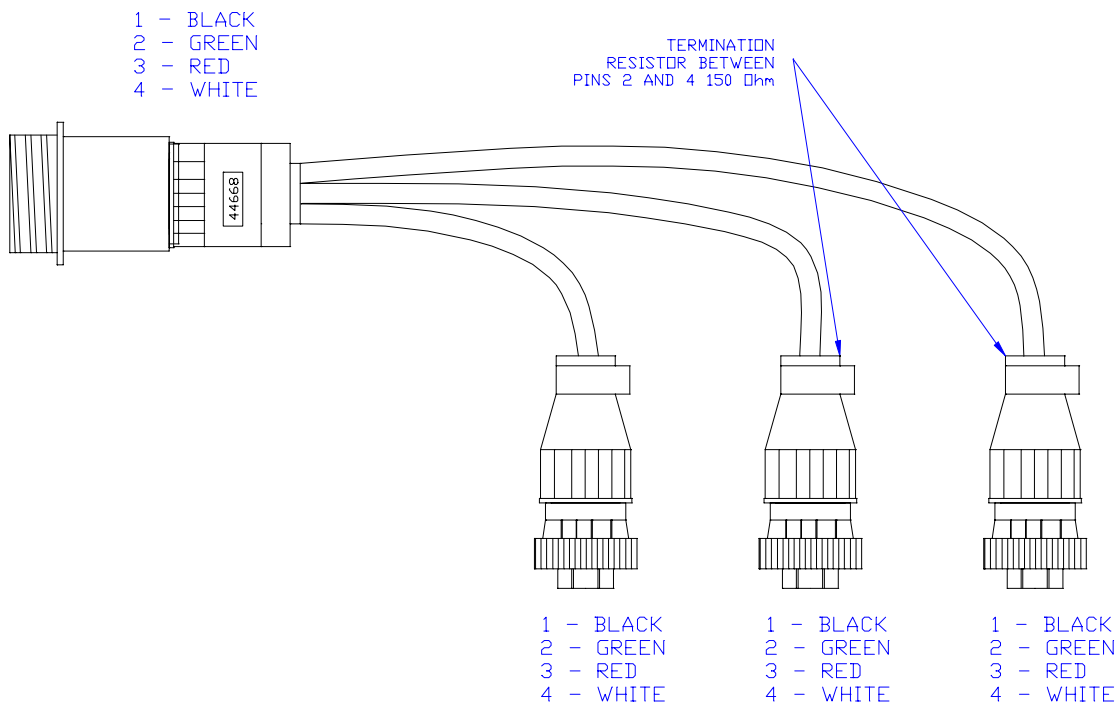

5.2 ITEM C02B: 44664 – CABLE UC4 CAN NODE DUAL

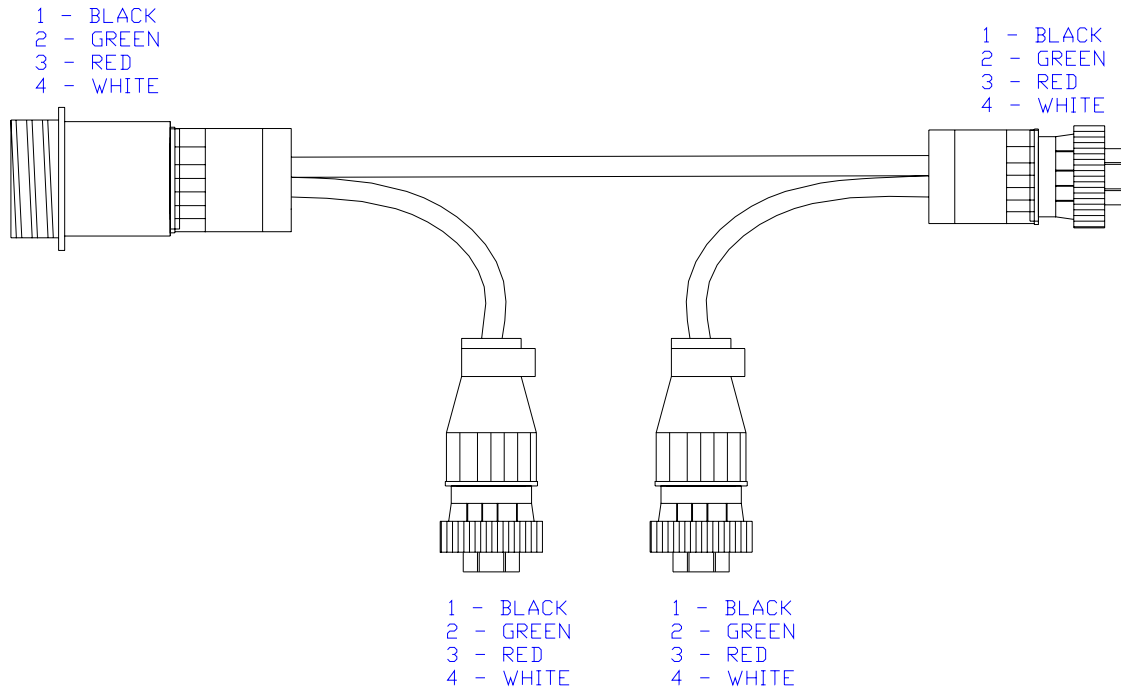

5.3 ITEM C03: 44656 – VALVE CABLE (VARIABLE RATE)

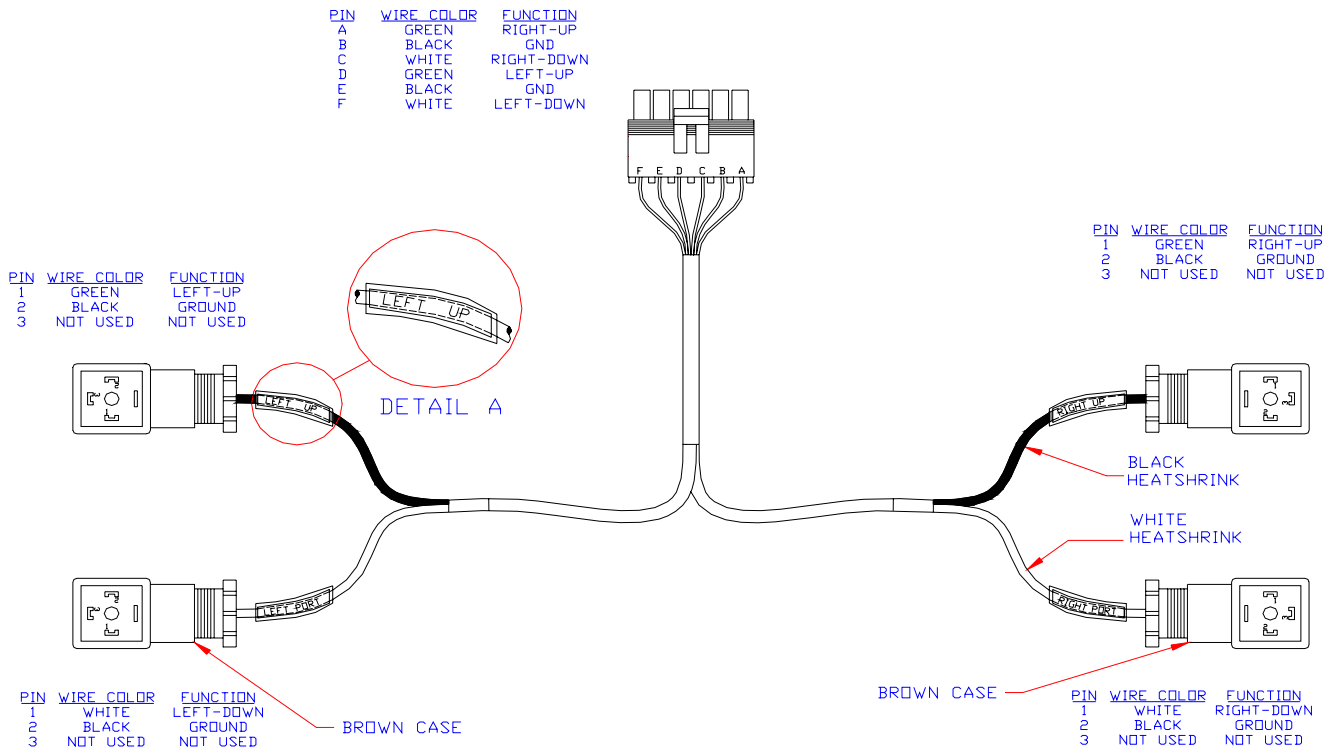

5.4 ITEM C10: 44650-35 – POWER GENERIC CABLE PULL-TYPE

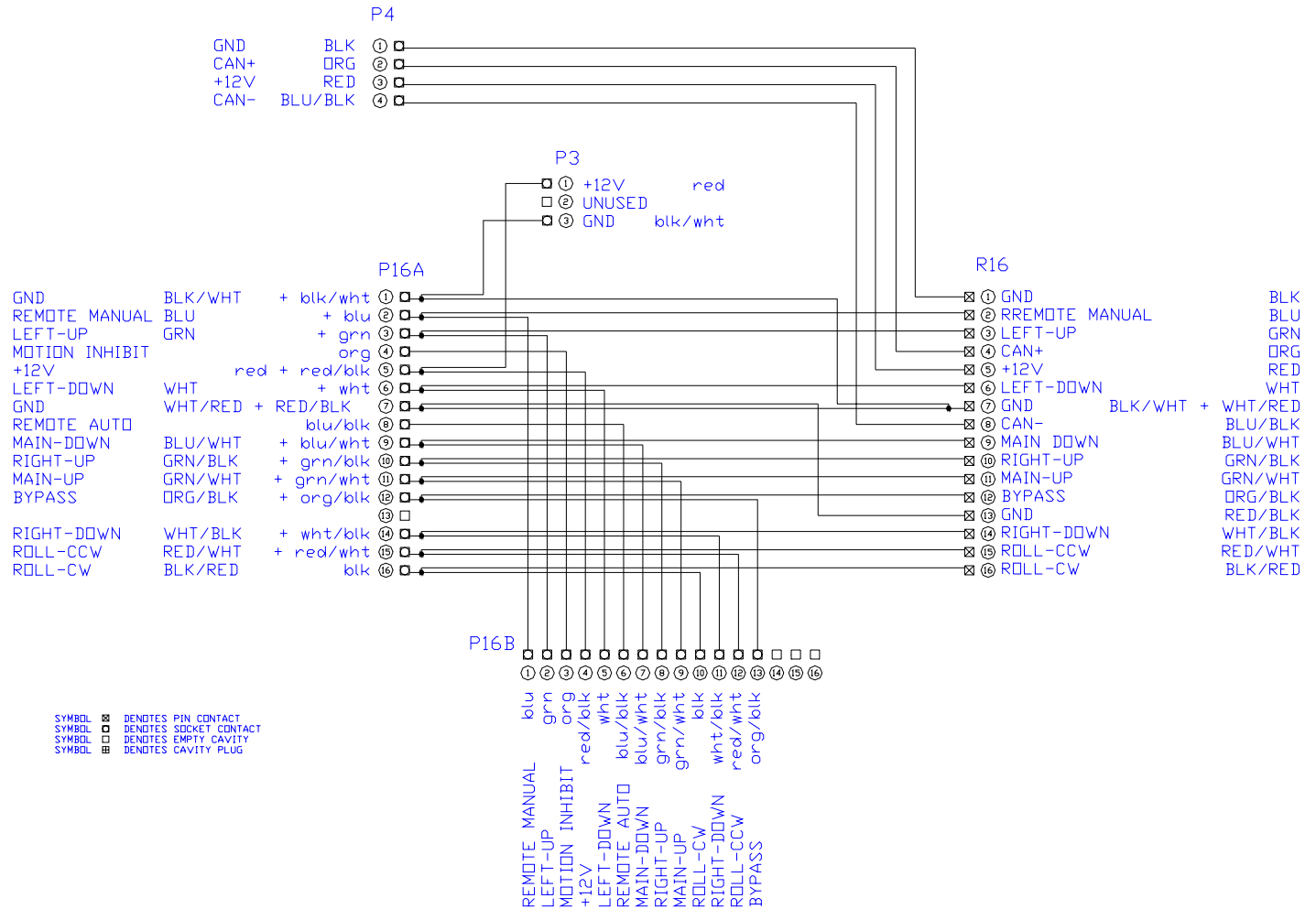
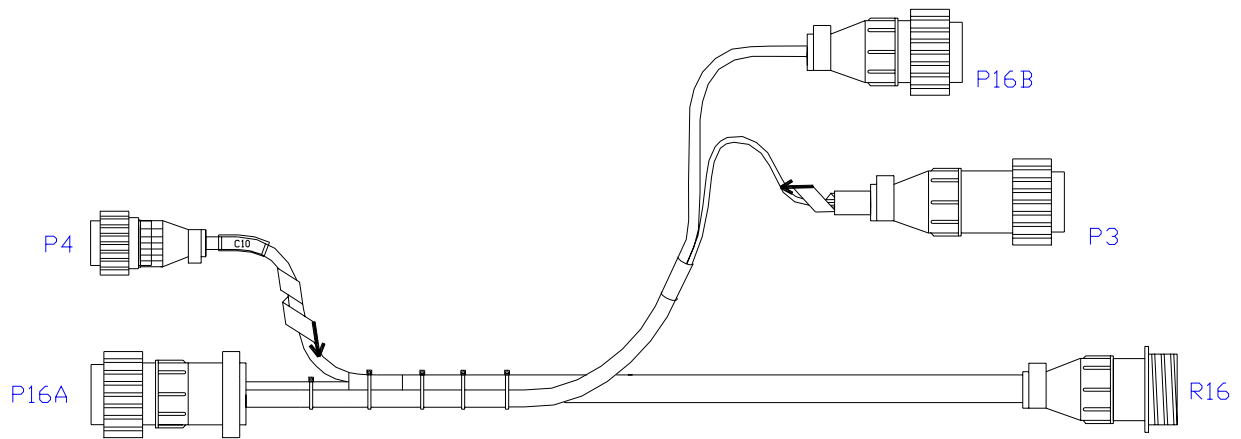

5.5 ITEM C11: 44651-03 – VALVE EXTENSION GENERIC CABLE

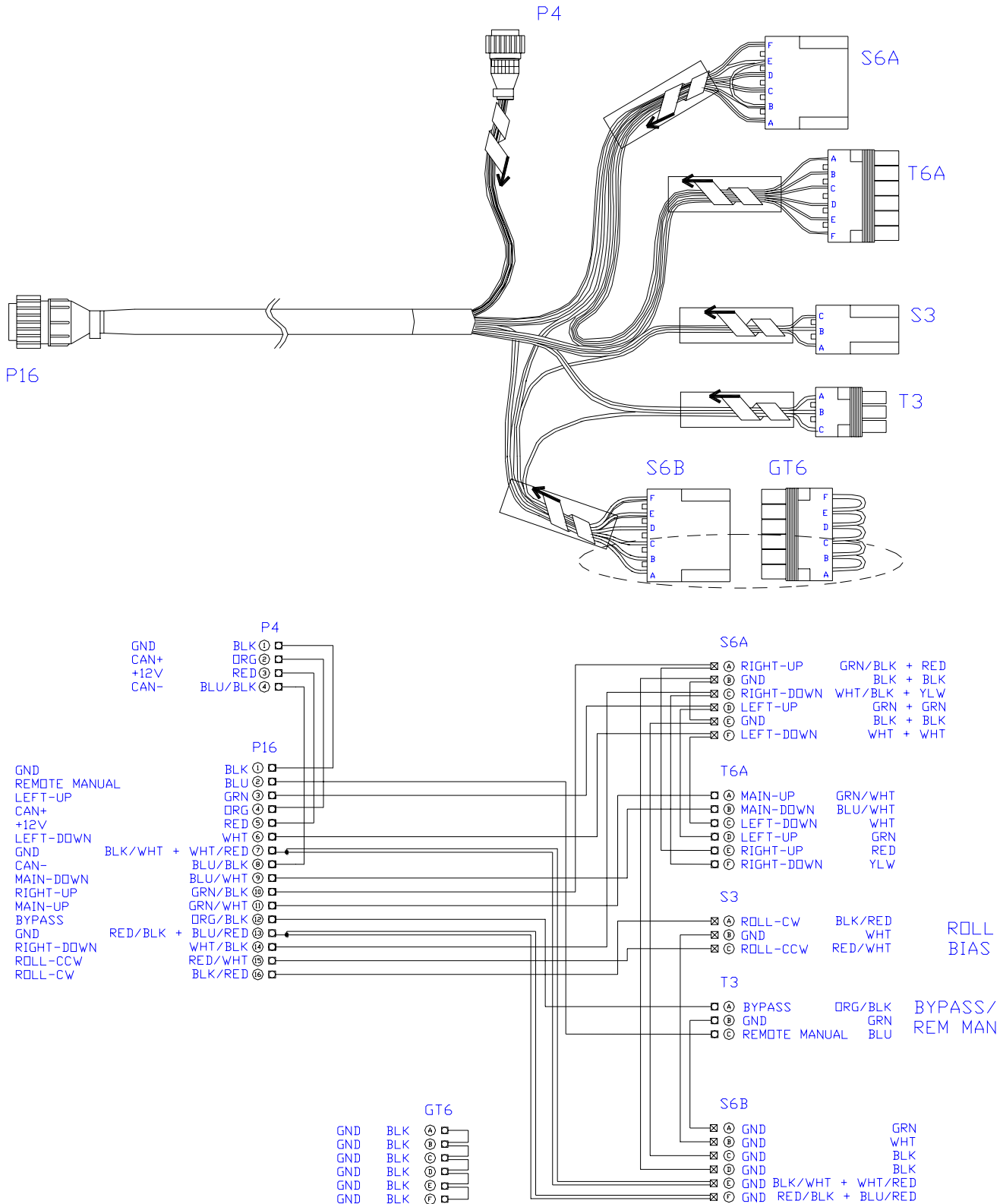

5.6 ITEM C12: 44658-42 – INTERFACE CABLE AMP ML ONLY

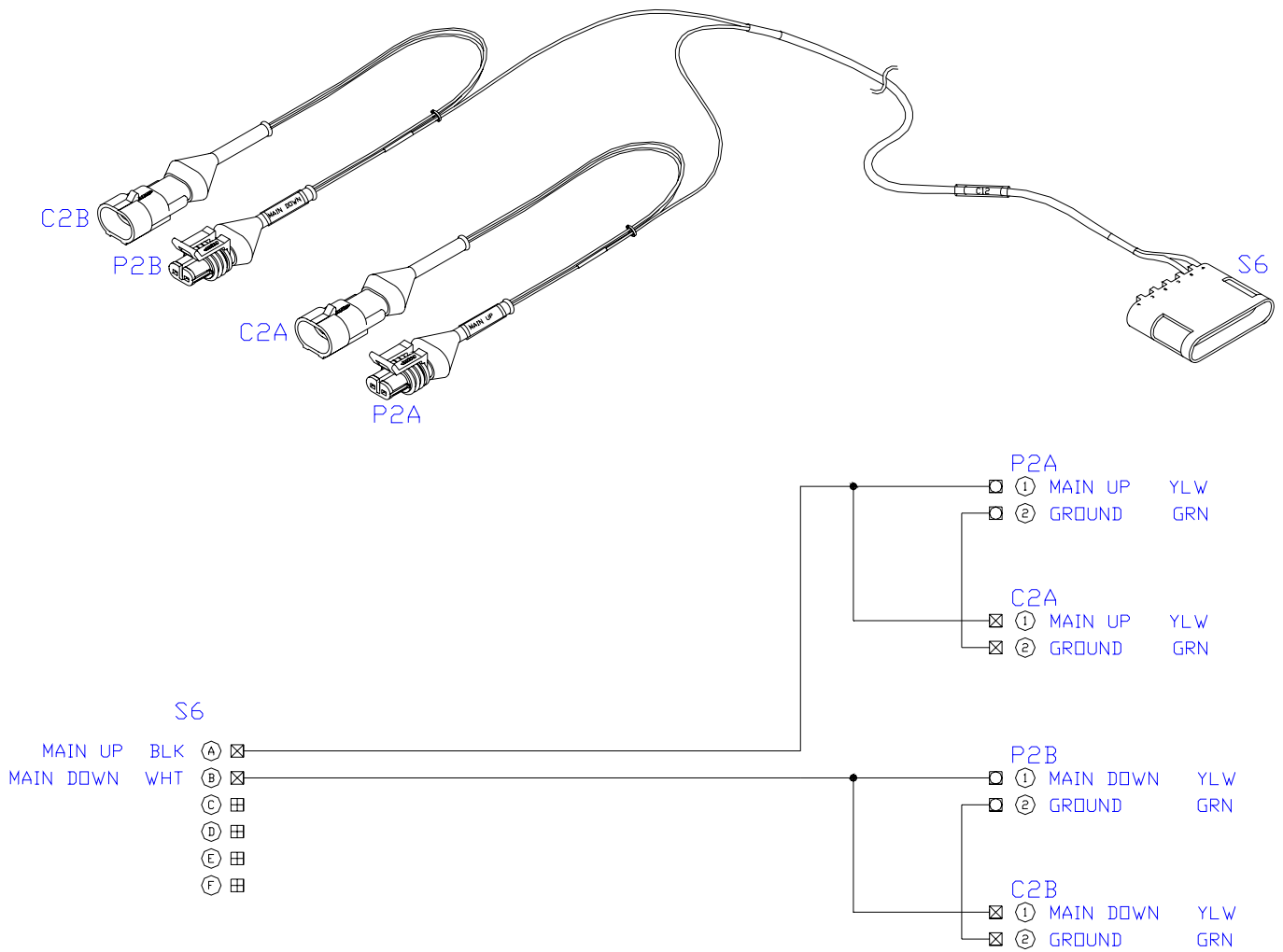

5.7 ITEM C13: 44658-49 – VALVE CABLE ROLL PIGTAIL

WIRE LABEL DESCRIPTION

BLK(N1A) - ROLL CW
 WHT(N1B) - ROLL CCW
 T3 - C5

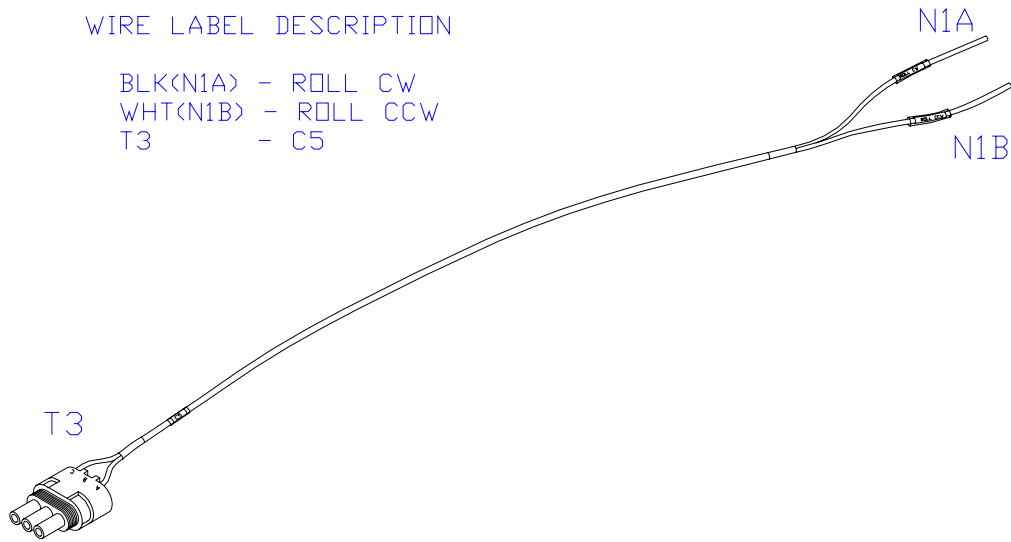

Wire Detail					
Terminal	Cable	Colour	Function	AWG	Terminal
T3.A - skt	Item 1	Black	Roll CW	16	N/C
T3.B - plg			N/A		
T3.C - skt		White	Roll CCW	16	N/C

5.8 ITEM C14: 44658-60 – BYPASS INTERFACE CABLE AMP (OPTIONAL CABLE)

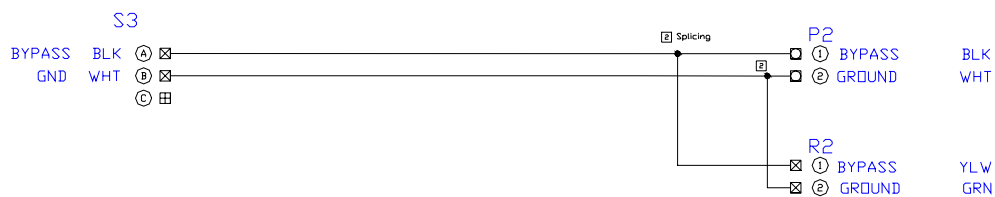
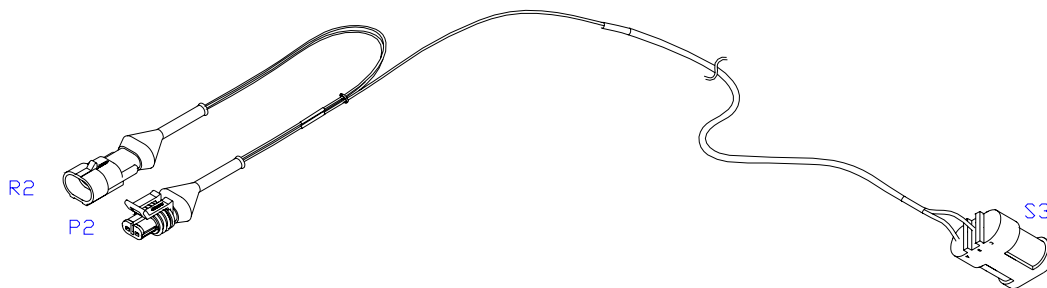

www.norac.ca

Canada

NORAC Systems International Inc.

CALL TOLL FREE: 1-800-667-3921
(306)664-6711

SHIPPING ADDRESS:

3702 Kinnear Place

Saskatoon, SK

S7P 0A6

United States

Norac, Inc.

CALL TOLL FREE: 1-866-306-6722
(763)786-3080

SHIPPING ADDRESS:

1290 Osborne Rd NE, Suite F

Fridley, MN

55432-2892