

NORAC

UC4+
ROLL CONTROL
Patented

Spray Height Controller



Operators Manual

Version 6 - 2008

Improving the competitiveness of Industry and
Agriculture through Precision Measurement

Printed in Canada

Copyright ©2008 NORAC Systems International Inc.

Reorder P/N: 446BC+MAN6+1 Revision A

NOTICE

NORAC Systems International Inc. reserves the right to improve products and their specifications without notice and without the requirement to update products sold previously. Every effort has been made to ensure the accuracy of the information contained in this manual. The technical information in this manual was reviewed at the time of approval for publication.

TABLE OF CONTENTS

1	INTRODUCTION	1
2	OPERATOR SAFETY	2
3	GENERAL SYSTEM DESCRIPTION	3
3.1	SOFTWARE.....	3
3.2	SENSORS.....	4
3.3	CABLES.....	6
3.4	CONTROL PANEL.....	6
4	SYSTEM OPERATION	7
4.1	POWER UP SEQUENCE.....	7
4.2	TYPICAL OPERATION.....	8
5	UNDERSTANDING YOUR UC4+ SYSTEM	13
5.1	UNDERSTANDING PERFORMANCE ISSUES.....	13
5.2	UNDERSTANDING CROP MODE AND SOIL MODE.....	16
6	SYSTEM SETUP	18
6.1	AUTOMATIC SYSTEM SETUP.....	18
6.2	RETUNE.....	26
6.3	MANUAL SYSTEM SETUP.....	27
6.4	QUICK INSTALL.....	35
7	MAINTENANCE	36
8	TROUBLESHOOTING	37
8.1	GENERAL OPERATION.....	37
8.2	SENSOR RELATED ISSUES.....	40
8.3	HYDRAULIC RELATED ISSUES.....	44
8.4	BOOM INSTABILITY AND MAIN LIFT.....	48
9	SYSTEM MESSAGES	49
9.1	SETUP MESSAGES.....	49
9.2	OPERATIONAL MESSAGES.....	51
10	STATEMENT OF LIMITED WARRANTY	53
11	SPRAYER TYPES	54
12	MENU STRUCTURE	55

1 INTRODUCTION

Congratulations on your purchase of the NORAC UC4+ Spray Height Control System. The system is manufactured with top quality components and is engineered using the latest technology to provide operating features and reliability unmatched for years to come.

When properly used, the UC4+ Spray Height Control system can provide protection from sprayer boom damage, improve sprayer efficiency, and ensure chemicals are applied correctly.

This manual is intended to be used in conjunction with the:

- **UC4+ Quick Guide**
- **UC4+ Installation Manual**

The manual provides a general description of the spray height control system, a section regarding system operation, and discussion related to understanding performance issues. Also provided are instructions for the use of the control panel, information regarding system setup, regular maintenance and troubleshooting.

Please take the time to read the complete manual before attempting to use the system. Although the UC4+ Spray Height Control system has been designed for easy set up and use, a thorough understanding of the information provided will ensure that you receive the maximum benefit from the system.

If you have any questions or comments regarding the operation of the UC4+ Spray Height Control system, please contact NORAC at any of the numbers below. If you require service, phone us or visit our web site for the location of the NORAC Service center nearest to you.

Phone: 1-800-667-3921 in Canada (Toll Free)
1-866-306-6722 in the United States (Toll Free)
0-800-404-8389 in the United Kingdom (Toll Free)
1-306-664-6711 all other regions

E-mail: service@norac.ca

Web Site: www.norac.ca

2 OPERATOR SAFETY

DANGER

 Always ensure that the UC4+ Spray Height Control system is powered down or in **MANUAL** mode:

- Before leaving the operator's seat
- While the machine is not moving
- When transporting the machine

 Under no circumstances should any service work be performed on the machinery while the UC4+ Spray Height Control system is in the **AUTOMATIC** mode.

 Before working on any part of the booms:

- Set the UC4+ System to **MANUAL** mode
- Turn the sprayer engine off

 Do not operate this system before:

- Reading and understanding the Operators Manual
- Thoroughly understanding your machine operation

 The UC4+ Spray Height Control system will greatly improve your spraying height accuracy and protect the boom against damage in a wide variety of field conditions. However, under some circumstances performance may be limited. The OPERATOR of the sprayer must remain **ALERT** at all times and override the automatic control when necessary. Refer to the warranty statement in Section 10 for more details.

3 GENERAL SYSTEM DESCRIPTION

Figure 1 shows the general layout of the UC4+ Boom Height Control system. The function of each of the major system components is described in this section.

NOTE: Some kits may not include all of the components shown.

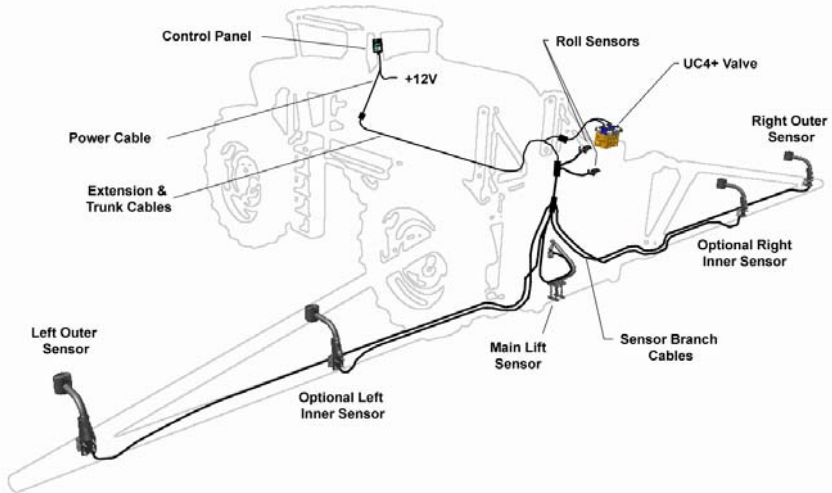

Figure 1 - System Components and General Location

For more information on each component, please refer to the UC4+ Installation Manual and UC4+ Quick Guide.

3.1 SOFTWARE

The information in this manual applies to systems with **Version 6** UC4+ control panel software. When the panel is turned on, the software version and revision will be displayed for a few seconds as described in **Section 4.1**. If your control panel does not display a version when it is turned on, your software is Version 1 (all revisions).

All UC4+ control panels can have their software upgraded for a nominal fee. It is recommended that all panels with earlier software be updated to the current software version. Contact your local dealer or NORAC for more information.

3.2 SENSORS

Three sensors are provided with your UC4+ boom control kit (with the exception of certain kits). The sensors use an ultrasonic signal to measure the distance to the ground, or the top of the crop. Three sensors are required to provide good overall height management of the boom. Two sensors are mounted on the outer sections of each wing (**Figure 2**). These sensors maintain each wing at the set target height independently.

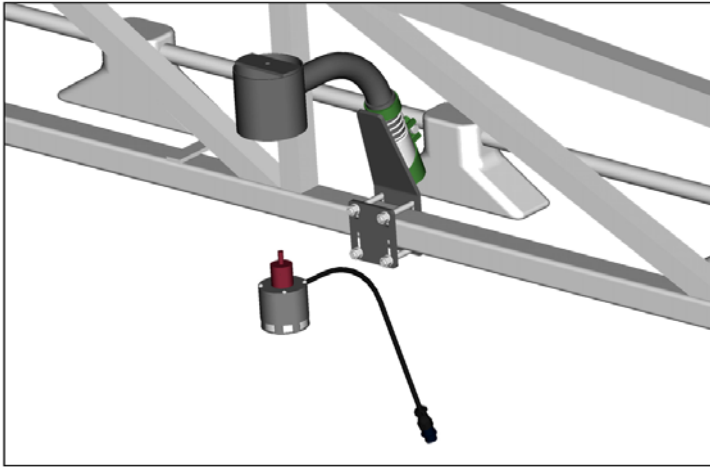

Figure 2 – UC4+ Sensor and Mounting Bracket

The third sensor (if applicable) is mounted on the main (center) boom section. The main boom sensor is useful for setting your initial spray height when you begin spraying in a field.

It is true that the main boom height will not change much, in consistent soil conditions, since both ends of the main boom follow the height of the power unit. However, it is extremely difficult to judge the boom's actual height accurately from the cab. It is also very difficult for the operator to see the main section nozzles. It is common for operators to be in error from 20 to 30 cm (8 to 12 inches) or more (How often does the operator check nozzle height with a tape measure?). The UC4+ control panel will give you an actual height reading in the cab, and allow active control to the desired height.

Another good reason for the main boom sensor is that soil conditions change along with the weight of the machine. As the sprayer tank fluid level changes throughout the day and soil conditions vary, the main boom height will change because of the amount the tires sink into the soil.

Special attention must be taken into consideration when mounting the main boom sensor, as explained in the UC4+ Installation Manual for your sprayer.

NORAC ultrasonic sensors are designed to work best in the brackets provided (**Figure 2**). If you decide to use a different style of sensor mount, you may limit the performance of the sensor and/or void your warranty. Further, it is important to follow the guidelines in the UC4+ Installation Manual for mounting the sensors. The sensors should be at least 25 cm (9 inches) above and 25 cm (9 inches) in front of the spray nozzles.

For large boom or severe terrain applications, an additional sensor may be mounted near the midpoint of each boom to obtain an average height reading. The average height reading will provide improved height control over the length of the boom, and protect the boom in severe terrain conditions (**Figure 3**).

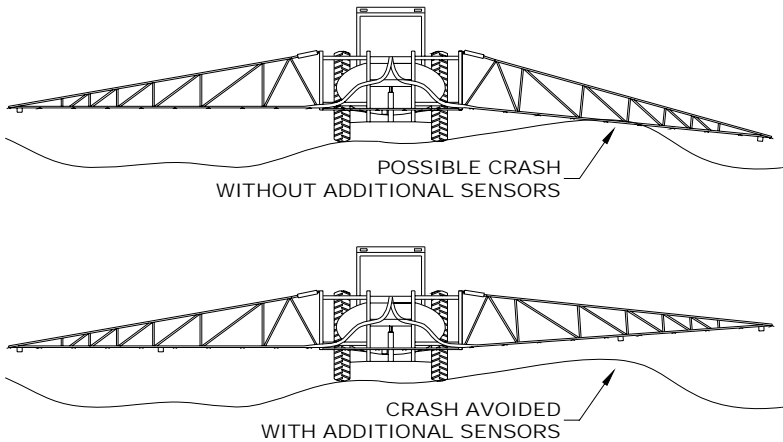

Figure 3 – Severe Terrain – Additional Sensors Required

On sprayer models with main frame roll capability (**Figure 4**), the main boom sensor can also be used to adjust the roll angle of the entire boom. Alternatively, roll sensors can also be used to adjust the main roll angle of the entire boom. Addition of this sensor to the UC4+ Spray Height Control system can greatly improve the speed and stability of the automatic control actions. Contact NORAC for more information on the availability of roll control for your sprayer model.

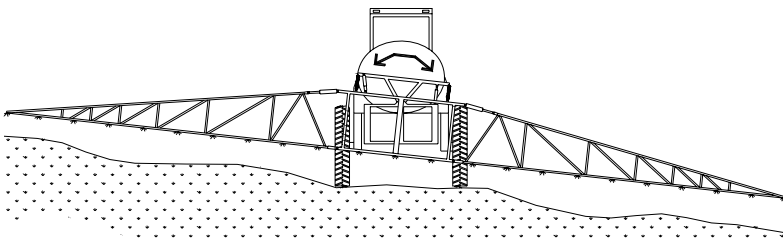

Figure 4 – Roll Control of the Main Frame

3.3 CABLES

The power cable supplies 12 volt D.C. negative ground power to the control panel and sensors. The system will function properly with a supply between 12 and 28 volts and may draw up to 10 amperes during normal operation.

The UC4+ control panel contains intelligent valve drive circuitry that helps to protect the sprayer's system against short circuits and other wiring problems. However, it is still recommended to connect the UC4+ power cable to a fused supply, that turns on and off with the ignition key of the sprayer/tractor. For more information on cables, please see the **UC4+ Installation Manual**

3.4 CONTROL PANEL

The UC4+ control panel (**Figure 5**) is the main component of the UC4+ Spray Height Control system. The control panel uses the readings from the ultrasonic sensors to control solenoid operated valves that in turn adjust the boom height. The control panel will:

- (1) indicate when the system is in **AUTOMATIC** or **MANUAL** mode,
- (2) indicate any hydraulic action which is underway
- (3) accept input to adjust all control system settings.

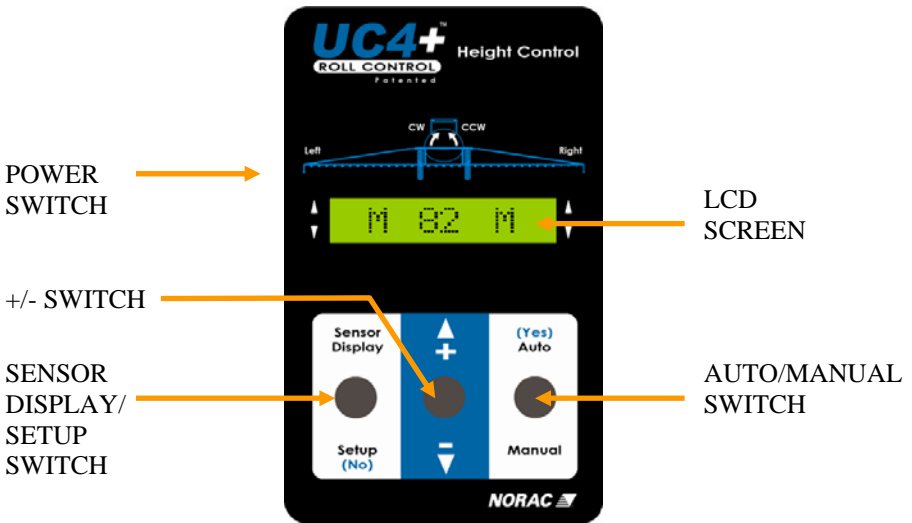

Figure 5 – UC4+ Control Panel

4 SYSTEM OPERATION

This section outlines the UC4+ Spray Height Control system's features and controls during field operation. Before you can operate your UC4+ Spray Height Control system in **AUTO** mode, it needs to be configured either automatically or manually. If your control panel shows the power up sequence below and will allow **AUTO** mode, it has been configured. If your panel shows different messages after being powered up or will not allow **AUTO** mode, it will attempt to begin or resume Automatic System Setup. Refer to **Section 6** for System Setup instructions.

4.1 POWER UP SEQUENCE

The LCD screen messages shown below are displayed temporarily when power is turned on to the UC4+ control panel. The system will always power up in manual mode. Once the Normal Operating Screen is shown the system is ready to use.

Table 1 – Power Up Screens

LCD Display	Description
UC4 +	UC4+ Control Panel
V. 6C	Version 6 software
Type AN2	Sprayer Type: AN2. See Sprayer Types on page 54 – for a list of types.
METRIC	The panel is setup to display height in centimeters. This can be changed to display inches.
* Nodes	The control panel is looking for connected sensors.
3 Height	Three height sensors are connected.
Allocate	The control panel is preparing to set up each sensor.
Setup LO	The control panel is setting up the Left outer (LO) sensor, followed by the other sensors (LI, RO, RI, MR, ML).
Ready	The control panel is ready to begin operation
M 75 M	The Normal Operating Screen. This screen is shown until input is received from the operator. (Sec 4.2.1)

4.2 TYPICAL OPERATION

4.2.1 Normal Operating Screen

The Normal Operating Screen provides information pertaining to the height and mode of both booms. **Figure 6** shows a typical Normal Operating Screen.

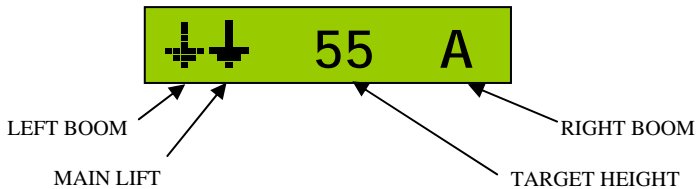

Figure 6 – Normal Operating Screen

When a boom is in **AUTO** mode, indicated by an "A" in the control mode portion of the screen, the UC4+ panel shows the target boom height. In **MANUAL** mode, indicated by an "M" in the control mode portion of the screen, the UC4+ control panel shows the average boom height reading.

In both **AUTO** and **MANUAL** modes, the screen will also show arrows to indicate that the boom is being commanded to move. **Table 2** explains some examples of typical Normal Operating Screens.

Table 2 – Examples of Normal Operating Screens

LCD Display	Description
A 89 A	In AUTO mode, target average height is 89 cm (or inches if selected)
↑A 89 A	Left side taking corrective action upwards
A 89 A↓	Right side taking corrective action downwards
↓ 89 A	Main lift is taking corrective action downwards
A 89 ↻	Main roll section is taking action in the clockwise direction
M 89 A	Left boom in MANUAL mode Right boom in AUTO mode with actual height of 89
M 89 M↓	Booms are in MANUAL mode with actual height of 89 Operator is manually lowering the right boom
↓↑ 89 A↓	Left and right booms are in AUTO and lowering Main boom is in AUTO and lifting

4.2.2 Main Menu Overview

Table 3 – Main Menu Structure

Navigating past the end of the menu will return the control panel to the Normal Operating Screen	
More ?	Toggle the "AUTO (YES)" switch to edit or view more sensor settings.
88 0 67	Displays diagnostics information used by technical staff.
↔ 56 ↔	Displays the current main lift height, in the selected units.
→ 55 55	Displays the current right boom heights, in the selected units, from left to right.
55 55 ←	Displays the current left boom heights, in the selected units, from left to right.

M 55 M	SENSOR DISPLAY Menu ↑ SENSOR DISPLAY / SETUP (NO) Switch ↓ SETUP Menu	<p>The Normal Operating Screen is usually displayed. If no switch is toggled for 30 seconds, the LCD will revert to this screen. From any menu prompt, if you toggle and hold the "SETUP (NO)" switch for two seconds, the control panel will return to this screen.</p>

Sensi 5	Displays the current control sensitivity setting. A higher number results in a quicker response. Range is from 1 to 10.
Soil ON	Use the " +/- " switch to set the sensor target to SOIL or CROP mode.
ReTune?	The ReTune will optimize your system for the best performance possible. This will take from one to three minutes. (<i>Section 6.2</i>)
More ?	Toggle the "AUTO (YES) " switch to edit or view more control settings.

Navigating past the end of the menu will return the control panel to the Normal Operating Screen

4.2.3 Using the Toggle Switches

All functions on the UC4+ control panel are activated using its three toggle switches. To access either the **SENSOR DISPLAY** or **SETUP** menus, make sure you are at the Normal Operating Screen. To adjust the setting of individual menu items, use the " +/- " switch while the item is displayed.

- New settings take effect once the Normal Operating Screen is displayed

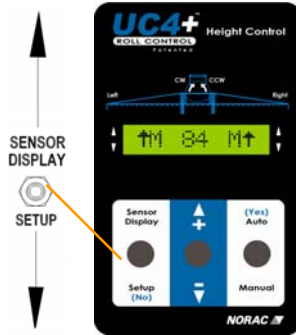

Figure 7 – Normal Operating Screen

Menu items will time out and return to the Normal Operating Screen after 30 seconds. If you wish to return to the Normal Operating Screen sooner, toggle and hold the "**SETUP (NO)**" switch for two seconds. Any new settings will take effect once the Normal Operating Screen is displayed.

If you wish to lock the sensor height readings on the screen indefinitely, toggle the " **+** " switch once while viewing the desired sensors.

4.2.4 Changing to AUTOMATIC or MANUAL Mode

You can change between **MANUAL** and **AUTO** with the "**AUTO (YES) / MANUAL**" toggle switch. Ensure you are at the Normal Operating Screen.

When the UC4+ is in **MANUAL** mode, the boom may be controlled as usual with the boom control switches on the sprayer's multifunction handgrip.

When the UC4+ is in **AUTO** mode, operating the sprayer's left or right boom control switches will immediately cause that boom to revert to **MANUAL** mode. The sprayer (joystick) switches will override automatic boom height control on either the left or right side. The "**AUTO (YES)**" switch must be activated to return that boom to **AUTO** mode.

The sprayer's main lift control (main up or main down) switches provide a target height adjustment feature (**Section 4.2.5**). If you press and hold either the main up or the main down switches for more than two seconds, the UC4+ control panel will switch ALL booms (left, right, main, and roll) to **MANUAL** mode. This feature provides a convenient method of switching to **MANUAL** mode when folding the sprayer for transport.

4.2.5 Adjusting the Target Height (Setpoint)

Adjust the target height setting with the "+/-" switch while in **AUTO** mode. The smallest target height setting allowed is called the minimum height override. The default minimum height settings are programmed before shipped from the factory.

NOTE: The minimum height settings are adjustable. – If you wish to adjust them, please contact NORAC for details.

You can also adjust your main boom target height by pressing the sprayer's main lift control switches. Each press of the up switch will increase the target height by one unit. Each press of the down switch will decrease the target height by one unit.

4.2.6 Viewing the Actual Boom Height

Toggle the "**SENSOR DISPLAY**" switch to view the actual boom heights. This height is from the nozzles to the ground. This menu will show you the left, main (center), and right boom heights. Toggle the "**SENSOR DISPLAY**" switch again to view additional sensors if they are installed. You can view the height menus in both **AUTO** and **MANUAL** modes.

4.2.7 Changing the Sensitivity of the System

The Sensitivity (**Sensi**) setting (**Section 5.1.1**) can be adjusted in both **MANUAL** and **AUTO** modes. Toggle the "**SETUP (NO)**" switch to view the current **Sensi** setting. While viewing this menu, toggle the "**+/-**" switch to adjust the value.

A lower number will reduce the system sensitivity and improve stability. Increasing the number will speed up the response.

Five is the normal setting. At the start of operation, before the sprayer is warmed up, a lower **Sensi** setting may be required for stable control. As the sprayer warms up, increase the **Sensi** setting up until the performance reaches an optimum level.

4.2.8 Changing Between SOIL and CROP Mode

The **SOIL** or **CROP** mode (**Section 5.2**) setting can be adjusted in both **MANUAL** and **AUTO** modes. Toggle the "**SETUP (NO)**" switch twice to view the current setting. While viewing this menu, use the "**+/-**" switch to change between **SOIL** and **CROP** mode.

4.2.9 Changing between Inches and Centimeters

The panel can be changed to display either centimeters or inches. Toggle the "**SENSOR DISPLAY**" switch until the LCD screen says "**MORE ?**". Toggle the "**YES**" switch once and then toggle the "**SENSOR DISPLAY**" switch until the LCD screen displays "**OTHER ?**". Toggle the "**YES**" button and then use the "**+/-**" switch to change between **CM** and **INCHES** mode.

5 UNDERSTANDING YOUR UC4+ SYSTEM

5.1 UNDERSTANDING PERFORMANCE ISSUES

Your UC4+ Spray Height Controller will work well in most situations. However, as with any equipment, it is important that the operator remains alert at all times. There may be some field and terrain situations where performance is diminished. In these situations the operator must resume height control of the booms manually. A discussion of performance issues is given below to help clarify these situations.

5.1.1 Sensitivity (Sensi) Setting

The UC4+ Spray Height Control system is configured to work well in most conditions, with warm hydraulic oil, at a sensitivity (**Sensi**) setting of five. When you first begin operation at the start of a day, it may be necessary to operate at a lower sensitivity until the oil has reached normal temperature. Keep increasing the **Sensi** setting until the performance is optimized.

Different types of terrain may require different **Sensi** settings. The **Sensi** setting controls more than just response time. It also determines how accurately the UC4+ Spray Height Control system will try to correct for height errors. The higher the sensitivity the higher the accuracy. At low sensitivity a few cm/inches of error will be tolerated. At high sensitivity, virtually no error will be tolerated. Therefore, the system will be much more active at high sensitivity than at low sensitivity.

NOTE: Field conditions and operator preferences determine the appropriate Sensi setting. On some sprayer models, it may be difficult to reach an optimum level of sensitivity while maintaining good boom stability. This could be an indication that the boom is mechanically under-damped for control purposes. Additional shock absorbers/dampers can dramatically improve automatic control performance. Some UC4+ kits come complete with additional damper kits. Other sprayer models have damper kits available from the sprayer manufacturer or from NORAC as optional equipment. Contact NORAC or your sprayer dealer for more assistance.

5.1.2 Boom Reaction Time

There are two key factors that determine how quickly your boom can react to changes in terrain. The first factor is the available hydraulic speed. The maximum hydraulic speed of your boom was designed by the sprayer manufacturer and is not improved or diminished with the addition of the UC4+ height control system.

The second factor is the mechanical design of the sprayer. The **Sensi** setting does affect the reaction time of your boom – the higher the number the quicker the response. However, how high you can run the **Sensi** setting is determined to a large extent by mechanical issues related to the boom and sprayer.

Important design issues include the style of main boom mount (for example, center pivot or nonparallel links), the amount of mechanical damping and spring centering on the main boom mount, and whether a main boom roll system is available on the sprayer. All of these factors together determine the maximum **Sensi** setting you can run on your UC4+ Spray Height Control system. This, in turn, will set the reaction time of the boom in a given situation.

The UC4+ electronics are rarely the limiting factor in determining overall automatic height control performance.

5.1.3 UC4+ over Ditches, Waterways and Outside Rounds

Many situations exist where one sensor may be reading over terrain that does not accurately reflect the situation for the rest of the boom. For example, if you are spraying along a waterway, it may be necessary to run the outer boom sensor out into the waterway itself. This situation is similar to the picture in **Figure 3**. In this example, the outer sensor will bring the boom lower than desired and may put the mid-point of the boom at risk. Outside rounds adjacent to very weedy areas or tall thick grass are examples of the opposite situation.

In these situations the operator must remain alert and override **AUTO** mode when necessary. Addition of the optional severe terrain (inner) sensors will greatly improve performance in these situations.

5.1.4 Driving Through Ditches and Over Terraces

Changes in terrain that include driving over terraces or through ditches are special performance cases. This type of terrain can cause the sprayer or spray cart to pitch and roll significantly. Sprayer operation at speeds of 15-30 km/hr (10-20 mph) in severe terrain may result in rapid changes in boom tip height. In these situations, typical sprayer hydraulic systems are not capable of tip speeds high enough to correct for the induced error.

There are two solutions to this problem. The first solution is for the operator to recognize these situations before they occur and manually raise the boom section(s) to a safe height. To return to **AUTO** mode, use the "**AUTO (YES)**" switch.

The second solution is to add a roll control system to your sprayer (if one is available). This type of system will compensate for the sprayer roll in this situation and also add stability to your boom in normal operating conditions.

5.1.5 Sensing Further Ahead of the Boom

Installing the sensor farther ahead of the boom is not an acceptable solution to any performance issues. The reason is that, as the sensor is moved further ahead, there will be an increasing height error at the nozzles. In other words, the sensor and nozzle are at two different points in space, thus introducing an error for all but the most level terrain. In severe terrain, this height error can bring the nozzles close to the ground as the sensor reads over the crest of a hill, or down into a ditch.

5.1.6 Sensor Capabilities

In order for the UC4+ Spray Height Control system to work at its maximum level of performance, the UC4+ sensors must be returning accurate height readings at the designed frequency. Under typical conditions, the sensors can provide accurate height readings from 9 inches to over 120 inches, and return many height readings in one second. The target in **SOIL** mode can be identified through stubble, young crops, row crops, and normal trash. The target in **CROP** mode can be identified over cereal grains, specialty crops, and row crops. See the next section for more information on **CROP** and **SOIL** mode guidelines

There are two main steps to ensure sensor performance. The first step is proper mounting. See **Section 3.2** on page 4 for more information on sensor mounting. The second step is to ensure that the protective foam covers on the sensors are kept clean, and that the ultrasonic transducer behind the foam does not become corroded or excessively dirty. Extra foam pieces are shipped with your kit. The transducer is a maintenance item and can be replaced at NORAC service locations. Transducers can last from three to ten years, depending on conditions. Refer to **Section 7** on page 36 and the UC4+ Quick Guide for more maintenance information.

If the mouth of the sensor becomes wet, it is normal for the sensor to return error messages until the transducer has dried off. This could include rain or excessive overspray. Material can build up on the transducer if the sensor is mounted too close to the spray nozzles. This is the reason that the sensor must be mounted at least (25 cm) 9 inches in front of the nozzles. It keeps the sensor housing out of the normal region of overspray.

In the sprayer boom application, the sensors ignore any target that is closer than 25 cm (9 inches) from the bottom of the sensor housing. This region is called the blanking range. Operating the sensor at heights near the blanking range is dangerous and will affect performance because height readings can be very intermittent. This is the reason that each sensor must be mounted at least 25cm (9 inches) above the spray nozzles.

5.2 UNDERSTANDING CROP MODE AND SOIL MODE

A unique feature of UC4+ sensors is their ability to operate in **CROP** mode. In this mode the sensor will track the first available sonic target. That is, when positioned over standing crop, the sensor will return the average height of the heads in a circular area below the sensor. In the same situation in **SOIL** mode, the sensor will track the last available sonic target. That is, signals from the heads, leaves, and trash will be ignored in favor of the ground.

It is important to note that the targets must be available and of sufficient strength for the sensor to "see" them. There may be some crop and terrain situations that do not work well for **CROP** mode or **SOIL** mode. In these situations the operator must resume height control of the booms manually.

In general, the addition of the severe terrain kit will improve performance in **CROP** mode. All of the situations discussed below are lessened by the addition of the extra sensors on the wings.

5.2.1 Areas of "No Crop" in CROP Mode

If, while operating in **CROP** mode, the sensor encounters an area where there is no crop, the system will behave as follows. The sensor will track the soil because only one target is available. The boom will lower as shown below. Areas like this may include missed areas during seeding, alkaline areas, and so on. When the problem area ends, it may not be possible for the sensor to see the crop again unless the operator raises the boom manually. The sensor may be closer than required 25 cm (9 inches) from heads of the crop, thus blanking out the desired target.

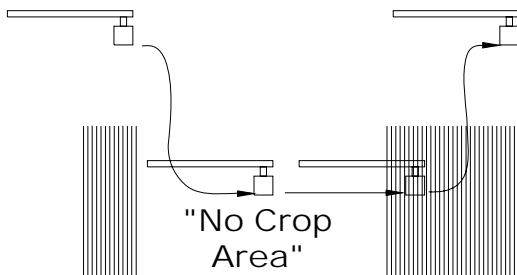

Figure 8 – Area of "No Crop" When Operating CROP Mode

5.2.2 Boom Stability in Crop

In general the top of the crop is a more inherently variable target than soil. To put it simply, given identical control settings, your height control would be more active when operating in **CROP** mode than in **SOIL** mode. To allow for this, many settings are customized automatically when you change modes on the UC4+ control panel. This is designed to provide a more stable response in **CROP** mode. The tradeoff is that the system will also be slightly slower to respond in **CROP** mode than in **SOIL** mode.

5.2.3 Thin Crop

The UC4+ ultrasonic sensors operate by bouncing sound waves off the desired target. A minimum signal level is required from the crop in order to use it for control purposes. This is no different than the fact that your radio must be at a certain minimum volume level before you can physically hear it. Different types of crop, and crops at different stages of development return varying levels of sound. The following are some general guidelines.

- Crops in growing stages are relatively good sonic targets.
- Bearded crops are relatively poor sonic targets.
- In row crops, the sensor must be positioned over the row to use the crop signal, or between the rows to use the ground signal.
- The desired target must cover roughly 60 percent of the area to be tracked consistently. That is, when looking at the ground, the heads should cover about 60 percent of the ground. Otherwise, you can use **SOIL** mode.
- If the sensor runs too close to the heads, they may not return enough signal to be seen, or they may be blanked out. The nozzles must be at least 55 cm (22 inches) from the crop. Slightly higher target height settings will work better in thin crop.

5.2.4 Main Boom Sensor in Wheel Track

The required location for the main boom sensor is determined by the UC4+ Installation Manual for your sprayer and by the options you have installed. Special attention is necessary when mounting the main boom sensor. Mounting the main boom sensor directly behind a sprayer tire may impair main lift control when operating in **CROP** mode. Height readings from crop that is flattened by the sprayer wheel do not provide an accurate measurement of canopy height, resulting in poor performance.

6 SYSTEM SETUP

Before the UC4+ boom height control system will function properly, some information about the sprayer and connected sensors is necessary. When the control panel is turned on for the first time, the UC4+ control panel guides the operator through the Automatic System Setup. This procedure is described in **Section 6.1**. Normally the UC4+ Spray Height Control system will automatically configure and calibrate itself to the sprayer. If this process does not produce the desired results, perform Manual System Setup described in **Section 6.3**. From time to time it may be necessary to **ReTune** the UC4+ electronics to your sprayer's hydraulics. This procedure is described in **Section 6.2**.

6.1 AUTOMATIC SYSTEM SETUP

The first time the UC4+ Spray Height Control system is powered up, it will guide you through the Automatic System Setup to customize the UC4+ settings to your sprayer. The entire procedure should take approximately two to seven minutes.

At any point during the setup procedure, you can exit by toggling the "**SETUP (NO)**" switch. However, if you exit without completing the System Setup, you may not be able to use the UC4+ in **AUTO** mode.

If you wish to restart/rerun this procedure after an initial setup has been completed, navigate to the "Install?" prompt in the **SETUP** menu and confirm the action with the "**AUTO (YES)**" switch.

NOTE: If you confirm the "Install?" menu prompt by accident, you can exit by toggling "SETUP (NO)" before confirming a sprayer type. No settings will be lost. However, if you confirm a sprayer type and the "Dfaltering" message (STEP 4 in Section 6.1.5) appears, all previous system settings will be lost. You may need to perform Automatic System Setup again.



WARNING!:

- **AT POINTS DURING THE SYSTEM SETUP (RETUNE) ALL BOOM SECTIONS NEED TO MOVE.**
- **PERSONNEL AND EQUIPMENT MUST BE CLEAR OF ALL BOOMS.**
- **MAKE SURE ALL BOOMS HAVE ROOM TO LIFT FULLY AND ARE CLEAR OF POWER LINES.**

6.1.1 STEP 1: Prepare the Equipment (1)

Unfold the sprayer in a location that is relatively level, and where the sensors are over bare soil or gravel.

Do not conduct the System Setup or **ReTune** procedure over standing crop, or tall weeds/grass.

6.1.2 STEP 2: Prepare the Equipment (2)

Check the pads between the sprayer boom and the boom carrier frame to ensure no friction because of wear. Use grease or other lubricants, if necessary.

This is important and will increase the UC4+ Spray Height Control system performance significantly, especially on Active Roll systems.

6.1.3 STEP 3: Prepare the Equipment (3)

Start the solution pump and run the sprayer's engine at a normal working RPM for the entire setup.

Make sure that you can manually adjust the height of all your booms. If your manual controls do not work normally, check the UC4+ Installation Manual that came with your kit for troubleshooting information.

For best results, the hydraulic system should be under a normal load and at a normal working temperature. An effective way to warm the oil is to cycle all boom sections up and down manually for 5 minutes. Longer warm up times may be required in cold weather. For pull-type sprayers, ensure any hydraulic flow controls are adjusted for normal field operation.

NOTE: Changing the flow controls during or after System Setup will affect UC4+ operation.

6.1.4 STEP 4: Turn On the UC4+ Control Panel.

If this is the first setup for the panel, this process will begin automatically. If the panel was previously setup, you need to select "Install?" from the **SETUP** menu to initiate Automatic System Setup.

*If other messages appear on the LCD screen during the following steps, refer to **Section 9.1** for more information.*

6.1.5 STEP 5: Select the Sprayer Type

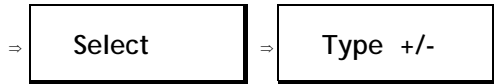

- Use the " +/- " switch to toggle through a list of available sprayer types. The types are listed in **Section 11** on page 54.

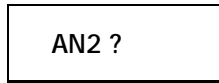

- When the desired type is shown, confirm the selection with the "AUTO (YES)" switch. Toggle "SETUP (NO)" to exit.

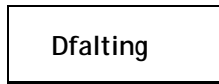

- The control panel is loading all the settings for your sprayer.

6.1.6 STEP 6: Wiring Test *

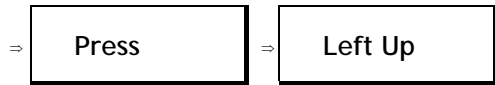

- Use the sprayer's manual controls to move the left boom up.
- If the wrong boom moves or if the direction is incorrect, stop the setup. Consult the UC4+ Installation Manual to check the hydraulic plumbing and electrical wiring of your system. Turn on the control panel again to resume the system setup.

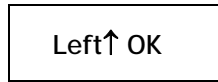

- Control panel confirms the wiring is correct.
- Continue the process with the remaining booms, as shown below.

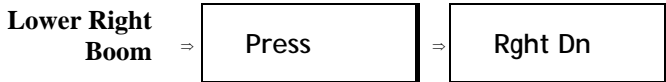
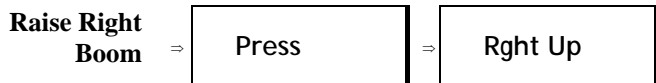

* *Some sprayer types do not support a wiring test or they may support a different style of test. If you do not see any of the messages in this step, simply continue as prompted by the panel.*

** *These prompts are only shown for sprayer types that support automatic main boom height control.*

6.1.7 STEP 7: Sensor Detect

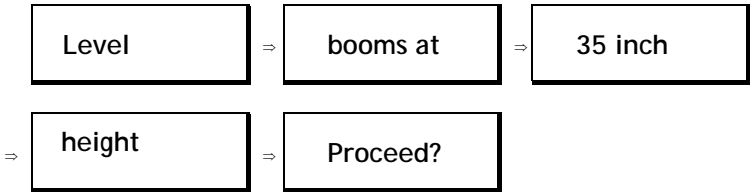

- If you have main boom roll control, manually level the boom.
- Position all other boom sections such that the nozzles are 90 cm (35 inches) from the ground.
- Toggle "**AUTO (YES)**" to continue.

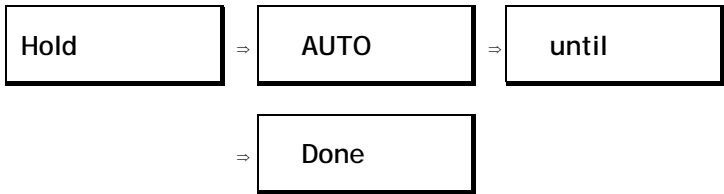

- Hold the "**AUTO (YES)**" switch to begin the sensor detect sequence. During the procedure you must hold the "**AUTO (YES)**" switch. If "**AUTO (YES)**" is released, simply toggle and hold again to continue the procedure.
- The control panel reads the serial numbers of all connected sensors.

3 Sensrs

- Number of sensors found is displayed. This should match the number of sensors on your system. If it does not, turn off the control panel and ensure that all sensors are plugged in and operating.
- The control panel indicates the progress through the detection stage.

6.1.8 STEP 8: Boom Geometry Tuning

- Do not activate any hydraulic functions during this step.
-

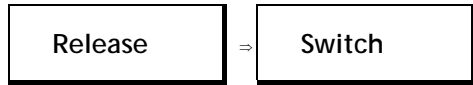

- Release the "AUTO (YES)" switch to continue.

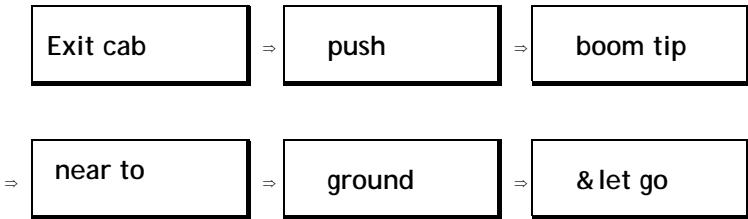

- Exit the cab of the machine and manually push either boom tip near to the ground for a moment and then let go. *

 **CAUTION!:**

DO NOT WALK NEAR THE SENSORS WHEN APPROACHING THE BOOM. STAY AT LEAST 3 FEET FROM THE SENSOR IN ORDER NOT TO INDUCE MEASUREMENT ERROR.

- Push either boom tip such that the tip moves at least 15 inches (more if you can).
- Once the control panel has detected your sprayer's geometry, the next menu prompt will appear.
- Toggle "SETUP (NO)" or toggle and hold "AUTO (YES)" at this menu to accept the default parameters and continue.

**This step is not applicable to system type GN2*

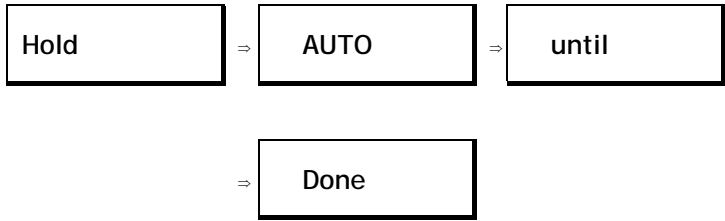

- Hold the "**AUTO (YES)**" switch to continue the boom geometry tuning. If "**AUTO (YES)**" is released before "**Done**" is displayed, simply toggle and hold again to continue the procedure.
- The panel will display various messages as it is working. The messages are displayed for informational purposes only.

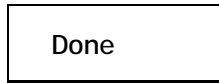

- Release the "AUTO (YES)" switch, the boom geometry tuning is complete.

6.1.9 STEP 9: Control System Test

M 84 M

- Normal Operating Screen is shown above.

⚠ CAUTION!:

IN THE FOLLOWING PROCEDURE, SWITCH THE CONTROL PANEL TO MANUAL MODE IMMEDIATELY IF THE BOOM MOVEMENTS ARE ERRATIC.

- Toggle "AUTO (YES)" to start AUTO mode. Observe the behavior of the booms while correcting to the target height.

A 115 A

- The operating screen shows the system is in AUTO mode and the target height is 114 cm (45 inches).
- The boom movements should be smooth and stable. Boom corrections should stop after a few seconds, under normal conditions (excessive wind may cause small corrections to continue).

A 116 A

- Toggle the "MANUAL" switch to return to MANUAL mode.
- If the boom corrections are done in an acceptable manner your system is ready to use.

Automatic System Setup Complete

6.2 ReTUNE

From time to time it may be necessary to recalibrate (**ReTune**) the UC4+ electronics to your sprayer's hydraulics. Examples of such times are:

- when a hydraulic solenoid valve is changed
- when the hydraulic pump is changed or adjusted
- when the normal working temperature of the hydraulic oil has shifted significantly from when the system was previously calibrated

If you are running a pull type sprayer and use different tractors to operate the sprayer, you should run the **ReTune** procedure each time the tractor is changed. If you have a flow control for the boom hydraulics, set it prior to tuning. If you change the flow setting by more than 20 percent, you should **ReTune**.

Follow **Section 6.1.1** to **6.1.3** (level booms, working RPM, etc.) before beginning the **ReTune**. Navigate to the "ReTune?" menu prompt in the **SETUP** menu and confirm with the "AUTO (YES)" switch. The procedure described in the **Automatic System Setup**, starting at **6.1.7** will begin.

NOTE: The booms are to be leveled at a normal working height when ReTune starts – it is not necessary to set them to 35 inches. The 35 inch height is only required during the Automatic/Manual System Setup.

6.3 MANUAL SYSTEM SETUP

The UC4+ control panel will not permit **AUTO** mode unless the system has been completely configured by either the Automatic System Setup or Manual System Setup. Manual Setup will require setting up each sensor (programming serial numbers and sensor locations) as well as tuning the hydraulic parameters manually.

6.3.1 Setting Up Sensors

Table 4 – Left Channel SENSOR DISPLAY Menus

Navigating past the end of the menu will return the panel to the Sensor..."More" Menu	
LI off	Informs you that no left inside (LI) sensor is installed; or else shows the information as described for LO.
LOht 115	Informs you that the current height reading of the LO sensor is 115 cm (45 inches).
LO 1240	Informs you that serial number 1240 is installed as the left outer (LO) sensor.
Navigating past the end of the menu will return the panel to the Sensor..."More" Menu	

Sensor information (serial numbers, locations) can be entered in the **SENSOR DISPLAY** menu manually. You need to know the serial number of the sensor you wish to enter and the physical location. The serial number is stamped on the sensor housing opposite the cable.

The left channel menu prompts are described in **Table 4**. For the other channels, the basic structure and behavior of the prompts is the same.

Entering Sensor Serial Numbers

To enter a sensor serial number in one of the boom locations:

1. Ensure the UC4+ control panel is in **MANUAL** mode, at the Normal Operating Screen.
2. Navigate to the "More ?" menu prompt in the **SENSOR DISPLAY** menu. Toggle "**AUTO (YES)**" to confirm.
3. Navigate to the boom section you put the sensor on, for example, "Right ?", if the sensor is mounted on the right hand boom. Toggle "**AUTO (YES)**" switch.
4. Navigate to the boom location you mounted the sensor on, for example, "LO" for the left outer sensor. This screen will show the previously installed sensor serial number (if any) as shown in **Table 4**.
5. Toggle the "+" switch once to search for the all connected sensors.

6. Use the "+" switch to toggle through a list of available sensor serial numbers. If you wish to turn this sensor off, toggle "-" switch.
7. When the desired serial number is shown, toggle "AUTO (YES)" switch to confirm.
8. Proceed to "LOht" menu prompt to check/calibrate the sensor's height reading (see next section).
9. Toggle and hold "SETUP (NO)" switch for two seconds to return to the Normal Operating Screen.

Calibrating the Sensor's Height Reading (Zero Height)

1. Ensure the sprayer boom is unfolded and the sensors are located over bare soil or gravel. Position the boom at a normal working height. Do not conduct this procedure over standing crop or tall grass/weedy areas.
2. Using a tape measure, measure the distance from the bottom of the spray nozzle closest to the sensor to the ground. Round this measurement to the nearest half-inch.
3. Navigate to the "LOht" menu prompt as described in the previous section.
4. If the currently displayed height reading is not correct, adjust it using the "+/-" switch. The "+" switch will increase the reading, the "-" switch will decrease the reading.
5. To return to the Normal Operating Screen, toggle and hold "SETUP (NO)" switch for two seconds.

Options for Main Boom Sensor in Wheel Track

Mounting the main boom sensor directly behind a sprayer tire may impair main lift control when operating in **CROP** mode. Height readings from crop that is flattened by the sprayer wheel do not provide an accurate measurement of canopy height, resulting in poor performance (**Section 5.2.4**). Two possible solutions are explained below.

A. Turning the Main (Center) Section Off

This workaround will disable the main section's **AUTOMATIC** control; however, manual height readings from this section will still be available. The sprayer's wing booms will still be controlled automatically. Perform the following procedure:

1. Ensure the UC4+ control panel is in **MANUAL** mode, at the Normal Operating Screen.
2. Navigate to the "More ?" prompt in the **SETUP** menu. Toggle "AUTO (YES)" switch.
3. Navigate to the "Main ?" prompt in the **SETUP** menu. Toggle "AUTO (YES)" switch.

4. At the "Main On" prompt, toggle the "+/-" switch to change to "Main Off".

Main Off

5. Toggle and hold "SETUP (NO)" switch for two seconds to return to the Normal Operational Screen.

B. Adjusting the Sensor Offset

To compensate for the lack of crop in the "wheel track", adjust the main lift sensor's height reading offset (zero height) so that the sensor will read higher to match the average height of your crop. Perform the following procedure using the UC4+ control panel:

1. Ensure the UC4+ control panel is in **MANUAL** mode, at the Normal Operating Screen.
2. Navigate to the "More ?" prompt in the **SENSOR DISPLAY** menu. Toggle "AUTO (YES)" switch.
3. Navigate to the "Main ?" prompt in the **SENSOR DISPLAY** menu. Toggle "AUTO (YES)" switch.
4. Toggle "SENSOR DISPLAY" switch to display the main lift height ("MLht") menu prompt.

MLht 47

5. Decrease the reading by the difference in height between standing crop and trampled crop in the "wheel track". Adjust this until **ALL** three sections (right, left, main) are level in the field while in **AUTO** mode. The "+" switch will increase the reading, the "-" switch will decrease the reading.

NOTE: This may take some experimentation in field conditions.

6. To return to the Normal Operating Screen, toggle and hold "SETUP (NO)" switch for two seconds.

NOTE: This is subject to a "trial and error" approach to getting this set adequately. The advantage is that AUTOMATIC control will be retained for the main section. Depending on the crop, the depression caused by the wheel might vary. Keep in mind that when turning the implement the "wheel track" will follow a different path. If the main roll sensor detects standing crop in this situation, the main section will lift momentarily.

NOTE: Zero height (for the main lift sensor) will need to be reset when using SOIL mode operation.

6.3.2 Setting Up Hydraulic Valves

There are two key settings for each valve direction (for example, the left up direction). These settings are valve DeadZone, "DZ", and valve GAIN, "KP".

The DeadZone ("DZ") setting represents the size of electrical signal required at the solenoid valve to cause a boom speed of one inch per second.

The GAIN ("KP") setting is inversely related to the maximum speed of the boom. That is, the faster the boom the lower the GAIN setting.

The left channel is described in **Table 5**. For the other channels the basic structure and behavior is the same.

Table 5 – Left Channel SETUP Menus

Navigating past the end of the menu will return the panel to the Setup..."More" Menu	
Left On	Informs you that the left valve channel is ON. To change the status to OFF, use the " +/- " switch (Section 6.3.5).
↑DZ- 100	Informs you that the left up DeadZone setting is 100. To adjust the reading use the " +/- " switch.
↑KP- 53	Informs you that the left up GAIN setting is 53. To adjust the reading use the " +/- " switch.
↓DZ- 100	Informs you that the left down DeadZone setting is 100. To adjust the reading use the " +/- " switch.
↓KP- 42	Informs you that the left down GAIN setting is 42. To adjust the reading use the " +/- " switch.
Navigating past the end of the menu will return the panel to the Setup..."More" Menu	

These settings will be determined during the Automatic System Setup (**Section 6.1**) and "ReTune?" (**Section 6.2**) sequences automatically. However, it is possible to check and adjust these settings manually as described below.

6.3.3 Valve DeadZone Test

1. Follow the steps, **6.1.1** to **6.1.3** (level booms, working RPM, etc.), before proceeding.
2. Ensure the UC4+ control panel is in **MANUAL** mode, at the Normal Operating Screen.
3. Navigate to the "More ?" menu prompt in the **SETUP** menu Toggle the "**AUTO (YES)**" switch to confirm.
4. Navigate to the boom section you wish to setup, for example, "**Right ?**" to adjust the right up and/or the right down settings. Toggle the "**AUTO (YES)**" switch to confirm.
5. Toggle the "**SETUP (NO)**" switch to access the next menu prompt, in this case the right up DeadZone ("**-DZ↑**").
6. While viewing the DeadZone ("**DZ**") menu prompt, perform one of the two tests: AUTO DeadZone Test or Manual DeadZone Test.

NOTE: You do not need to run both the AUTO and Manual tests. The tests are entirely independent.

a) Auto DeadZone Test

- Toggle and hold the "**AUTO (YES)**" switch.
- When the "**Done**" message is displayed, release the "**AUTO (YES)**" switch to view the new setting.

b) Manual DeadZone Test

- Toggle and hold the "**MANUAL**" switch.
- The valve will turn on at the indicated setting for exactly one-second. The LCD screen will show the actual change in height.
- The change in height reading is live as long as you hold the "**MANUAL**" switch. Wait until the height reading has settled to a stable value and record this reading.
- Average your three readings. The acceptable average change in height should be from 13 to 38 mm (0.5 to 1.5 inches) (ideal would be 25 mm (1 inch) exactly).
- If the average is less, increase the **DZ** setting with the "**+/-**" switch. If the average is more, decrease the **DZ** setting with the "**+/-**" switch.
- Repeat the Manual Dead Zone Test until the average falls into the acceptable range.

6.3.4 Valve Gain Test

1. Follow the steps, **6.1.1** to **6.1.3** (level booms, working RPM, etc.), before proceeding.
2. Ensure the UC4+ control panel is in **MANUAL** mode, at the Normal Operating Screen.
3. Navigate to the "More ?" menu prompt in the **SETUP** menu Toggle the "**AUTO (YES)**" switch to confirm.
4. Navigate to the boom section you wish to setup, for example "**Right ?**" to adjust the right up and/or the right down settings. Toggle the "**AUTO (YES)**" switch to confirm.
5. Toggle the "**SETUP (NO)**" switch twice to access the right up GAIN ("-KP↑") menu prompt.
6. While viewing the GAIN ("-KP↑") menu prompt, perform one of the two tests: AUTO GAIN Test or Manual GAIN Test.

NOTE: You do not need to run both the AUTO and Manual tests. The tests are entirely independent.

a) Auto Gain Test

- Toggle and hold the "**AUTO (YES)**" switch.
- When the "Done" message is displayed, release the "**AUTO (YES)**" switch to view the new setting.

b) Manual Gain Test



CAUTION!:

BEFORE CONTINUING MAKE SURE THE BOOM HAS ROOM TO MOVE IN THE INDICATED DIRECTION AT FULL SPEED FOR ONE SECOND. BE PARTICULARLY CAREFUL IF YOU ARE WORKING WITH THE ROLL CONTROL SECTION.

- Toggle and hold the "**MANUAL**" switch.
- The valve will turn on at 100 percent speed for exactly one-second. The LCD screen will show the actual change in height.
- The change in height reading is live as long as you hold the "**MANUAL**" switch. Wait until the height reading has settled to a stable value and record this reading. This is your boom speed in mm per second (mm/s) or inches per second (in/s) if inches is the selected units.
- Repeat the Manual Gain Test three times, repositioning the boom as necessary.
- Average your three readings. Typical values are between 15 and 50 inches/sec.

- Set the Gain value using the " +/- " switch using the tables below as a guideline. Right and left Gain settings are polarized for direction as shown in **Table 6**.

NOTE: Gain values depend on many more factors than just speed, and therefore are best set automatically or by an experienced operator.

NOTE: Test the response at a sensitivity (Sensi) of five, because the Sensi setting will scale the Gain settings (Section 5.1.1). If the booms are not reacting quickly enough a higher Gain setting will make the boom respond faster. If the booms are too jerky or unstable, you must lower the Gain setting or improve the boom's mechanical damping.

Table 6 – Right, Left Booms

Boom Speed (in/s)	Up Gain Setting (↑KP)	Down Gain Setting (↓KP)
Less than 5	Too Slow	Too Slow
5-15	225-175	100-70
15-25	175-150	70-50
25-40	150-100	50-30
40-70	100-50	30-15
Greater than 70	50-1	15-1

Table 7 – Main (Center) Boom

Boom Speed (in/s)	Gain Setting (KP)
1-5	100-75
5-10	75-50
10-15	50-30
15-20	30-15

Table 8 – Roll Section

Boom Speed (in/s)	Gain Setting (KP)
<10	225-254
10-15	175-225
15-20	175-200
>20	150-100

6.3.5 Turning Booms OFF or ON

You can turn UC4+ automatic height control off for each individual boom section. In **AUTO** mode, boom sections that are turned off will not automatically adjust, and are indicated with a "D" in the Normal Operating Screen, as shown below.

Table 9 – Turning Left Boom OFF

D 88 A	Left boom is turned OFF ("D" = disabled) control, the current average boom height = 88 Right boom is in AUTOMATIC mode.
--------	--

Sections can be turned off or on in the **SETUP** menu. Refer to the menu structure shown in **Table 5**. Locate the menu prompts named below.

1. Ensure the UC4+ control panel is in **MANUAL** mode, at the Normal Operating Screen.
2. Navigate to the "More ?" menu prompt in the **SETUP** menu. Toggle the "AUTO (YES)" switch to confirm.
3. Navigate to the boom section you wish to turn off or on, for example "Right ?". Toggle the "AUTO (YES)" switch to confirm.
4. At the "Right On" menu prompt toggle the " +/- " switch to change the status.
5. Toggle and hold the "SETUP" switch for two seconds to return to the Normal Operational Screen.

6.3.6 Remote Switches

Remote control of the **AUTO** and **MANUAL** modes may be wired to the control panel. This feature allows the operator to control the mode of the UC4+ Spray Height Control system from an external switch or controller. Contact NORAC for further information concerning wiring and enabling Remote Switch control.

6.4 QUICK INSTALL

The Quick Install feature of the UC4+ Spray Height Control system is designed to help diagnose problems that cannot be identified during the Automatic Setup. It will instantly setup the system with typical values for valve calibration and sprayer geometry, based on the sprayer type selected.

Perform the following procedure for a Quick Install

◆ **STANDARD SYSTEM** (Including Passive Roll)

- A1.** Your system must have a minimum of two sensors.
- A2.** Verify the sensors are installed with the lowest serial number on the left side increasing to the highest serial number on the right side (Refer to the UC4+ Installation Manual).
- A3.** Level the boom at 35 inches height.
- A4.** Navigate in the **SETUP** menu to the "Install?" screen and toggle "**AUTO (YES)**" switch.
- A5.** At the "Select" "Type +/-" menu prompt, select the appropriate type for your sprayer (e.g. JD7). Sprayer types are listed on page **54**
- A6.** Toggle and hold "**AUTO (YES)**" for 5 seconds.
- A7.** When the word "**Sensor**" is displayed, release the switch. Your system will be configured with the standard settings based on the type you have selected and the number of sensors present.
- A8.** Perform a **ReTune** (**Section 6.2**).

◆ **ACTIVE ROLL SYTEM**

- B1.** Perform the Quick Install for **STANDARD SYSTEM A1** to **A7**, as described above.
- B2.** Navigate to the "Roll ?" menu prompt in the **SETUP** menu. Toggle "**AUTO (YES)**", and then change it to "Roll OnA" using the "**+/-**" switch. Toggle "**AUTO (YES)**" to confirm.
- B3.** Navigate to the "Roll ?" menu prompt in the **SENSOR DISPLAY** menu. Toggle "**AUTO (YES)**", and then set the "**IFh**" (intermediate frame height) and "**BFh**" (boom frame height) to zero using the "**+/-**" switch. Toggle "**AUTO (YES)**" to confirm.
- B4.** Perform a **ReTune** (**Section 6.2**).

7 MAINTENANCE

The UC4+ Sprayer Boom Height Control System requires very little maintenance. However, some minor procedures will help ensure that your system operates properly for many years.

Before each day of operation:

- ✓ Peak performance requires low friction on the boom roll mechanism. Used to hold the boom stable, friction pads are often prone to high amounts of friction when dry. Grease as necessary. This is especially important on systems equipped with Active Roll control.
- ✓ Ensure breakaway brackets are well lubricated and function properly.
- ✓ Clear any obstructions between the sensor and the ground. Any object within a 15 cm (6 inch) diameter circle directly below the sensor could cause improper height readings. Check to ensure hydraulic hoses, sensor cables, or debris is clear of the sensor.
- ✓ Inspect the foam insert in each sensor. Fitted into the bottom of the sensor is a foam shield that can become clogged with dust and dirt. Remove the foam from the sensor, blow it out with an air compressor if available, and reinsert. Replace the foam inserts as necessary.

***** IMPORTANT *****

Do not blow out the foam shield while it is still installed in the sensor. Sensor damage may result. Always remove the foam shield for cleaning.

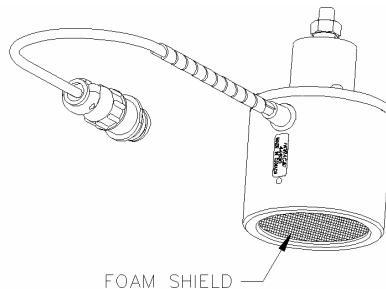

Figure 9 – Protective Foam Shield

At the End of a season:

- ✓ Remove the sensors and store inside.
- ✓ Replace oil filter in the NORAC hydraulic manifold (PT#: 104827) annually.
- ✓ Replace ultrasonic transducer as needed. Over time, performance of the inexpensive transducer element may become degraded from airborne contamination (typical life is 3-10 years). Contact NORAC for information.

8 TROUBLESHOOTING

- This section discusses common symptoms and suggested solutions when the UC4+ control system is being installed or operated.

8.1 GENERAL OPERATION

8.1.1

- **LCD screen does not light up**
- **System resets itself when a boom valve is turned on**

Possible Cause(s)	Suggested Solution(s)
a) Inadequate power supply NOTE: If your system is operating below +12 volts, this may cause a problem. If you have a low voltage problem, it could be due to the sprayer's electrical system (e.g. faulty alternator, battery, or poor ground connection).	a-1) Ensure the UC4+ power cable is connected to the UC4+ control panel. a-2) Ensure the UC4+ power cable is connected to the sprayer's power supply properly. a-3) Ensure the sprayer's power supply voltage is high enough (more than +12V). Measure the supply voltage when the valve is being used, since the valve action may cause a voltage drop.
b) Defective power cable	b) Follow a-1) to a-3). Wiggle cables/wires around. If the symptom continues, the cable may need repairing.
c) Damaged LCD screen	c) Follow a) and b). If the symptom continues, the screen may need replacing.

8.1.2

- **Part of the LCD screen is black**
- **Some of the digits do not appear on the LCD screen**
- **LCD screen turns black (high contrast) temporarily**

Possible Cause(s)	Suggested Solution(s)
a) The control panel is mounted so that direct sunlight hits the front panel (LCD screen)	a) High temperature causes the LCD screen to turn black (high contrast). This symptom will disappear when the LCD cools down.

8.1.3

- UC4+ randomly switches between AUTO and MANUAL modes
- LCD screen display changes erratically
- UC4+ Spray Height Control system unintentionally goes into MANUAL mode

Possible Cause(s)	Suggested Solution(s)
a) Poor cable connection NOTE: Connectors used to interface with sprayer hydraulics are often located outside and are susceptible to moisture.	a-1) Ensure that all cables are correctly connected according to the UC4+ Installation Manual. The connections should be tight and free of corrosion. a-2) Wiggle cables/wires around while in AUTO mode. This will detect any interruptions, as it will change the system into MANUAL mode.
b) Defective cable(s)	b) Follow a-1) and a-2). If the symptom continues, the cable may need repairing.
c) Electrical noise on the sprayer's D.C. system	c) Add a power line filter or freewheeling diodes on one or more of the sprayer's solenoid valves.

8.1.4

- Height increases/decreases unintentionally

Possible Cause(s)	Suggested Solution(s)
a) Intermittent electrical noise on the main lift interface cable(s). NOTE: This is similar to when the operator momentarily presses main up/down buttons to increase/decrease the spray height setpoint (Section 4.2.5).	a-1) Try installing a power line filter. a-2) Diodes may have to be installed in the main lift lines (these must be sized appropriately for the sprayer ex. IN5408 for a 3 Amp or smaller coil). Contact NORAC for more information.

8.1.5

- UC4+ Spray Height Control system does not go into AUTO mode

Possible Cause(s)	Suggested Solution(s)
a) Incomplete System Setup (Install)	Perform an Install successfully (see Section 4.1 of the UC4+ Operators Manual).
b) Accidentally initiated an "Install" and aborted it before completion	

8.1.6

- Boom does not appear to be sufficiently level after System Setup

Possible Cause(s)	Suggested Solution(s)
a) Sensitivity (Sensi) setting is low	a-1) Check the average nozzle height on LCD screen in MANUAL mode. a-2) If the displayed heights differ from the target heights (setpoints), check Sensi setting and adjust it, if necessary. NOTE: The default tolerate distance between the actual nozzle heights and the target heights is $\pm 6\text{cm}$ (± 2.5 inches) at Sensi setting of 5.
b) Improper System Setup	b-1) Repeat the Automatic System Setup (Section 8.2 of the UC4+ Operators Manual). b-2) Confirm sensor height readings manually by referring to “Calibrating the Sensor’s Height Reading (Zero Height)” in the UC4+ Operators Manual.

8.2 SENSOR RELATED ISSUES

8.2.1

- **Display stuck at "'Mot'n Dly" or "KP Stp 9"**

Possible Cause(s)	Suggested Solution(s)
a) Sensor is too close to the boom	a) Move the sensor to a better location. It should be 25cm (9 inches) in front of and 25cm (9 inches) above the spray nozzle. The sensor requires a 30cm (12 inch) diameter clear view of the ground.
b) The target is too weak	b-1) Move to a new location with either dirt or gravel on the ground. b-2) Make sure there is no grass or other plants under the sprayer boom. b-3) Verify the sensor is approximately parallel to the ground.

8.2.2

- **Sensor appears not to work: Displaying "NC"**
- **Wrong number of sensors displayed during System Setup**
- **Displaying "Absent" during System Setup – Sensor Detect**

Possible Cause(s)	Suggested Solution(s)
a) Serial number (SN) entered in the control panel does not match the connected sensor's SN	a) Check SNs entered in the control panel and verify numbers with each sensor in the respective boom location. Reenter the correct SN, if necessary.
b) Poor cable connection or defective cable(s)	b-1) Ensure that all cables are correctly connected according to the UC4+ Installation Manual and perform Sensor Swapping described in 8.2.6. If the symptom continues, the cable(s) may need repairing. b-2) Ensure the sensor cables are not strained or pinched by boom fold actions.
c) Damaged sensor	c) Follow b-1). If the symptom appears in the moved boom location, the sensor may need repairing.

8.2.3

- **Invalid sensor measurement: Displaying "NR"**

Possible Cause(s)	Suggested Solution(s)
a) Sensor is out of range or reading a target closer than 18cm (7 inches)	a-1) Move the boom(s) until sensor(s) is between 80 and 150cm (30 and 60 inches) above the ground. a-2) Check sensor alignment (Section 8.2.7). NOTE: If the sensor is facing forward/backward too far, the signal cannot echo back to the sensor. a-3) Check for obstructions between the sensor and the ground. NOTE: Any object between them can deflect the signal such that it cannot echo back to the sensor.
b) Protective foam shield is contaminated	b) Inspect and clean the foam shield. Remove the foam and clean with compressed air. NOTE: Do not blow out the foam while it is still in the sensor. Sensor damage will result.
c-1) Moisture in sensor c-2) Direct exposure to rain NOTE: It may cause this error especially if the sensor mouth points upward while sprayer booms are folded to transport position. Measures should be taken to minimize rain exposure to sensors.	c-1) Remove the protective foam shield and check the sensor's transducer foil. c-2) Allow the transducer to dry. NOTE: The foil is the gold-colored material beneath the metal screen. The foil should be clean, dry and wrinkle free. NOTE: Running the sensor will accelerate the drying effect.
d) Ultrasonic transducer is damaged or contaminated	d) Follow a) to c-1), and listen to the sensor for a ticking sound. If the sensor is not ticking or the transducer is contaminated, the sensor may need repairing.

8.2.4

- **Displaying "SNR xxxx" during Automatic System Setup**

Possible Cause(s)	Suggested Solution(s)
a) Improper sensor alignment NOTE: Sensor is not reading the ground properly	a) Check sensor alignment (Section 8.2.7), primarily the sensor involved with the error. For example, if the System Setup is performing a "LftDet" and this message appears, check the Left wing sensor(s).
b) Poor targets such as wet gravel or stubble	b) Try a different target.

8.2.5

- **Sensor not working: Displaying "###" or "-##" (too high or low)**

Possible Cause(s)	Suggested Solution(s)
a) Boom section is too high ("###").	a) Lower the boom section. NOTE: The sensor is reporting a reading that has too many digits to display on the LCD screen. When the boom returns to normal heights, the reading should reappear on the screen.
b) Sensor Zero Height setting is incorrect	b) Check the sensor "Zero Height". Calibrate, if necessary. NOTE: Refer to Section 6.3.1 Calibrating the Sensor's Height Reading in the UC4+ Operators Manual. NOTE: This symptom may occur when sensors have been "swapped" from different mounting locations.
c) Sensor is facing very strong sonic targets (e.g. concrete) NOTE: This may cause measurement errors, flashing from a valid height reading to "0", "###" or "-##"	c) Try a different/adequate target.

8.2.6 Sensor Swapping

Swapping Sensors is a useful procedure for determining whether a sensor error message (e.g. "LO NR") is due to the sensor or the wiring to the sensor.

NOTE: A sensor may have power and emit a ticking sound, but have broken communication wire(s), which would cause this error. Performing Sensor Swapping would help determining the cause.

The procedure is as follows:

- i) **Exchange the affected sensor with one that is reporting correctly (e.g. "LO" and "RO").**
- ii) **Swap (input) their respective location serial numbers into the control panel (Section 6.3.1).**
- iii) **If the problem still exists in the same location, the wiring from that branch may have a fault.**
- iv) **If the error appears in the new location, the sensor may not be functioning properly.**

8.2.7 Sensor Alignment

Proper sensor alignment is critical in order for UC4+ performance. The majority of problems reported by operators in the field are due to improper sensor mounting.

Wing Sensors

- When the boom is in its lowest position, the sensor mouth must be 22cm (9 inches) or more above the spray nozzles.
- The bottom of the sensor must be at least 25cm (9 inches) in front of the nozzles.
- The sensor must be approximately vertical at normal operating heights.
- Ensure that there are no obstructions within a 30cm (12 inch) diameter circle projected directly below the sensor.
- When mounting or relocating sensor brackets, ensure they do not interfere with boom folding operation.
- When mounting to the top part of the boom (as shown in **Figure 10**), check that the sensor can not read off the bottom part of the boom. This is most common in **CROP** mode

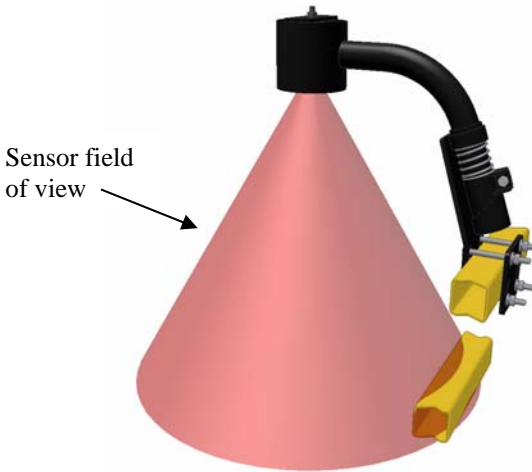

Figure 10 – Sensor Reading of the Boom

8.3 HYDRAULIC RELATED ISSUES

- Determine whether the problem is hydraulic or electrical
- If your hydraulic valve has an override pin, use it to manually open the valve
- If there is no reaction the problem is hydraulic, if the boom moves the problem may be electrical

NOTE: If there is a bypass valve with the hydraulic system, the bypass valve is also needed to open at same time as with the tested valve.

8.3.1

- **Boom(s) will not raise or lower**

Possible Cause(s)	Suggested Solution(s)
a) Hydraulic oil is not being supplied to the NORAC valve block	a) Ensure that oil is being supplied to the NORAC valve block in the proper direction (Tank and Pressure lines). NOTE: If the direction is wrong, the check valve may prevent oil from flowing through the valve.
b) Hydraulic quick couplers are not properly connected	b) Ensure that all quick couplers in the hydraulic system are properly connected.
c) Not enough back-pressure to activate the check valves in the NORAC valve block NOTE: Some Single Acting valve systems only	c) Place orifices in the "A" lines going to Tank ("T") in order to create sufficient back-pressure to activate the pilot-operated check valves in the NORAC valve block.
d) Poor cable connection, defective cable(s) or defect in the NORAC valve block	d-1) Check all cable connections between the control panel and the valve block. Ensure that they are tight and free of corrosion. d-2) Check the LCD screen in which the valve command arrows ("↑" or "↓") appear. d-3) Measure the voltage at the valve connection. d-4) If there is no voltage, the cable(s) may need repairing or replacing. d-5) If there is sufficient voltage (+12V), and the valve is not reacting, the valve may need repairing or replacing.

8.3.2

- Booms will not lower

Possible Cause(s)	Suggested Solution(s)
a) Insufficient back-pressure to activate the pilot-operated check valves in the NORAC valve block	a) Some single acting circuits may require orifices to be placed in the “A” lines going to the tank.

8.3.3

- "Timeout!" error during System Setup

Possible Cause(s)	Suggested Solution(s)
a) Hydraulic cylinder has reached the end of its stroke but the system is still trying to move in that direction	<p>a-1) Ensure the hydraulic cylinders are not being prevented from moving by a cylinder cap.</p> <p>a-2) If a cylinder is fully extended or retracted, manually reposition the boom into the middle of the cylinder stroke and resume the setup with the "AUTO (YES)" switch.</p> <p>a-3) For left and right booms that do not adjust below the level of the main boom, ensure that the main boom is within 125cm (50 inches) above ground before attempting an Install or ReTune.</p>
b) Boom is moving too slow	b) Ensure the hydraulic oil is at working temperature.
<p>c) Not enough pressure to the hydraulic circuits at main lift ("MifDet") Boom Geometry Tuning</p> <p>NOTE: This is for sprayers with load-sensing hydraulic circuits.</p>	<p>c-1) Ensure the solution pump is running.</p> <p>c-2) Put the hydraulic system into high pressure manually.</p> <p>NOTE: On a John Deere sprayer, this can be accomplished by pressing and holding the brake.</p>
d) The sensor may be reading off the boom	d-1) Move the sensor to a location where the boom will not interfere with the sensor readings

8.3.4

- **Boom raises when it should lower, or vice versa**

Possible Cause(s)	Suggested Solution(s)
a) Wrong valve cable connection	a) Ensure cable connection to the NORAC valve block
b) Wrong plumbing	b) Ensure the plumbing is correct: <ul style="list-style-type: none"> • The boom raise line(s) connect(s) to the “B” port(s) on the NORAC valve block. • The boom lower line(s) connect(s) to the “A” port(s) on the NORAC valve block. • The Tank and Pressure lines connect to the Tank (“T”) port and Pressure (“P”) port on the NORAC valve block, respectively.

8.3.5

- **Boom(s) creep up or down in MANUAL mode**
- **Boom will not stay level or settle over a long period of time**

Possible Cause(s)	Suggested Solution(s)
a) Internal problem with the NORAC valve block (e.g. a sticking or worn valve)	a) The valve block may need repairing or replacing.
b) Cylinder leakage	b) The cylinder seals may need replacing.
c) Faulty check valve(s) in the NORAC valve block	c) The check valve(s) may need replacing.
d) Foreign object stuck in an internal port of the NORAC valve	d) If possible, remove the foreign object or the valve block may need repairing.
e) Not enough back-pressure to activate the check valves in the NORAC valve block NOTE: Some Single Acting valve systems only	e) Place orifices in the “A” lines going to Tank (“T”) in order to create sufficient back-pressure to activate the pilot-operated check valves in the NORAC valve block.
f) Problem within the sprayer’s hydraulic network (system)	f) Check the sprayer’s hydraulic network.

8.3.6

- **Boom(s) creep(s) upwards when in the transport position**

Possible Cause(s)	Suggested Solution(s)
a) Valve leakage	a) The valve block may need repairing or replacing.
b) Faulty check valve(s) in the NORAC valve block	b) The check valve(s) may need replacing.

8.3.7

- **Hydraulic oil overheat**
- **Sprayer shuts down or alarm sounds due to the hydraulic oil overheat**

Possible Cause(s)	Suggested Solution(s)
a) Maintaining the setpoint is increasing oil temperature	a) Lowering the Sensitivity ("Sensi") setting may reduce the system activity and lower the temperature as a result.
b) Plumbing single acting systems as double acting with both A ports orificed may reduce heating	b) Contact NORAC for more information.
c) Depending on your type of system, other adjustments may be made.	

8.4 BOOM INSTABILITY AND MAIN LIFT

8.4.1

- Erratic or “jumpy” boom behavior (in CROP mode)
- Bouncing boom(s)

Possible Cause(s)	Suggested Solution(s)
a) Sensor readings from the crop canopy are less uniform than from soil	a) Tune the hydraulic system properly. NOTE: This symptom occasionally appears on the main lift control. If so desired, the main lift control may be disabled (Passive Roll control will still be functional).
b) Inappropriate accumulator(s) on lift hydraulics	b) Check the accumulator(s). Replace if necessary.

8.4.2

- Boom unintentionally moves all the way up in CROP mode

Possible Cause(s)	Suggested Solution(s)
a) Improper sensor alignment	a) Check sensor alignment (8.2.7). Ensure the sensor is not reading off the boom.

8.4.3

- Irregular boom movement or boom instability
- Control panel interferes with auto steer or rate controller operation

Possible Cause(s)	Suggested Solution(s)
a) Improper sensor alignment	a) Check sensor alignment (8.2.7). Ensure the sensor is not reading off the boom.
b) System conflict between devices (such as other automatic control devices)	b) May need plumbing changes or adjusting pump pressure settings. NOTE: This symptom may occur on sprayers that use load-sensing hydraulic systems.
c) Wear in boom damper shocks	c) Check the boom damper shocks. Replace them, if necessary. NOTE: Without adequate mechanical damping, the system may become unstable.
d) Wear in a mast-style lift system	d) Apply shims or filler strips to the mechanism, or adjust it, if applicable. NOTE: Some sprayer designs use a mast-style lift rather than parallel links. The sliding surfaces on some of these machines are susceptible to wear which leads to this symptom. The UC4+ Passive Roll control cannot take into account error on the lift mechanism.

9 SYSTEM MESSAGES

9.1 SETUP MESSAGES

- During an **Install** or **ReTune** if any of the following messages appear on the LCD screen, the system will halt any valve action and wait for operator acknowledgement.
- Some of these messages appear after the operator is prompted to "Release" "Switch" while holding "AUTO (YES)".
- Release the switch and correct the problem using Table 10.
- Exit the procedure by toggling the "SETUP (NO)" switch.

Table 10 – System Setup Error Messages

<div style="border: 1px solid black; padding: 5px; display: inline-block; margin-right: 10px;">TimeOut!</div> ⇒ <div style="border: 1px solid black; padding: 5px; display: inline-block;">Retry ?</div>		
Explanation	Possible Causes	Required Action
Boom Geometry Tuning has taken too long to complete.	<ul style="list-style-type: none"> a. Hydraulic cylinder has reached the end of its stroke, but the system is still trying to move in that direction. b. Boom is moving too slow. c. There is not enough hydraulic pressure to move the boom. d. If the boom was moving before this message appeared, this is probably not an error of concern. 	<ul style="list-style-type: none"> a. Follow 8.3.3 a). b. Follow 8.3.3 b). c. Follow 8.3.3 c). d. Some booms will take longer than others to calibrate, triggering a "Timeout!".
<div style="border: 1px solid black; padding: 5px; display: inline-block; margin-right: 10px;">Wiring!</div> ⇒ <div style="border: 1px solid black; padding: 5px; display: inline-block;">Retry ?</div>		
Explanation	Possible Causes	Required Action
Setup cannot proceed because the control panel cannot receive appropriate signal from a sensor.	<ul style="list-style-type: none"> a. Wrong or poor cable connection. b. Defective cable(s). c. Pressing the wrong switch on the sprayer's hand-control. 	<ul style="list-style-type: none"> a. Follow 8.1.3 a). b. Follow 8.1.3 b). c. Toggle the "AUTO (YES)" switch to restart the wiring test.

<div style="border: 1px solid black; padding: 5px; display: inline-block; margin-right: 10px;">SNR 2521</div> ⇒ <div style="border: 1px solid black; padding: 5px; display: inline-block;">Retry ?</div>		
Explanation	Possible Causes	Required Action

Setup cannot proceed because the indicated sensor is not returning a valid height reading. * The number is arbitrary	a. Improper sensor alignment.	a. Follow 8.2.4.
	b. Sensor is not reading the ground properly.	b. Follow 8.2.4.
	c. Faulty sensor.	c. Replace sensor.

SN=0 det ⇒ **Retry ?**

Explanation	Possible Causes	Required Action
At least one sensor has been detected with improper factory programming.	The sensor(s) was not set up properly at the factory.	Replace sensor(s).

Too Many ⇒ **Retry ?**

Explanation	Possible Causes	Required Action
The system has detected that too many sensors are connected.	Too many sensors have been connected to the system.	Remove sensors, or setup the system manually.

Bakwards ⇒ **Retry ?**

Explanation	Possible Causes	Required Action
Boom moves in the wrong direction.	a. Wiring or hydraulic plumbing problem.	a. Follow 8.3.4, 8.3.1 d).
	b. Extremely under-damped boom.	b. Add mechanical damping to the boom and/or consult NORAC.

TooHigh! or **TooLow!** ⇒ **Retry ?**

Explanation	Possible Causes	Required Action
Boom is positioned higher than 150cm (60°) or lower than 80cm (30°).	System Setup was started with the boom positioned too high or too low.	Follow 8.2.3 a), 8.2.5 and 8.3.3 a-3).

9.2 OPERATIONAL MESSAGES

- The following messages are non-critical messages that appear on the LCD screen when scrolling through the SENSOR DISPLAY menu from the Normal Operating Screen. Scrolling through the height display screens is a good place to start when troubleshooting because sensor errors will be displayed here. These error messages usually require some simple adjustment or setting changes.

Table 11 – Operational Messages

✚ NR 85		
Explanation	Possible Causes	Required Action
"NR" indicates the sensor is communicating but <u>Not Reading</u> a valid measurement.	a. Sensor is out of range or reading a target closer than 17cm (7"). b. Protective foam shield is contaminated. c. Moisture in sensor. d. Transducer is damaged or contaminated.	a. Follow 8.2.3 a). b. Follow 8.2.3 b). c. Follow 8.2.3 c-1),c-2). d. Follow 8.2.3 d).
NC 89✚		
Explanation	Possible Causes	Required Action
"NC" indicates <u>No Communication</u> from the sensor.	a. Serial number entered in control panel does not match connected sensor. b. Poor cable connection or defective cable(s). c. Damaged sensor.	a. Follow 8.2.2 a). b. Follow 8.2.2 b). c. Follow 8.2.2 c).
✚ ### 86		
Explanation	Possible Causes	Required Action
"###" is displayed if the sensor is reading a height greater than 250cm. It is commonly mistaken as an error.	a. Boom section is too high. b. Sensor Zero Height setting is incorrect. c. Sensor is facing very strong sonic targets (e.g. concrete).	a. Follow 8.2.5 a). b. Follow 8.2.5 b). c. Follow 8.2.5 c).
✚ -## 86		
Explanation	Possible Causes	Required Action

"-##" is displayed if the sensor is reading a height lower than - 25cm. It is commonly mistaken as an error.	<ul style="list-style-type: none"> a. Sensor Zero Height setting is incorrect. b. Sensor is facing very strong sonic targets (e.g. concrete). 	<ul style="list-style-type: none"> a. Follow 8.2.5 b). b. Follow 8.2.5 c).
--	---	--

LO NoRdg

Explanation	Possible Causes	Required Action
A sensor is not reading correctly. Similar error screens may replace the "LO" reading identifier with "LI", "ML", "RI", etc.	This is a sensor issue. * If this message is displayed very briefly, it may not be a problem.	Investigate the source of reading error with the identified sensor. Check that the sensor foil is clean.

Minimum Override

Explanation	Possible Causes	Required Action
This message is displayed when a target height setpoint is lower than allowed (minimum height override).	Operator is proceeding to use a lower target height setpoint than allowed.	Adjust the boom height setpoint greater than the minimum height override (Section 4.2.5).

Disabled

Explanation	Possible Causes	Required Action
Access to System Setup features (Install , ReTune) have been locked out.	Access to these features was disabled by installer to avoid unintentional system changes.	Contact NORAC for instructions to enable feature access.

1 Absent

Explanation	Possible Causes	Required Action
One of the configured sensors was not found during power up.	Sensor is not operating or is not connected.	Follow 8.2.2.

>>>>>>>

Explanation	Possible Causes	Required Action
The control panel is busy with a task that may take a few seconds.		Wait for the arrows to disappear before activating any control panel switches.

10 STATEMENT OF LIMITED WARRANTY

NORAC SYSTEMS INTERNATIONAL INC., also known as NORAC, warrants all equipment of its manufacture to be free of defects in material and workmanship for a period of one year. This warranty period is for a period of twelve months from the date the equipment is delivered by NORAC or its authorized dealer to the purchaser. Items include weighing systems, instrumentation, and control systems manufactured by NORAC. Auxiliary components not manufactured by NORAC such as tires, axles, pumps, or rebuilt parts are covered by a 6 month warranty only.

NORAC will repair free of charge items returned within the warranty period to one of NORAC's authorized Service Centers. Freight will be paid one way and returned by the same carrier unless instructed differently.

NORAC or its authorized Service Center will repair or replace, at its option, any defective part or component at no cost to the purchaser during the warranty period. If service in the field is required NORAC will authorize on-site repairs at no charge for parts and labor. Travel time, travel costs and per diem expenses to and from the place where repairs are made will be charged to the purchaser at prevailing rates.

For the nearest Service Center visit our website at www.norac.ca or call 306-664-6711.

Any evidence of, negligent or abnormal use, alteration of serial numbers, or repairs attempted by other than NORAC authorized personnel using NORAC certified or recommended parts, automatically voids the warranty. Normal wear is not covered under this warranty.

NORAC will not warranty any complaints relating to inadequate installation (unless the installation was performed by NORAC), adjustments or calibration.

The forgoing states the entire liability of NORAC regarding the purchase and use of its equipment. NORAC will not be held responsible for any consequential loss or damage of any kind.

This warranty is in lieu of all other warranties, except as set forth above. Any implied warranty merchantability or fitness for a particular purpose is hereby disclaimed. This warranty is in lieu of all other warranties, expressed or implied.

11 SPRAYER TYPES

Type	Sprayer Models
AN2	Generic Sprayer Boom
AND	Andros Engineering Vinyard Sprayer
AP1	Apache (Year 2001-2004)
AP2	Apache 2005+ (AS models)
BT1	Brandt OEM AR Type
BT2	Brandt Production Year 2001+
CS1	Case 4260, 4410 (Year 2000+)
CS2	Case 3150, 3185, 3200, 3310, Tyler Patriot
CS3	Case 4420, 3320
FC1	Flexi-Coil 67 Series 67 (Year 1999+)
FC2	Flexi-Coil/NH/CaseIH 68 Series, SF210/216, SRX100/160
FT1	Fast with Directional Manifold
FT2	Fast with Active Roll
FT5	Fast OEM Style Install 5 Station (Norac Grip)
FT6	Fast OEM Style Install 6 Station (Norac Grip)
GM1	Gregson Maverick 120 Series (Year 1999+)
GN1	Variable Geometry with Slow Roll Option (Metric)
GN2	Fixed (non-VG) Boom with Slow Roll Option (Metric)
GN3	Variable Geometry with Active Roll (Metric)
HD1	Hardi Retrofit Install North America
HD3	Hardi Factory Install – Australia
HD4	Hardi Factory Install – Denmark (Metric)
HG1	Hagie STS12
HG2	Hagie 2100, 2101
HG3	Hagie 2005 STS
HG4	Hagie STS 120 with Proportional Main Lift and Active Roll
JD6	John Deere 4920
JD7	John Deere 4720, 4710, 4700
JD8	John Deere 30 Series
JD9	John Deere 30 Series with Proportional Main Lift Control
NH1	New Holland SF550 and Rogator 554 (Year 2000+)
NT2	Nitro – Miller Technologies 120 Foot Boom
NT3	Nitro – Miller Technologies 90 Foot Boom
OM1	Original Equipment Manufacturer (NORAC Wiring & Grip)
PH1	Phoenix Telescoping Boom
RB1	RedBall 690
RG2	Rogator Sprayer 64 and 74 Series
RG4	Rogator Sprayer 854, 1054, and 1254 Series
RH1	RHS Bestway 1200/1600 with Main Lift Valve
RH2	RHS Bestway 1200/1600 with no Main Lift Valve
RP1	Raptor
SC1	Spray Coupe 7000 Series
SM1	Summers Pull-type
SS1	Sprayer Specialties
TA1	Top Air
WR1	Wilmar 8100/8500
WR2	Wilmar 8400/8600
ZX1	Generic Active Roll Type OEM Style (Norac Grip, Wiring)
ZX2	Generic Active Roll Type Retrofit

Table 12 – Sprayer Types

12 MENU STRUCTURE

Table 13 – Main Menu Structure

Navigating past the end of the menu will return the control panel to the Normal Operating Screen	
More ?	Toggle the "AUTO (YES)" switch to edit or view more sensor settings.
88 0 67	Displays diagnostics information used by technical staff.
↔ 56 ↔	Displays the current main lift height, in the selected units.
→ 55 55	Displays the current right boom heights, in the selected units, from left to right.
55 55 ←	Displays the current left boom heights, in the selected units, from left to right.

M 55 M	<p>SENSOR DISPLAY Menu</p> <p>↑</p> <p>SENSOR DISPLAY / SETUP (NO) Switch</p> <p>↓</p> <p>SETUP Menu</p>	<p>The Normal Operating Screen is usually displayed. If no switch is toggled for 30 seconds, the LCD will revert to this screen. Also, from any menu prompt, if you toggle and hold the "SETUP (NO)" switch for two seconds, the control panel will return to this screen. The heights are adjusted for the offset between the sensor and nozzles.</p>
---------------	---	--

Sensi 5	Displays the current control sensitivity (Sensi) setting. A higher number results in a quicker response. Range is from 1 to 10.
Soil ON	Use the " +/- " switch to set the sensor target to SOIL or CROP mode.
ReTune?	The ReTune will optimize your system for the best performance possible. This will take from one to three minutes. (<i>Section 6.2</i>)
More ?	Toggle the "AUTO (YES) " switch to edit or view more control settings.

Navigating past the end of the menu will return the control panel to the Normal Operating Screen

Table 14 – Full Menu Structure

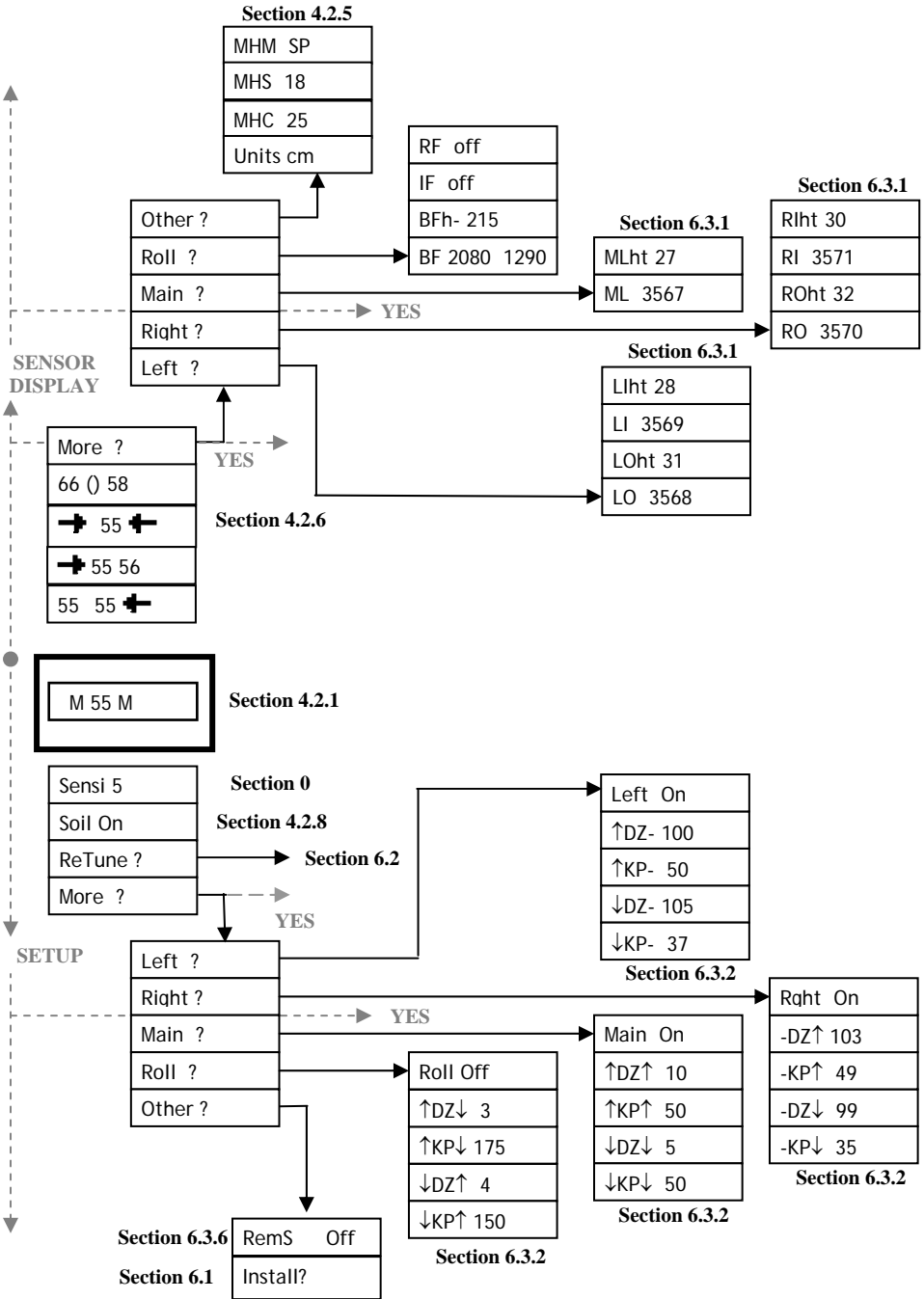

Canada

NORAC Systems International Inc.

CALL TOLL FREE: 1-800-667-3921
(306)664-6711

SHIPPING ADDRESS:
3702 Kinnear Place
Saskatoon, SK
S7P 0A6

United States

Norac, Inc.

CALL TOLL FREE: 1-866-306-6722
(763)786-3080

SHIPPING ADDRESS:
1290 Osborne Rd NE, Suite F
Fridley, MN
55432-2892